

SIDE ELEVATION DETAIL D HANDRAIL FRONT ELEVATION

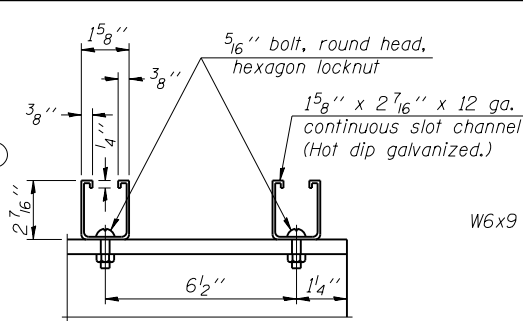

SECTION F-F LIGHTING FIXTURE MOUNTS (If required)

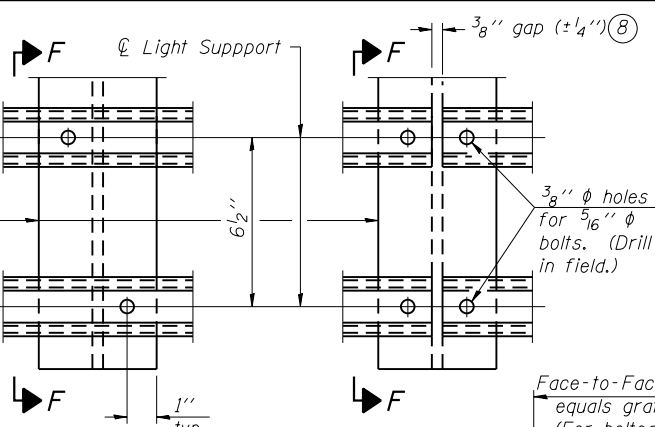

DETAIL F DETAIL G

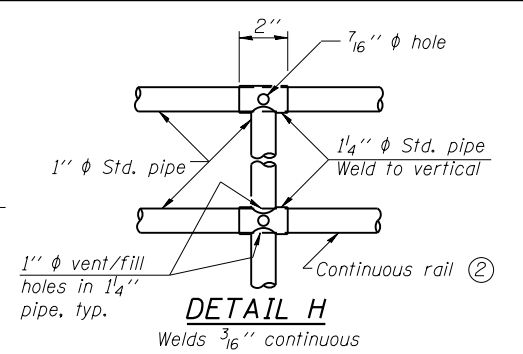

DETAIL H

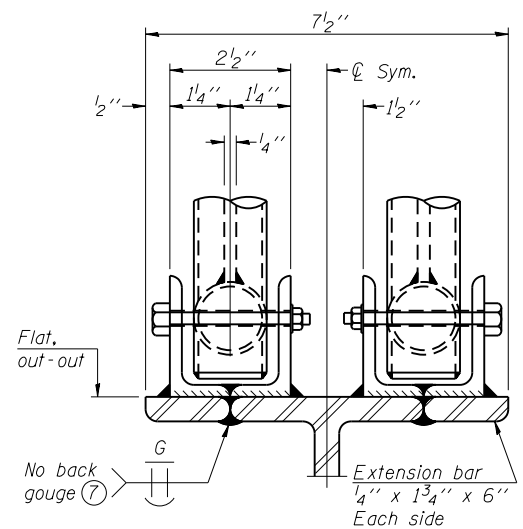

ELEVATION AT HANDRAIL JOINT

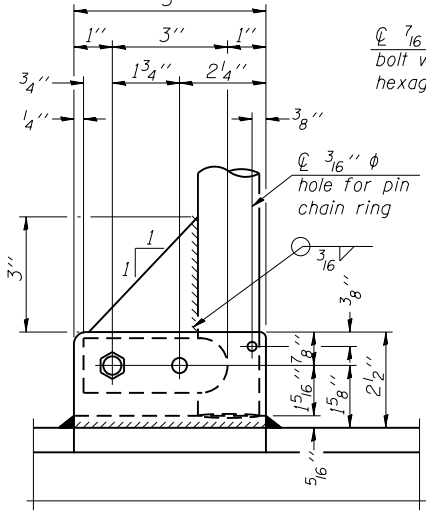

SIDE ELEVATION

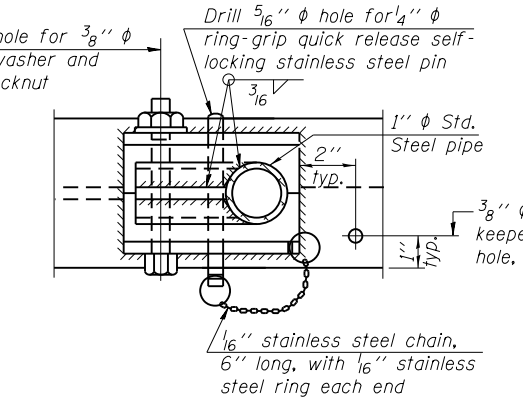

PLAN AT SINGLE HANDRAIL HINGE DETAIL E

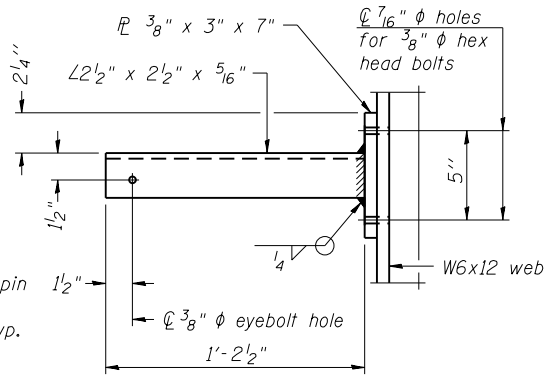

SECTION P-P

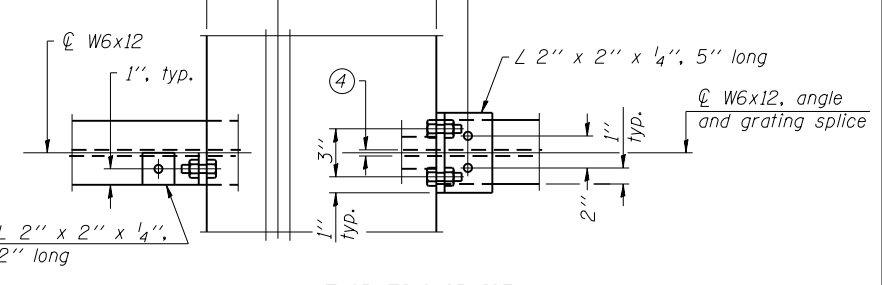

VIEW W-W

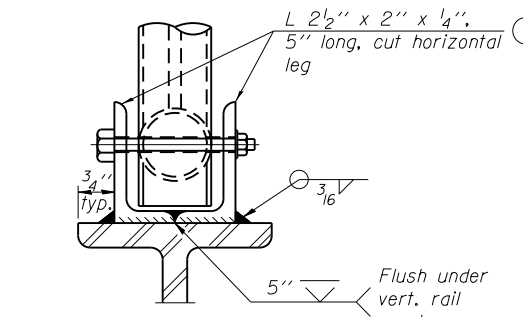

FRONT ELEVATION

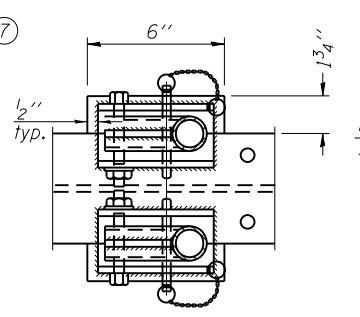

PLAN AT HANDRAIL JOINT

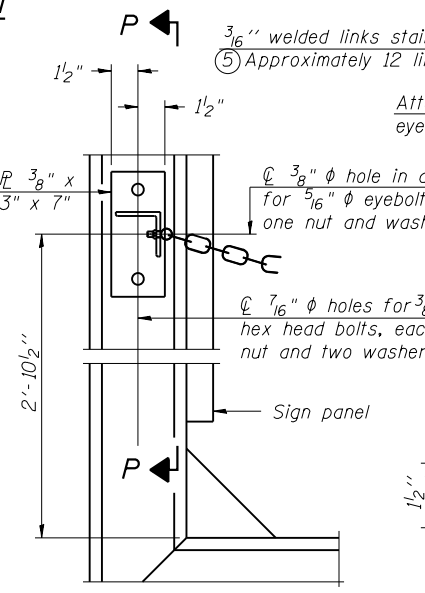

SAFETY CHAIN ATTACHMENT

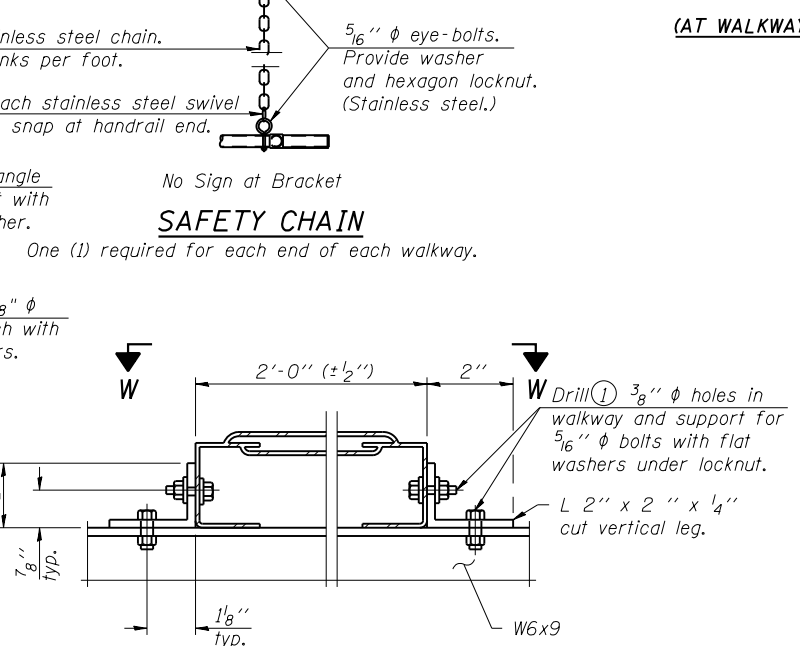

ALTERNATE FORMED PLANK GRATING DETAILS

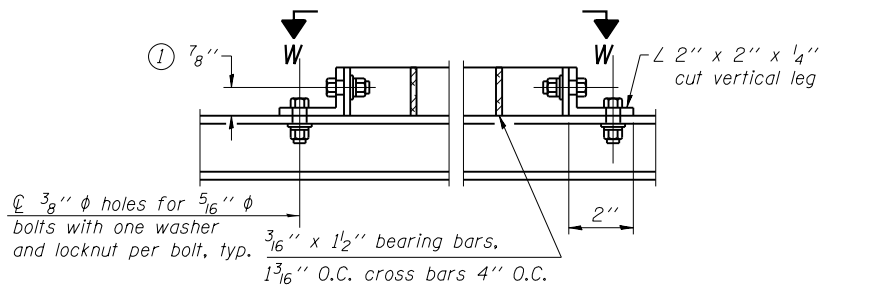

WELDED BAR GRATING DETAILS

- NOTES**
- Drilling holes in grating may be done in shop or field, based on Contractor's preference and subject to accurate alignment. Field drilled holes must be touched up with galvanized paint.
 - Horizontal rail member shall be continuous thru 1 1/4" std. pipe. Provide 7/16" hole in 1 1/4" std. pipe for 3/8" bolt. Field drill 7/16" hole in horizontal rail member. Provide washer and locknut for bolt. (Use 5/16" eyebolts in 7/16" holes on top rail at ends only.)
 - Install standard force-fit end caps or weld 1/8" end plates with 1/8" c.f.w. and grind smooth. (All rail ends.)
 - 3/8" (±1/4") gap between grating panels at splice.
 - Chain to be type 304L stainless steel suitable for prolonged exterior exposure. Approximately 3'-6" long chain per location. Maximum sag with handrail erected = 4".
 - 1/8" x 1/2" x 2" welded to handrail posts to protect locations that contact grating.
 - Extrusions may be used in lieu of details shown, with approval by Engineer.
 - Field cut ends of light support channels shall be free of burrs or hazardous projections and coated with zinc-rich primer or equivalent.

BM-4 6-1-12

MAURER-STUTZ ENGINEERS SURVEYORS

FILE NAME = D468683-sht-BM sign str.dgn	USER NAME = willis	DESIGNED -	REVISED -
		CHECKED -	REVISED -
		DRAWN -	REVISED -
		CHECKED -	REVISED -

STATE OF ILLINOIS DEPARTMENT OF TRANSPORTATION

BRIDGE MOUNT SIGN STRUCTURES WALKWAY DETAILS

SHEET NO. 4 OF 4 SHEETS

F.A.U. RTE. 6584	SECTION 105; (72-THB)BY	COUNTY PEORIA	TOTAL SHEETS 487	SHEET NO. 331
6585			CONTRACT NO. 68683	

ILLINOIS FED. AID PROJECT