

SECTION B-B

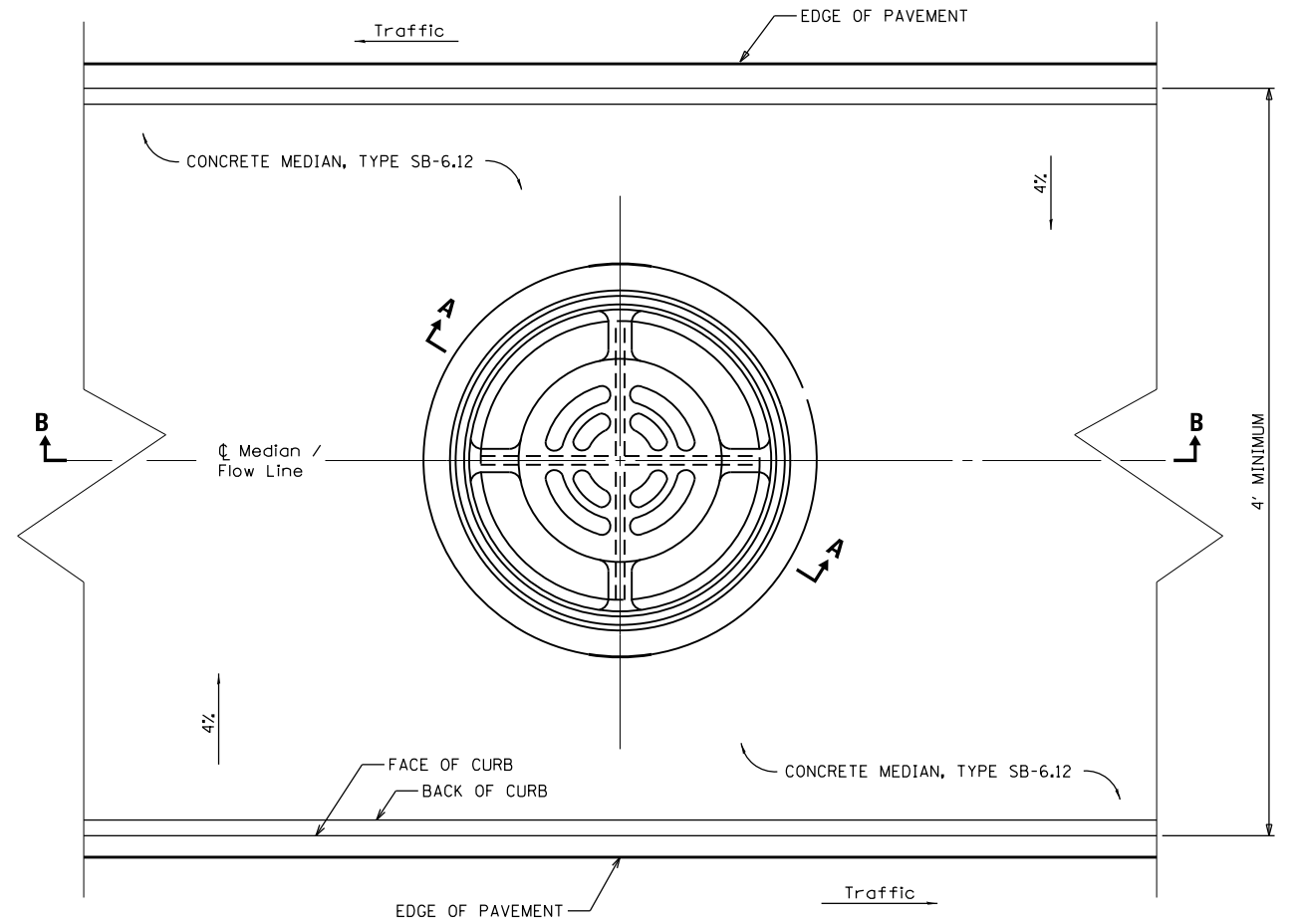

LOCATION SKETCH - PLAN

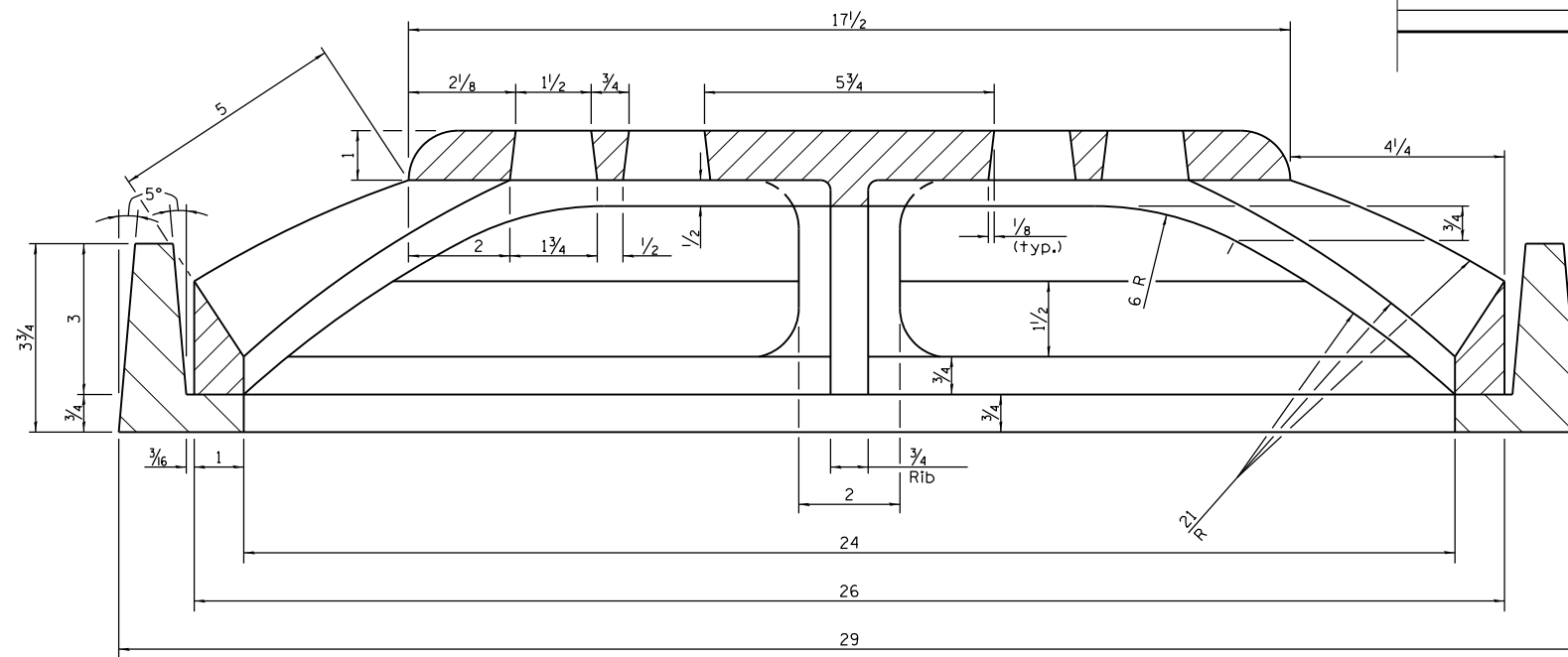

SECTION A-A

GENERAL NOTES

All slope ratios are expressed as units of vertical displacement to units of horizontal displacement (V:H).

All dimensions are in inches unless otherwise shown.

FILE NAME = S:\237\2013\23713009\00\A11enRdPh11\CADD	USER NAME = baswanson	DESIGNED -	REVISED -
CADD Sheets\0468683-sht-details-inlet ty	DRAWN -	REVISED -	
PLOT SCALE = 0:2.4000 '1' / in.	CHECKED -	REVISED -	
PLOT DATE = 1/24/2014 5:21:16 PM	DATE -	REVISED -	

F.A.U. RTE.	SECTION	COUNTY	TOTAL SHEETS	SHEET NO.
6584	105: (72-7HB)BY	PEORIA	487	381
6585	CONTRACT NO. 68683			