

SECTION A - A

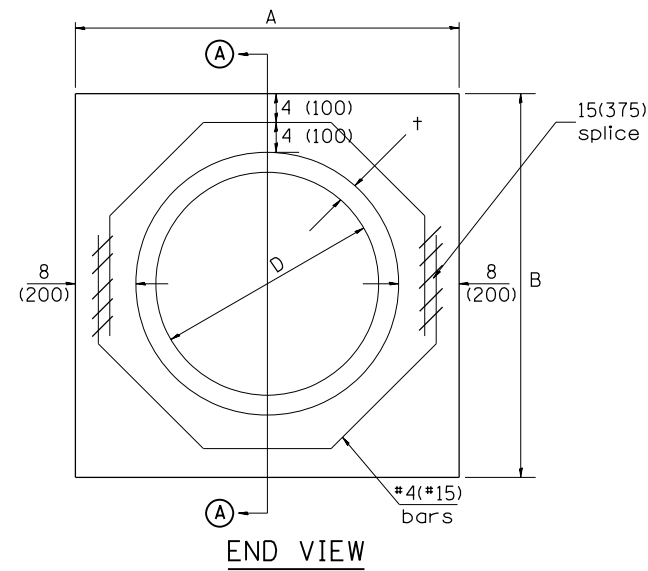

END VIEW

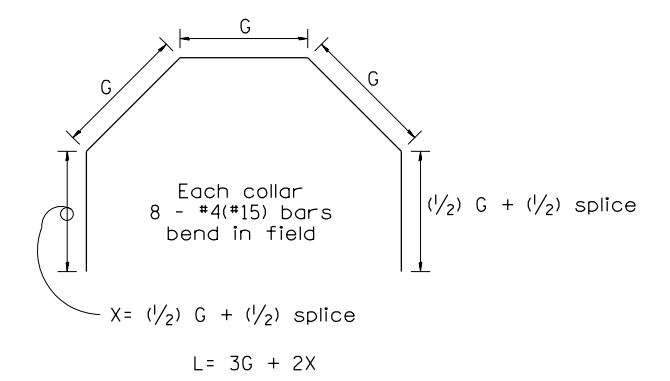

Each Collar									
					Reinforcement Bars				
D	t	A	B	CL. SI CONC.	G	X	L	Weight	
in (mm)	in (mm)	ft (m)	ft (m)	cu.yd. (m <sup>3</sup> )	in (mm)	in (mm)	ft (m)	lb (kg)	
12 (300)	2.00 (51)	2.67 (0.814)	2.67 (0.814)	0.4 (0.270)	9 <sup>15</sup> / <sub>16</sub> (253)	12 <sup>7</sup> / <sub>16</sub> (317)	4.57 (1.393)	24 (11)	
15 (375)	2.25 (57)	2.96 (0.902)	2.96 (0.902)	0.4 (0.315)	11 <sup>3</sup> / <sub>8</sub> (290)	13 <sup>3</sup> / <sub>16</sub> (335)	5.05 (1.541)	27 (12)	
18 (450)	2.50 (64)	3.25 (0.991)	3.25 (0.991)	0.5 (0.362)	12 <sup>13</sup> / <sub>16</sub> (327)	13 <sup>7</sup> / <sub>8</sub> (354)	5.54 (1.689)	30 (14)	
21 (525)	2.75 (70)	3.54 (1.079)	3.54 (1.079)	0.5 (0.411)	14 <sup>1</sup> / <sub>4</sub> (364)	14 <sup>5</sup> / <sub>8</sub> (372)	6.02 (1.836)	32 (15)	
24 (600)	3.00 (76)	3.83 (1.167)	3.84 (1.167)	0.6 (0.460)	15 <sup>11</sup> / <sub>16</sub> (401)	15 <sup>5</sup> / <sub>16</sub> (391)	6.51 (1.984)	35 (16)	
27 (675)	3.25 (83)	4.13 (1.259)	4.13 (1.259)	0.7 (0.516)	17 <sup>1</sup> / <sub>4</sub> (438)	16 <sup>1</sup> / <sub>16</sub> (409)	6.99 (2.131)	37 (17)	
30 (750)	3.50 (89)	4.42 (1.347)	4.42 (1.347)	0.7 (0.570)	18 <sup>11</sup> / <sub>16</sub> (475)	16 <sup>3</sup> / <sub>4</sub> (428)	7.48 (2.279)	40 (18)	
33 (825)	3.75 (95)	4.71 (1.436)	4.71 (1.436)	0.8 (0.624)	20 <sup>1</sup> / <sub>8</sub> (512)	17 <sup>1</sup> / <sub>2</sub> (446)	7.96 (2.426)	43 (19)	
36 (900)	4.00 (102)	5.00 (1.524)	5.00 (1.524)	0.9 (0.682)	21 <sup>9</sup> / <sub>16</sub> (549)	18 <sup>3</sup> / <sub>16</sub> (465)	8.44 (2.574)	45 (20)	
42 (1050)	4.50 (114)	5.58 (1.701)	5.58 (1.701)	1.0 (.800)	24 <sup>7</sup> / <sub>16</sub> (622)	19 <sup>3</sup> / <sub>4</sub> (501)	9.41 (2.869)	50 (23)	
48 (1200)	5.00 (127)	6.17 (1.881)	6.17 (1.881)	1.2 (0.930)	27 <sup>5</sup> / <sub>16</sub> (696)	21 <sup>3</sup> / <sub>16</sub> (538)	10.38 (3.164)	55 (25)	

GENERAL NOTES

1. THE COLLAR SHALL BE CONSTRUCTED ENTIRELY OF CLASS SI CONCRETE IN ACCORDANCE WITH THE APPLICABLE PORTIONS OF SECTION 503 OF THE STANDARD SPECIFICATIONS. REINFORCEMENT BARS SHALL CONFORM TO SECTION 508.
2. This work shall be paid for by the cubic yard (cubic meter) for CONCRETE COLLAR and by the pound (kg) for REINFORCEMENT BARS.

QUANTITIES	
CALC. BY: R. J. D.	2-2-98
CHECKED BY: R. D. H.	2-6-98
	DATE:

QUANTITY CALCULATIONS ARE ON FILE AT THE DISTRICT 4 OFFICE; BUREAU OF PROJECT IMPLEMENTATION; DOCUMENTATION SECTION

All dimensions are in inches (millimeters) unless otherwise noted.

01-01-97	RENUM. B-8.03, NEW REVISION BOX, REVISED	T.P.	09-01-00	CORRECT WEIGHT	J.A.	<b>STATE OF ILLINOIS DEPARTMENT OF TRANSPORTATION</b>	<b>PIPE CULVERT EXTENSION COLLAR (WITHOUT END SECTION)</b>	F.A. RTE.	SECTION	COUNTY	TOTAL SHEETS	SHEET NO.	
	TITLE BOX, ADDED QUANTITY CALCULATION BOX		10-16-06	REV. TO 2007 SPEC., CORRECT mm UNITS	M.A.						487	392	
04-01-97	CORRECT BAR	J.A.	2-15-11	ADDED GENERAL NOTE #2	R.D.			CONTRACT NO.					
02-10-98	REVISE QUANTITIES	J.A.						FED. ROAD DIST. NO. ILLINOIS FED. AID PROJECT					

NOT TO SCALE

CADD STD. 542016-D4