

PLAN

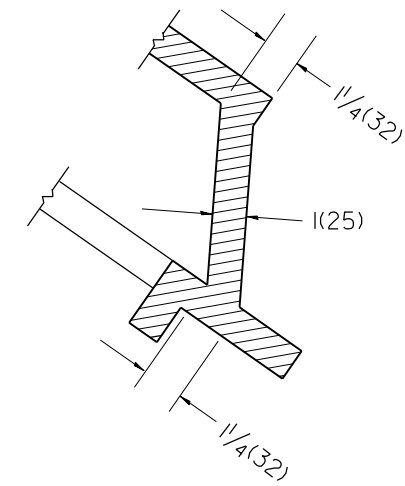

SECTION B - B

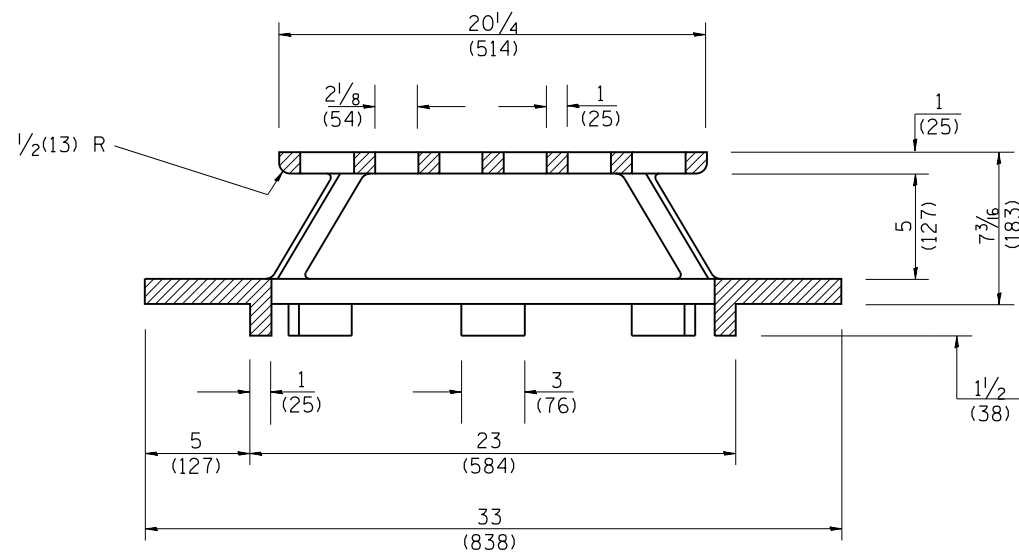

SECTION A - A

GENERAL NOTES

1. MATERIAL - Cast Gray Iron
Weight 209 lbs (95 kg)

All dimensions are in inches (millimeters) unless otherwise noted.

01-01-97	RENUM. B-10.02, NEW REVISION BOX	T.P.
10-16-06	REVISED TO 2007 SPEC.	M.A.

STATE OF ILLINOIS
DEPARTMENT OF TRANSPORTATION

TYPE 37 GRATE

NOT TO SCALE

CADD STD. 604301-D4

F.A. RTE.	SECTION	COUNTY	TOTAL SHEETS	SHEET NO.
			487	398
CONTRACT NO.				
FED. ROAD DIST. NO. ILLINOIS FED. AID PROJECT				