

LT & RT STA 662+87.44 TO 669+82.10  
 (SEE DETAIL C BELOW)

- ① EXIST. PCC PAVEMENT W/OVERLAY
- ② EXIST. HMA SHOULDERS
- ③ EXIST. AGGREGATE SHOULDERS
- ④ PROP. HMA SURFACE REMOVAL 3/4"
- ⑤ PROP. POLY. HMA SURFACE CSE. MIX "D" N50 2"
- ⑥ PROP. HMA SURFACE CSE. MIX "C" N50 2"
- ⑦ PROP. AGGREGATE WEDGE SHOULDERS, TYPE B
- ⑧ PROP. HMA SURFACE REMOVAL (VARIABLE DEPTH)

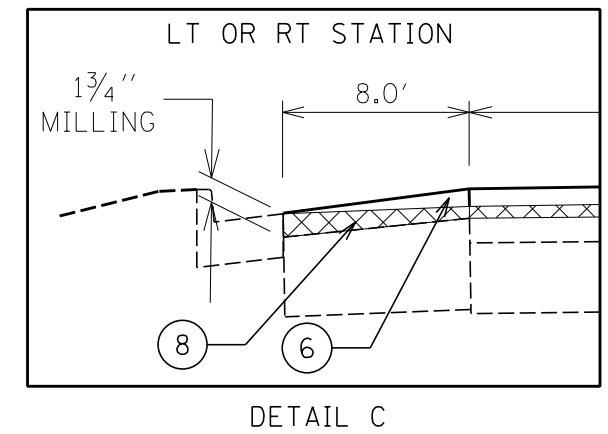

FILE NAME =	USER NAME = mendezpj	DESIGNED -	REVISED -
S:\GEN\DRAW\STD&PLNS\SQUAD11\68980\468980 Plans.dgn		DRAWN -	REVISED -
Default	PLOT SCALE = 40.0000' / in.	CHECKED -	REVISED -
	PLOT DATE = 1/30/2014	DATE -	REVISED -

STATE OF ILLINOIS  
 DEPARTMENT OF TRANSPORTATION

TYPICAL SECTIONS

SCALE: SHEET 6 OF 6 SHEETS STA. TO STA.

F.A.P. RTE.	SECTION	COUNTY	TOTAL SHEETS	SHEET NO.
310	(104,105)RS-4	MERCER	32	12
CONTRACT NO. 68980				
ILLINOIS FED. AID PROJECT				