

CROSS SECTION
(Looking East)

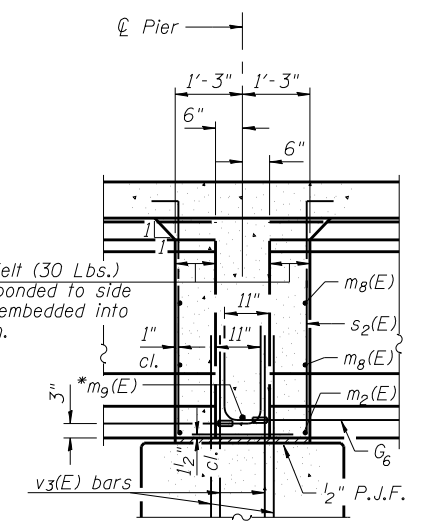

SECTION B-B

Dimensions along ϕ of beam, except as shown.

*Tightly fasten the #8 bars together with No. 9 wire ties.

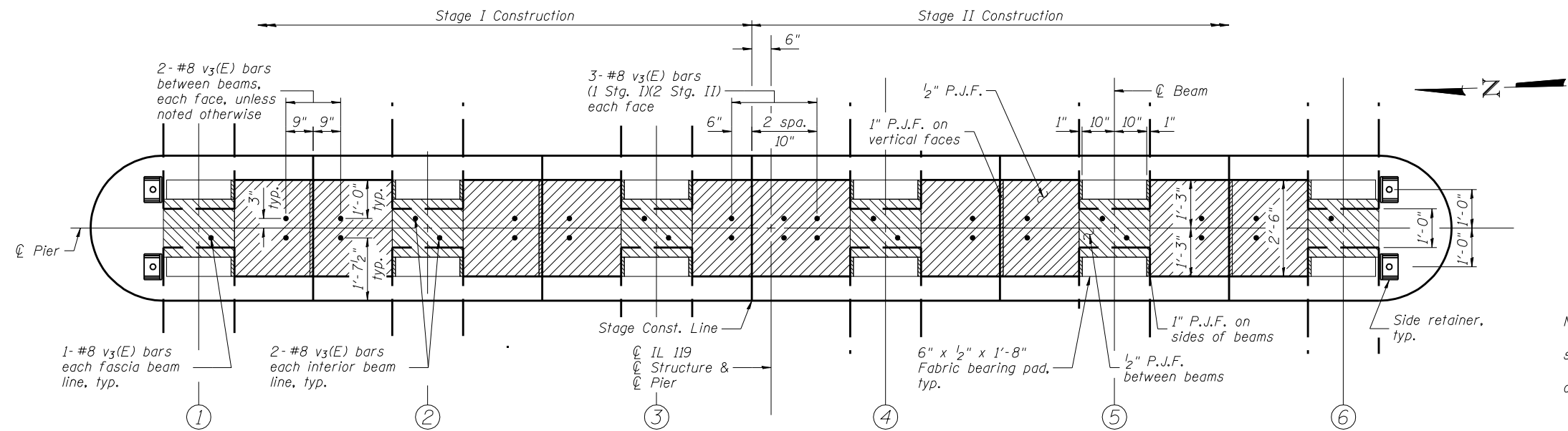

PLAN AT PIER
(Showing bearing and P.J.F. details)

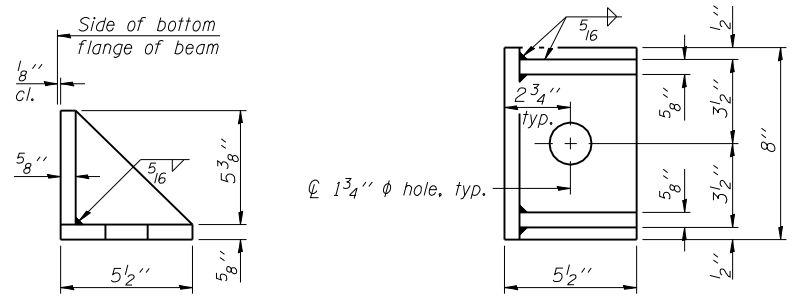

SIDE RETAINER
(2 required each side of pier).
Equivalent rolled angle with stiffeners will be allowed in lieu of welded plates.

Notes:
Reinforcement bars in diaphragm are billed with superstructure on sheet 13 of 33.
Concrete in diaphragm is included with Concrete Superstructure on sheet 13 of 33.
For details of $s_2(E)$ bar see sheet 13 of 33.
See sheet 10 of 33 for location of Section B-B.
Cost of 30 Lb. roofing felt is included with Concrete Superstructure.
The side retainer shall be galvanized after shop fabrication according to AASHTO M 111.
Anchor bolt assemblies shall be galvanized according to Article 1006.09 of the Standard Specifications.
Anchor bolts shall be ASTM F1554 all-thread (or an Engineer-approved alternate material) of the grade(s) and diameter(s) specified. The corresponding specified grade of AASHTO M314 anchor bolts may be used in lieu of ASTM F1554.
Anchor bolts for side retainers may be either cast in place or installed in holes drilled after the supporting member is in place and prior to pouring the deck.
Drilled and set anchor bolts shall be installed according to Article 521.06 of the Standard Specifications.
Cost of side retainer and anchor bolts shall be included with Concrete Structures.
For details of bar $v_3(E)$, see sheets 26, 27 and 28 of 33.

PRINT DATE: 3/24/2014 12:45:13 PM Z:\10053301\1119_ever_Vermilion\pdr\Bridges\Final\Plotsheets\09220207-70614-015-Pier-Diag.dgn

EFK Moen, LLC
Civil Engineering Design
331 Salem Place, Suite 225
Fairview Heights, IL 62208
Phone 618-206-4250

USER NAME = cdl	DESIGNED - CTW	REVISED -
PLOT SCALE = 0.25' = 1" IN.	CHECKED - CDL	REVISED -
PLOT DATE = 3/24/2014	DRAWN - CTW	REVISED -
	DATE - 3/24/2014	REVISED -

STATE OF ILLINOIS
DEPARTMENT OF TRANSPORTATION

PIER DIAPHRAGM DETAILS
STRUCTURE NO. 092-0207

SHEET NO. 15 OF 33 SHEETS

F.A.P. RTE.	SECTION	COUNTY	TOTAL SHEETS	SHEET NO.
711	116BR-1	VERMILION	84	45
CONTRACT NO. 70614				
ILLINOIS FED. AID PROJECT				