

Camera Lowering Device for Pole Mounting Multi-Function Surveillance Cameras CLDMG2-HYP-045-ST-D

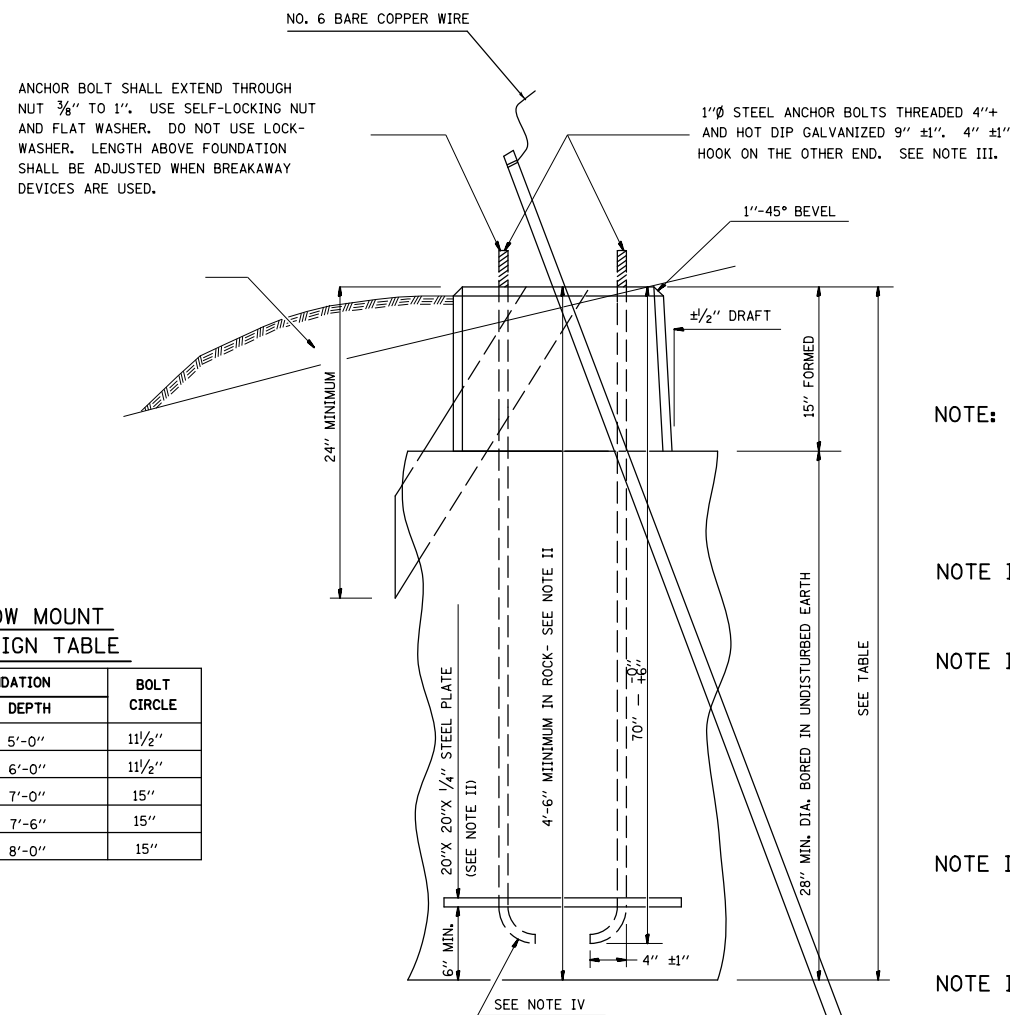

LOW MOUNT DESIGN TABLE

MOUNTING FOUNDATION HEIGHT	DEPTH	BOLT CIRCLE
30' OR LESS	5'-0"	11 1/2"
31'-35'	6'-0"	11 1/2"
36'-40'	7'-0"	15"
41'-45'	7'-6"	15"
46'-50'	8'-0"	15"

FOUNDATION DETAIL LOCATION 557004.8A.09C

NOTE:

AFTER POURING CONCRETE, THE FORM SHALL REMAIN UNDISTURBED OVERNIGHT.

THE TOP 15" ONLY SHALL BE FORMED. CONCRETE BOUNDED BY UNDISTURBED EARTH ONLY SHALL FILL THE REMAINDER OF THE HOLE.

NOTE I:

MINIMUM CLEARANCE FROM THE OUTSIDE EDGE OF FOUNDATION TO ANY PART OF THE POLE BASEPLATE SHALL BE 2".

NOTE II:

THE DEPTH OF THE FOUNDATION MAY BE REDUCED 6" FOR EVERY FOOT OF ROCK ENCOUNTERED WITH A MINIMUM DEPTH OF 4'-6". WHEN THE DEPTH OF THE FOUNDATION IS DECREASED TO LESS THAN 6'-0", THE ANCHOR BOLTS SHALL BE CUT, THREADED, AND A STEEL PLATE 20" X 20" X 1/4" SHALL BE INSTALLED ON THE ANCHOR BOLTS 6" ABOVE THE BOTTOM OF THE EXCAVATION. THE COST SHALL BE INCIDENTAL TO THE FOUNDATION.

NOTE III:

ON PARAPET WALLS USE 1/4" ANCHOR BOLTS. USE SELF-LOCKING NUT AND FLAT WASHER. DO NOT USE LOCKWASHER. (FOR DETAILS SEE STANDARD III/2.35 OF BRIDGE DESIGN MANUAL.

NOTE IV:

BEND RADIUS SHALL BE FOUR TIMES BOLT DIAMETER.

NOTE V:

CONNECT GROUND WIRES TO POLE BASE GROUND LUG, NOT ANCHOR BOLTS OR TRANSFORMER BASE.

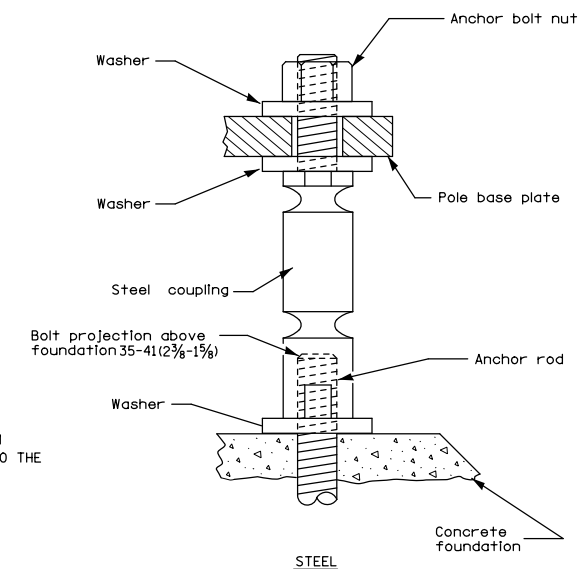

Installation Instructions:

Screw couplings onto anchor bolts to end of threads. Very important to level couplings to avoid over stressing and either cracking or stripping of the threads within the coupling.

DETAIL A

TYPICAL COUPLING FOR CONCRETE FOUNDATION

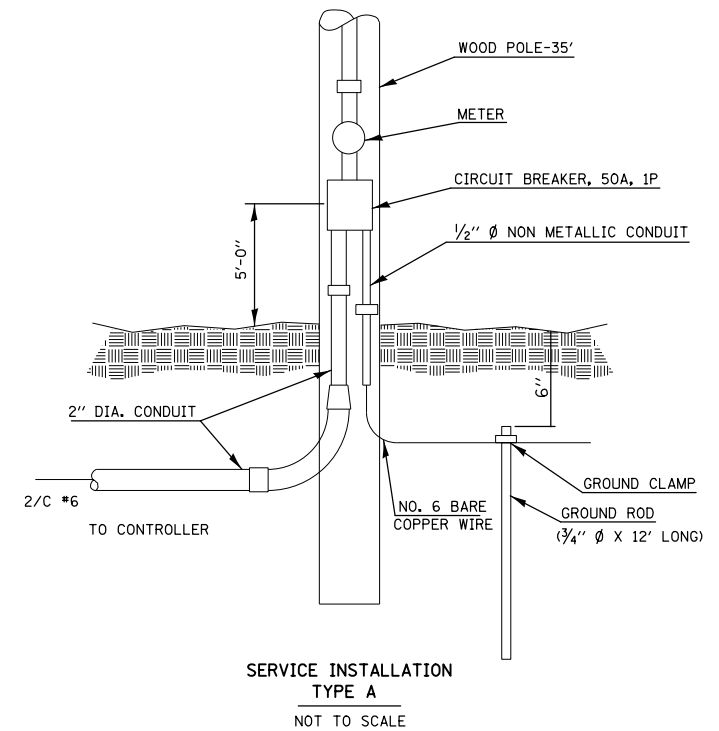

SERVICE INSTALLATION TYPE A NOT TO SCALE

FILE NAME =	USER NAME = biggsrd	DESIGNED -	REVISED -
ei:\pw_work\pwidot\biggsrd\d0340463\PTZ	camera plans.dgn	DRAWN -	REVISED -
	PLOT SCALE = 40.0000' / in.	CHECKED -	REVISED -
\$MODELNAME\$	PLOT DATE = 2/7/2014	DATE -	REVISED -

STATE OF ILLINOIS DEPARTMENT OF TRANSPORTATION

SERVICE INSTALLATION AND POLE MOUNTED CCTV DETAIL WITH CAMERA LOWERING DEVICE

SCALE: SHEET 1 OF 3 SHEETS STA. TO STA.

F.A.P. RTE.	SECTION	COUNTY	TOTAL SHEETS	SHEET NO.
VAR.	FY2014 ITS-1	CHAMPAIGN	74	72
			CONTRACT NO. 70A26	
ILLINOIS FED. AID PROJECT				