

IF CROSSWALK IS NOT PRESENT,
LOCATE STOP LINE AT DESIRED
STOPPING POINT.

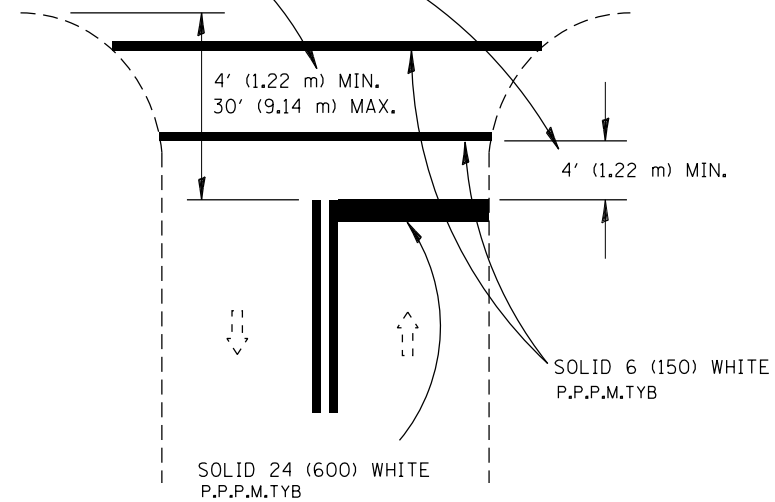

RURAL

RELEASE NO PASSING ZONE
100 FT AFTER STOP BAR
WHERE APPROPRIATE

500' FT PASSING
ZONE APPROACHING STOP BAR

STOP LINES

All dimensions are in inches
(millimeters) unless otherwise noted.

ILLINOIS DEPARTMENT OF TRANSPORTATION
DISTRICT 6 PAVEMENT MARKING STANDARDS
DATE 2013-01 NOT TO SCALE

D6PAVMRK.DGN
•DGN-ONLY•

FILE NAME =	USER NAME = sparksgw	DESIGNED -	REVISED -
ct:\pw\work\p\idot\sparksgw\0373645\0672890-sht-district.details.dgn		DRAWN -	REVISED -
	PLOT SCALE = 100.0000' / in.	CHECKED -	REVISED -
D6PaveMark	PLOT DATE = Feb-04-2014 01:49:47PM	DATE -	REVISED -

**STATE OF ILLINOIS
DEPARTMENT OF TRANSPORTATION**

DISTRICT 6 PAVEMENT MARKING DETAILS

SCALE: SHEET 6 OF 17 SHEETS STA. TO STA.

F.A.U. RTE.	SECTION	COUNTY	TOTAL SHEETS	SHEET NO.
8012	21(W-3, TS-1, RS-7)	SANGAMON	679	458
CONTRACT NO. 72890			ILLINOIS FED. AID PROJECT	