

PROPOSED TYPICAL SECTION
STATION 491+00.15 TO STATION 494+01.78
 (ALL SLOPES AND DIMENSIONS AT RIGHT ANGLES TO BASELINE)

PAVED SHOULDER REMOVAL

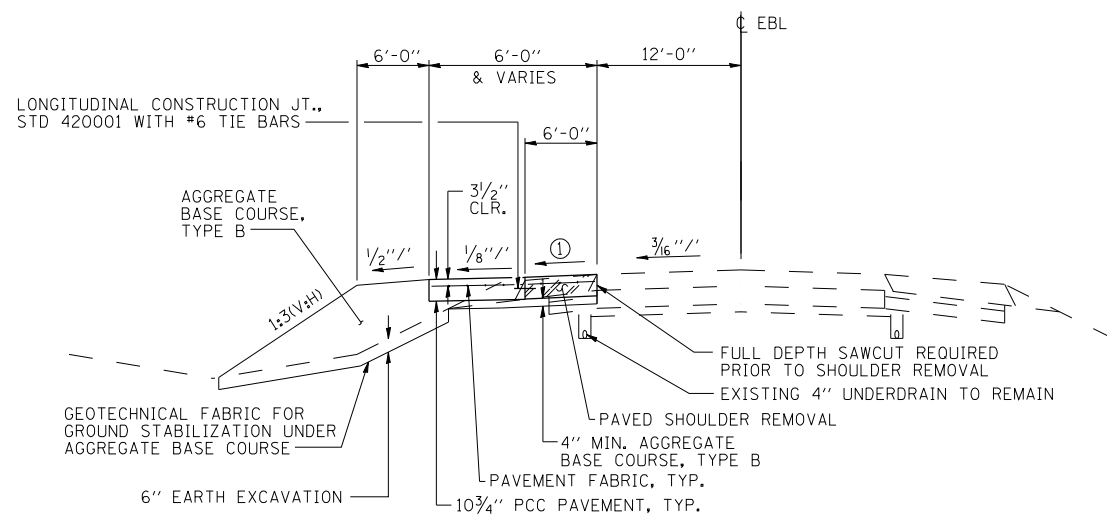

PROPOSED TYPICAL SECTION
STATION 487+00.00 TO STATION 491+00.15

① 1/4" SLOPE; TRANSITION FROM 1/4" TO EXISTING SHOULDER SLOPE WITHIN 10 FEET

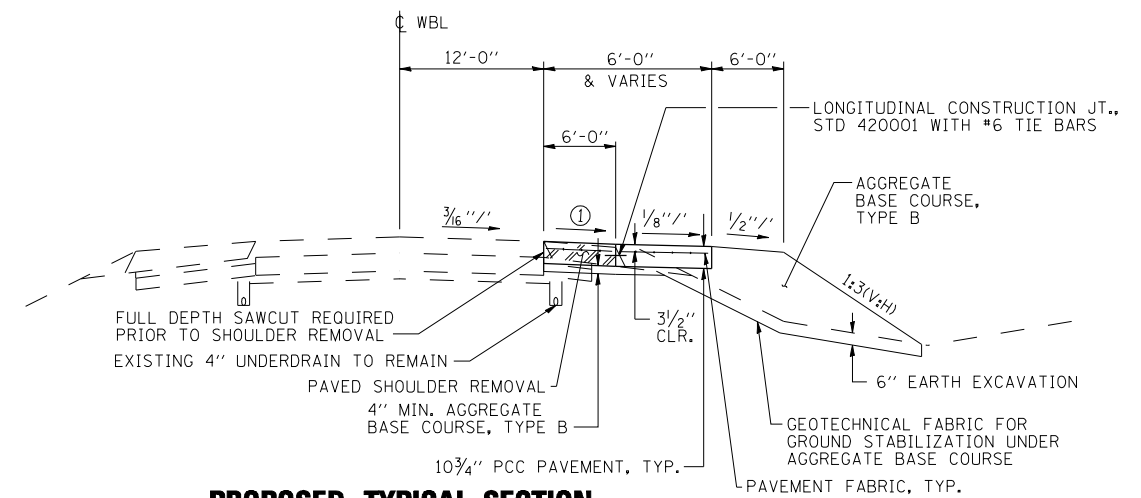

PROPOSED TYPICAL SECTION
STATION 494+01.78 TO STATION 498+00.00

PRINT DRIVER = L:\00-EB\0175
 SCALE NAME = 1:1000
 FILE NAME = 175-113-18-18.dwg



USER NAME = has	DESIGNED - ELH	REVISED -
ESCA PROJECT NO. 1000.05	DRAWN - HAS	REVISED -
PLOT SCALE = 0.2" = 1' / IN.	CHECKED - RDP	REVISED -
PLOT DATE = 1/29/2014 1:35:23 PM	DATE - 08/13	REVISED -

STATE OF ILLINOIS
DEPARTMENT OF TRANSPORTATION

WEST MEDIAN CROSSOVER - EB
PROPOSED TYPICAL SECTIONS

SCALE: NONE SHEET NO. 1 OF 1 SHEETS STA. TO STA.

F.A.I. RTE.	SECTION	COUNTY	TOTAL SHEETS	SHEET NO.
70	(26-3B-1, 3B-1(3))BR	FAYETTE	277	18
FED. ROAD DIST. NO. ILLINOIS FED. AID PROJECT			CONTRACT NO. 74175	