

PLAN SHOWING OUTLINES

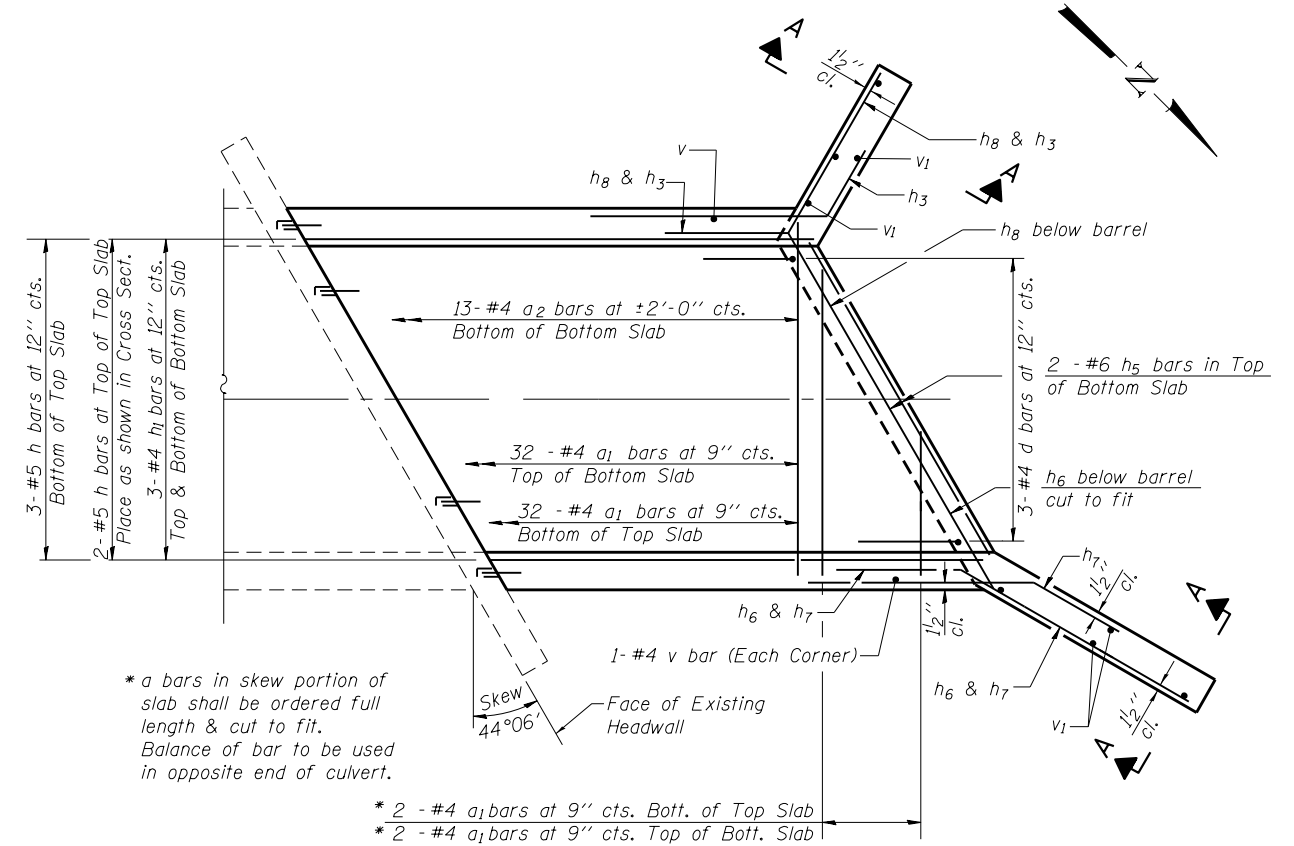

PLAN SHOWING REINFORCEMENT

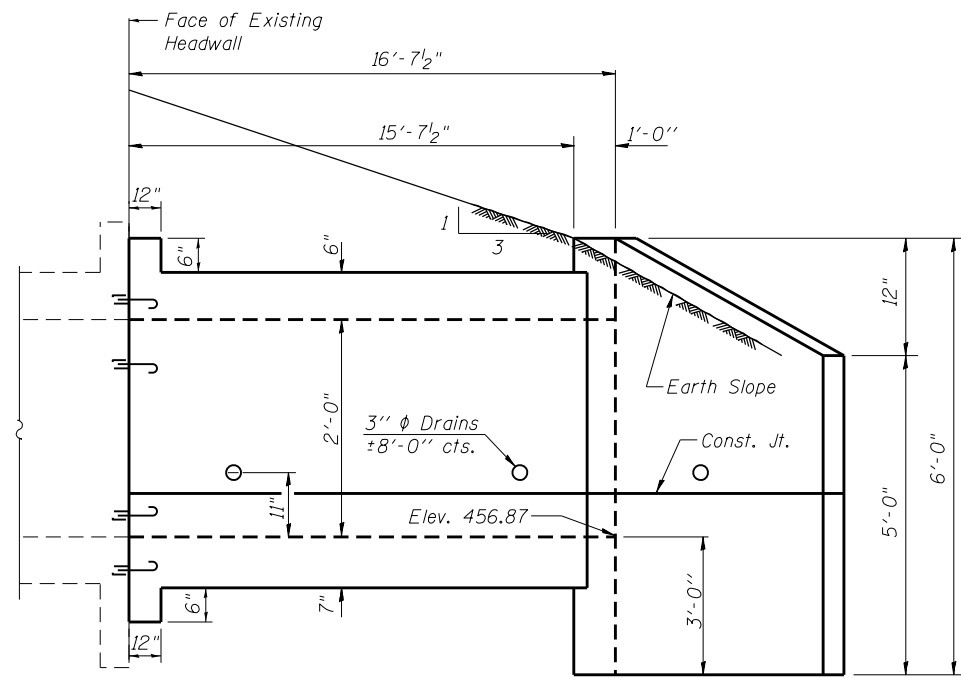

ELEVATION  
Dimensions at Rt. L's to  $\varnothing$  Roadway

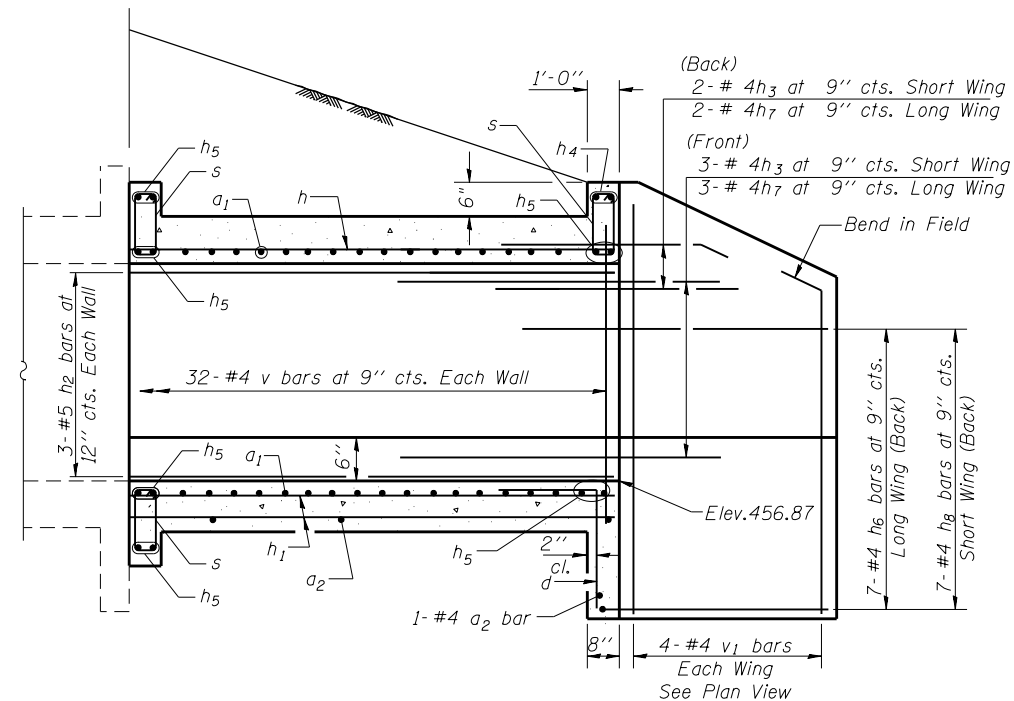

LONGITUDINAL SECTION  
Dimensions at Rt. L's to  $\varnothing$  Roadway

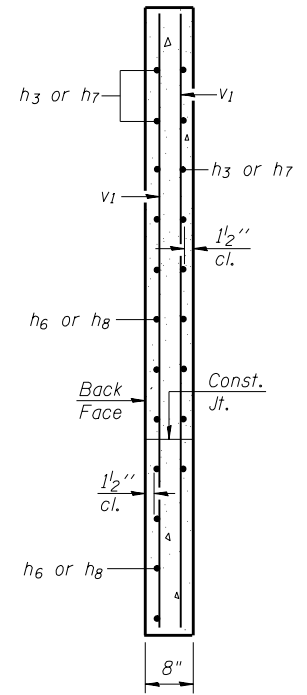

SECTION A-A

SSB-H-L

7-1-10



USER NAME =	DESIGNED -	REVISED -
	CHECKED -	REVISED -
PLOT SCALE =	DRAWN -	REVISED -
PLOT DATE =	CHECKED -	REVISED -

STATE OF ILLINOIS  
DEPARTMENT OF TRANSPORTATION

PROPOSED CULVERT EXTENSION DETAILS

SHEET NO. OF SHEETS

F.A.P. RTE.	SECTION	COUNTY	TOTAL SHEETS	SHEET NO.
134	(110, 111)-I	MADISON	34	26
CONTRACT NO. 76F76				

ILLINOIS FED. AID PROJECT

X:\CH\NE\2011\11004-14\CAD\Plans\AS SUBMITTED TO DB\Details-1.dgn