

NOTES

1. PAINT CURB AND NOSE SOLID FOR 10 FEET OR RADIUS OF NOSE, WHICHEVER IS GREATER.
2. PAINT MINIMUM OF 3 STRIPES IN DIRECTION OF TRAFFIC.
3. REDUCED SPACING USED TO OBTAIN 3 STRIPS MINIMUM.
4. STRIPING RECOMMENDED ONLY WHERE OPERATIONAL PROBLEMS DICTATE.
5. PAINT SOLID WHERE A MINIMUM OF 3 STRIPES CANNOT BE PLACED.

SPACING

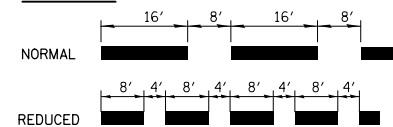

CURB MARKING DETAIL

MARKER ORIENTATION WITHIN LIMITS SHOWN

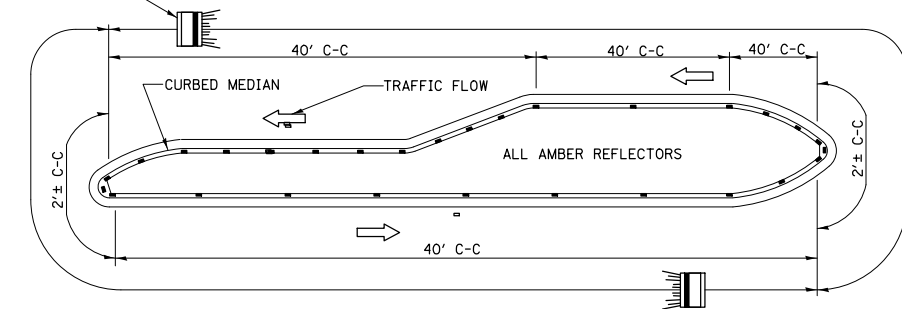

NOTES

1. PRISMATIC REFLECTORS SHALL BE MONO-DIRECTIONAL AND POSITIONED SO THAT THE REFLECTIVE FACE IS FACING THE APPROACHING TRAFFIC.
2. PRISMATIC REFLECTORS SHALL BE SECURED IN PLACE WITH AN EPOXY ADHESIVE.
3. PRISMATIC REFLECTORS SHALL BE EITHER AMBER OR CRYSTAL IN COLOR.
4. THERE SHALL BE MINIMUM OF 3 REFLECTORS ALONG EACH SIDE OF ISLANDS.
5. REFLECTORS SHALL BE PLACED ON THE TOP OF CURB IF POSSIBLE.

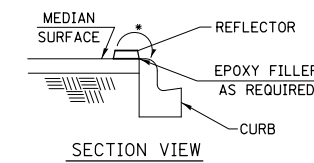

• IF POSSIBLE, PLACE REFLECTOR ON CURB TOP.

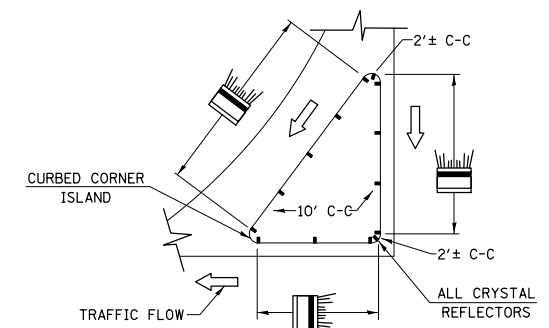

TYPICAL PLACEMENT OF PRISMATIC REFLECTORS ON CURBS
(NO SCALE)

FILE NAME =	USER NAME = mlcsmr	DESIGNED -	REVISED -
et:\pw\work\p\dot\mlcsmr\d0345201\d876	61-sht-pln.dgn	DRAWN -	REVISED -
	PLOT SCALE = 100.0000' / in.	CHECKED -	REVISED -
	PLOT DATE = 2/6/2014	DATE -	REVISED -

**STATE OF ILLINOIS
DEPARTMENT OF TRANSPORTATION**

PAVEMENT MARKING DETAILS FOR CURBS

SCALE: SHEET NO. OF SHEETS STA. TO STA.

F.A. RTE.	SECTION	COUNTY	TOTAL SHEETS	SHEET NO.
•	(109,110)RS-1, 31-2RS	WASHINGTON	40	40
•FAP 690/FAS 819/FAP 322		CONTRACT NO. 76G61		
FED. ROAD DIST. NO.		ILLINOIS FED. AID PROJECT		