

**PLUG DRAIN DETAIL**

See sheet 14 & 15 of 22 for locations

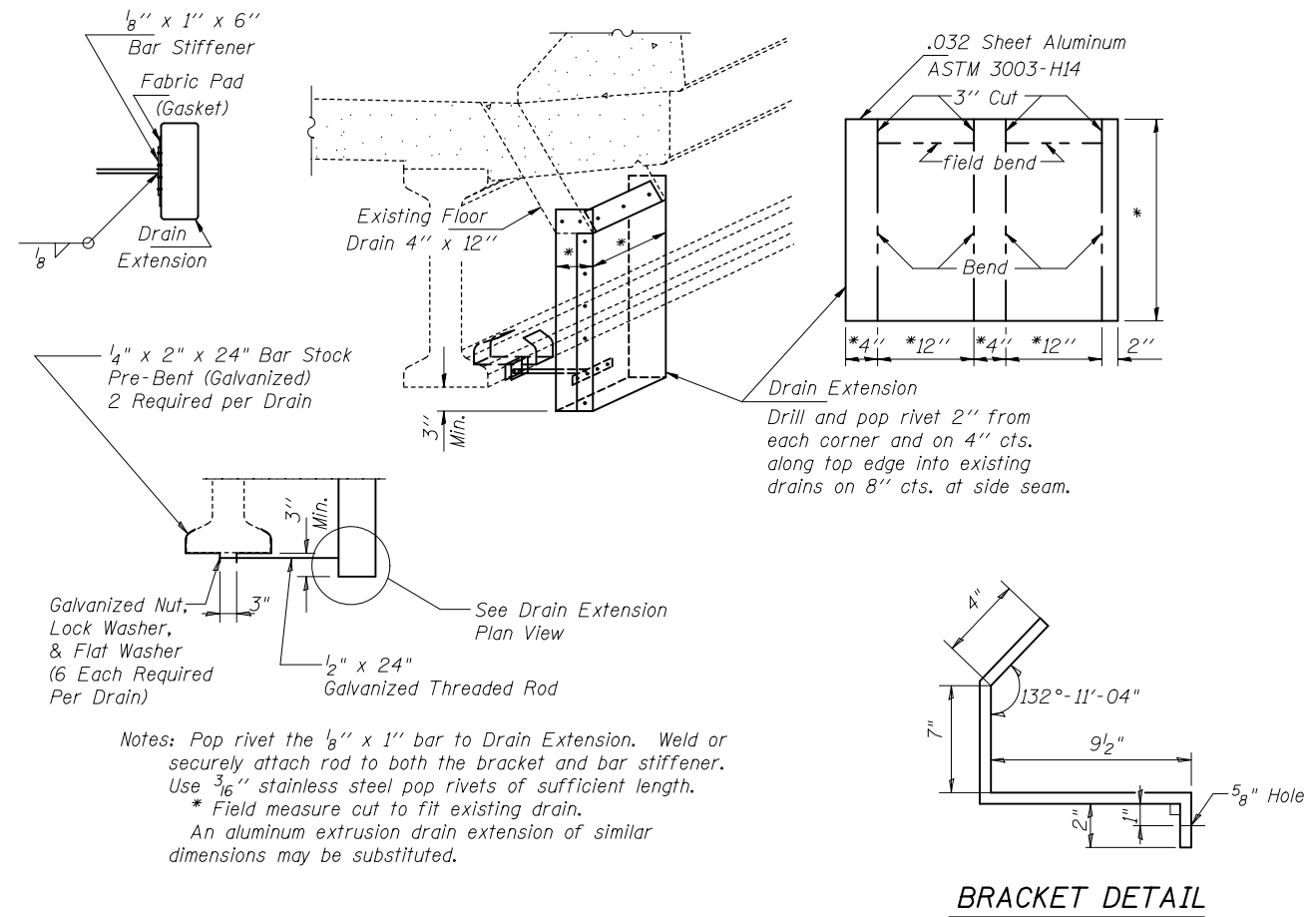

**FLOOR DRAIN EXTENSION DETAIL**

See sheet 14 & 15 of 22 for locations

DESIGNED - A.Y.V.	EXAMINED	DATE -	<b>STATE OF ILLINOIS DEPARTMENT OF TRANSPORTATION</b>	<b>DRAIN DETAILS SN 014-0058</b>	F.A.P. RTE.	SECTION	COUNTY	TOTAL SHEETS	SHEET NO.	
CHECKED -	ENGINEER OF STRUCTURAL SERVICES				327	14-14B-I	CLINTON	27	21	
DRAWN - A.Y.V.	PASSED	REVISED			CONTRACT NO. 76G91					
CHECKED -	ENGINEER OF BRIDGES AND STRUCTURES	REVISED			ILLINOIS FED. AID PROJECT					
					SHEET NO. 16 OF 22 SHEETS					