

When cantilever forming brackets are used, the work shall be done according to Article 503.06(b) of the Standard Specifications, except as modified below and in the details shown on this sheet.

The finishing machine rails shall be placed on the top flange of the exterior beams.

The beams or girders, supporting cantilever forming brackets, shall be tied together at 4 foot intervals.

For Standard construction, or Stage Construction the Hardwood bracing materials shall be placed as shown between webs of beams in each bay.

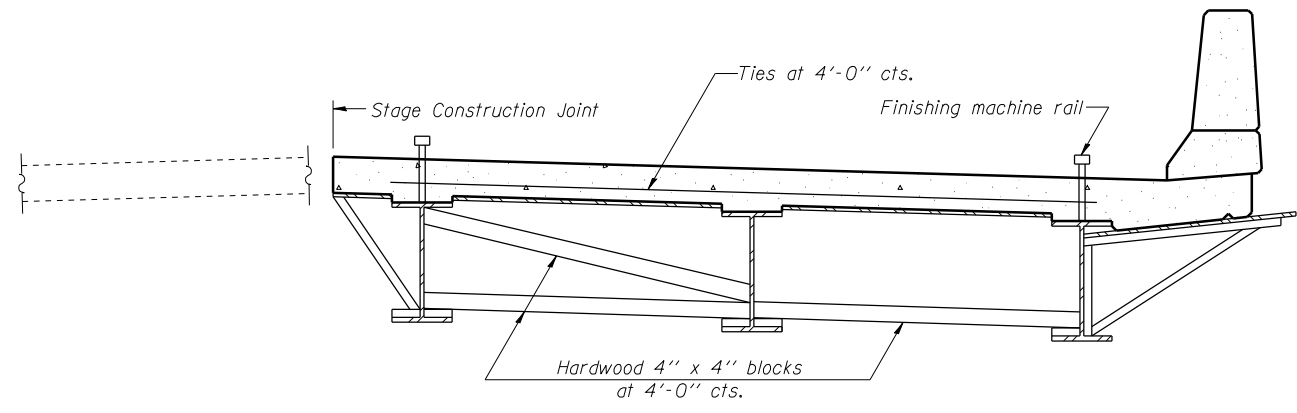

**FORM BRACES FOR
STAGE CONSTRUCTION**

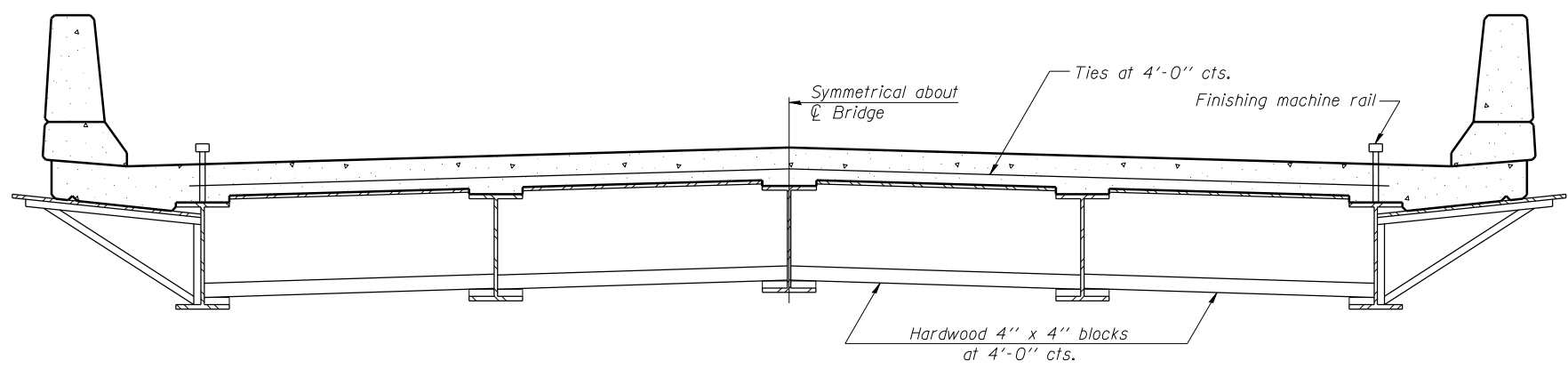

**FORM BRACES FOR
STANDARD CONSTRUCTION**

PRINT DRIVER = L:\035\03\1035\03\1035.dwg
 USER NAME = KAH
 PLOT DATE = 1/22/2014 5:24:27 PM
 PLOT SCALE = 0.25" = 1'-0"

SB-1

7-1-10



USER NAME = kah	DESIGNED - SHL	07/13	REVISED -
ESCA PROJECT NO. 1035.03	CHECKED - RDP	09/13	REVISED -
PLOT SCALE = 0.25" = 1'-0" IN.	DRAWN - KAH	07/13	REVISED -
PLOT DATE = 1/22/2014 5:24:27 PM	CHECKED - SHL	08/13	REVISED -

**STATE OF ILLINOIS
DEPARTMENT OF TRANSPORTATION**

**CANTILEVER FORMING BRACKETS FOR SUPERSTRUCTURES WITH
W27 BEAMS AND SMALLER
STRUCTURE NO. 035-0017**

SHEET NO. 25 OF 29 SHEETS

F.A.P. RTE.	SECTION	COUNTY	TOTAL SHEETS	SHEET NO.
782	115B-1	HARDIN	70	48
ILLINOIS FED. AID PROJECT			CONTRACT NO. 78263	