

INDEX OF SHEETS

SHEET NO.	DESCRIPTION
1	TITLE SHEET & SUMMARY OF QUANTITIES
2	PLAN & PROFILE, TYPICAL SECTIONS, GENERAL NOTES & FIELD ENTRANCE DETAILS
3	SIDEROAD PLAN & PROFILE, STONE RIPRAP DITCH DESIGN
4-6	ROADWAY CROSS SECTIONS
7-15	BRIDGE DESIGN

000001-06	STANDARD SYMBOLS, ABBREVIATIONS & PATTERNS
280001-07	TEMPORARY EROSION CONTROL SYSTEMS
515001-03	NAME PLATE FOR BRIDGES
701901-03	TRAFFIC CONTROL DEVICES
B.L.R. 21-9	TYPICAL APPLICATION OF TRAFFIC CONTROL DEVICES FOR CONSTRUCTION ON RURAL LOCAL HIGHWAYS
B.L.R. 22-7	TYPICAL APPLICATION OF TRAFFIC CONTROL DEVICES FOR CONSTRUCTION ON RURAL LOCAL HIGHWAYS (TWO-LANE TWO-WAY RURAL TRAFFIC) (ROAD CLOSED TO THRU TRAFFIC)

SUMMARY OF QUANTITIES

CODE NO.	ITEM	UNIT	QUANTITY
20200100	EARTH EXCAVATION	CU YD	152.00
20300100	CHANNEL EXCAVATION	CU YD	140.00
20400800	FURNISHED EXCAVATION	CU YD	476.00
28000305	TEMPORARY DITCH CHECKS	FOOT	14.00
28100807	STONE DUMPED RIPRAP, CLASS A4	TON	250.00
40200800	AGGREGATE SURFACE COURSE, TYPE B	TON	775.00
50100100	REMOVAL OF EXISTING STRUCTURES	EACH	1.00
50300225	CONCRETE STRUCTURES	CU YD	21.60
50300280	CONCRETE ENCASEMENT	CU YD	2.80
50400305	PRECAST PRESTRESSED CONCRETE DECK BEAMS (17" DEPTH)	SQ FT	1080.00
50800105	REINFORCEMENT BARS	POUND	2400.00
Δ 50900205	STEEL RAILING, TYPE S1	FOOT	88.00
51201400	FURNISHING STEEL PILES 10X42	FOOT	525.00
51202305	DRIVING PILES	FOOT	525.00
51203400	TEST PILE STEEL HP 10X42	EACH	1.00
51500100	NAME PLATES	EACH	1.00
542A5509	PIPE CULVERTS, CLASS A, TYPE 1 EQUIVALENT ROUND-SIZE 54"	FOOT	48.00
67100100	MOBILIZATION	L SUM	1.00
Δ 78201000	TERMINAL MARKER - DIRECT APPLIED	EACH	4.00
X25010000	SEEDING, CLASS 2 (SPECIAL)	ACRE	0.50
Z0068900	STONE LINED DITCH	TON	55.00

Δ SPECIALTY ITEMS

DESIGN DESIGNATION:
 DESIGN SPEED: 30 MPH
 HIGHWAY CLASS - MINOR COLLECTOR
 EXISTING STRUCTURE NO.: 097-4004
 PROPOSED STRUCTURE NO.: 097-3269
 CURRENT A.D.T. = 200
 CONTRACT NO. 99513



Know what's below.
 Call before you dig.

STATE OF ILLINOIS
 DEPARTMENT OF TRANSPORTATION
**PLANS FOR PROPOSED
 FEDERAL AID - S.T.R. PROJECT**

C.H. 13 WHITE COUNTY SECTION 09-00115-00-BR

PROJECT NO. RS-0193(052) JOB NO. C-99-549-09

CONTRACT # 99513 LIMEKILN CREEK TRIBUTARY

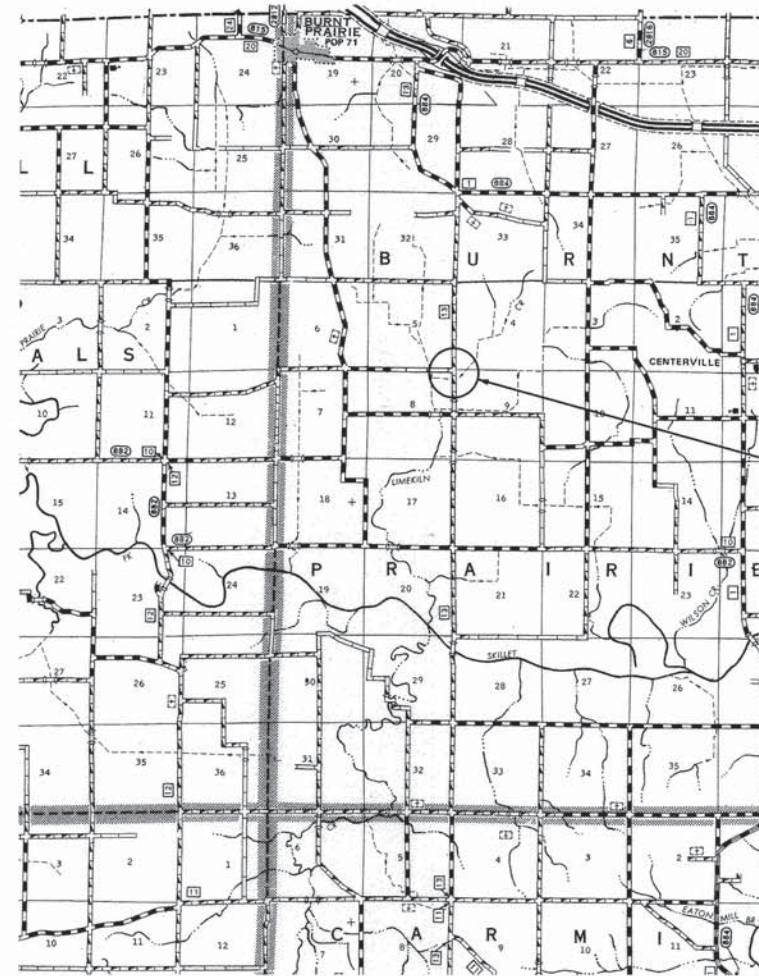

LAYOUT
 APPROXIMATE SCALE 1 INCH = 1 MILE



GROSS LENGTH	515.00 FT	0.098 MILES
OMISSIONS	0.00 FT	0.000 MILES
NET LENGTH	515.00 FT	0.098 MILES

CH	SECTION	COUNTY	TOTAL SHEETS	SHEET NO.
13	09-00115-00-BR	WHITE	15	1

FED. ROAD DIST. NO. 9 ILLINOIS
 PROJECT # RS-0193(052)
 JOB # C-99-549-09
 LEC JOB # H091L009W

FED. AID PROJECT
 CONTRACT # 99513
 LIMEKILN CREEK TRIB.

323 W. 3RD ST.
 P.O. BOX 160
 MT. CARMEL, IL 62863
 PHONE (618)-262-8651
 FAX: (618)-263-3327

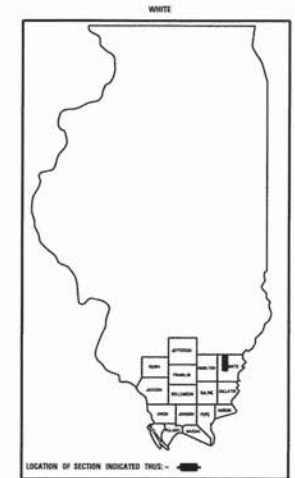

PROFESSIONAL DESIGN FIRM
 LAND SURVEY & PROFESSIONAL ENGINEERING CORPORATION
 184-000887
 (62-032435)(35-002769)



AARON M. MEFFORD
 NAME
 SIGNATURE
 DATE 12-12-13
 11-30-15 EXPIRES

PLAN	1" = 50'	0 50' 100'
PROFILE	1" = 50'	0 50' 100'
PROFILE VERT.	1" = 5'	0 5' 10'
CROSS SECTION	1" = 5'	0 5' 10'

SECTION 09-00115-00-BR
 BEGINS STATION 2+30

STATION 5+00, STRUCTURE NO. 097-3269
 A 45' LONG SINGLE SPAN PRECAST PRESTRESSED CONCRETE DECK BEAM BRIDGE (17" DEPTH), 24' ROADWAY, 0.00% GRADE, 10° RT. FWD. SKEW.

SECTION 09-00115-00-BR
 ENDS STATION 7+45

STATE OF ILLINOIS
 DEPARTMENT OF TRANSPORTATION

APPROVED 12/12/13
Brian A. Ray
 COUNTY ENGINEER

PASSED 1/16/2014
Dennis W. Hillbren
 ENGINEER OF LOCAL ROADS AND STREETS

RELEASING FOR BID
 BASED ON LIMITED
 REVIEW: Jan. 16, 2014

Jeffrey L. Keirn
 JEFFREY L. KEIRN, P.E.
 ACTING DEPUTY DIRECTOR OF HIGHWAYS
 REGION FIVE ENGINEER

COUNTY HIGHWAY 13
 OVER LIMEKILN CREEK TRIB.
 WHITE COUNTY, ILLINOIS

SHEET TITLE:

TITLE SHEET

SCALE: VARS

BY: AMM

DATE: 10/9/13

REV:

1 OF 15

SHEETS

SHEET NO.

1

GENERAL NOTES:

THIS SECTION SHALL BE CONSTRUCTED IN ACCORDANCE WITH THE PLANS, SPECIAL PROVISIONS AND "STANDARD SPECIFICATIONS FOR ROAD AND BRIDGE CONSTRUCTION", ADOPTED JANUARY 1, 2012.

THE WORK INVOLVED ON THIS SECTION CONSISTS OF THE REMOVAL OF THE EXISTING STRUCTURE, THE CONSTRUCTION OF A 45 FOOT LONG SINGLE SPAN PRECAST, PRESTRESSED CONCRETE DECK BEAM BRIDGE, EARTH APPROACHES, AGGREGATE SURFACE COURSE AND OTHER MISCELLANEOUS ITEMS NECESSARY TO COMPLETE THIS SECTION.

ALL ELEVATIONS ARE BASED ON U.S.G.S. MEAN SEA LEVEL DATUM.

IT SHALL BE THE CONTRACTOR'S RESPONSIBILITY TO CONTACT ALL THE UTILITIES, AFFECTING THE PROJECT, PRIOR TO CONSTRUCTION.

AGGREGATE SURFACE COURSE, TYPE B INCLUDES 24 TON FOR FILL NEXT TO THE BRIDGE, 58 TON FOR THE FIELD ENTRANCES, 165 TON FOR THE SIDEROAD AND 528 TON FOR THE ROADWAY.

TYPICAL CROSS SECTION PROPOSED

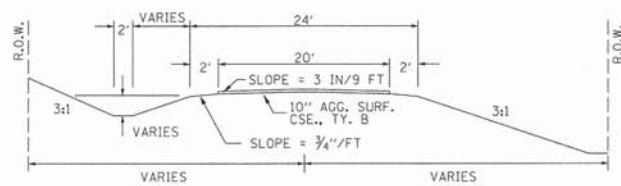

TYPICAL CROSS SECTION EXISTING

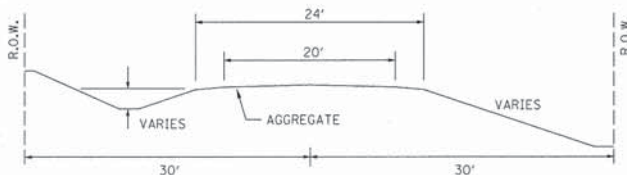

NOTE: CONSTRUCT SPECIAL DITCH

STA 2+80 TO STA 4+50 LT
STA 3+50 TO STA 4+20 RT
STA 5+11 TO STA 7+00 RT

UTILITIES:

J.U.L.I.E. 1-800-892-0123

FRONTIER

1-618-382-2887

NOTE: CONSTRUCT STONE LINED DITCH

STA 5+11 TO STA 6+00 RT (0.62 TON/LIN FT)
55 TON STONE LINED DITCH ALLOWED IN PROPOSAL.

SEE STONE LINED DITCH DETAIL ON SHEET 3.

STA. 4+83 LT FIELD ENTRANCE DETAIL

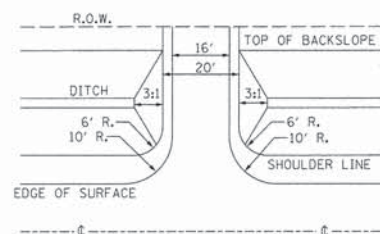

STA 4+44 RT FIELD ENTRANCE DETAIL

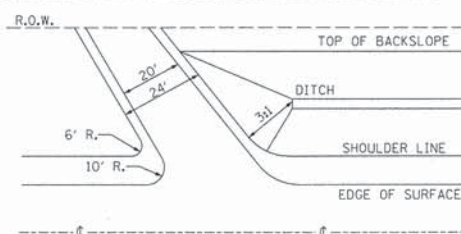

NOTE: CONSTRUCTION TRANSITION
STA. 2+30 TO STA 2+80
STA 7+00 TO STA 7+45

ALL QUANTITIES ARE INCLUDED IN THE PROPOSAL

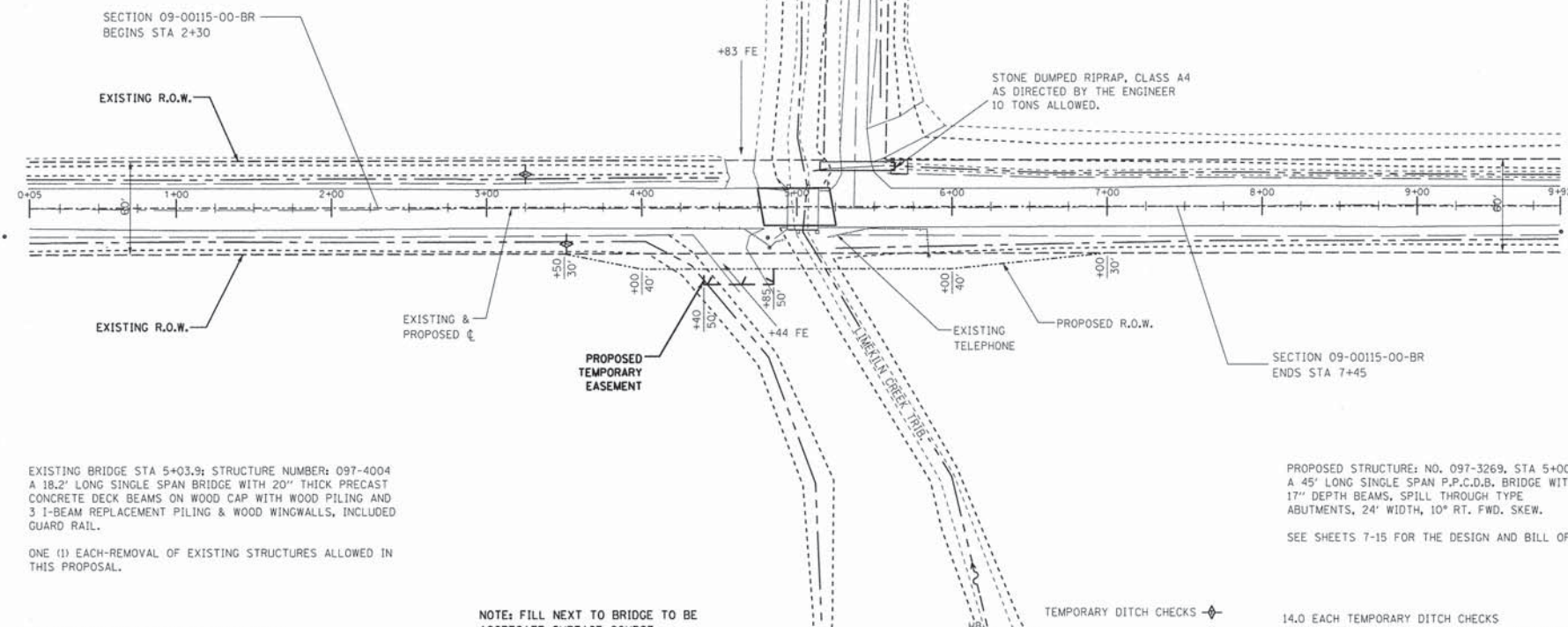

EXISTING BRIDGE STA 5+03.9; STRUCTURE NUMBER: 097-4004
A 18.2' LONG SINGLE SPAN BRIDGE WITH 20" THICK PRECAST CONCRETE DECK BEAMS ON WOOD CAP WITH WOOD PILING AND 3 1-BEAM REPLACEMENT PILING & WOOD WINGWALLS, INCLUDED GUARD RAIL.

ONE (1) EACH-REMOVAL OF EXISTING STRUCTURES ALLOWED IN THIS PROPOSAL.

PROPOSED STRUCTURE: NO. 097-3269, STA 5+00.
A 45' LONG SINGLE SPAN P.P.C.D.B. BRIDGE WITH 17" DEPTH BEAMS, SPILL THROUGH TYPE ABUTMENTS, 24' WIDTH, 10° RT. SKEW.

SEE SHEETS 7-15 FOR THE DESIGN AND BILL OF MATERIALS.

NOTE: FILL NEXT TO BRIDGE TO BE AGGREGATE SURFACE COURSE

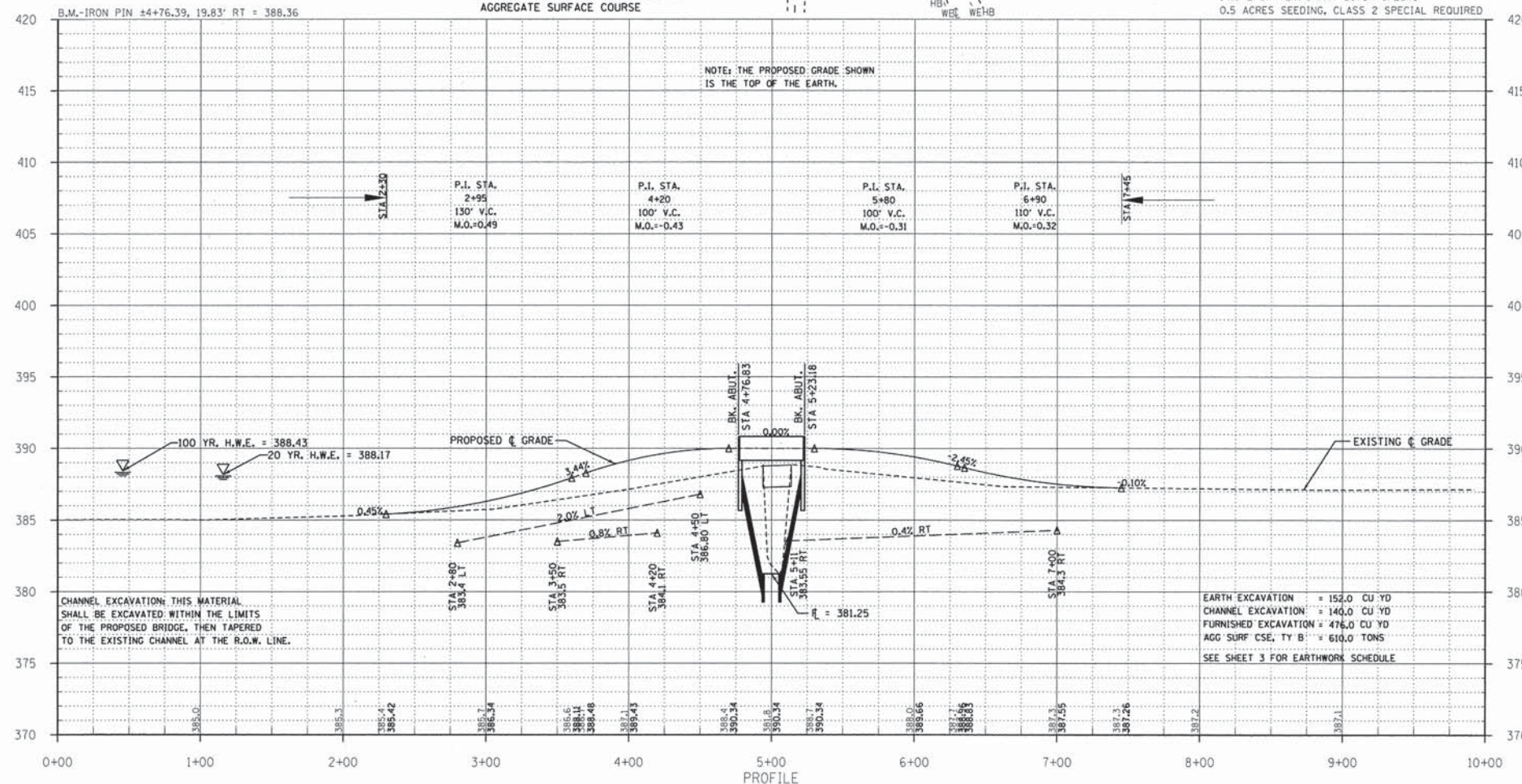

CHANNEL EXCAVATION: THIS MATERIAL SHALL BE EXCAVATED WITHIN THE LIMITS OF THE PROPOSED BRIDGE, THEN TAPERED TO THE EXISTING CHANNEL AT THE R.O.W. LINE.

EARTH EXCAVATION = 152.0 CU YD
CHANNEL EXCAVATION = 140.0 CU YD
FURNISHED EXCAVATION = 476.0 CU YD
AGG SURF CSE, TY B = 610.0 TONS
SEE SHEET 3 FOR EARTHWORK SCHEDULE

CH	SECTION	COUNTY	TOTAL SHEETS	SHEET NO.
13	09-00115-00-BR	WHITE	15	2

FED. ROAD DIST. NO. 9 ILLINOIS
LEC JOB # H081009WH Contract # 99513

323 W. 3RD ST.
P.O. BOX 160
MT. CARMEL, IL
62863
PHONE:
(618)-262-8651
FAX:
(618)-263-3327

PROFESSIONAL DESIGN FIRM
LAND SURVEY & PROFESSIONAL ENGINEERING CORPORATION
184-000887
(62-032435)(35-002769)



AARON M. MEFFORD
NAME
SIGNATURE
DATE
12-12-13
11-30-15 EXPIRES

COUNTY HIGHWAY 13
OVER LIMEKILN CREEK TRIB.
WHITE COUNTY, ILLINOIS

SHEET TITLE:
PLAN & PROFILE

SCALE:	VARIES
BY:	AMM
DATE:	12/09/13
REV:	

2 OF 15 SHEETS
SHEET NO. 2

CH	SECTION	COUNTY	TOTAL SHEETS	SHEET NO.
13	09-00115-00-BR	WHITE	15	3

323 W. 3RD ST.
P.O. BOX 160
MT. CARMEL, IL
62863
PHONE:
(618)-262-8651
FAX:
(618)-263-3327

PROFESSIONAL DESIGN FIRM
LAND SURVEY & PROFESSIONAL ENGINEERING CORPORATION
184-000887
(62-032435)(35-002769)



AARON M. MEFFORD
NAME
SIGNATURE
DATE
11-30-15
EXPIRES

COUNTY HIGHWAY 13
OVER LIMEKILN CREEK TRIB.
WHITE COUNTY, ILLINOIS

SHEET TITLE:
SIDEROAD PLAN & PROFILE
SCALE: VARIES
BY: AMM
DATE: 10/03
REV:
3 OF 15 SHEETS
SHEET NO. 3

NOTE: CONSTRUCTION TRANSITION
STA. 1+75 TO STA 0+55
ALL QUANTITIES ARE INCLUDED IN THE PROPOSAL

TYPICAL CROSS SECTION PROPOSED

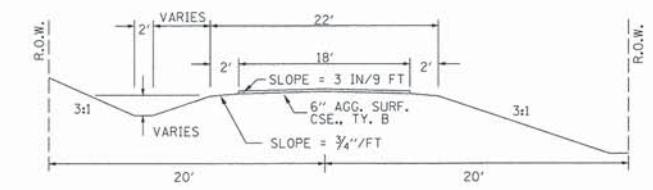

TYPICAL CROSS SECTION EXISTING

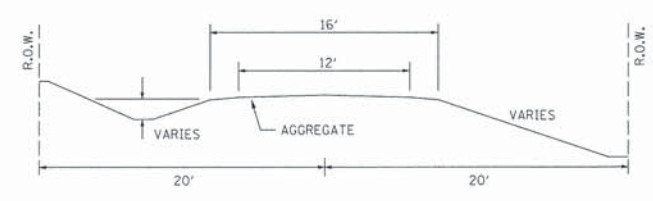

SIDEROAD RADII

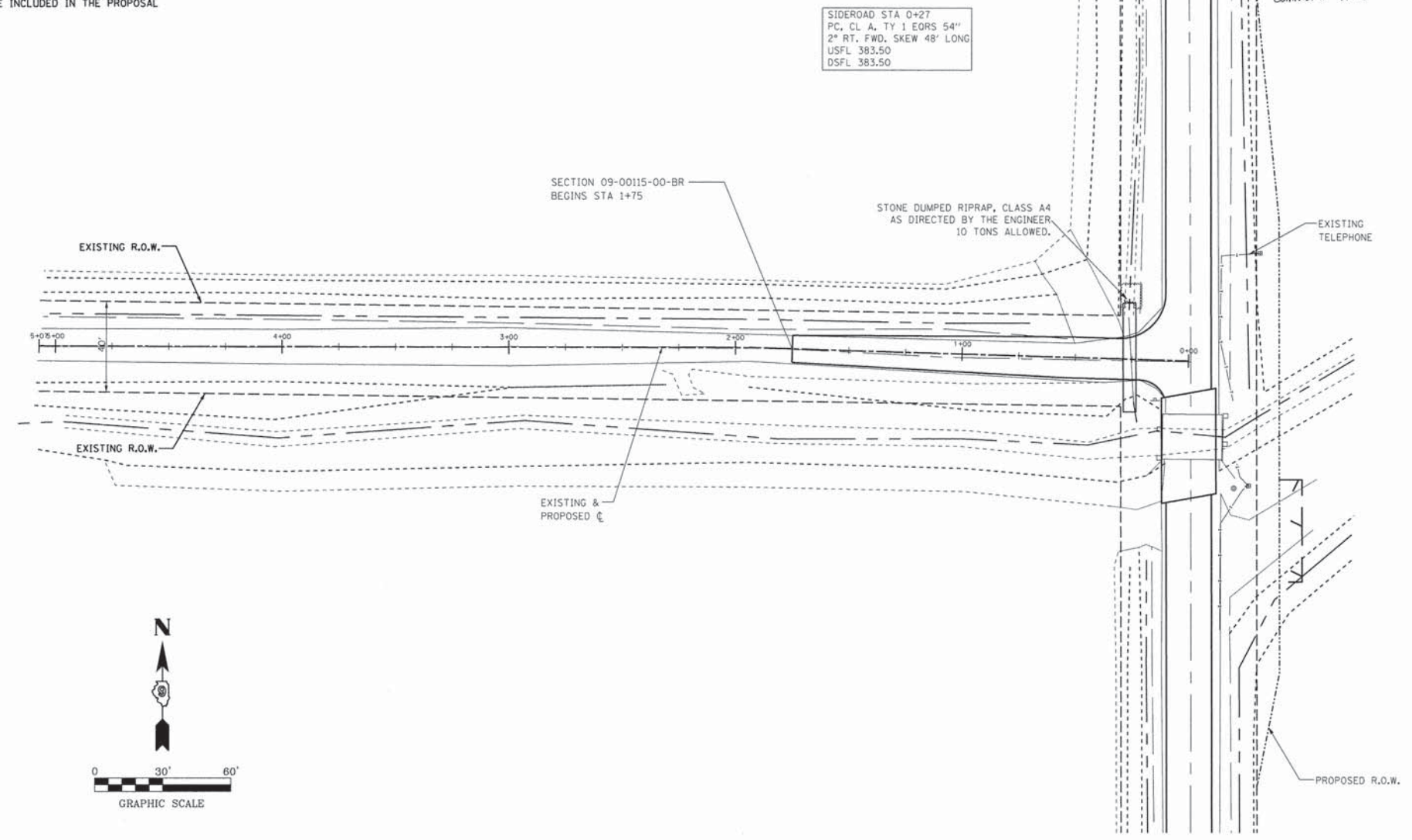
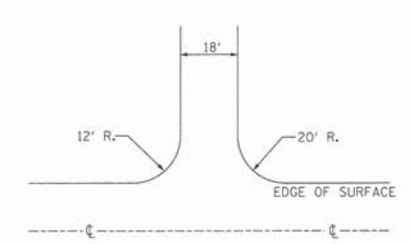

SIDEROAD STA 0+27
PC, CL A, TY 1 EORS 54"
2° RT. FWD, SKEW 48° LONG
USFL 383.50
DSFL 383.50

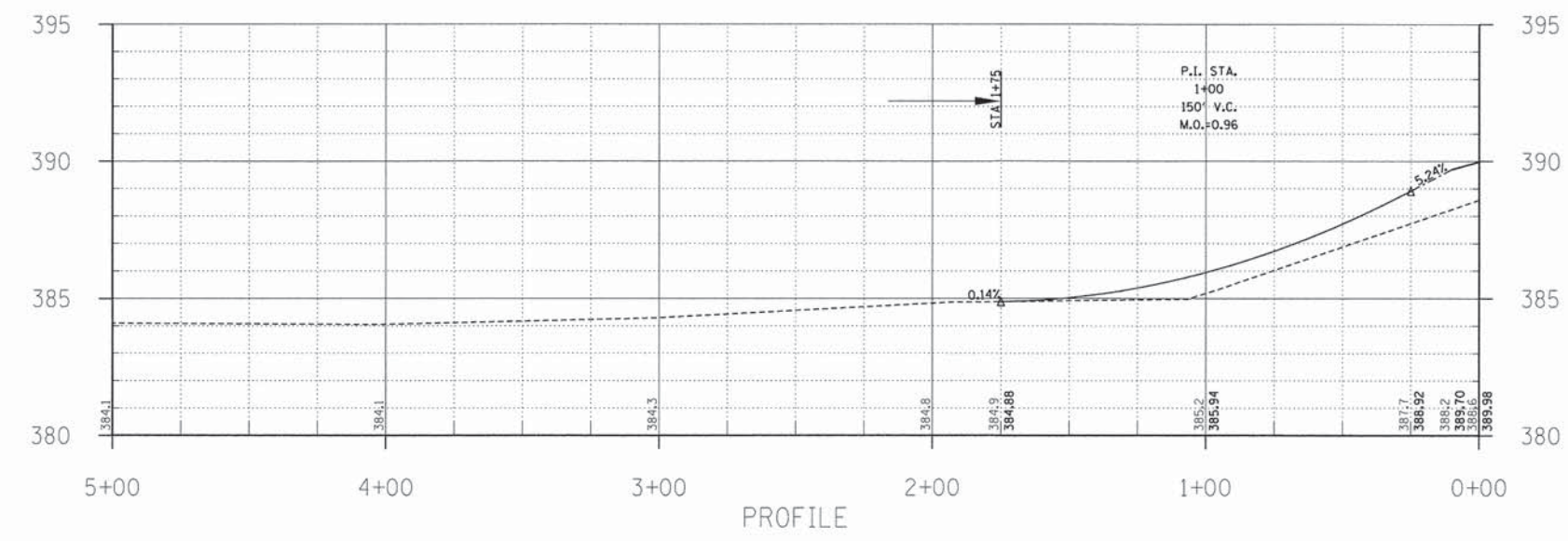
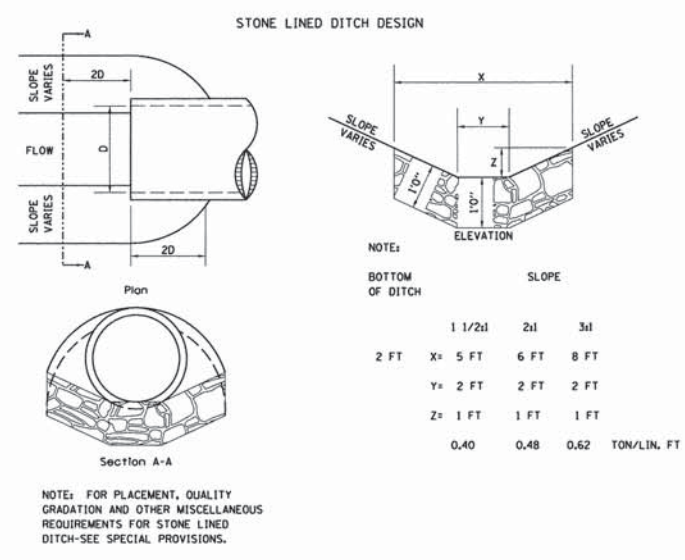

CH	SECTION	COUNTY	TOTAL SHEETS	SHEET NO.
13	09-00115-00-BR	WHITE	15	4
FED. ROAD DIST. NO. 9 ILLINOIS		FED. AID PROJECT		
PROJECT* RS-0193(052)		CONTRACT* 99513		
JOB NO. C-99-549-09		LIMEKILN CREEK TRIB.		
LEC JOB * H031L009MH				

323 W. 3RD ST.
P.O. BOX 160
MT. CARMEL, IL
62863
PHONE:
(618)-262-8651
FAX:
(618)-263-3327

PROFESSIONAL
DESIGN FIRM
LAND SURVEY &
PROFESSIONAL
ENGINEERING
CORPORATION
184-000887
(62-032435)(35-002769)



AARON M. MEFFORD
NAME
SIGNATURE
DATE
12-12-13
11-30-15
EXPIRES

COUNTY HIGHWAY 13
OVER LIMEKILN CREEK TRIB.
WHITE COUNTY, ILLINOIS

SHEET TITLE:

CROSS-SECTIONS

SCALE: 1" = 5'
BY: AMM
DATE: 08/13
REV:

4 OF 15
SHEETS

SHEET NO.
4

LOCATION	EARTH EXCAVATION	CHANNEL EXCAVATION	ESTIMATED UNSUITABLE MATERIAL	SUITABLE MATERIAL ADJUSTED FOR SHRINKAGE	EMBANKMENT	EARTHWORK BALANCE WASTE (+) OR SHORTAGE (-)
	CUBIC YARD	CUBIC YARD	CUBIC YARD	CUBIC YARD	CUBIC YARD	CUBIC YARD
STA 0+00 TO 4+76.8	63.1	0.0	0.0	47.3	317.9	-270.6
STA 4+76.8 TO 5+23.2	0.0	140.0	70.0	52.5	0.0	52.5
STA 5+23.2 TO 10+00	88.4	0.0	0.0	66.3	236.4	-170.1
SIDEROAD	0.0	0.0	0.0	0.0	61.4	-61.4
2 FIELD ENTRANCES	0.0	0.0	0.0	0.0	26.6	-26.6
TOTAL	151.5	140.0	70.0	166.1	642.3	-476.2

EARTHWORK SCHEDULE



2+00

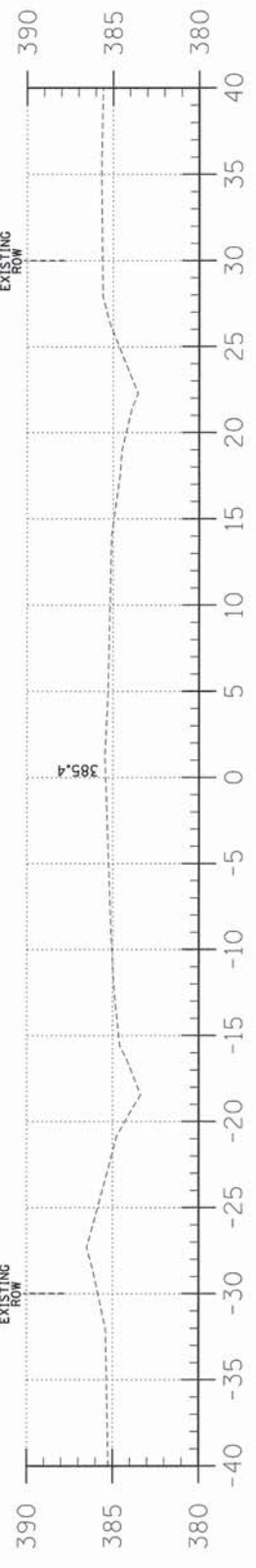

2+30

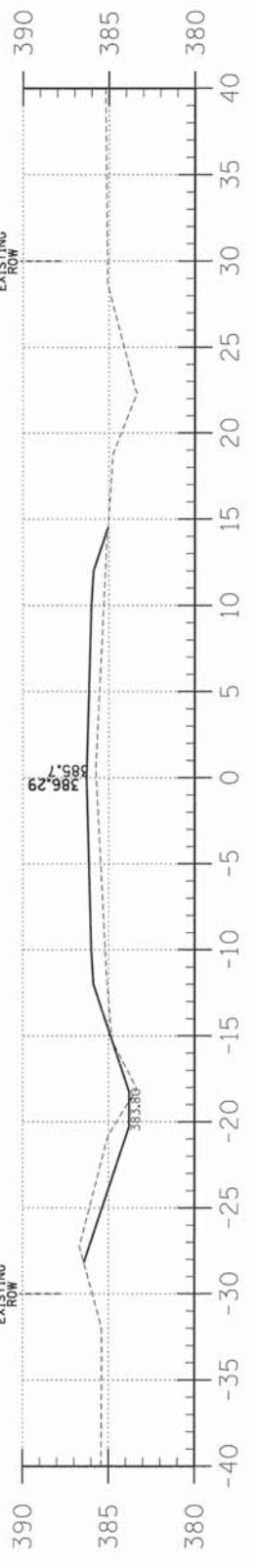

3+00

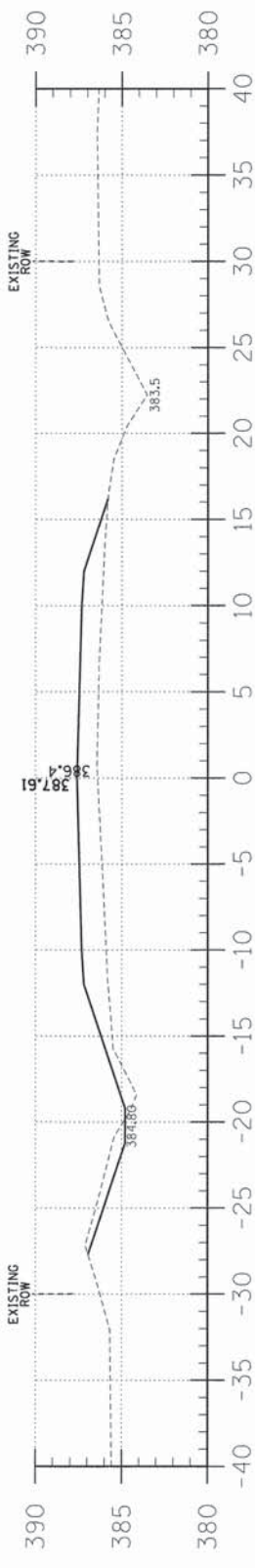

3+50

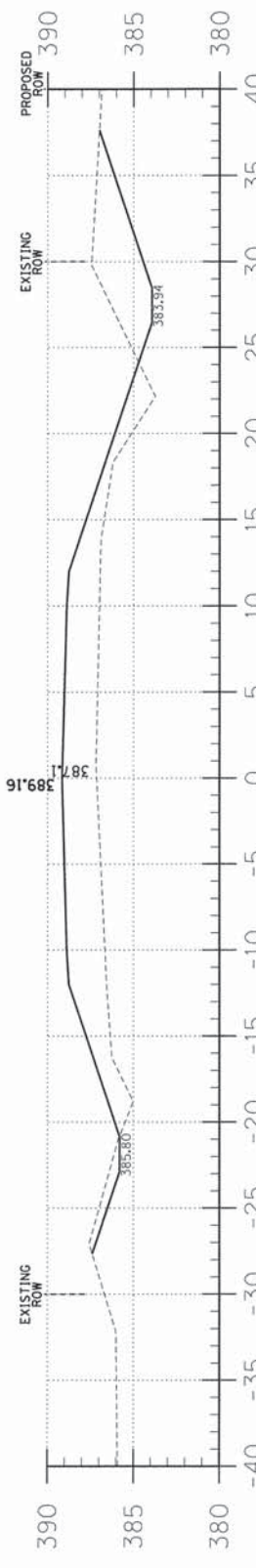

4+00

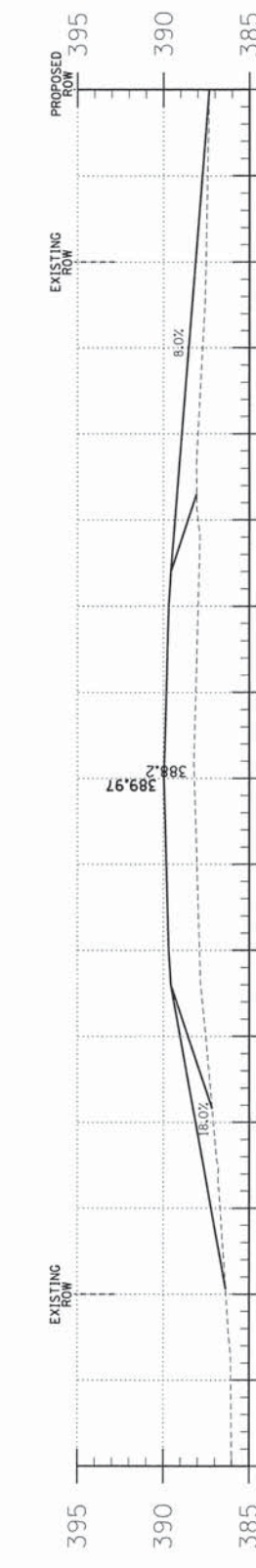

4+61

C = 0.0
F = 52.1

C = 25.7
F = 72.5

C = 3.7
F = 37.9

C = 6.7
F = 19.0

CH	SECTION	COUNTY	TOTAL SHEETS	SHEET NO.
13	09-00115-00-BR	WHITE	15	5
FED. ROAD DIST. NO. 9		ILLINOIS	FED. AID PROJECT	
PROJECT # RS-0193(052)		CONTRACT # 99513		
JOB NO. C-99-549-09		LIMEKILN CREEK TRIB.		

323 W. 3RD ST.
P.O. BOX 160
MT. CARMEL, IL
62863
PHONE:
(618)-262-8651
FAX:
(618)-263-3327

PROFESSIONAL
DESIGN FIRM
LAND SURVEY &
PROFESSIONAL
ENGINEERING
CORPORATION
184-00887
(62-032435)(35-002769)

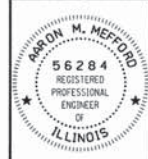

AARON M. MEFFORD
NAME
Aaron Mefford
SIGNATURE
12-12-13
DATE
11-30-15
EXPIRES

COUNTY HIGHWAY 13
OVER LIMEKILN CREEK TRIB.
WHITE COUNTY, ILLINOIS

SHEET TITLE:

CROSS-SECTIONS

SCALE: 1" = 5'
BY: AMM
DATE: 10/9/13
REV:

5 OF 15
SHEETS

SHEET NO.
5

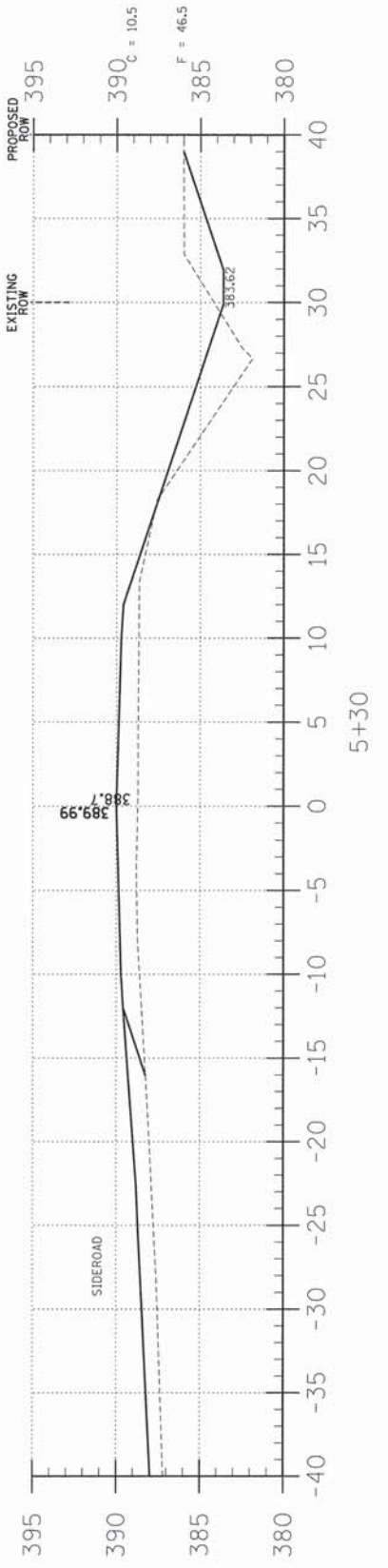
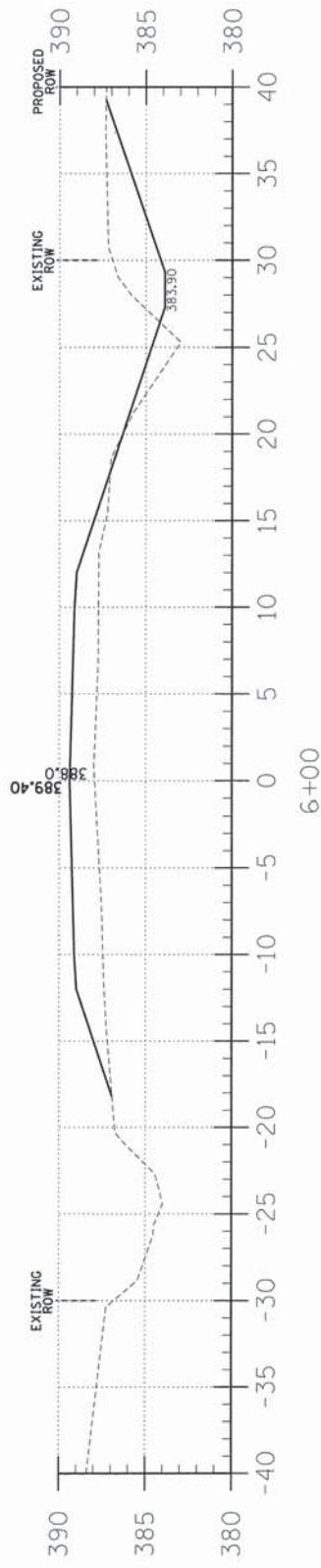
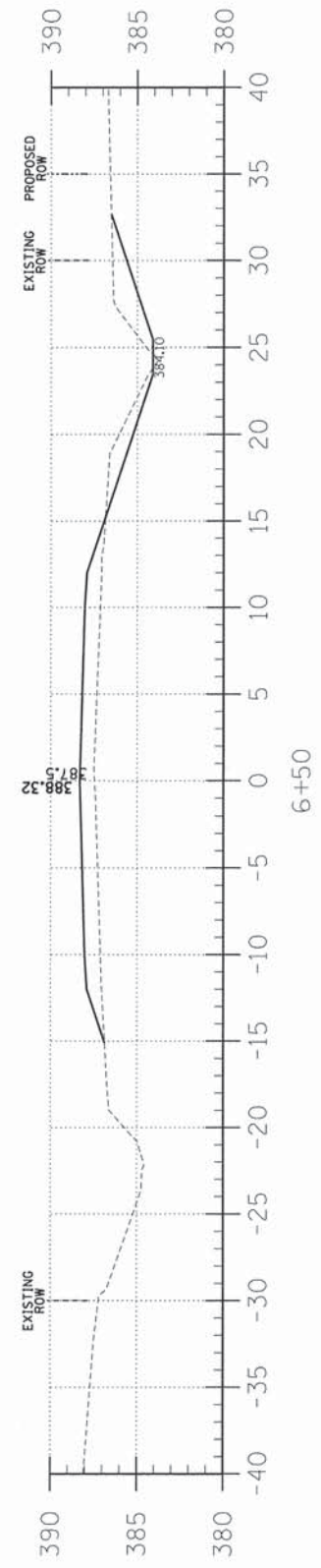
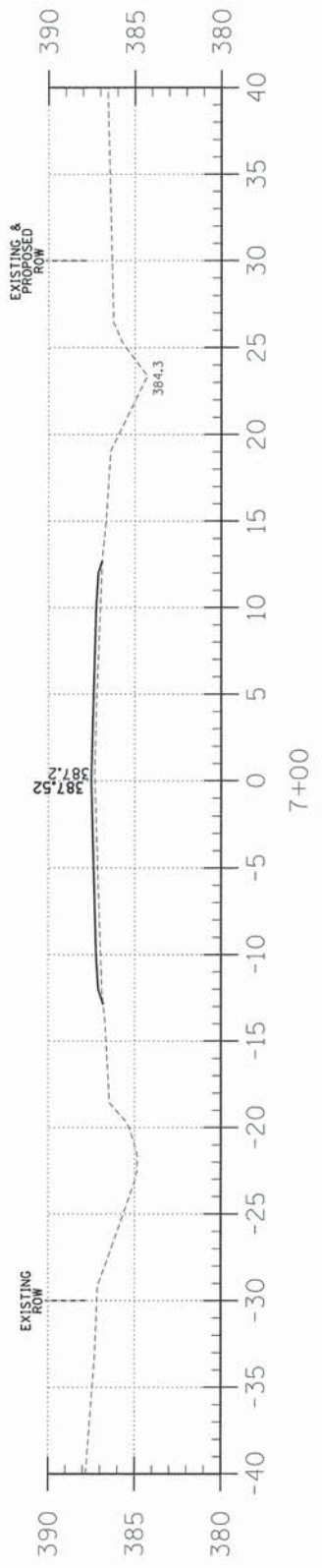
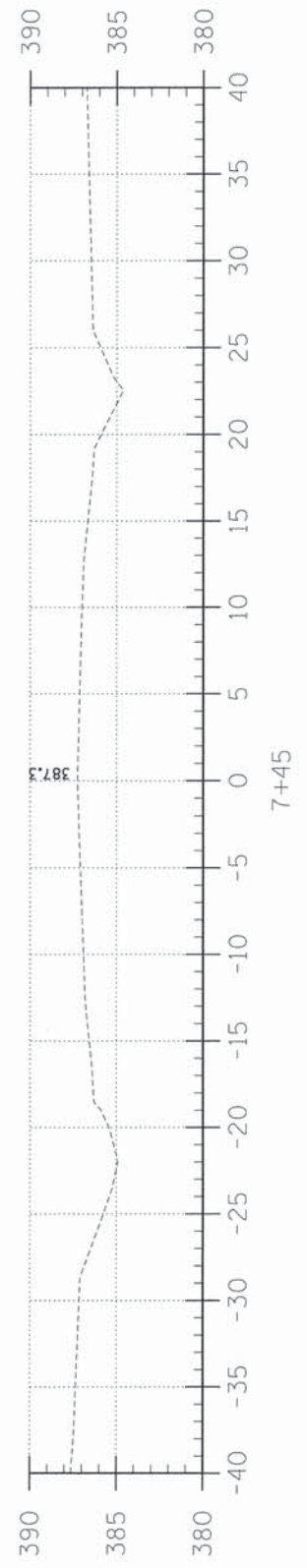
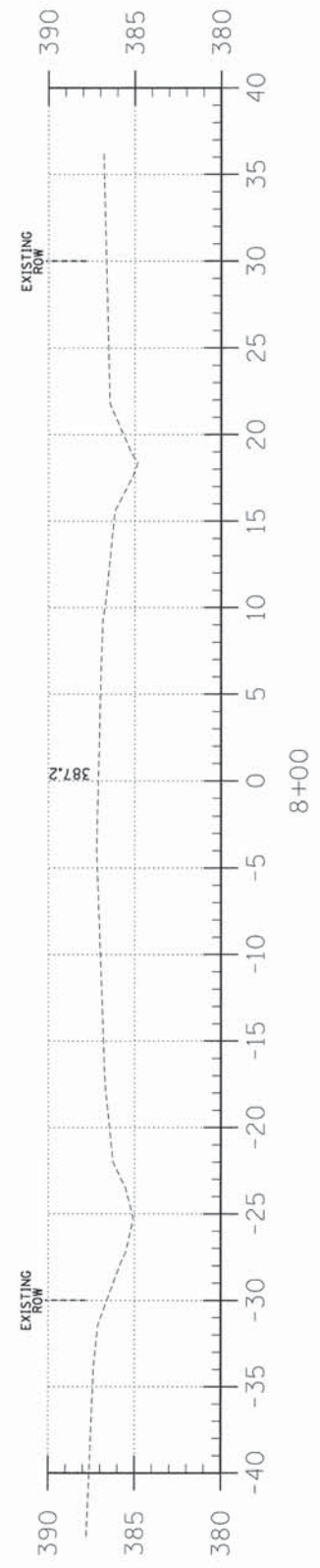

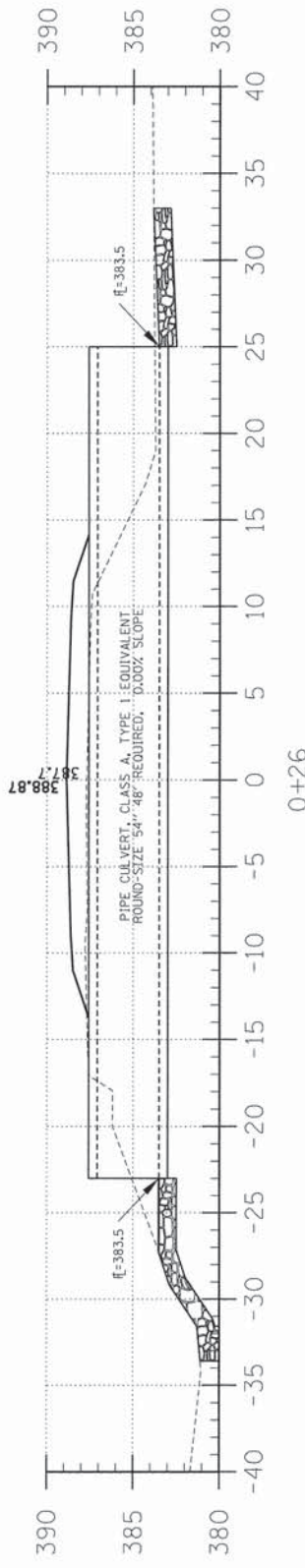
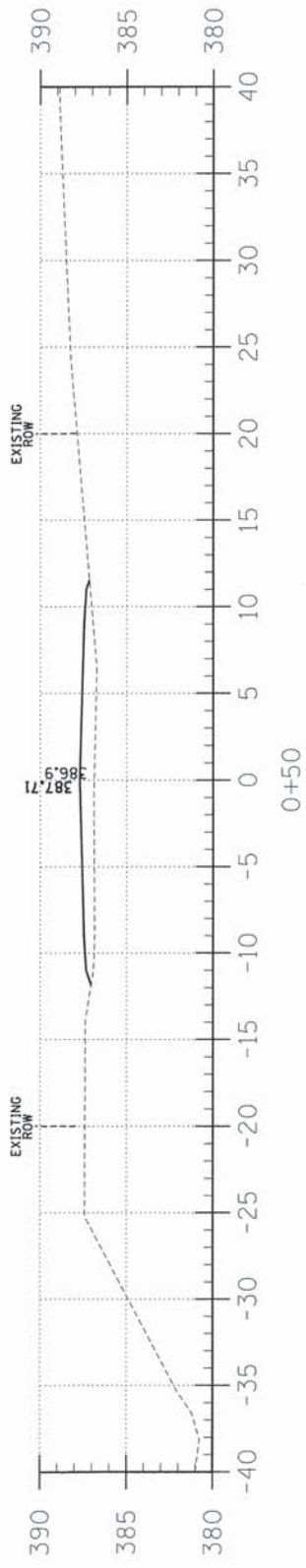
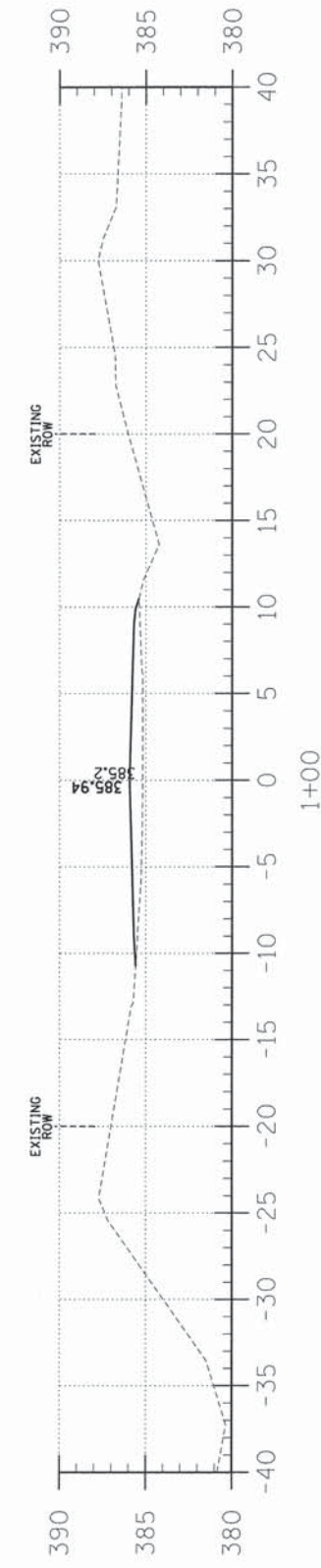
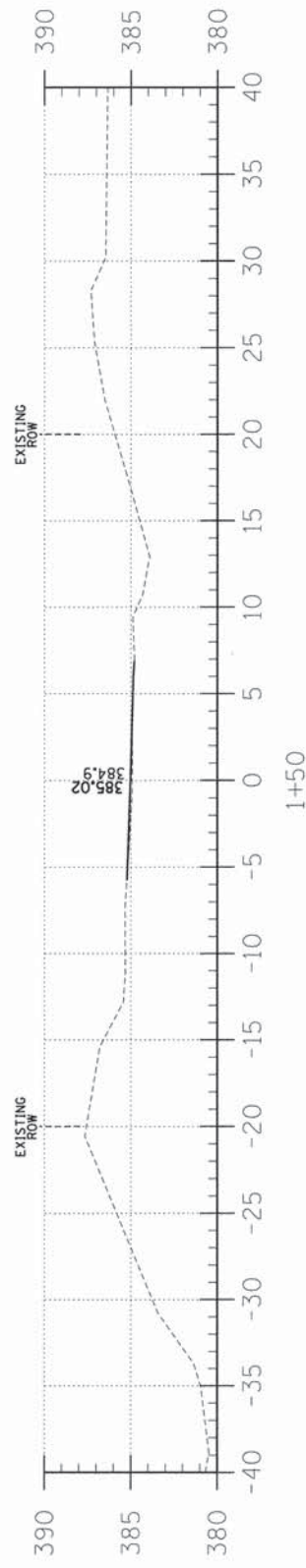
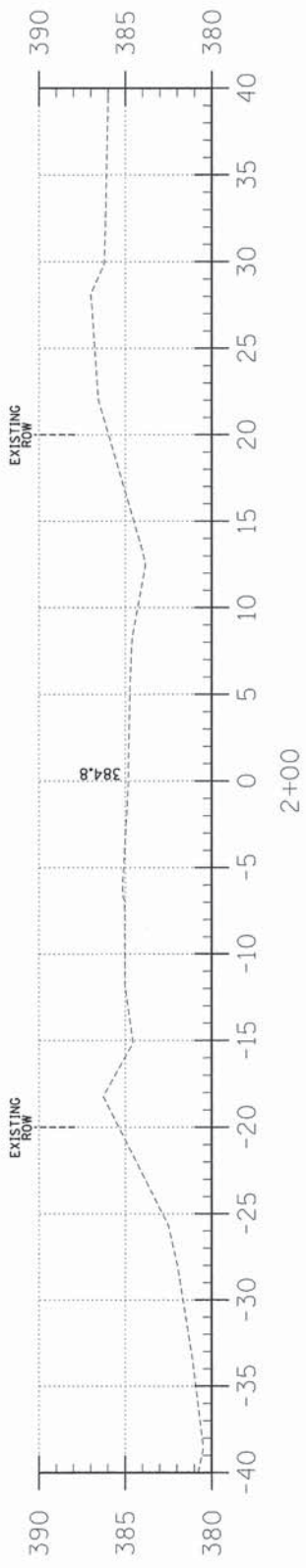

C = 0.0
F = 0.7

C = 0.0
F = 10.9

C = 0.0
F = 15.5

C = 0.0
F = 25.7

CH	SECTION	COUNTY	TOTAL SHEETS	SHEET NO.
13	09-00115-00-BR	WHITE	15	6
FED. ROAD DIST. NO. 9 ILLINOIS		FED. AID PROJECT		
PROJECT# RS-019310521		CONTRACT# 99513		
JOB NO. C-99-549-09		LIMEKILN CREEK TRIB.		
LEC JOB # H091L009WH				

323 W. 3RD ST.
P.O. BOX 180
MT. CARMEL, IL
62863
PHONE:
(618)-262-8651
FAX:
(618)-263-3327

PROFESSIONAL
DESIGN FIRM
LAND SURVEY &
PROFESSIONAL
ENGINEERING
CORPORATION
184-000887
(62-032435)(35-002769)



AARON M. MEFFORD
NAME
Aaron Mefford
SIGNATURE
12-12-13
DATE
11-30-15
EXPIRES

COUNTY HIGHWAY 13
OVER LIMEKILN CREEK TRIB.
WHITE COUNTY, ILLINOIS

SHEET TITLE:

CROSS-SECTIONS

SCALE: 1" = 5'
BY: AMM
DATE: 09/13
REV:

6 OF 15
SHEETS

SHEET NO.
6

SIDE ROAD

BENCHMARK: Iron Pin ±4+76.39, 19.83' Rt. = 388.36

EXISTING STRUCTURE: Structure NO. 097-4004: An 18.2' long single span bridge with 20" thick precast concrete deck beams on wood cap with wood piling and 3 I-beam replacement piling & wood wingwalls.

Structure closed to traffic during construction.

No Salvage

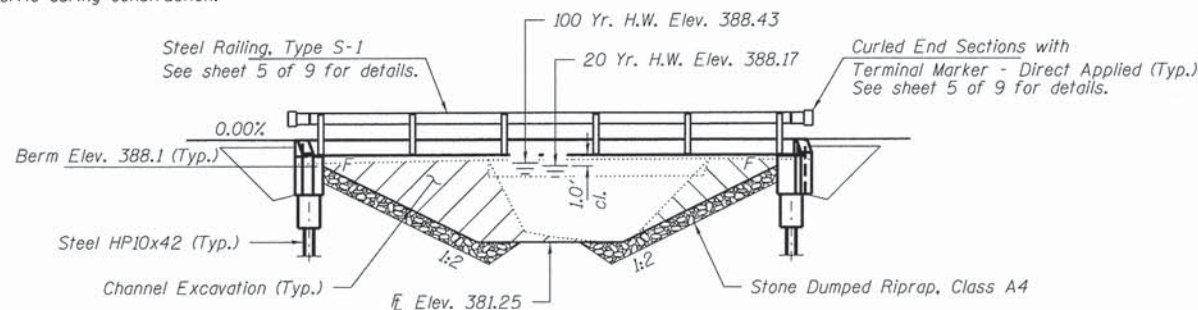

ELEVATION

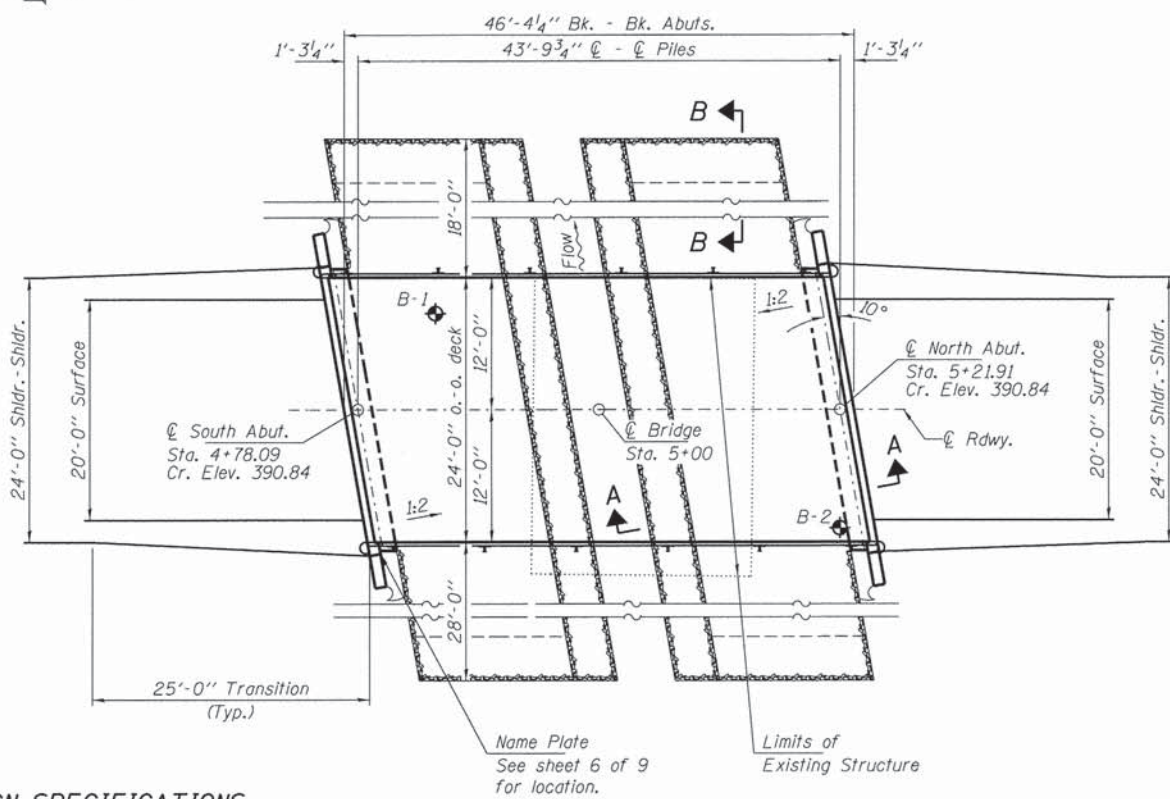

PLAN

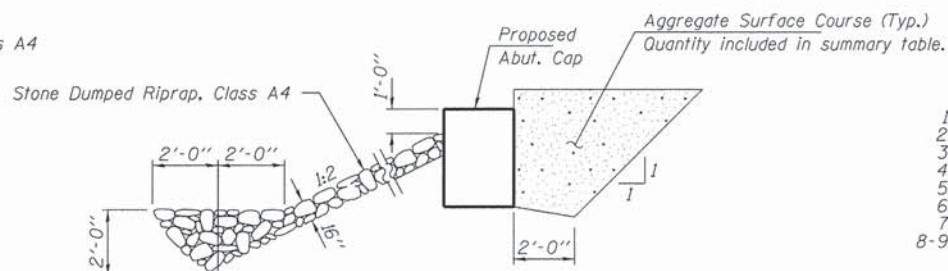

SECTION A-A

Note: See Special Provisions for Stone Dumped Riprap, Class A4.

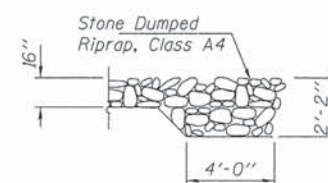

SECTION B-B

INDEX OF STRUCTURE SHEETS

1. General Plan & Elevation
2. 17"x48" PPC Deck Beam
3. 17"x48" PPC Deck Beam Details
4. Superstructure Details
5. Steel Railing, Type S-1
6. Abutments
7. HP Pile Details
- 8-9. Borings

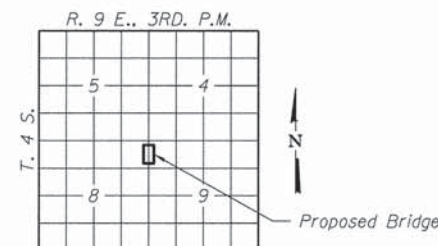

LOCATION SKETCH

BUILT 201_ BY
WHITE COUNTY
C.H. 13
SEC. 09-00115-00-BR
STR. NO. 097-3269
LOADING HL-93

NAME PLATE
See Std. 515001

DESIGN SPECIFICATIONS

2012 AASHTO LFRD Bridge Design Specifications, 6th Edition with all applicable interims.

LOADING HL-93

Allow 50#/sq. ft. for future wearing surface.

DESIGN STRESSES

FIELD UNITS

f'c = 3,500 psi
fy = 60,000 psi (Reinf.)

PRECAST PRESTRESSED UNITS

f'c = 6,000 psi
f'ci = 5,000 psi
fpu = 270,000 psi (1/2" low lax. strands)
fpbt = 201,960 psi (1/2" low lax. strands)
fy = 60,000 psi (Reinf.)

SEISMIC DATA

Seismic Performance Zone (SPZ) = 2
Design Spectral Acceleration at 1.0 sec. (SD1) = 0.291g
Design Spectral Acceleration at 0.2 sec. (SDS) = 0.695g
Soil Site Class = D

WATERWAY INFORMATION

Flood	Freq. Yr.	Q C.F.S.	Opening Sq. Ft.		Natural H.W.E.	Head - Ft.		Headwater El.	
			Exist.	Prop.		Exist.	Prop.	Exist.	Prop.
Design	20	958	78.7	187.1	388.17	-	-	-	-
Base/Max. Calc.	100	1500	78.7	197.9	388.43	0.09	0.07	388.52	388.50

Approach Flow: 390 Sq. Ft. @ 528 Sq. Ft.
Low Water Approach Required.

Design Scour Elevations (ft.)	S. Abut.		N. Abut.	
	Q100	385.6	Q100	385.6

I certify that to the best of my knowledge, information and belief, this bridge design is structurally adequate for the design loading shown on the plans. The design is an economical one for the style of structure and complies with requirements of the current "AASHTO LFRD Specifications."

Steven W. Megginson 12/06/2013
ILLINOIS STRUCTURAL ENGINEER NO. 081-6064



Expires 11-30-2014

TOTAL BILL OF MATERIAL

ITEM	UNIT	SUPER	SUB	TOTAL
Channel Excavation	Cu. Yd.			140
Stone Dumped Riprap, Class A4	Ton			240
Removal of Existing Structures	Each			1
Concrete Structures	Cu. Yd.		21.6	21.6
Concrete Encasement	Cu. Yd.		2.8	2.8
Precast Prestressed Concrete Deck Beams (17" Depth)	Sq. Ft.	1,080		1,080
Reinforcement Bars	Pound		2,400	2,400
Steel Railing, Type S-1	Foot	88		88
Furnishing Steel Piles HPI0x42	Foot		525	525
Driving Piles	Foot		525	525
Test Pile Steel HPI0x42	Each		1	1
Name Plates	Each		1	1
Terminal Marker - Direct Applied	Each	4		4

FILE NAME = #FILE#	USER NAME =	DESIGNED - L.A.P.	REVISED -
HAMPTON, LENZINI AND RENWICK, INC.		CHECKED - S.W.M.	REVISED -
3883 STEVENSON DRIVE, SUITE 301		DRAWN - R.D.H.	REVISED -
SPRINGFIELD, ILLINOIS 62703		CHECKED - D.A.B.	REVISED -
ILLINOIS PROFESSIONAL DESIGN FIRM			
LS / PE / SE CORP. 184-000989			

STATE OF ILLINOIS
WHITE COUNTY HIGHWAY DEPARTMENT

GENERAL PLAN & ELEVATION
STRUCTURE NO. 097-3269

SHEET NO. 1 OF 9 SHEETS

C.H.	SECTION	COUNTY	TOTAL SHEETS	SHEET NO.
13	09-00115-00-BR	WHITE	15	7
CONTRACT NO. 99513			ILLINOIS FED. AID PROJECT	

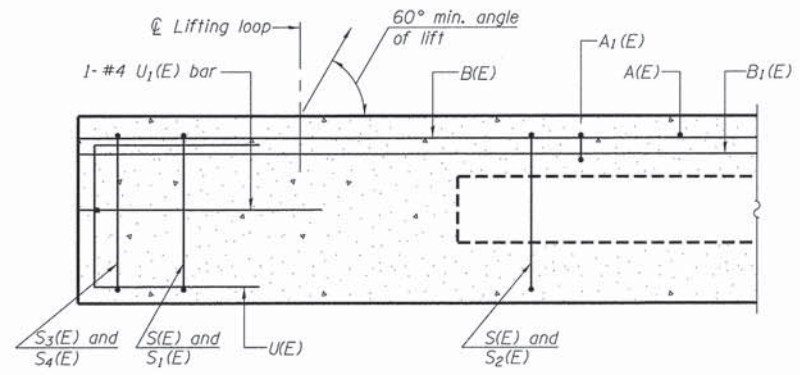

SECTION A-A

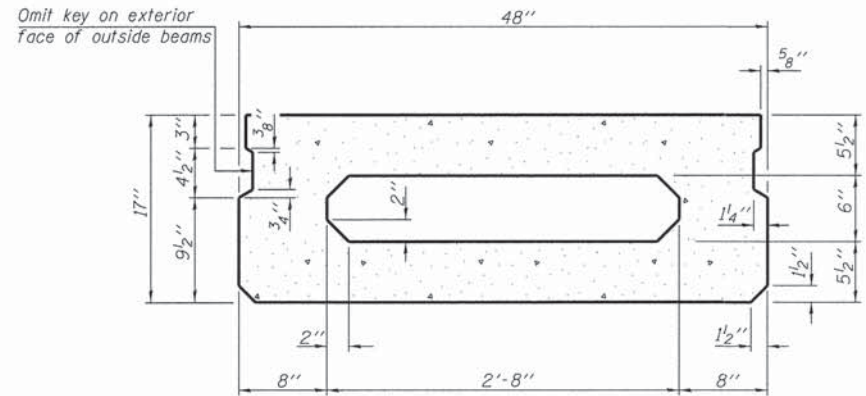

SECTION B-B
(Showing dimensions)

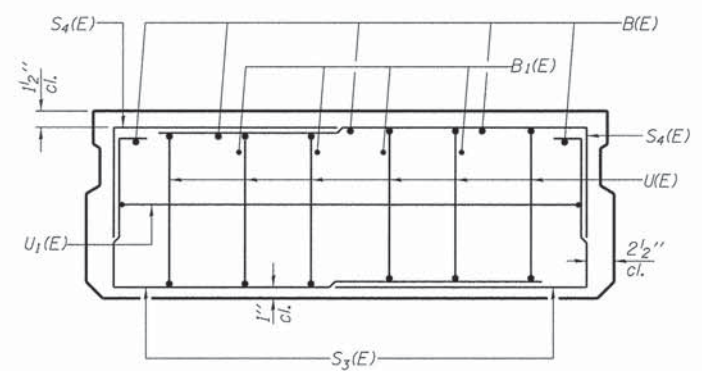

VIEW C-C

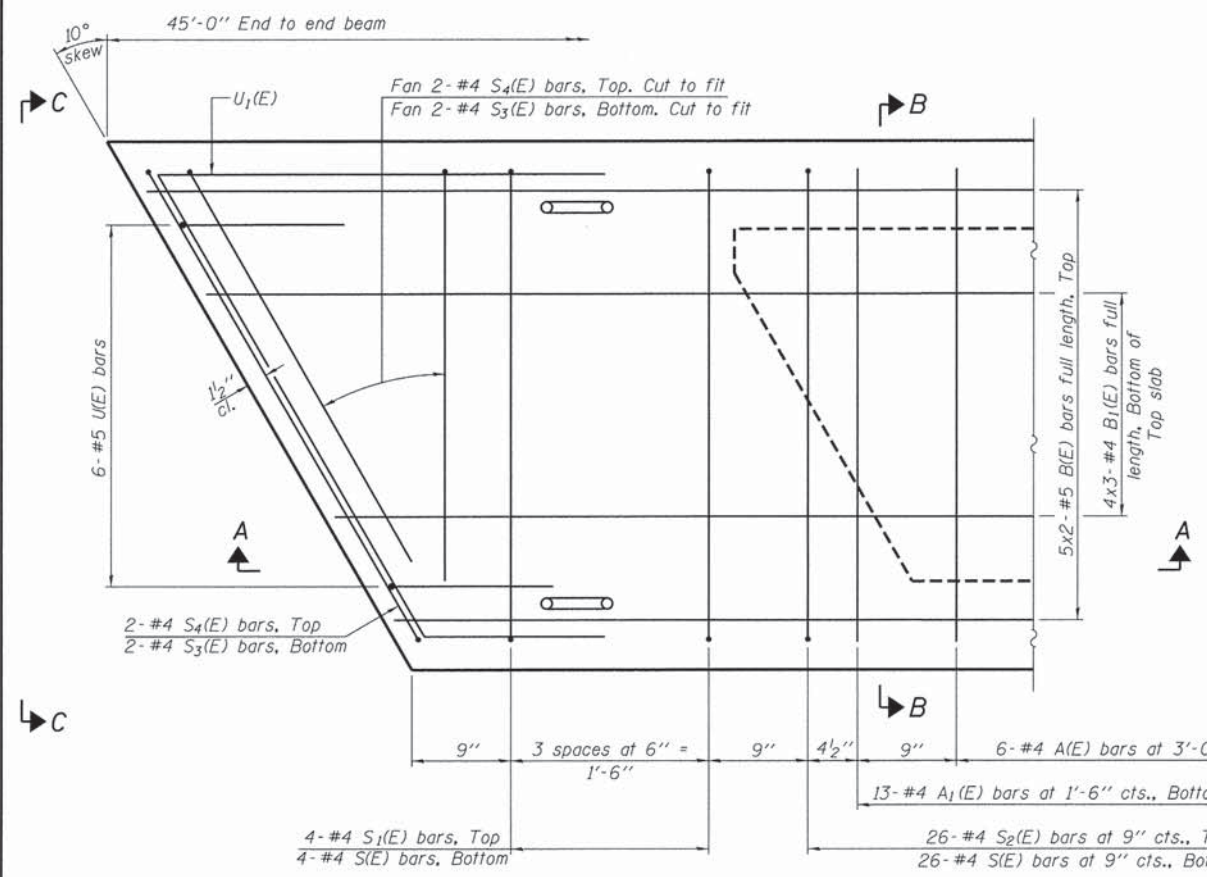

PLAN VIEW

Notes:
Spacing of S1(E) and S2(E) bars may be adjusted up to 4" in the immediate area of the transverse tie diaphragms to miss the block outs for the transverse ties.
Bars indicated thus 5x2-#5 etc. indicates 5 lines of bars with 2 lengths per line.

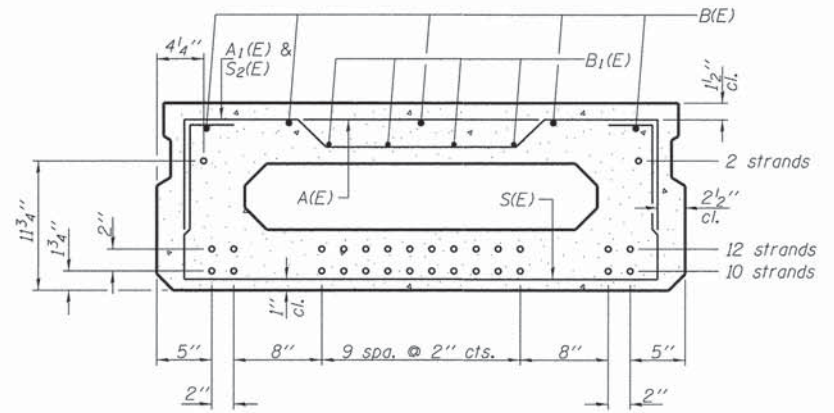

SECTION B-B
(Showing reinforcement and permissible strand locations)

Note: Place the number of strands specified in each row symmetrically about the centerline of beam in the permissible strand locations shown.

MINIMUM BAR LAP

#4 bar = 2'-0"
#5 bar = 2'-6"

BAR LIST
ONE BEAM ONLY
(For information only)

Bar	No.	Size	Length	Shape
A(E)	13	#4	3'-7"	—
A1(E)	26	#4	3'-10"	—
B(E)	10	#5	23'-8"	—
B1(E)	12	#4	16'-3"	—
S(E)	60	#4	6'-9"	U
S1(E)	8	#4	5'-3"	U
S2(E)	52	#4	5'-6"	U
S3(E)	8	#4	4'-4"	U
S4(E)	8	#4	3'-7"	U
U(E)	12	#5	3'-8"	U
U1(E)	2	#4	6'-8"	U

Note: See sheet 3 & 4 of 9 for additional details and Bill of Material.

PD-1748-R 7-1-10

FILE NAME = #FILE#	USER NAME =	DESIGNED - L.A.P.	REVISED -
HAMPTON, LENZINI AND RENWICK, INC. 3055 STEVENSON DRIVE, SUITE 201 SPRINGFIELD, ILLINOIS 62793		CHECKED - S.W.M.	REVISED -
ILLINOIS PROFESSIONAL DESIGN FIRM L3 / PE / SE COMP. 194.000958	PLOT SCALE =	DRAWN - R.D.H.	REVISED -
	PLOT DATE = #DATE#	CHECKED - D.A.B.	REVISED -

STATE OF ILLINOIS
WHITE COUNTY HIGHWAY DEPARTMENT

17" x 48" PPC DECK BEAM
STRUCTURE NO. 097-3269

SHEET NO. 2 OF 9 SHEETS

C.H.	SECTION	COUNTY	TOTAL SHEETS	SHEET NO.
13	09-00115-00-BR	WHITE	15	8
CONTRACT NO. 99513				
ILLINOIS FED. AID PROJECT				

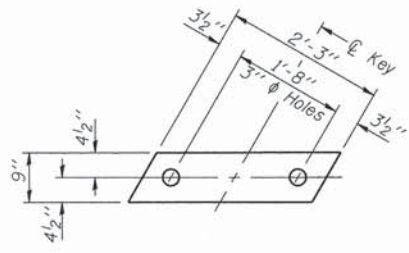

FABRIC BEARING PAD
(Interior - 10 Req'd.)

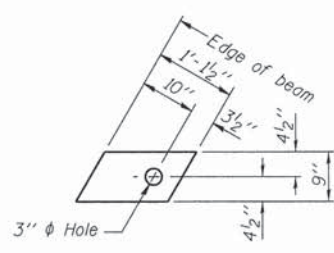

FABRIC BEARING PAD
(Exterior - 4 Req'd.)

Notes:
All bearing pads shall be 1" thick.
Omit holes when using expansion bearings.
Expansion bearing pad shall be bonded to the substructure.

FIXED

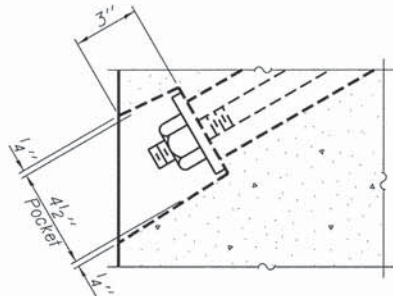

SECTION A-A

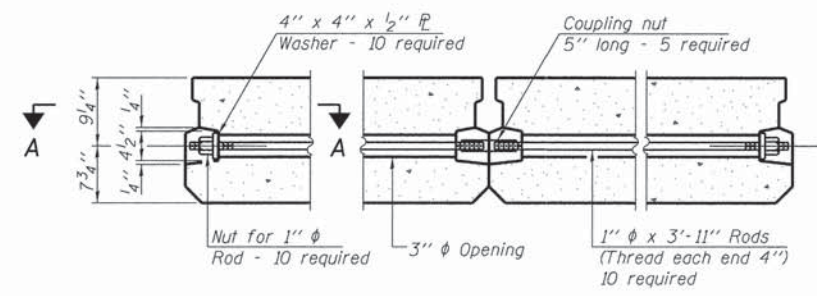

TYPICAL TRANSVERSE TIE ASSEMBLY

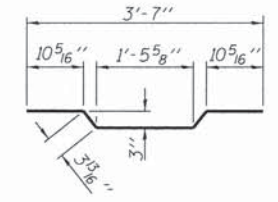

BAR A1(E)

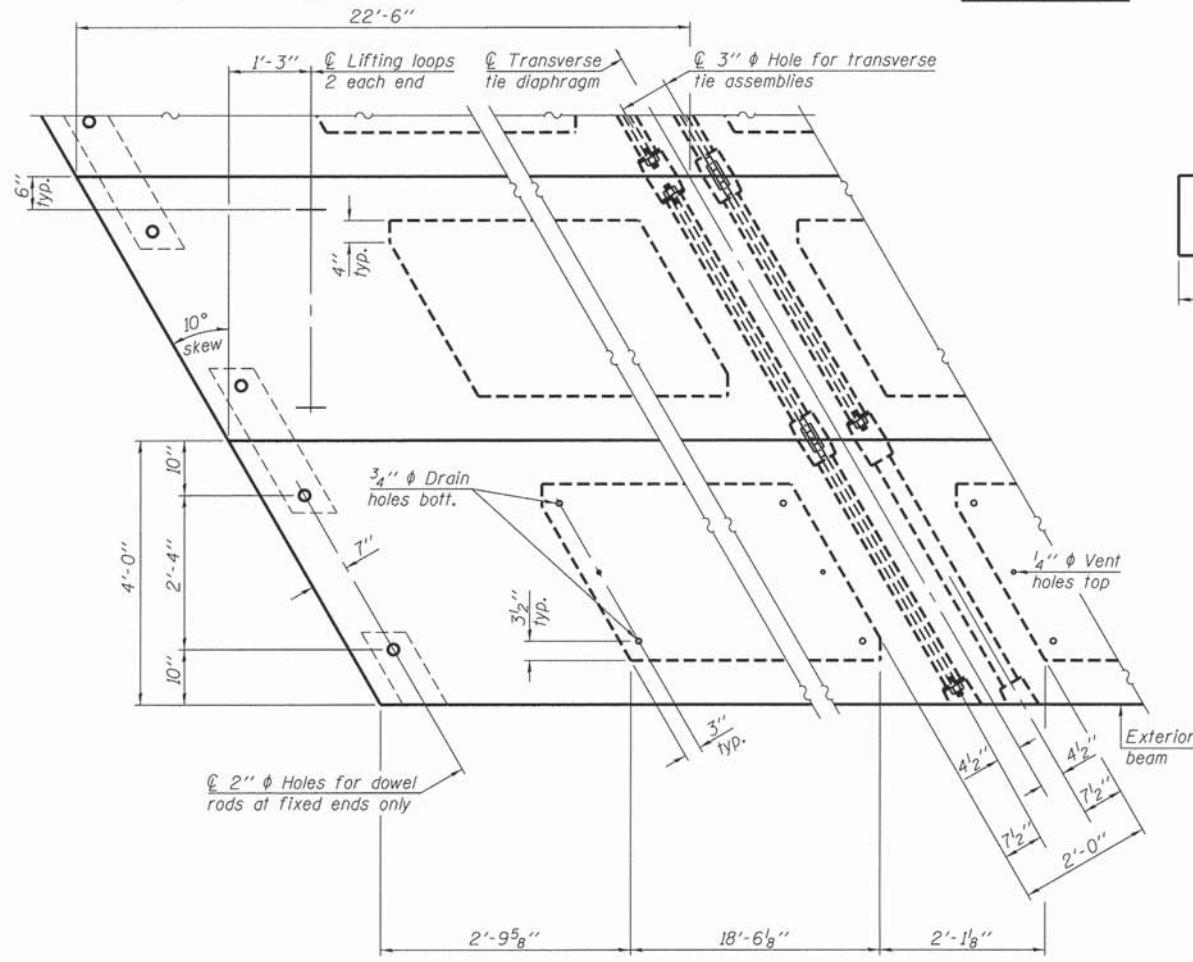

PLAN VIEW

NOTES

Prestressing steel shall be uncoated high strength, low relaxation 7-wire strand, Grade 270. The nominal diameter shall be 1/2" and the nominal cross-sectional area shall be 0.153 sq. in. The 1" rods in the transverse tie assembly shall be tightened to a snug fit and the threads set. Pockets on exterior faces of bridge shall be filled with grout after transverse tie assembly is in place.
Reinforcement bars shall conform to ASTM A 706, Grade 60. (See Special Provisions).
Two 1/8" fabric adjusting shims of the dimensions of the exterior bearing pad shall be provided for each bearing pad location.
A minimum 2 1/2" diameter lifting pin shall be used to engage the lifting loops during handling.
Corrosion inhibitor, per Article 1020.05(b)(12) and 1021.07 of the Standard Specifications, shall be used in the concrete for precast prestressed concrete deck beams.
Compressive strength of prestressed concrete, f'c, shall be 6000 psi.
Compressive strength of prestressed concrete at release, f'ci, shall be 5000 psi.
Reinforcement bars designated (E) shall be epoxy coated.

STATE OF ILLINOIS
WHITE COUNTY HIGHWAY DEPARTMENT

ILLINOIS PROFESSIONAL DESIGN FIRM

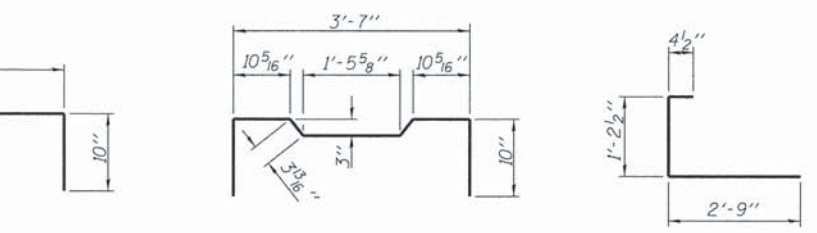

BAR S(E)

BAR S1(E)

BAR S2(E)

BAR S3(E)

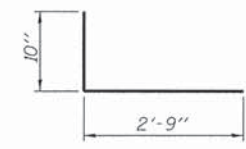

BAR S4(E)

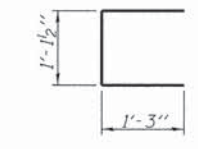

BAR U(E)

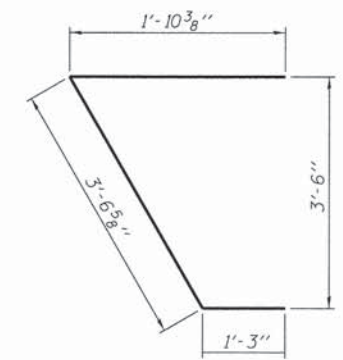

BAR U1(E)

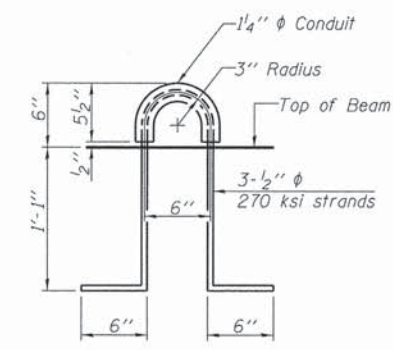

LIFTING LOOP DETAIL

BILL OF MATERIAL

Precast Prestressed Conc. Deck Bms. (17" depth)	Sq. Ft.	1,080
---	---------	-------

Note: Connect beams in pairs with the transverse tie configuration shown.

PD-1748-RD 7-1-10

FILE NAME * #FILES*	USER NAME *	DESIGNED - L.A.P.	REVISED -
HAMPTON, LENZINI AND RENWICK, INC.		CHECKED - S.W.M.	REVISED -
3095 STEVENSON DRIVE, SUITE 201		DRAWN - R.D.H.	REVISED -
SPRINGFIELD, ILLINOIS 62781		CHECKED - D.A.B.	REVISED -
ILLINOIS PROFESSIONAL DESIGN FIRM			
LS / PE / SE CORP. 184.000959			

PLOT SCALE *	DESIGNED - L.A.P.	REVISED -
PLOT DATE * #DATE*	CHECKED - S.W.M.	REVISED -
	DRAWN - R.D.H.	REVISED -
	CHECKED - D.A.B.	REVISED -

17" x 48" PPC DECK BEAM DETAILS
STRUCTURE NO. 097-3269

SHEET NO. 3 OF 9 SHEETS

C.H.	SECTION	COUNTY	TOTAL SHEETS	SHEET NO.
13	09-00115-00-BR	WHITE	15	9
CONTRACT NO. 99S13				
ILLINOIS FED. AID PROJECT				

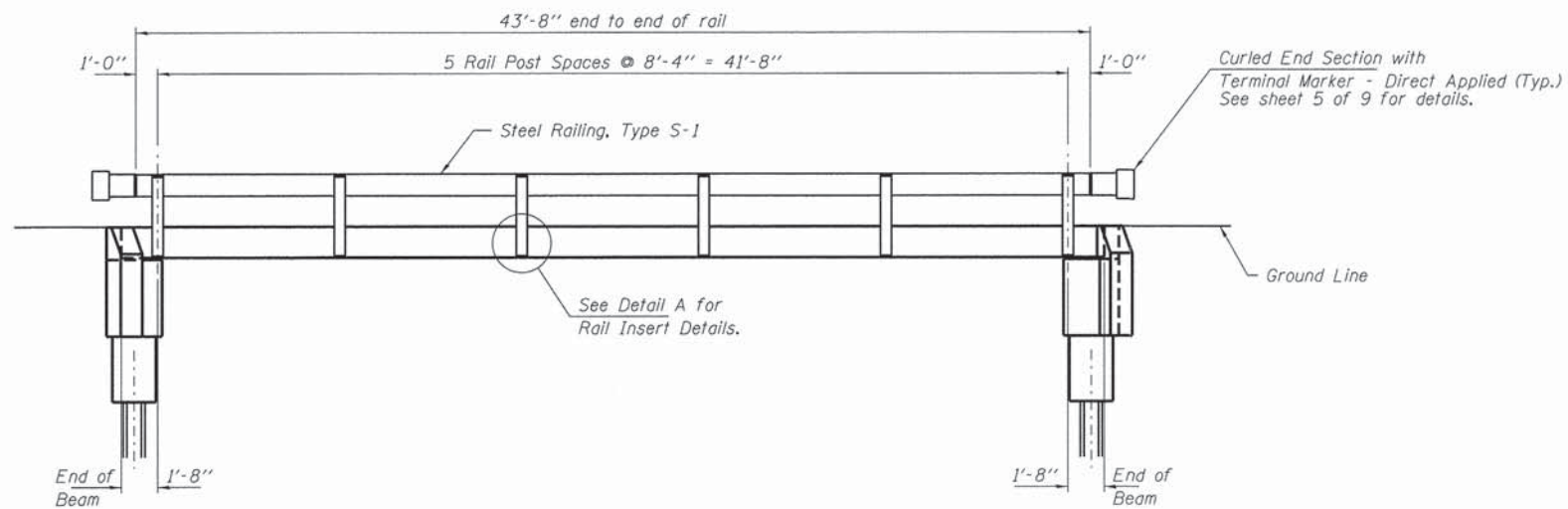

ELEVATION
 Showing Rail Post Spaces
 See sheet 5 of 9 for Railing Details.

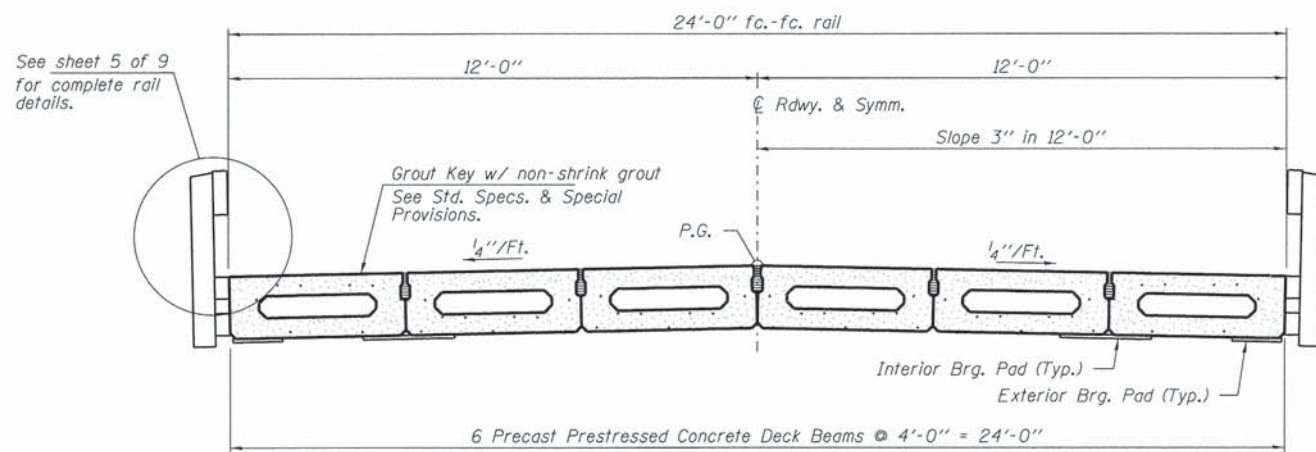

CROSS SECTION
 See sheets 2 & 3 of 9 for Superstructure.

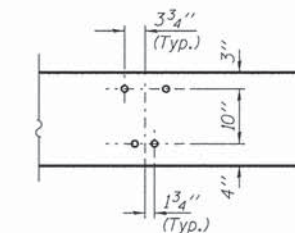

DETAIL A

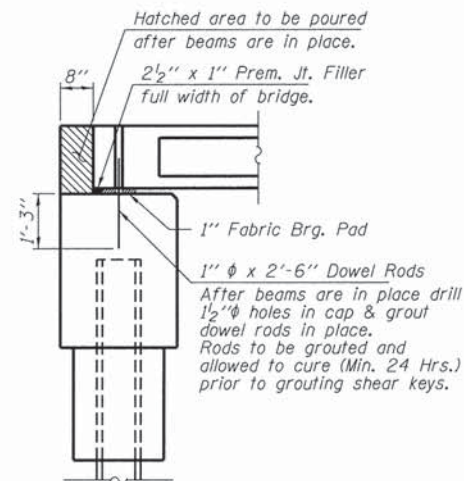

SECTION AT ABUTMENTS
 @ Rt. L's

FILE NAME * #FILE*	USER NAME *	DESIGNED - L.A.P.	REVISED -	STATE OF ILLINOIS WHITE COUNTY HIGHWAY DEPARTMENT	SUPERSTRUCTURE DETAILS STRUCTURE NO. 097-3269	C.H.	SECTION	COUNTY	TOTAL SHEETS	SHEET NO.	
HAMPTON, LENZINI AND RENWICK, INC. 3048 STEVENSON DRIVE, SUITE 201 SPRINGFIELD, ILLINOIS 62703	PLOT SCALE *	CHECKED - S.W.M.	REVISED -			13	09-00115-00-BR	WHITE	15	10	
ILLINOIS PROFESSIONAL DESIGN FIRM L1 / PE / SE CORP. 184-000959	PLOT DATE * #DATE*	DRAWN - R.D.H.	REVISED -			CONTRACT NO. 99513					
		CHECKED - D.A.B.	REVISED -			ILLINOIS FED. AID PROJECT					

SHEET NO. 4 OF 9 SHEETS

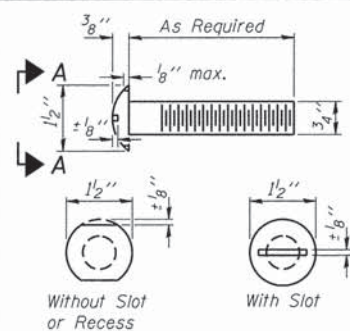

**VIEW A-A
ROUND HEAD BOLT**

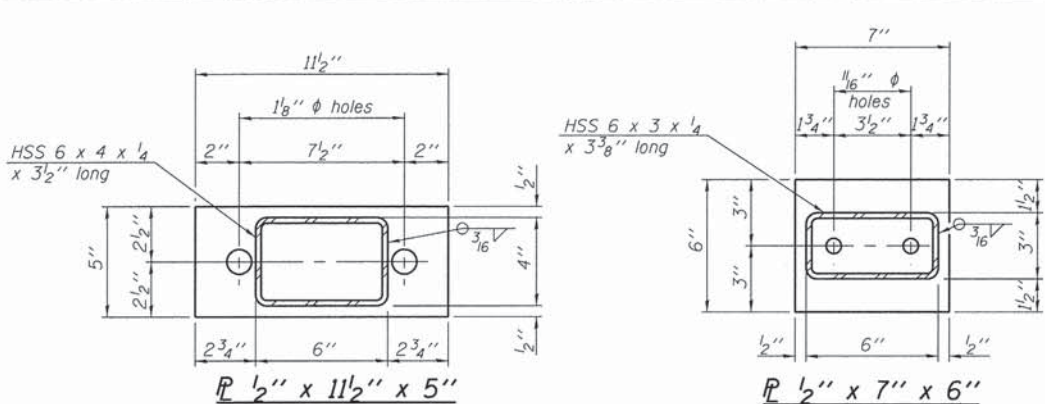

Note: Cost of curled end sections shall be included with the Steel Railing. (4 Required)

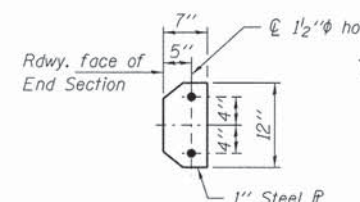

SECTION E-E

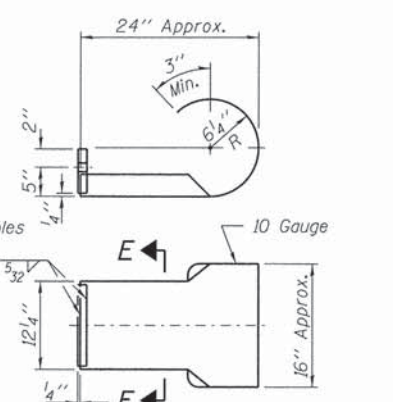

CURLED END SECTION DETAILS

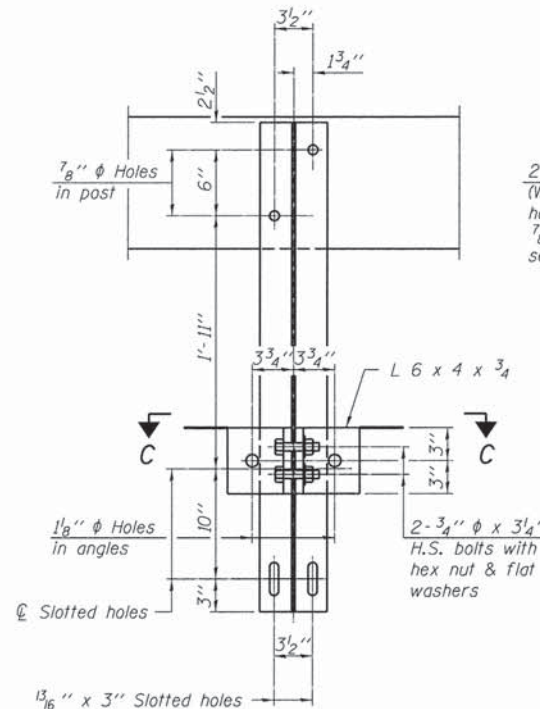

SECTION B-B

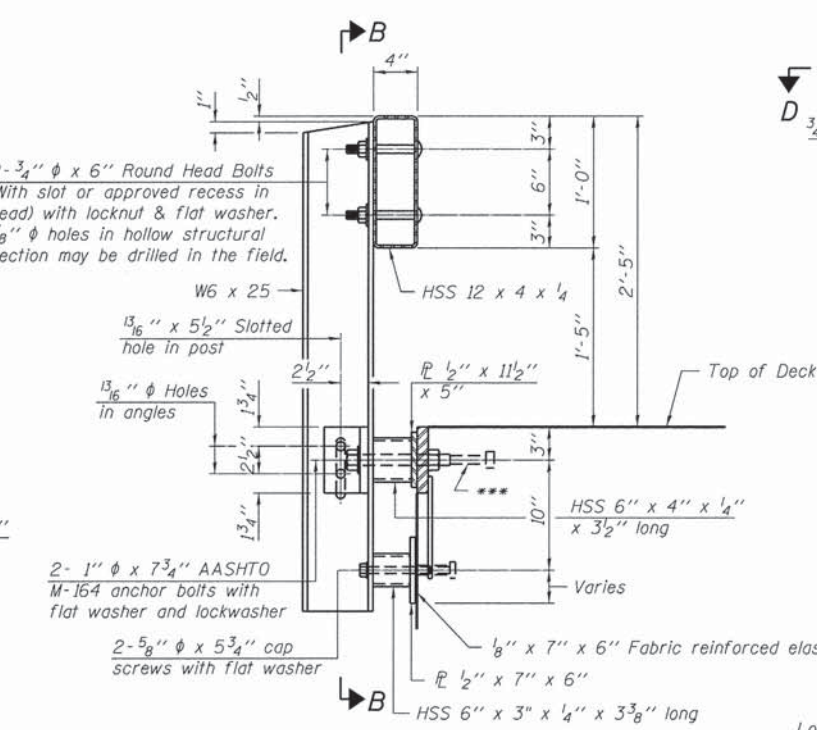

SECTION AT RAILING POST

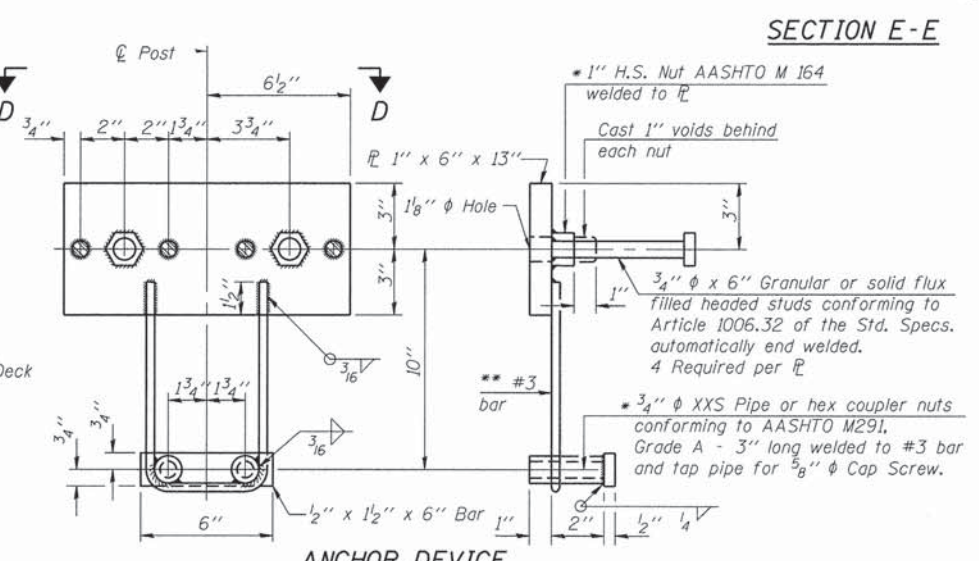

ANCHOR DEVICE

Notes:
All field drilled holes shall be coated with an approved zinc rich paint before erection.
For multi-span bridges, sufficient 1/4 inch x 6 inch x 1-2 inch galvanized steel shims shall be provided to align rail between adjacent spans. Cost included with Steel Railing, Type S-1.
All steel rail elements shall be galvanized according to Article 509.05 of the Standard Specifications.
*** The studs of the anchor devices shall be placed below the top reinforcement bars and the outermost longitudinal reinforcement bar shall be placed directly above the studs of the rail post anchor device.

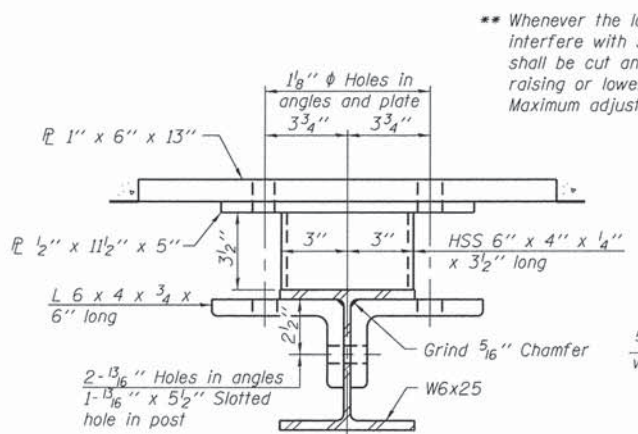

SECTION C-C

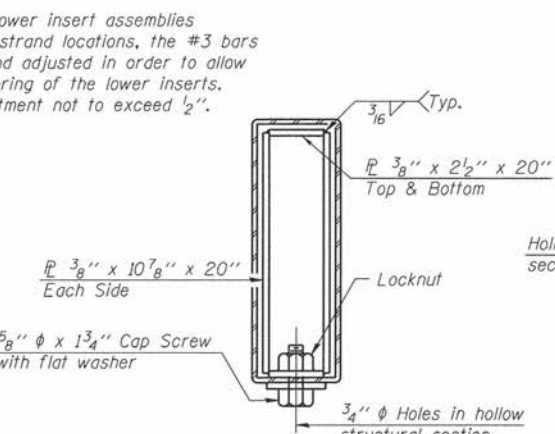

SECTIONS AT RAIL SPLICE

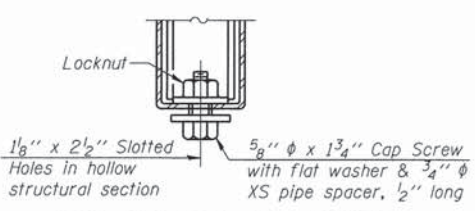

RAIL SPLICE CONNECTION AT EXPANSION JT.

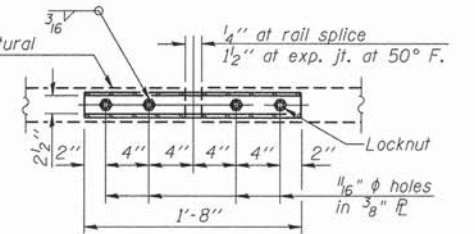

PLAN-BOTT. SPLICE AT TYPICAL

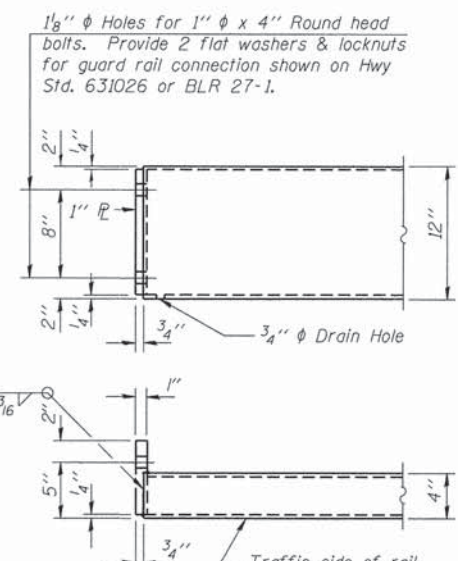

END OF RAIL DETAILS

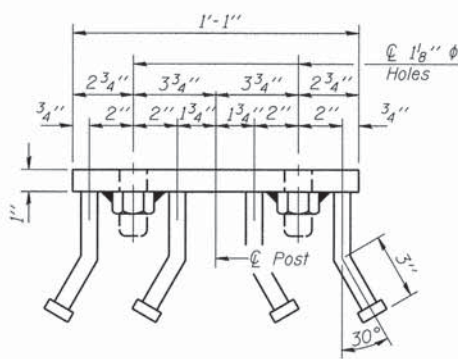

VIEW D-D

BILL OF MATERIAL

Item	Unit	Quantity
Steel Railing, Type S-1	Foot	88

R-23A 7-1-10 (10'-9" Maximum Post Spacing)

FILE NAME = #FILE#	USER NAME =	DESIGNED - L.A.P.	REVISED -
HAMPTON, LENZINI AND RENWICK, INC.		CHECKED - S.W.M.	REVISED -
3845 STEVENSON DRIVE, SUITE 201		DRAWN - R.D.H.	REVISED -
SPRINGFIELD, ILLINOIS 62761		CHECKED - D.A.B.	REVISED -
ILLINOIS PROFESSIONAL DESIGN FIRM			
LSI/P&E/SS CORP. 184.000028			

STATE OF ILLINOIS
WHITE COUNTY HIGHWAY DEPARTMENT

STEEL RAILING, TYPE S-1
STRUCTURE NO. 097-3269

SHEET NO. 5 OF 9 SHEETS

C.H.	SECTION	COUNTY	TOTAL SHEETS	SHEET NO.
13	09-00115-00-BR	WHITE	15	11
				CONTRACT NO. 99513
ILLINOIS FED. AID PROJECT				

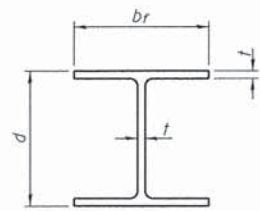

STEEL PILE TABLE

Designation	Depth d	Flange width br	Web and Flange thickness t	Encasement diameter A
HP 14x117	14 1/4"	14 7/8"	13/16"	30"
x102	14"	14 3/4"	1/16"	30"
x89	13 7/8"	14 3/4"	5/8"	30"
x73	13 5/8"	14 5/8"	1/2"	30"
HP 12x84	12 1/4"	12 1/4"	1/16"	24"
x74	12 9/8"	12 1/4"	5/8"	24"
x63	12"	12 9/8"	1/2"	24"
x53	11 3/4"	12"	7/16"	24"
HP 10x57	10"	10 1/4"	9/16"	24"
x42	9 3/4"	10 9/8"	7/16"	24"
HP 8x36	8"	8 1/8"	7/16"	18"

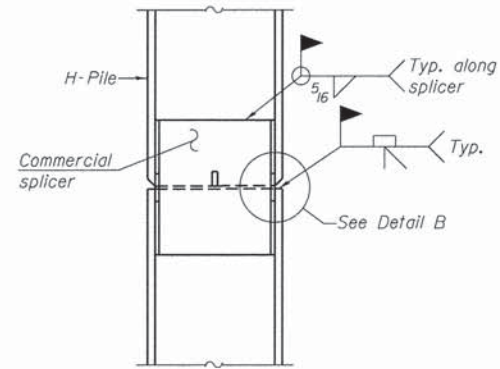

ELEVATION

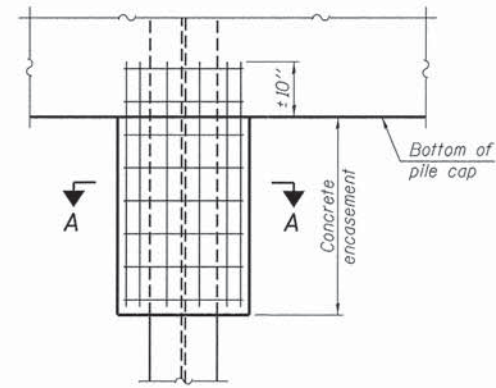

ELEVATION

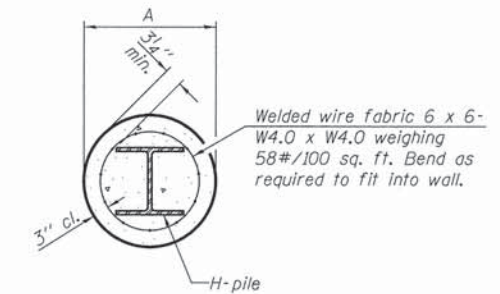

SECTION A-A

Note:
Forms for encasement may be omitted when soil conditions permit.

PILE ENCASUREMENT

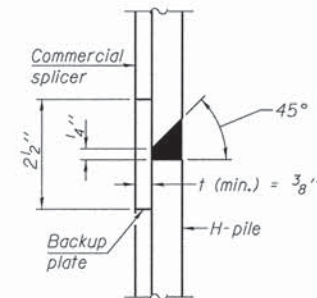

DETAIL "B"

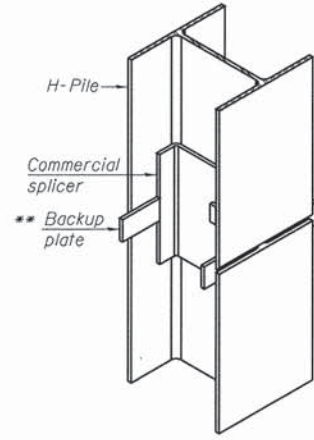

ISOMETRIC VIEW

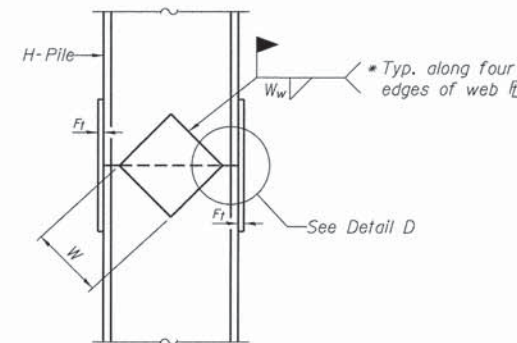

ELEVATION

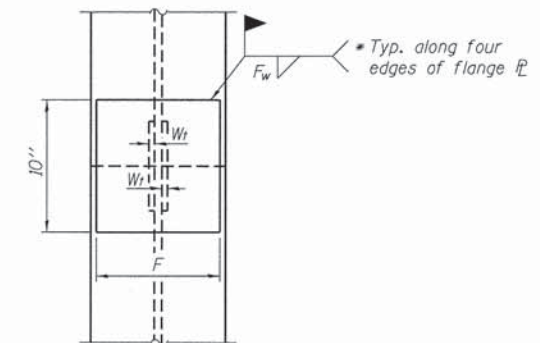

END VIEW

WELDED COMMERCIAL SPLICE

WELDED PLATE FIELD SPLICE

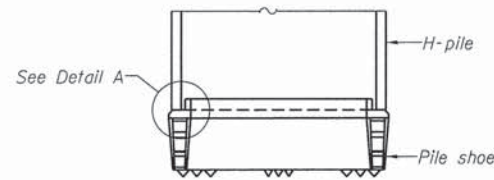

ELEVATION

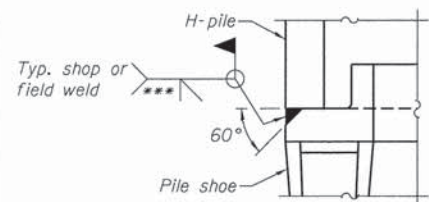

DETAIL A

H-PILE SHOE ATTACHMENT

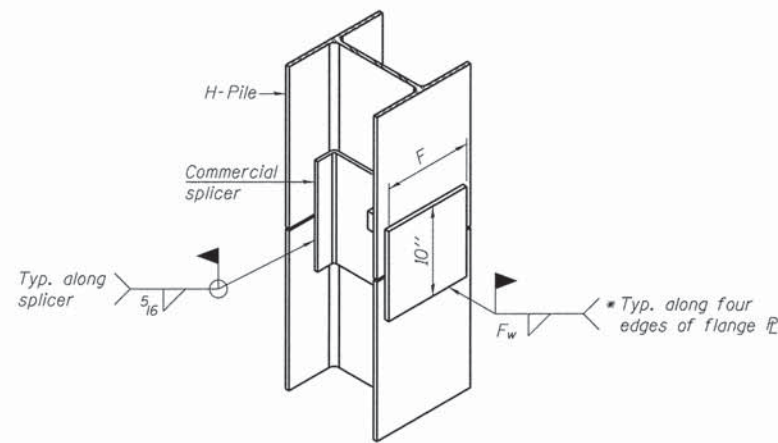

ISOMETRIC VIEW

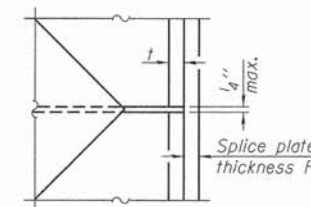

DETAIL D

WELDED COMMERCIAL SPLICE ALTERNATE

- * Interrupt welds 1/4" from end of web and/or each flange.
- ** Remove portions of backup plates that extend outside the flanges.
- *** Weld size per pile shoe manufacturer (5/16" min.).

Note:
The steel H-piles shall be according to AASHTO M270 Grade 50.

Designation	F	Ft	Fw	W	Wt	Ww
HP 14x117	12 1/2"	1"	7/8"	7 3/4"	5/8"	1/2"
x102	12 1/2"	7/8"	3/4"	7 3/4"	5/8"	1/2"
x89	12 1/2"	3/4"	1/16"	7 3/4"	5/8"	1/2"
x73	12 1/2"	5/8"	9/16"	7 3/4"	5/8"	1/2"
HP 12x84	10"	7/8"	1/16"	6 1/2"	5/8"	1/2"
x74	10"	7/8"	1/16"	6 1/2"	5/8"	1/2"
x63	10"	5/8"	1/2"	6 1/2"	1/2"	3/8"
x53	10"	5/8"	1/2"	6 1/2"	1/2"	3/8"
HP 10x57	8"	3/4"	9/16"	5 1/4"	1/2"	3/8"
x42	8"	5/8"	9/16"	5 1/4"	1/2"	3/8"
HP 8x36	7"	5/8"	7/16"	4 1/4"	1/2"	3/8"

F-HP

1-27-12

FILE NAME = #FILE#	USER NAME =	DESIGNED - L.A.P.	REVISED -	STATE OF ILLINOIS WHITE COUNTY HIGHWAY DEPARTMENT	HP PILE DETAILS STRUCTURE NO. 097-3269	C.H.	SECTION	COUNTY	TOTAL SHEETS	SHEET NO.	
HAMPTON, LENZINI AND RENWICK, INC. 3945 STEVENSON DRIVE, SUITE 201 SPRINGFIELD, ILLINOIS 62761	PLLOT SCALE =	CHECKED - S.W.M.	REVISED -			13	09-00115-00-BR	WHITE	15	13	
ILLINOIS PROFESSIONAL DESIGN FIRM L.S. / P.E. / S.E. CORP. 184-000099	PLLOT DATE = #DATE#	DRAWN - R.D.H.	REVISED -			CONTRACT NO. 99513					
		CHECKED - D.A.B.	REVISED -			ILLINOIS FED. AID PROJECT					

SHEET NO. 7 OF 9 SHEETS

Bridge Foundation Boring Log

Project: H-09057 Bridge over Limekiln Creek Date: 3/9/09
Section: 09-00115-00-BR Station _____ Bored by: D. Russell
Structure: _____ Checked By: J. Holcomb
County: White

Boring No. <u>2</u> Station: _____ Offset: _____	Elevation	N	Qu	tsf	w	Surface Water Elev.		Elevation	N	Qu	tsf	w
						During Drilling	Upon Completion					
Ground Surface	389.5	0										
5" Crushed Stone	389.0											
Brown Mottled Gray Sandy CLAY (A-6)		5		7					7	0.65	29	
	385.5											
Gray Mottled Brown Silty CLAY (A-6) with sand		3	1.38	26					6	0.88	24	
	383.0											
Gray Mottled Brown CLAY (A-6)		6	1.18	26					10	1.78	18	
	380.5											
Brown Mottled Gray CLAY (A-6)		7	1.75	24								
	378.0											
Gray Mottled Brown CLAY (A-6) with sand		9	2.18	25					16	3.08	15	
	373.0											
Gray CLAY (A-6) with sand		4	0.88	20					8		23	
	368.0											
Gray Mottled Brown CLAY (A-6)		4	2.25	24								

N = Standard Penetration Test Blows per foot to drive 2" O.D. Split Spoon Sampler 12" with a 140 lbs. hammer falling 30"
Qu - Unconfined Compressive Strength in tons/sq.ft.
w - Water Content - percentage of oven dry weight-%
B = Bulge Failure
S = Shear Failure
E = Estimated Value
P = Penetrometer

Bridge Foundation Boring Log

Project: H-09057 Bridge over Limekiln Creek Date: 3/9/09
Section: 09-00115-00-BR Station _____ Bored by: D. Russell
Structure: _____ Checked By: J. Holcomb
County: White

Boring No. <u>2</u> Station: _____ Offset: _____	Elevation	N	Qu	tsf	w	Surface Water Elev.		Elevation	N	Qu	tsf	w
						During Drilling	Upon Completion					
silt (continued)	45	15		26								
	320.5											
Brown Mottled Gray SHALE		47	5.05	10								
	341.0											
Gray LIMESTONE		100		9								
	315.5											
Gray SHALE		100		13								
	335.5											
Gray Sandy CLAY (A-6)		71	2.65	22								
	310.5											
End of Boring @ -79.0'												
	325.5											
Gray Mottled Brown Sandy CLAY (A-6)		100		19								

N = Standard Penetration Test Blows per foot to drive 2" O.D. Split Spoon Sampler 12" with a 140 lbs. hammer falling 30"
Qu - Unconfined Compressive Strength in tons/sq.ft.
w - Water Content - percentage of oven dry weight-%
B = Bulge Failure
S = Shear Failure
E = Estimated Value
P = Penetrometer

BORING-2