

ROUTE	SECTION	COUNTY	TOTAL SHEETS	SHEET NO.
TR 3	10-01163-00-BR	ALEXANDER	12	11
PROJECT NO. BROS-003(125)			CONTRACT NO. 99521	

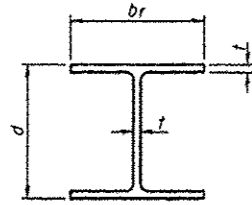

**STEEL PILE TABLE**

Designation	Depth d	Flange width br	Web and Flange thickness t	Encasement diameter A	Encasement Quantity/Ft. C.Y.
HP 14x117	14 1/4"	14 7/8"	13/16"	30"	0.173
x102	14"	14 3/4"	1/8"	30"	0.174
x89	13 7/8"	14 3/4"	5/8"	30"	0.175
x73	13 5/8"	14 5/8"	1/2"	30"	0.176
HP 12x84	12 1/4"	12 1/4"	1/8"	24"	0.110
x74	12 1/2"	12 1/4"	5/8"	24"	0.111
x63	12"	12 1/8"	1/2"	24"	0.112
x53	11 3/4"	12"	7/16"	24"	0.112
HP 10x57	10"	10 1/4"	9/16"	24"	0.112
x42	9 3/4"	10 1/8"	7/16"	24"	0.113
HP 8x36	8"	8 1/2"	7/16"	18"	0.063

Note: The steel H-piles shall be according to AASHTO M270 Grade 50.

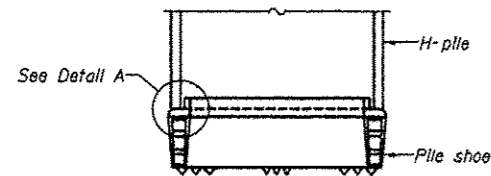

**ELEVATION**

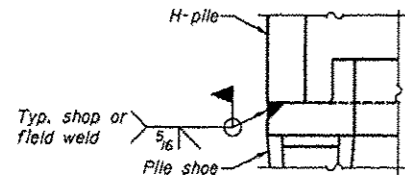

**DETAIL A**

**H-PILE SHOE ATTACHMENT**

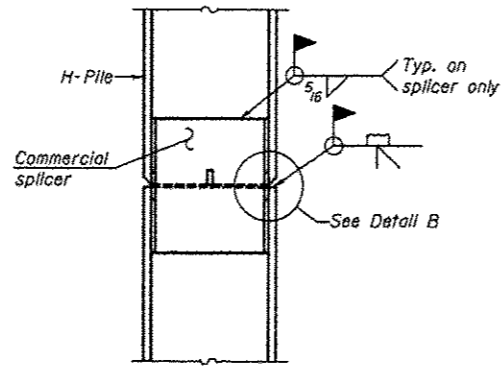

**ELEVATION**

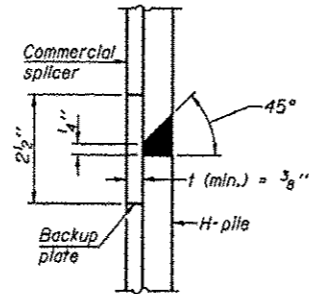

**DETAIL "B"**

**WELDED COMMERCIAL SPLICE**

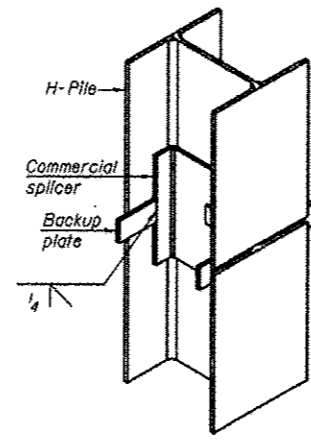

**ISOMETRIC VIEW**

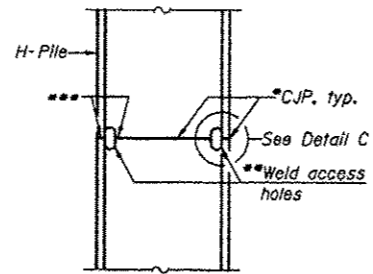

**ELEVATION**

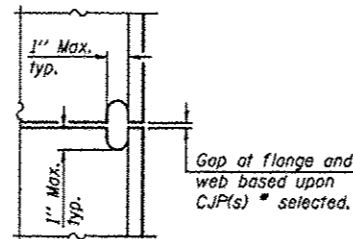

**DETAIL C**

**COMPLETE PENETRATION WELD SPLICE**

\*Use joint conforming to Figure 3.4 in AWS D1.1, Structure Welding Code - Steel.

\*\*Preparation per Fig. 5.2 in AWS D1.1, Structure Welding Code - Steel.

\*\*\*Interrupt welds 1/4" from end of each pile.

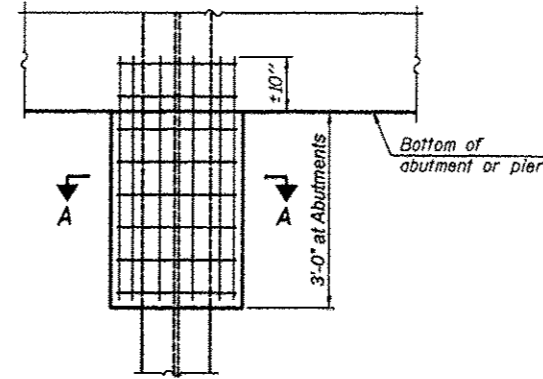

**ELEVATION**

**PILE ENCASEMENT**

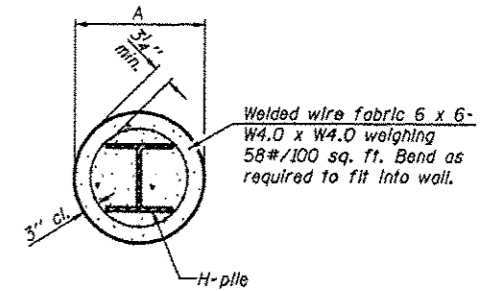

**SECTION A-A**

Note: Forms for encasement may be omitted when soil conditions permit.

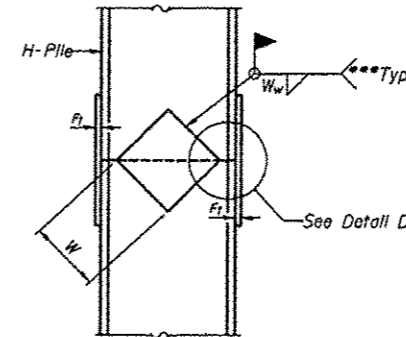

**ELEVATION**

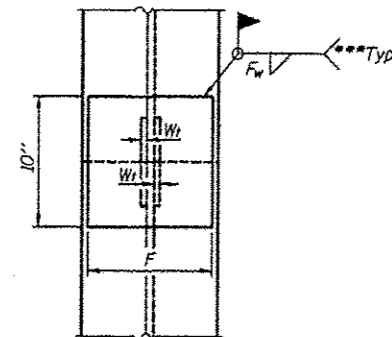

**END VIEW**

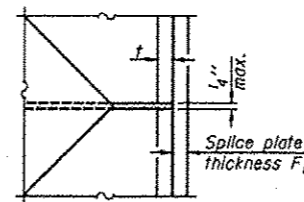

**DETAIL D**

**WELDED PLATE FIELD SPLICE**

Designation	F	F <sub>t</sub>	F <sub>w</sub>	W	W <sub>t</sub>	W <sub>w</sub>
HP 14x117	12 1/2"	1"	7/8"	7 3/4"	5 1/2"	1/2"
x102	12 1/2"	7/8"	3/4"	7 3/4"	5 1/2"	1/2"
x89	12 1/2"	3/4"	1/8"	7 3/4"	5 1/2"	1/2"
x73	12 1/2"	5/8"	9/16"	7 3/4"	5 1/2"	1/2"
HP 12x84	10"	7/8"	1/8"	6 1/2"	5 1/2"	1/2"
x74	10"	7/8"	1/8"	6 1/2"	5 1/2"	1/2"
x63	10"	5/8"	1/2"	6 1/2"	1/2"	3/8"
x53	10"	5/8"	1/2"	6 1/2"	1/2"	3/8"
HP 10x57	8"	3/4"	9/16"	5 1/4"	1/2"	3/8"
x42	8"	5/8"	9/16"	5 1/4"	1/2"	3/8"
HP 8x36	7"	5/8"	7/16"	4 1/4"	1/2"	3/8"

**PILING DETAILS**  
**TOWNSHIP ROUTE 3 (COUNTY LINE ROAD)**  
**TRIBUTARY TO COOPER CREEK**  
**SECTION 10-01163-00-BR**  
**ALEXANDER COUNTY**  
**STRUCTURE NO. 002-3111**