

EXISTING TYPICAL SECTION
STA. 12+82.51 TO STA. 20+80.00

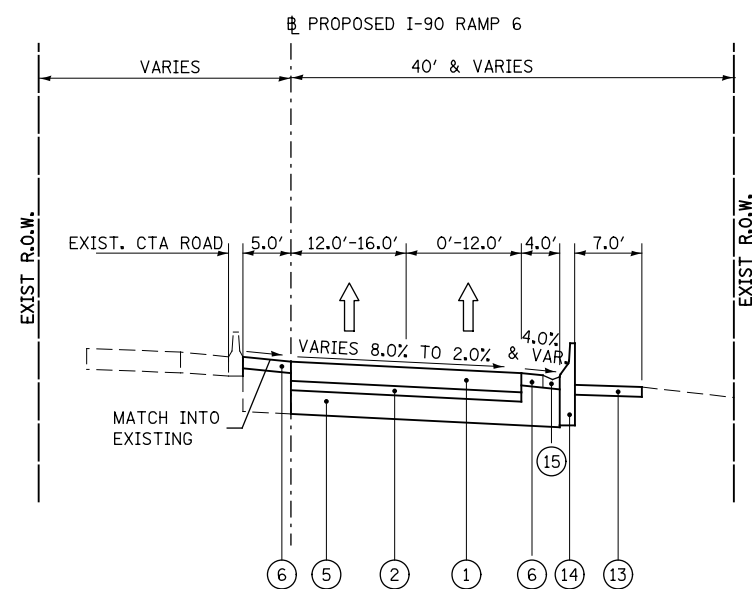

PROPOSED TYPICAL SECTION
STA. 12+82.51 TO STA. 20+80.00

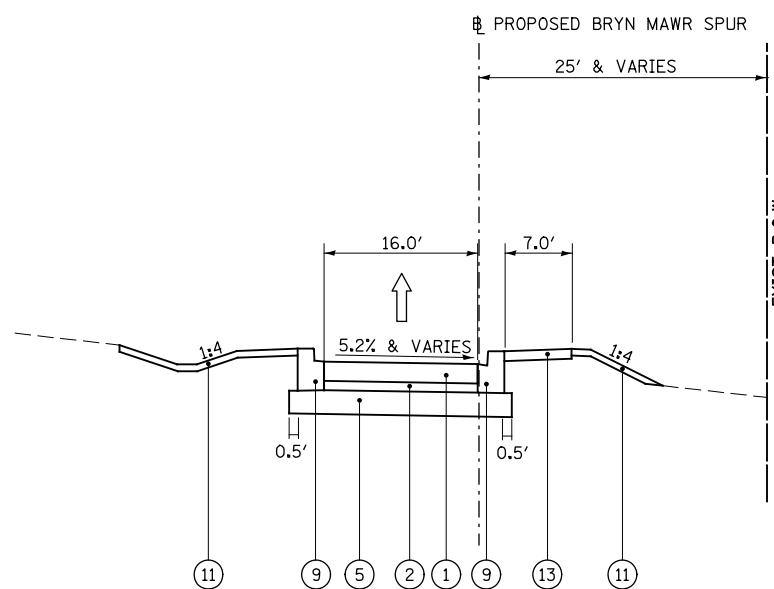

PROPOSED TYPICAL SECTION
STA. 1+00.00 TO STA. 4+50.00

EXISTING LEGEND

- (A) HMA OVERLAY, 4"±
- (B) P.C.C. PAVEMENT, 9"±
- (C) COMBINATION CONCRETE CURB AND GUTTER TYPE B-6.24
- (D) CONCRETE MEDIAN
- (E) P.C.C. SIDEWALK, 5"
- (F) CONCRETE RETAINING WALL
- (G) PAVED SHOULDER
- (H) AGGREGATE SUBGRADE, 12"

REMOVAL LEGEND

- (a) PAVEMENT REMOVAL
- (b) HOT-MIX ASPHALT REMOVAL, 2-1/2"
- (c) COMBINATION CURB AND GUTTER REMOVAL
- (d) MEDIAN REMOVAL
- (e) PAVED SHOULDER REMOVAL
- (f) SIDEWALK REMOVAL

PROPOSED LEGEND

- (1) PORTLAND CEMENT CONCRETE PAVEMENT, 9 1/2" (JOINTED)
- (2) STABILIZED SUBBASE HOT-MIX ASPHALT, 4 1/2"
- (3) POLYMERIZED HOT-MIX ASPHALT SURFACE COURSE, MIX "F", N90, 1 3/4"
- (4) POLYMERIZED LEVELING BINDER (MACHINE METHOD), IL-4.75, N50, 3/4"
- (5) AGGREGATE SUBGRADE IMPROVEMENT, 12" (THICKNESS VARIES UNDER SHOULDER)
- (6) HOT MIX ASPHALT SHOULDERS, 6"
- (7) CONCRETE MEDIAN, TYPE SB-6.12
- (8) COMBINATION CONCRETE CURB AND GUTTER, TYPE B-6.12
- (9) COMBINATION CONCRETE CURB AND GUTTER, TYPE B-6.24
- (10) PORTLAND CEMENT CONCRETE BASE COURSE, 9 1/2"
- (11) TOPSOIL FURNISH AND PLACE, 4" EROSION CONTROL BLANKET (SEE LANDSCAPING PLAN)
- (12) CONCRETE MEDIAN SURFACE, 4"
- (13) PORTLAND CEMENT CONCRETE SIDEWALK, 5"
- (14) CONCRETE RETAINING WALL (SEE STRUCTURAL PLAN)
- (15) CONCRETE GUTTER, TYPE B