

GENERAL NOTES

SPECIFICATIONS:

DESIGN: AASHTO Standard Specifications for Structural Supports for Highway Signs, Luminaires and Traffic Signals. ("AASHTO Specifications") (2)

CONSTRUCTION: Current (at time of letting) Illinois Department of Transportation Standard Specifications for Road and Bridge Construction, Supplemental Specifications and Special Provisions. ("Standard Specifications")

LOADING: 90 M.P.H. WIND VELOCITY

WALKWAY LOADING: Dead load plus 500 lbs. concentrated live load.

MINIMUM CLEARANCE: 3" greater than bridge members at all locations. (All Obstructions)

WELDING: All welds to be continuous unless otherwise shown. All welding to be done in accordance with current AWS D1.1 Structural Welding Code (Steel) and the Standard Specifications.

MATERIALS: All Structural Steel Pipe shall be ASTM A53 Grade B with a minimum yield of 35,000 p.s.i., or A500 Grade B or C with a minimum yield of 46,000 p.s.i. If A500 pipe is substituted for A53, then the outside diameter shall be as detailed and wall thickness greater than or equal to A53.

All Structural Steel Plates and Shapes shall conform to AASHTO M270 Gr. 36, Gr. 50 (M183, M223 Gr. 50.).

HIGH STRENGTH BOLTS: All bolts, washers, nuts and locknuts shall satisfy the requirements of ASTM designation A307 unless noted as "H.S." which shall require AASHTO M164 (A325), ASTM A449, or approved alternate. All fasteners shall be hot dip galvanized per AASHTO M232 unless otherwise specified.

GALVANIZING: All Steel Grating, Plates, Shapes and Pipe shall be Hot Dip Galvanized after fabrication in accordance with AASHTO M111. Painting is not permitted.

ANCHOR RODS: All-threaded rod shall conform to ASTM F1554 Grade 105, 3/4" ϕ x 12" long, each with one plate washer and locknut and be hot dip galvanized per AASHTO M232. They shall be either cast into the concrete or epoxy grouted in accordance with Section 584 of the Standard Specifications. Minimum embedment in concrete shall be 9".

(1) Bracket spacing $g \leq 6'-0"$, max. Spacing shall be uniform if possible but may vary $\pm 6"$ to miss existing obstruction (rail post, light poles, web stiffeners, splice plates, etc.). Adjust bracket lengths accordingly on skewed structures.

(2) Any design modifications shall be based on the current version of applicable specifications and submitted for the Engineer's approval.

(3) Unit price includes brackets, supports, anchor bolts, fasteners, fabrication, delivery, erection, field drilling and other necessary items. Limits of payment are based on sign panel length (c_s , d_{s1} , d_{s2}).

(4) Walkway and lighting not required. Use alternate brackets without walkway supports.

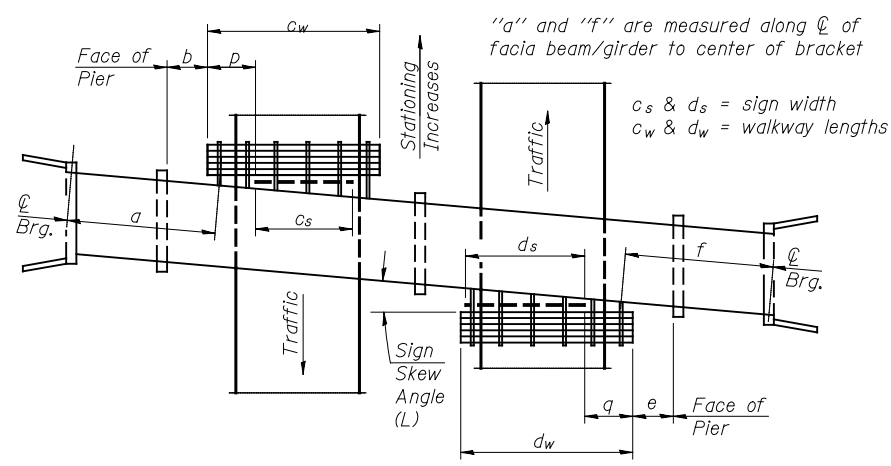

PLAN
(Left Sign Skew > 15°)
WALKWAY AND HANDRAIL SKETCH
(Road plan beneath structure varies.)

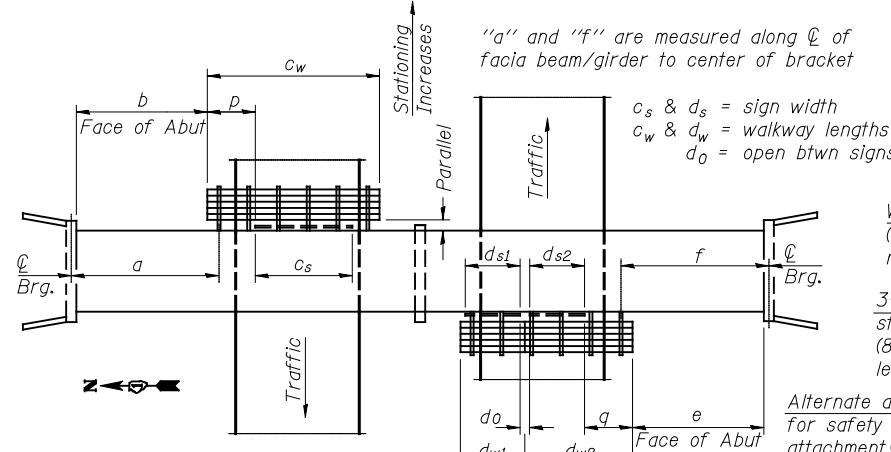

PLAN
(For Sign Skew $\leq 15^\circ$, all brackets constant)
WALKWAY AND HANDRAIL SKETCH
(Road plan beneath structure varies.)

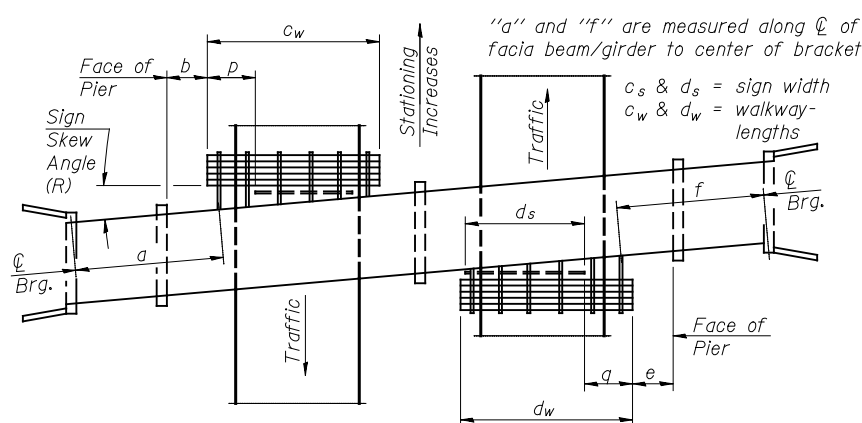

PLAN
(Right Sign Skew > 15°)
WALKWAY AND HANDRAIL SKETCH
(Road plan beneath structure varies.)

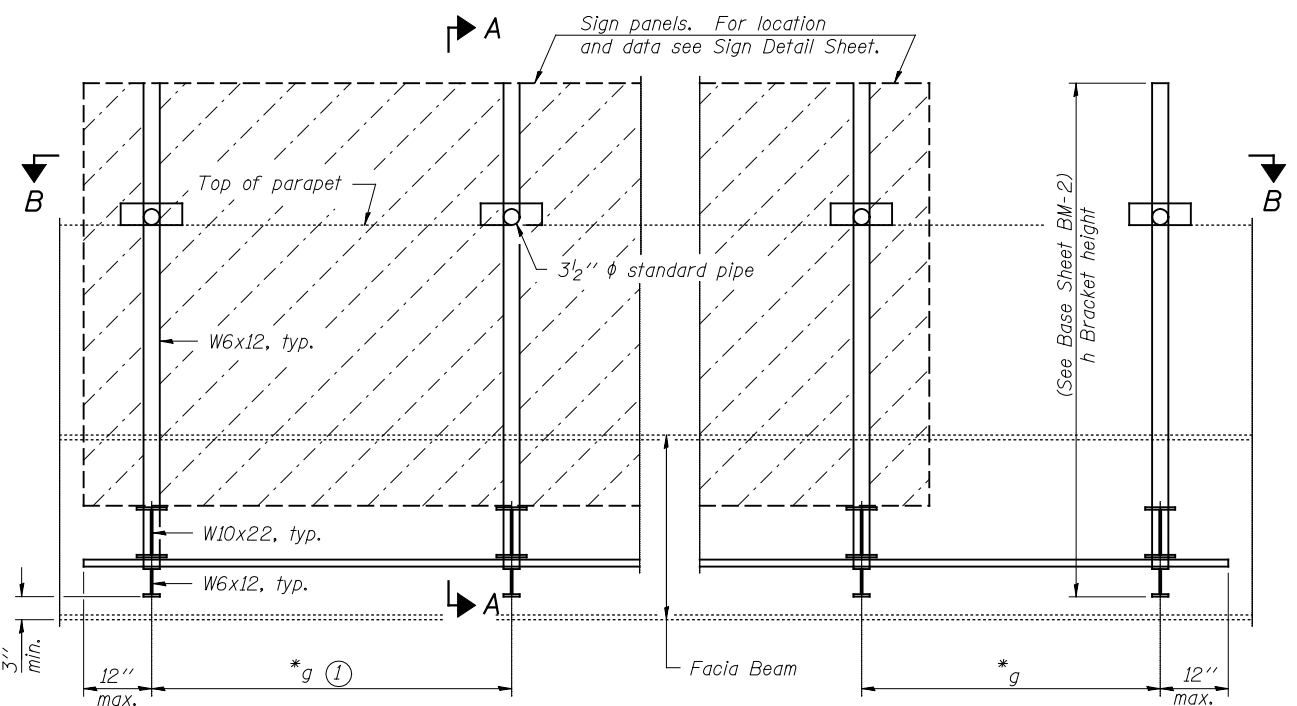

TYPICAL FRONT ELEVATION
(With lights, safety chain and handrail omitted for clarity.)

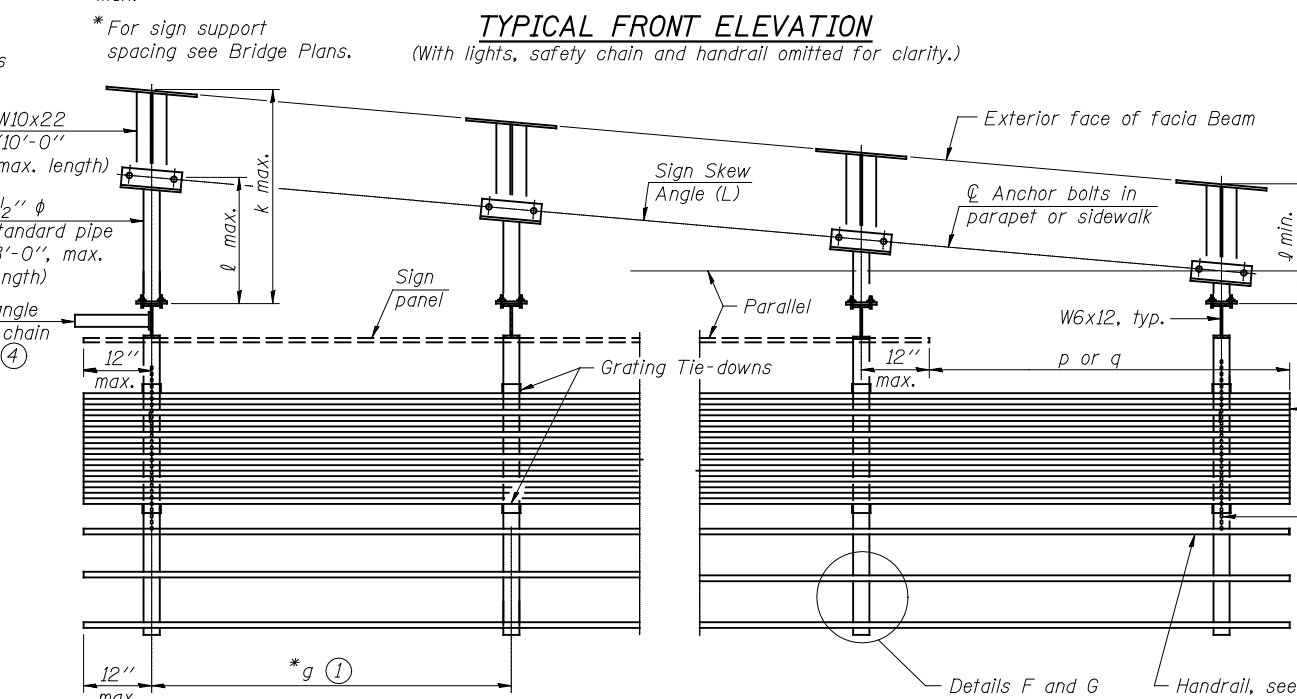

SECTION B-B
(Shown: Left Sign Skew > 15°)

TOTAL BILL OF MATERIAL

(3) OVERHEAD SIGN STRUCTURE - BRIDGE MOUNTED	Foot	62.0
--	------	------

Structure Number	Sign Skew Angle (L) or (R)	Bridge Station	Bridge Structure Number	Contract Route Designation	a	b	c _s	c _w	d ₀	d _{s1}	d _{s2}	d _{w1}	d _{w2}	e	f	No. of Brackets (Total)	p	q	Total Grating/Hndrl. Lengths (c _w + d _w)
1B0161090R064.1	3° L	3383+30	016-1250	2746	—	—	—	—	4'-6"	16'-0"	21'-6"	—	—	—	43'-11 ⁵ / ₈ "	9	—	—	—
1B0161090L064.1	3° L	3383+30	016-1250	2746	64'-11 ³ / ₄ "	—	24'-6"	—	—	—	—	—	—	—	—	5	—	—	—

Dimensions a, b, e, f & g may vary as approved by the Engineer, see (1).
When c_w < c_s and/or d_w < d_s, use alternate brackets without walkway supports where applicable, see (3).

BM-1

6-1-12

PATRICK ENGINEERING INC.
4870 VARSITY DRIVE
LISLE, IL 60532
patrickengineering.com

DESIGNED - RLD	REVISIONS
DRAWN - CPK	REVISIONS
CHECKED - JAH	REVISIONS
DATE - 2/18/2013	REVISIONS

STATE OF ILLINOIS
DEPARTMENT OF TRANSPORTATION

BRIDGE MOUNTED SIGN STRUCTURE
GENERAL PLAN AND ELEVATION

F.A.U. RTE.	SECTION	COUNTY	TOTAL SHEETS	SHEET NO.
2746	1616B	COOK	404	152
CONTRACT NO. 60J14				
ILLINOIS FED. AID PROJECT				