

s:\projects\3009 1-90\_cumberland-patrick\project work\disciplines\electrical\sheet\DI60J14-sht-light.13.dgn

2/18/2013 2:43:37 PM

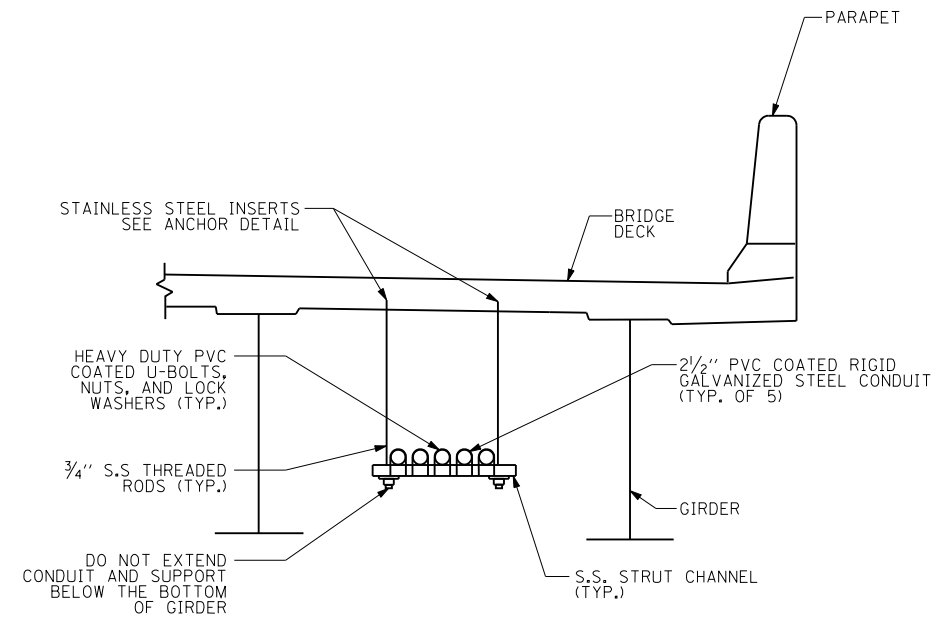

**TYPICAL CONDUIT SUPPORT ATTACHED TO BRIDGE DECK**  
NOT TO SCALE

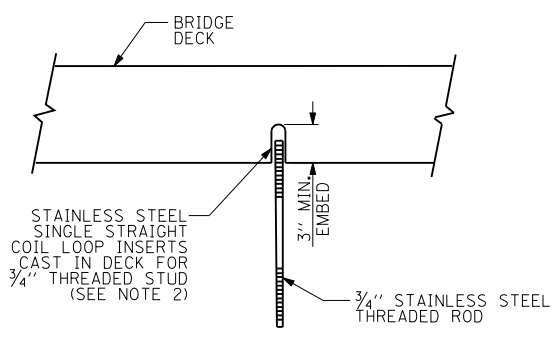

**THREADED ROD INSTALLATION**  
NOT TO SCALE

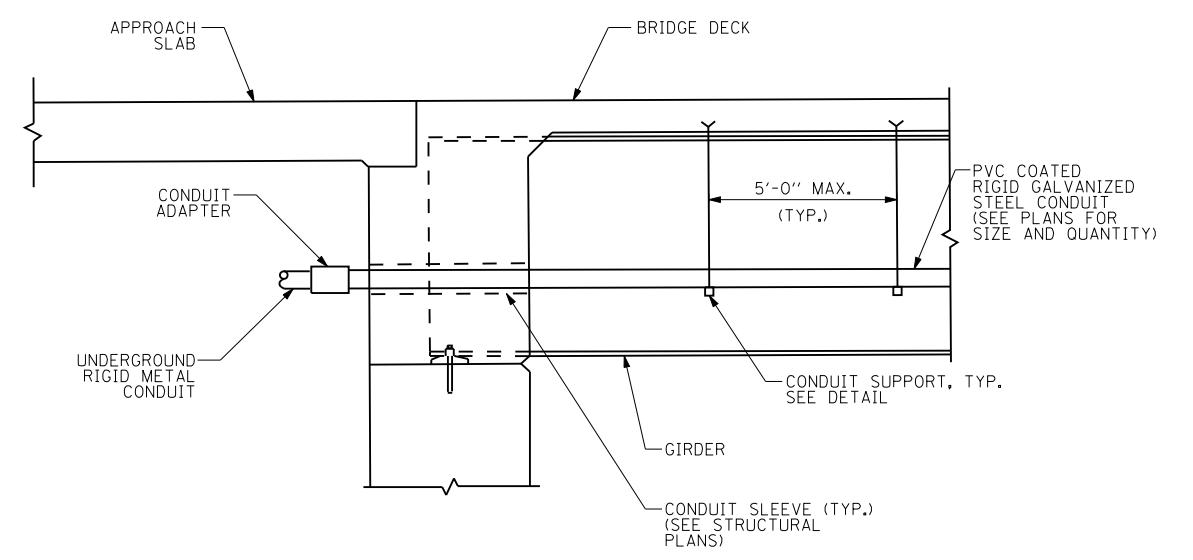

**TYPICAL CONDUIT INSTALLATION THROUGH INTEGRAL ABUTMENT**  
NOT TO SCALE

**NOTES:**  
1. ALL COMPONENTS OF THE CONDUIT SUPPORT SYSTEM ARE INCLUDED IN THE COST OF THE CONDUIT ATTACHED TO STRUCTURE.

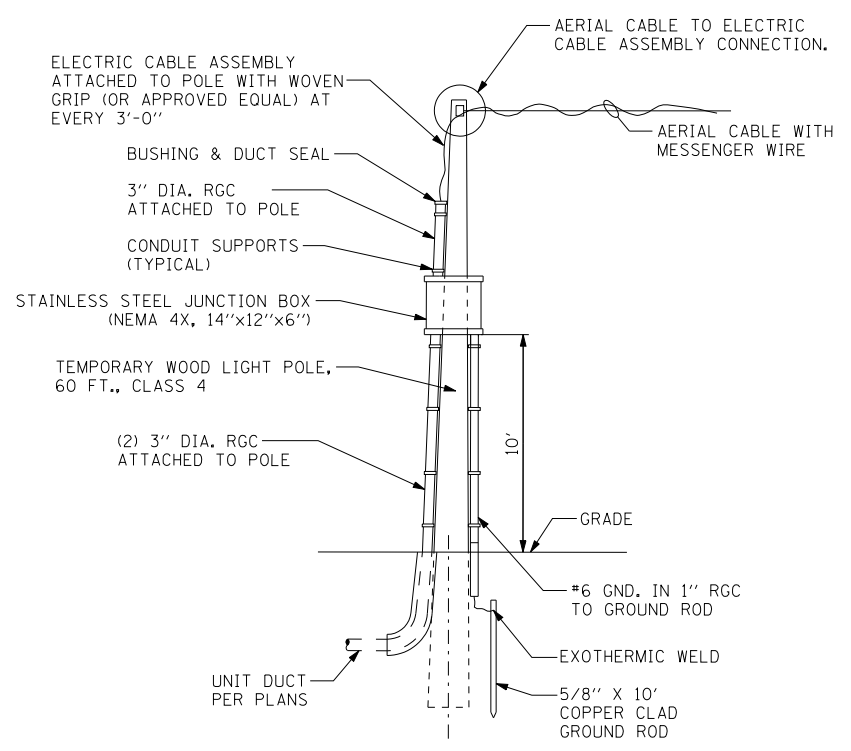

**AERIAL CABLE TO UNDERGROUND DUCT TRANSITION DETAIL**  
NOT TO SCALE

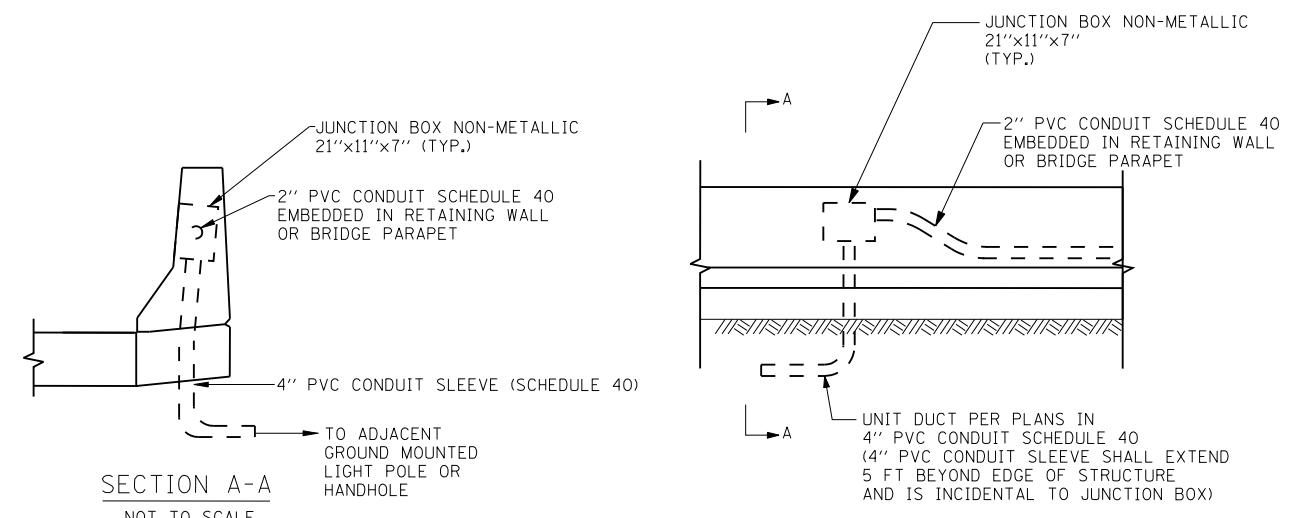

**SECTION A-A**  
NOT TO SCALE  
**UNDERGROUND TO EMBEDDED CONDUIT TRANSITION**  
NOT TO SCALE

**NOTES:**  
1. THE JUNCTION BOX, GROUND ROD, AND ALL CONDUITS ATTACHED TO THE WOOD POLE ARE INCLUDED IN THE COST OF THE ITEM "MAINTENANCE OF LIGHTING SYSTEM."

USER NAME =	DESIGNED - RAS	REVISED -
	DRAWN - RAS	REVISED -
PLOT SCALE =	CHECKED - MKR	REVISED -
PLOT DATE =	DATE - 2/18/2013	REVISED -



**STATE OF ILLINOIS DEPARTMENT OF TRANSPORTATION**

<b>IDOT LIGHTING DETAILS</b>	
SCALE: NONE	SHEET NO. 1 OF 1 SHEETS STA. TO STA.

F.A.U. RTE.	SECTION	COUNTY	TOTAL SHEETS	SHEET NO.
2746	1616B	COOK	404	245
CONTRACT NO. 60J14				
ILLINOIS FED. AID PROJECT				

LT-13