

- NOTES:**
1. ALL DIMENSIONS ARE IN INCHES (MILLIMETERS) UNLESS OTHERWISE SHOWN.
 2. MOUNTING HEIGHT IS DEFINED AS THE DISTANCE FROM THE CENTERLINE OF THE TENON TO THE BOTTOM OF THE ANCHOR BASE.
 3. TWO PIECE SHAFT WILL BE MATCHED MARKED AND INTERCHANGEABLE BETWEEN DIFFERENT UNITS. FIELD DRILLING OF THE HOLES WILL NOT BE ALLOWED.
 4. THE LIGHT POLE WILL MEET AASHTO DESIGN CRITERIA AS SPECIFIED.
 5. THE INSTALLING CONTRACTOR WILL PROVIDE A UL LISTED GROUNDING CONNECTOR, BURNDY K2C23, T&B SP4DL OR APPROVED EQUAL.
 6. LIGHT POLES WILL NOT BE INSTALLED WITHOUT MAST ARMS AND LUMINAIRES.
 7. LIGHT POLES WILL BE SET PLUMB ON THE FOUNDATION WITHOUT THE USE OF LEVELING NUTS, WASHERS OR SHIMS.
 8. LIGHTING UNIT IDENTIFICATION NUMBERS SHALL BE INSTALLED BEFORE THE LIGHTING UNIT IS ENERGIZED.

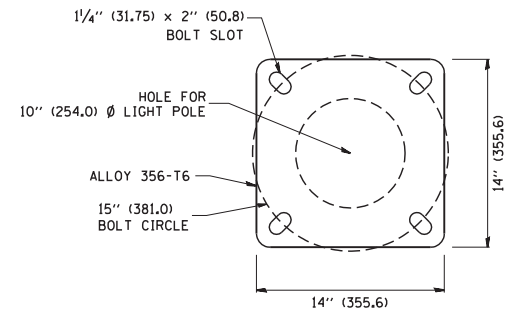

LIGHT POLE BASE PLATE DETAIL
15 INCH (381.0) BOLT CIRCLE

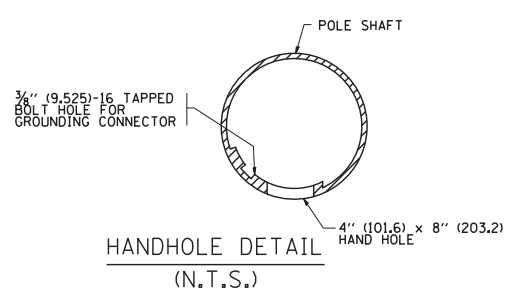

FILE NAME = W:\diststd\22x34\be400.dgn	USER NAME = gaglianobt	DESIGNED - DRAWN -	REVISED - R. TOMSONS 09-06-00 REVISED - R. TOMSONS 09-03-03
	PLOT SCALE = 50.000' / IN.	CHECKED -	REVISED -
	PLOT DATE = 1/4/2008	DATE -	REVISED -

**STATE OF ILLINOIS
DEPARTMENT OF TRANSPORTATION**

ALUMINUM LIGHT POLE			
47'-6" (14.478 m) MOUNTING HEIGHT			
SCALE: NONE	SHEET NO. 1 OF 1 SHEETS	STA.	TO STA.

F.A. RTE. 2746	SECTION 1616B	COUNTY COOK	TOTAL SHEETS 404	SHEET NO. 252
BE-400			CONTRACT NO. 60J14	
FED. ROAD DIST. NO. 1 ILLINOIS FED. AID PROJECT				