

**LOOP SPLICING REQUIREMENTS**

MINIMUM 1" (25 mm) HEAT SHRINK TUBING OVERLAP ON WIRE, PVC & SHIELDED CABLE TO FORM WATER TIGHT SEAL

WIDTH (W)	WIDTH (S)
12' (3.7 m)	8' (2.5 m)
13' (4.0 m)	9' (2.8 m)
14' (4.3 m)	10' (3.1 m)
15' (4.6 m)	11' (3.4 m)
16' (4.9 m)	12' (3.7 m)
17' (5.2 m)	13' (4.0 m)
18' (5.5 m)	14' (4.3 m)
19' (5.8 m)	15' (4.6 m)
20' (6.1 m)	18' (4.9 m)
21' (6.4 m)	17' (5.2 m)
22' (6.7 m)	18' (5.5 m)
23' (7.0 m)	19' (5.8 m)
24' (7.3 m)	20' (6.1 m)
25' (7.6 m)	21' (6.4 m)

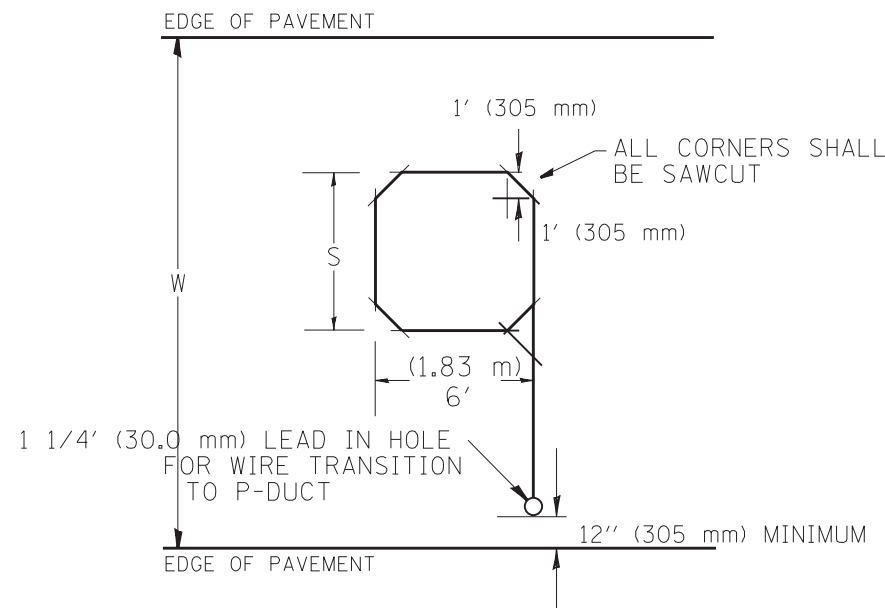

**TYPICAL "S" FT. BY 6' (1.83 m) INDUCTION LOOP SAWCUT LAYOUT FOR RAMPS**

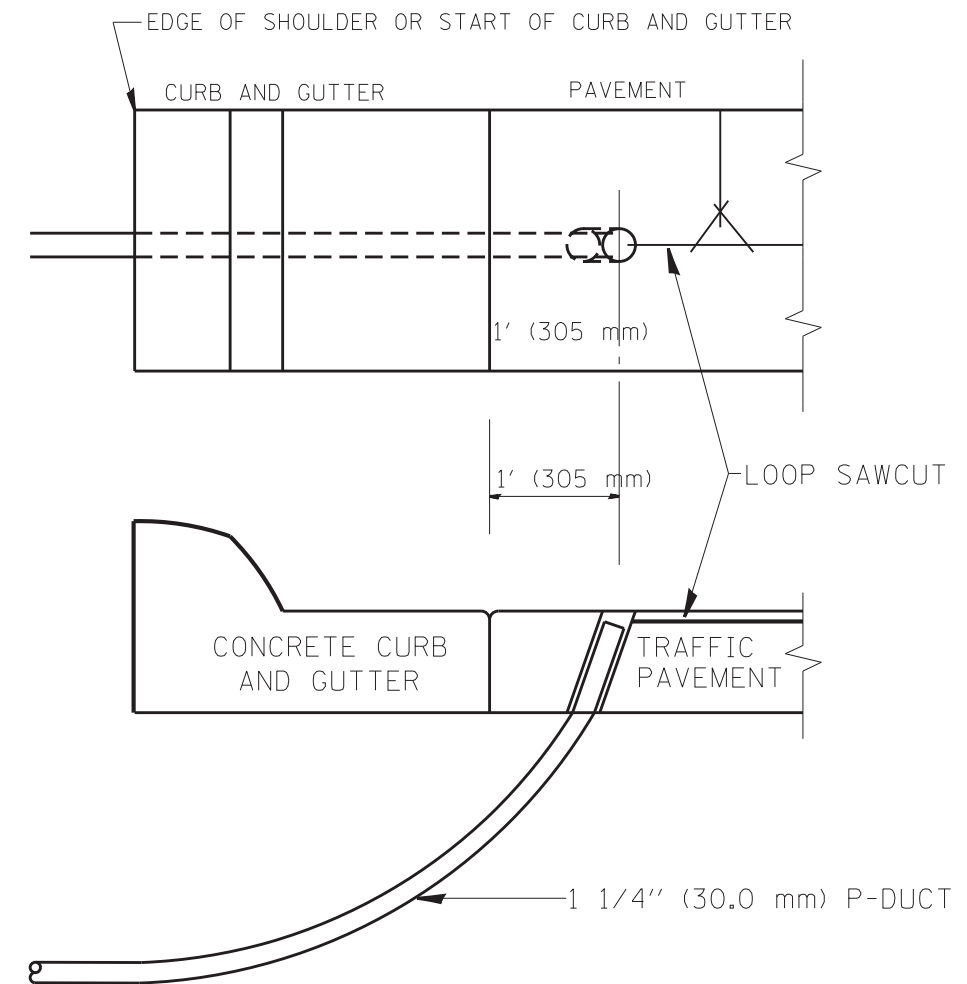

**CURB AND GUTTER LOOP LEAD-IN TRANSITION DETAIL**

**NOTES**

1. EACH LOOP SHALL BE SPLICED TO A 4-C NO.18 TWISTED SHIELDED LEAD IN WHEN 150' (45 m) OR MORE FROM CABINET.
2. LOOPS SHALL BE SPLICED IN HANDHOLES ONLY, OTHERWISE WRITTEN PERMISSION SHALL BE OBTAINED FROM TSC ENGINEER.
3. LOOPS SHALL NOT BE SPLICED IN SERIES.
4. EACH LOOP LEAD IN SHALL BE IDENTIFIED AND PERMANENTLY COLOR CODED IN THE COREHOLE, HANDHOLE & CABINETS THRU WHICH THEY ENTER OR PASS AND TAGGED WITH THE CORRECT NOMENCLATURES.

FILE NAME =	USER NAME = mezag	DESIGNED - R.L.	REVISED - 6/94	<b>STATE OF ILLINOIS DEPARTMENT OF TRANSPORTATION TRAFFIC SYSTEMS CENTER</b>	<b>RECTANGULAR INDUCTION LOOP TYPICAL</b>			F.A. RTE.	SECTION	COUNTY	TOTAL SHEETS	SHEET NO.	
et:\pw\work\p\idot\mezag\d0287541\TSC1P.dgn		DRAWN - G.M.	REVISED - 11/95		SCALE: NONE	SHEET NO.	OF SHEETS	STA.	TO STA.			404	373
		CHECKED - R.L.	REVISED - 05/96		<b>CONTRACT NO.</b>								
		DATE - 6-22-94	REVISED - 10/96		FED. ROAD DIST. NO. ILLINOIS FED. AID PROJECT								