

TYPICAL LOOP SAWCUT LAYOUT

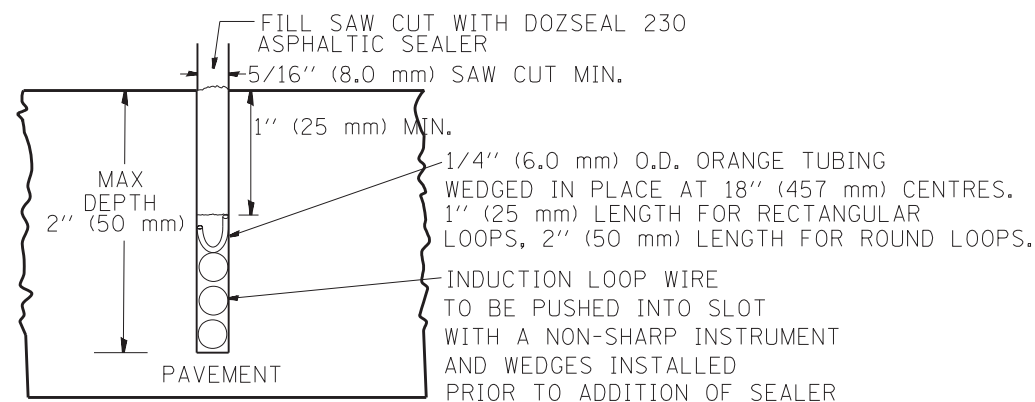

LOOP CROSS SECTION IN PAVEMENT

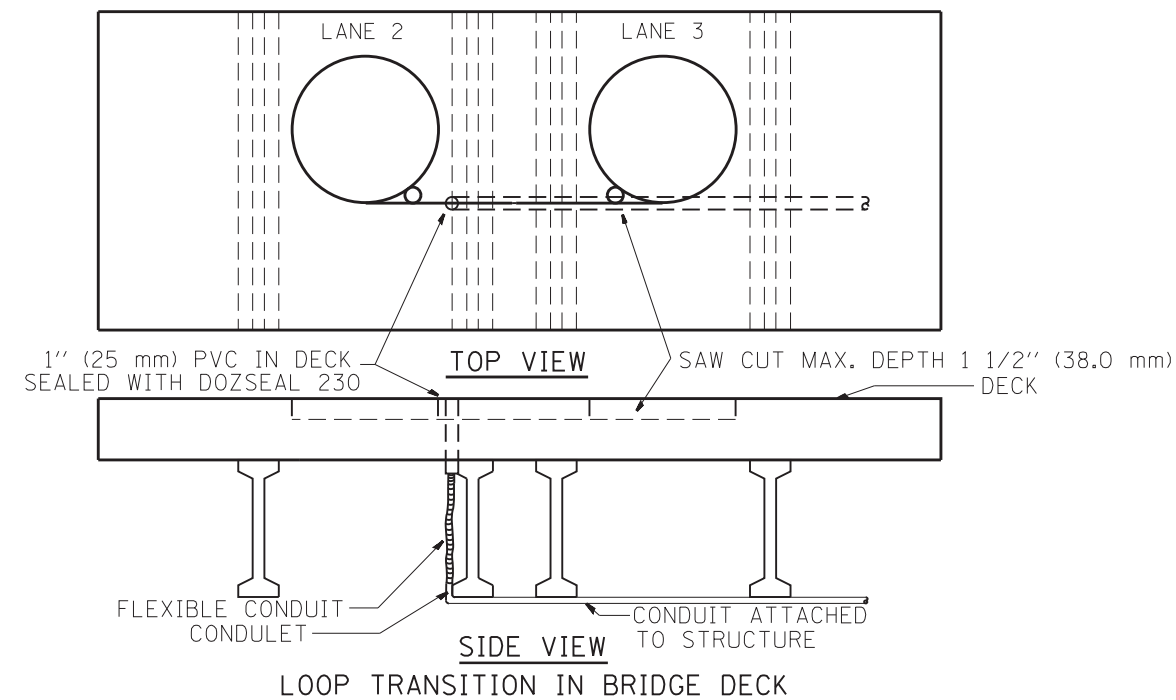
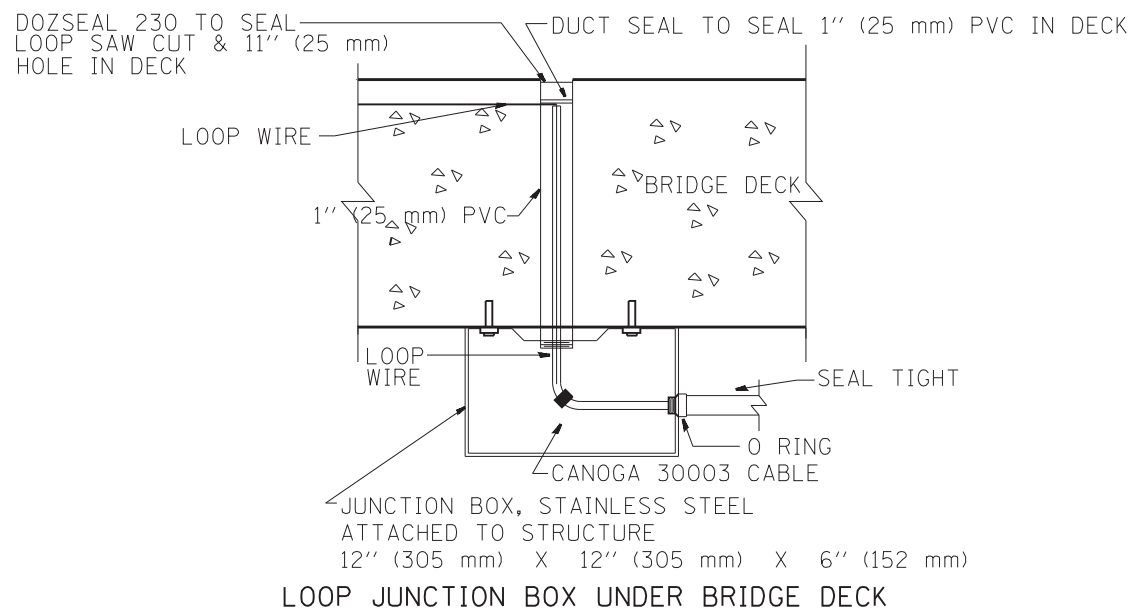
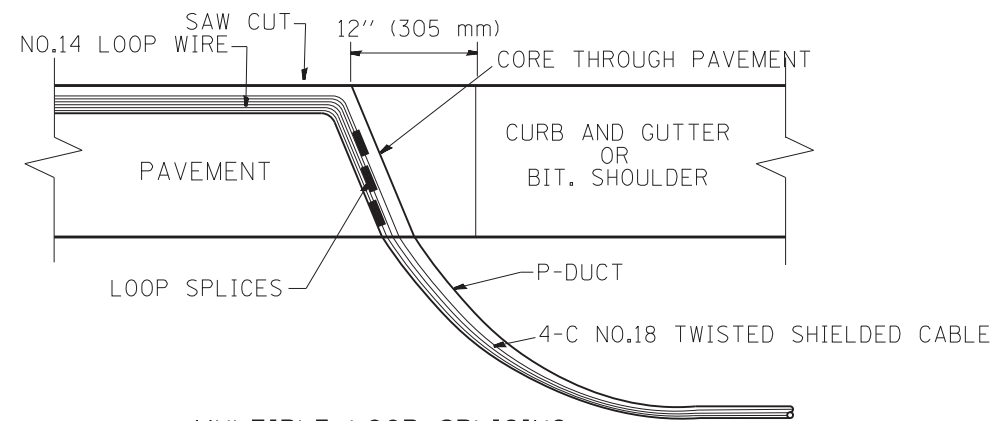

MULTIPLE LOOP SPLICING

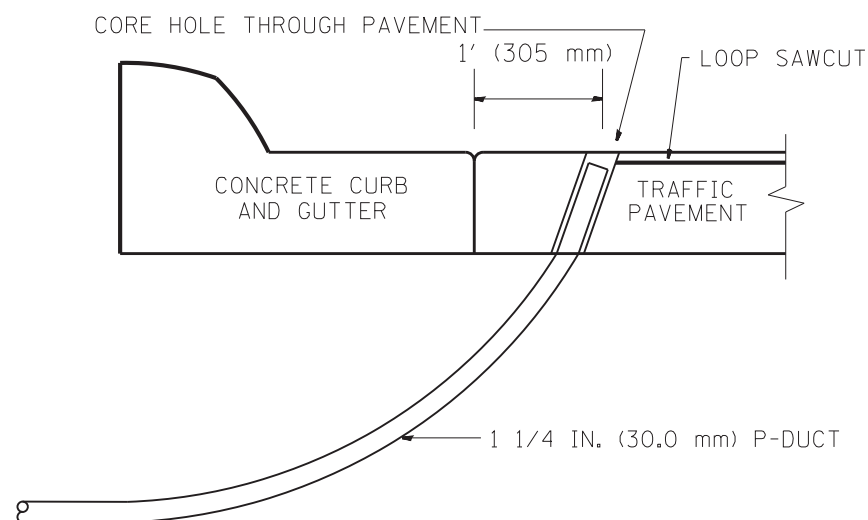

SIDE SECTION LOOP LEAD-IN TRANSITION DETAIL

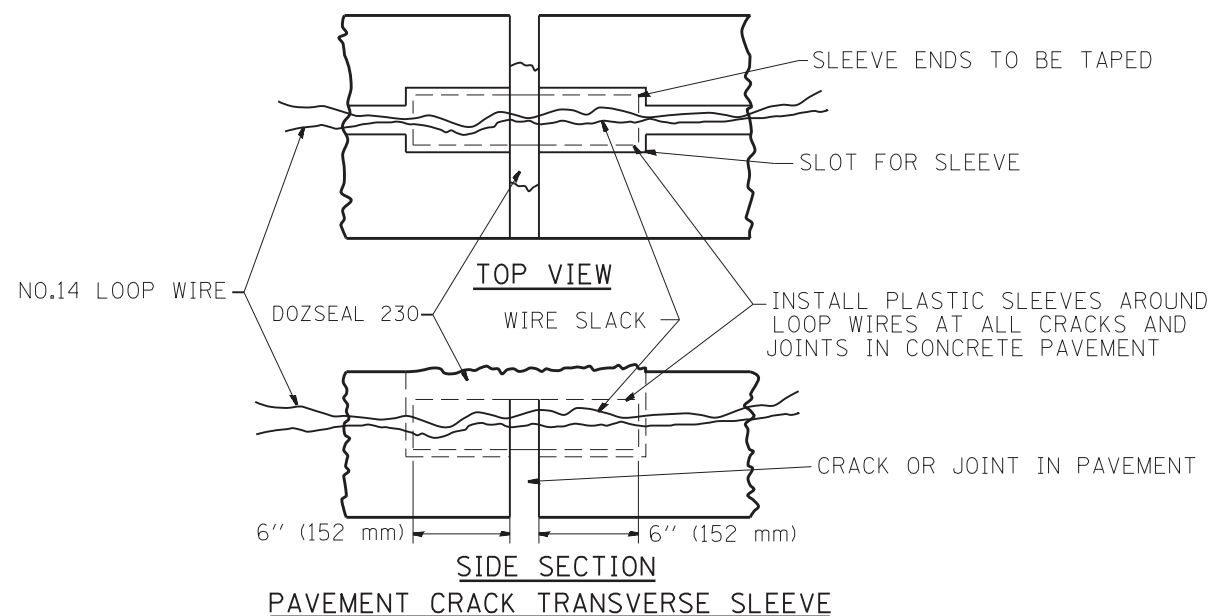

SIDE SECTION PAVEMENT CRACK TRANSVERSE SLEEVE

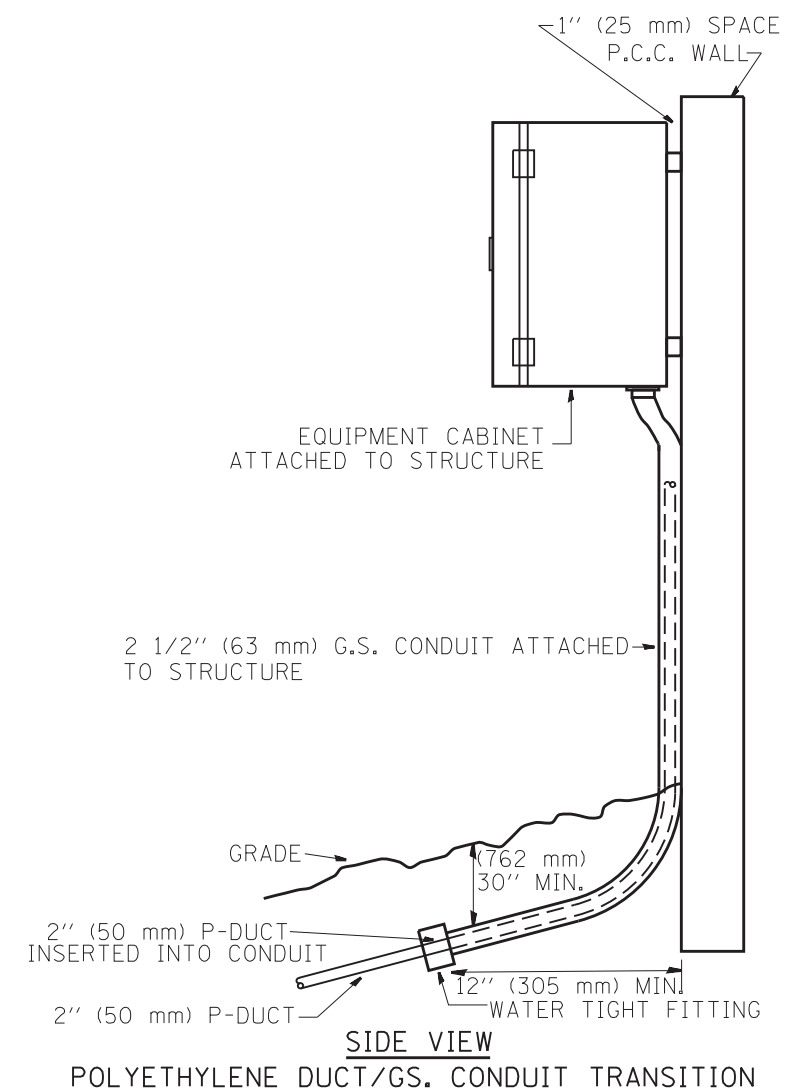

SIDE VIEW POLYETHYLENE DUCT/GS. CONDUIT TRANSITION

FILE NAME =	USER NAME = mezag	DESIGNED - R.L.	REVISED - 06/94	STATE OF ILLINOIS DEPARTMENT OF TRANSPORTATION TRAFFIC SYSTEMS CENTER	LOOP, CONDUIT & DUCT INSTALLATION DETAILS			F.A. RTE.	SECTION	COUNTY	TOTAL SHEETS	SHEET NO.	
es:\pw\work\p\idot\mezag\d0287541\TSCTYP.dgn		DRAWN - G.M.	REVISED - 03/95		SCALE: NONE	SHEET NO.	OF SHEETS	STA.	TO STA.			404	374
	PLOT SCALE = 100.0000' / 1"	CHECKED - R.L.	REVISED - 11/95		CONTRACT NO.								
	PLOT DATE = 7/26/2012	DATE - 06/22/94	REVISED - 10/96		FED. ROAD DIST. NO. ILLINOIS FED. AID PROJECT								