

ILL. 72 / ILL. 83

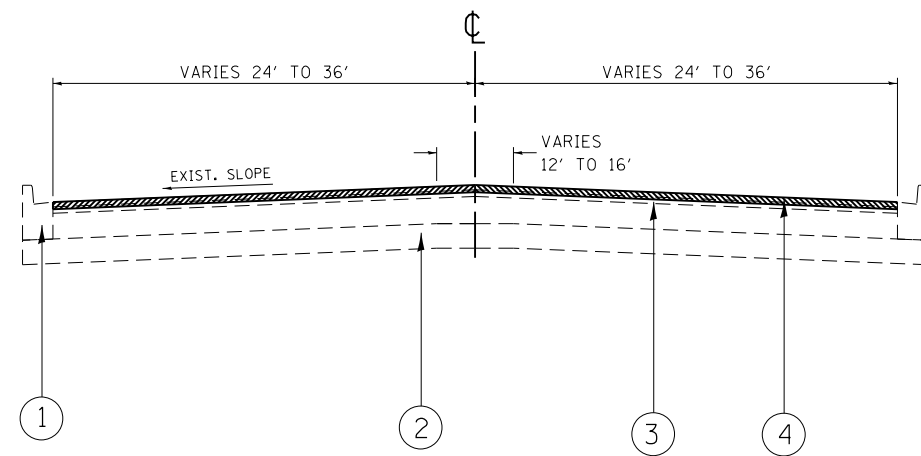

EXISTING TYPICAL SECTION
 ILL. 72 / ILL. 83
 STA. 221+02 TO STA. 267+47
 STA. 299+54 TO STA. 322+09
 STA. 323+78 TO STA. 349+40

LEGEND:

- ① EXISTING B-6.24 CURB & GUTTER
- ② EXISTING PCC BASE COURSE, 10" (±)
- ③ EXISTING HOT-MIX ASPHALT SURFACE, 3" (±)
- ④ PROPOSED HOT-MIX ASPHALT SURFACE REMOVAL, 3"
- ⑤ PROPOSED POLYMERIZED LEVELING BINDER (MACHINE METHOD), IL-4.75, N50, 1"
- ⑥ PROPOSED POLYMERIZED HOT-MIX ASPHALT SURFACE COURSE, MIX "F", N90, 2"

ILL. 72 / ILL. 83

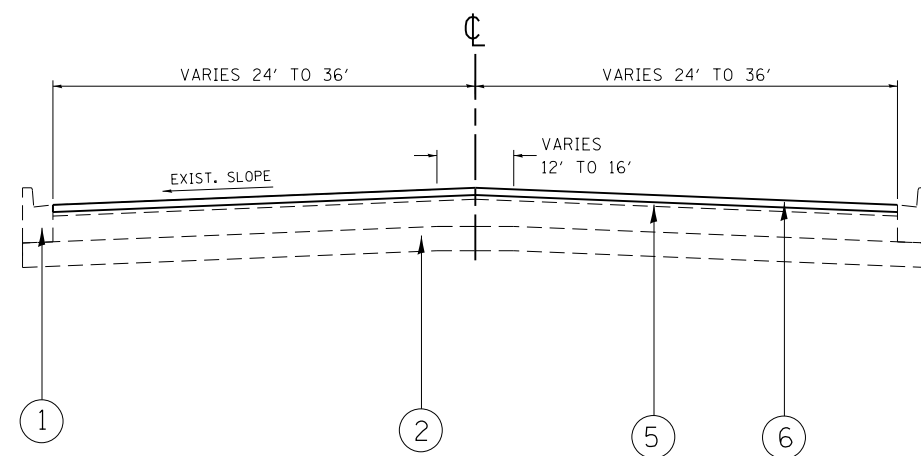

EXISTING TYPICAL SECTION
 ILL. 72 / ILL. 83
 STA. 221+02 TO STA. 267+47
 STA. 299+54 TO STA. 322+09
 STA. 323+78 TO STA. 349+40

NOTES

- 1. THE CONTRACTOR SHALL PATCH THE ROADWAY BEFORE MILLING

FILE NAME =	USER NAME = chrzesclr	DESIGNED -	REVISED -	STATE OF ILLINOIS DEPARTMENT OF TRANSPORTATION	ILL. 72 / ILL. 83 EXISTING AND PROPOSED TYPICAL SECTIONS			F.A.P. RTE.	SECTION	COUNTY	TOTAL SHEETS	SHEET NO.
et:\pw\work\pwidot\chrzesclr\d0245762\0107711-sht-plan.dgn		DRAWN -	REVISED -		341	31R-RS-1	COOK	36	7			
PLOT SCALE = 100.0000' / in.		CHECKED -	REVISED -		CONTRACT NO. 60M10							
PLOT DATE = 12/20/2012		DATE -	REVISED -		ILLINOIS FED. AID PROJECT							