

**PAVEMENT MIX LEGEND**

- (A) PROPOSED HMA SURFACE REMOVAL 2 1/2\"/>
  - POLYMERIZED LEVELING BINDER (MACHINE METHOD), IL-4.75, N50 -1\"/>
  - POLYMERIZED HMA SURFACE COURSE, STONE MATRIX ASPHALT, N80 -2\"/>
- (B) PROPOSED HMA SURFACE REMOVAL 2 1/2\"/>
  - POLYMERIZED LEVELING BINDER (MACHINE METHOD), IL-4.75, N50 -1\"/>
  - HMA SURFACE COURSE, MIX "D", N70 -2\"/>

**PAVEMENT MARKING LEGEND (SEE NOTE 1)**

- (1) THERMOPLASTIC PAVEMENT MARKING 4\"/>
- (2) THERMOPLASTIC PAVEMENT MARKING 8\"/>
- (3) THERMOPLASTIC PAVEMENT MARKING 4\"/>
- (4) THERMOPLASTIC PAVEMENT MARKING 4\"/>
- (5) THERMOPLASTIC PAVEMENT MARKING 4\"/>
- (6) THERMOPLASTIC PAVEMENT MARKING 6\"/>
- (7) THERMOPLASTIC PAVEMENT MARKING 8\"/>
- (8) THERMOPLASTIC PAVEMENT MARKING 12\"/>
- (9) THERMOPLASTIC PAVEMENT MARKING 12\"/>
- (10) THERMOPLASTIC PAVEMENT MARKING 24\"/>
- (11) THERMOPLASTIC PAVEMENT MARKING LETTERS AND SYMBOLS (TYP)

**NOTES:**

1. REFER TO DISTRICT 1 TYPICAL PAVEMENT MARKINGS (TC-13) FOR ADDITIONAL INFORMATION.
2. REFER TO DISTRICT 1 RAISED REFLECTIVE PAVEMENT MARKERS (TC-11) FOR LOCATION AND SPACING OF RAISED REFLECTIVE PAVEMENT MARKINGS

- SURFACE REMOVAL BUTT JOINT  
SEE BUTT JOINTS AND HMA TAPER DETAILS (BD32)
- CONCRETE MEDIAN SURFACE REMOVAL AND REPLACEMENT WITH TOPSOIL AND SEED. SEE TYPICAL SECTIONS AND LANDSCAPING PLANS FOR DETAILS
- CONCRETE MEDIAN SURFACE REMOVAL AND REPLACEMENT WITH STAMPED COLORED PCC MEDIAN SURFACE.

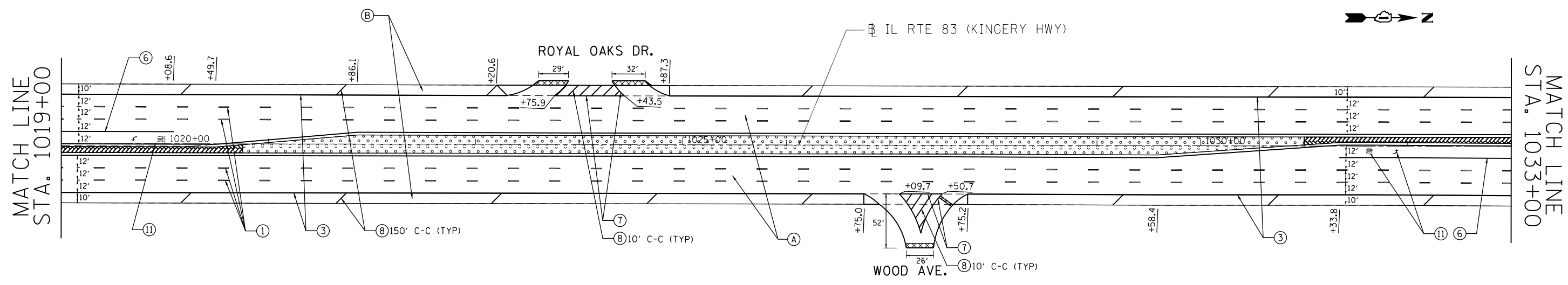

FILE NAME =	USER NAME = Bilgramise	DESIGNED -	REVISED - SB 3/14/13
et:\pw_work\pwidot\bilgramise\d0315608\100313-shr-plan.dgn		DRAWN -	REVISED -
	PLOT SCALE = 100.0000' / in.	CHECKED -	REVISED -
#MODELNAME#	PLOT DATE = 3/15/2013	DATE -	REVISED -

**STATE OF ILLINOIS  
DEPARTMENT OF TRANSPORTATION**

**IL 83 (IL 19 TO IL 64)  
ROADWAY AND PAVEMENT MARKING PLAN**

SCALE:	SHEET	OF	SHEETS	STA.	TO	STA.
--------	-------	----	--------	------	----	------

F.A.P. RTE.	SECTION	COUNTY	TOTAL SHEETS	SHEET NO.
344	540R-RS-3	DUPAGE	38	15
CONTRACT NO. 60V54				
ILLINOIS FED. AID PROJECT				