

EXISTING:

- (A) EXISTING 10" PCC PAVEMENT
- (B) EXISTING HMA OVERLAY
- (Bb) EXISTING HMA OVERLAY, VARIES 2 1/2"
- (Bb) EXISTING HMA OVERLAY, VARIES 4"
- (C) EXISTING 4" STABILIZED SUBBASE
- (D) EXISTING SUB-BASE GRANULAR MATERIAL TYPE A 6"
- (E) EXISTING COMBINATION CONCRETE CURB AND GUTTER TYPE B-6.18
- (F) EXISTING CONCRETE CURB TYPE B
- (G) EXISTING CONCRETE MEDIAN SURFACE 4"
- (H) EXISTING CONCRETE MEDIAN TYPE 6
- (I) EXISTING #5 TIE BAR
- (J) EXISTING #4 TIE BAR
- (K) EXISTING STABILIZED SHOULDERS, VARIES 12"-14"
- (L) EXISTING AGGREGATE SHOULDERS
- (M) EXISTING FENCE
- (N) EXISTING STEEL GUARDRAIL

PROPOSED:

- (1) POLYMERIZED HMA SURFACE COURSE, MIX "F", N90, 1 3/4"
- (2) POLYMERIZED LEVELING BINDER (MACHINE METHOD), IL-4.75, N50, 3/4" & VARIES
- (3) PORTLAND CEMENT CONCRETE SHOULDERS 10 1/4"
- (4) TEMPORARY PAVEMENT, (10")
- (4A) HOT-MIX ASPHALT SURFACE COURSE, MIX "D", N70, 2"
- (4B) HOT-MIX ASPHALT BINDER COURSE, IL 19.0, N70, 8"
- (5) AGGREGATE BASE COURSE, TYPE B (6")
- (6) HOT-MIX ASPHALT BASE COURSE, 10 1/4"
- (7) AGGREGATE SHOULDERS, TYPE B 6"
- (8) COMBINATION CONCRETE CURB AND GUTTER, TYPE B-6.18
- (9) PCC PAVEMENT, 10 1/4" (JOINTED)
- (10) STABILIZED SUBBASE - HOT-MIX ASPHALT, 4 1/2"
- (11) STEEL PLATE BEAM GUARDRAIL, TY. A 6FT POSTS
- (12) CONCRETE CURB, TYPE B
- (13) CONCRETE MEDIAN SURFACE, 4"
- (14) CONCRETE MEDIAN, TY. SB
- (15) BITUMINOUS MATERIALS (PRIME COAT)
- (16) REGRADING AND LANDSCAPING TOPSOIL FURNISH AND PLACE, 4" SEEDING, CLASS A2
- (17) HMA SURFACE REMOVAL, 2 1/2"
- (18) TIE BARS (INCLUDED IN THE COST OF THE PCC ITEM INVOLVED)
- (19) CHAIN LINK FENCE, 4'
- (20) AGGREGATE SUBGRADE IMPROVEMENT
- (21) REMOVAL AND DISPOSAL OF UNSUITABLE MATERIAL
- (22) HMA SURFACE REMOVAL, VARIABLE DEPTH
- (23) TEMPORARY PAVEMENT, (11 1/2")
- (23A) HOT-MIX ASPHALT SURFACE COURSE, MIX "F", N90, 2"
- (23B) HOT-MIX ASPHALT BINDER COURSE, IL 19.0, N90, 9 1/2"

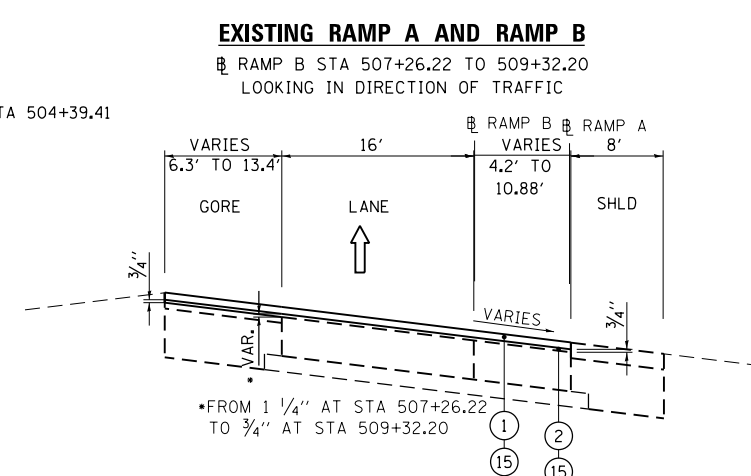
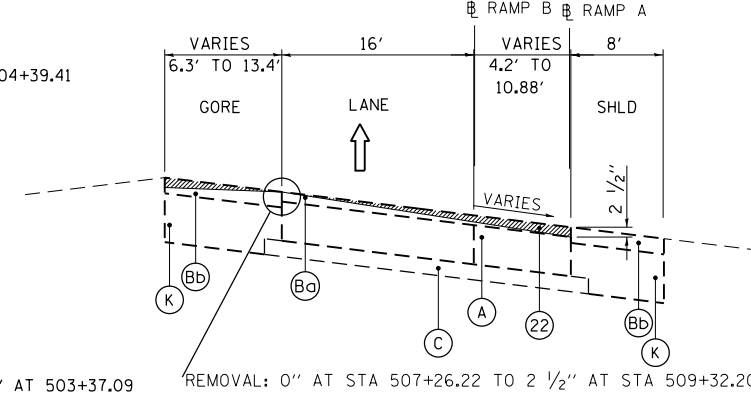
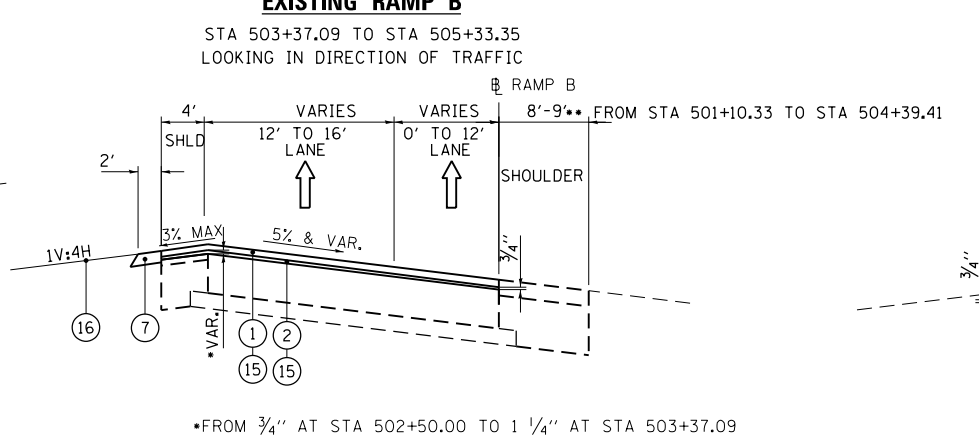
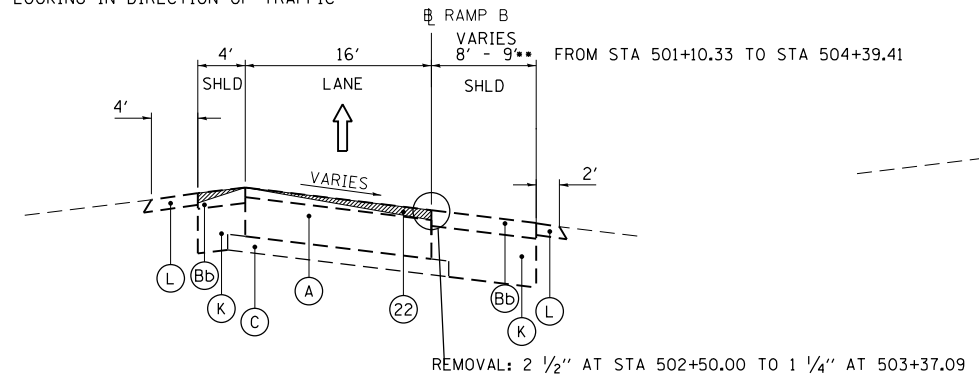
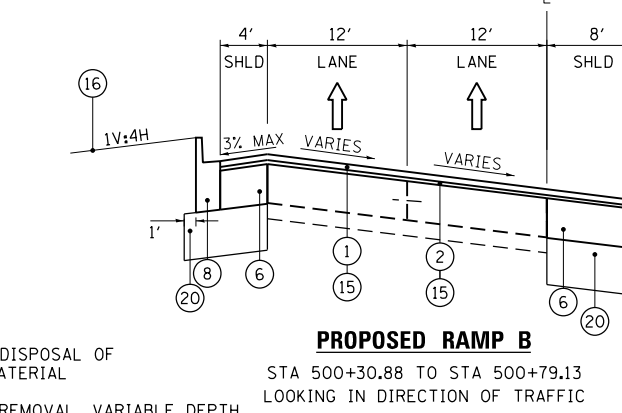
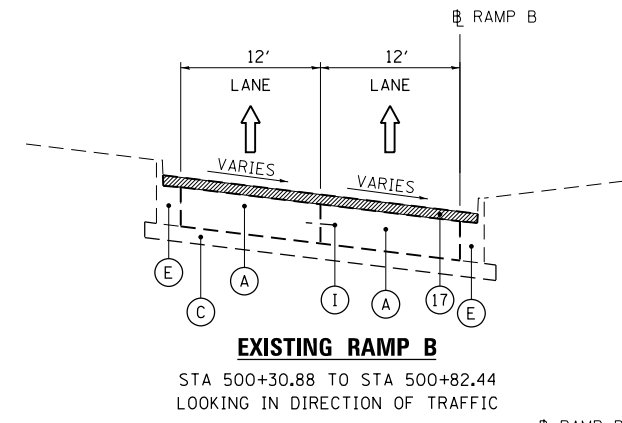
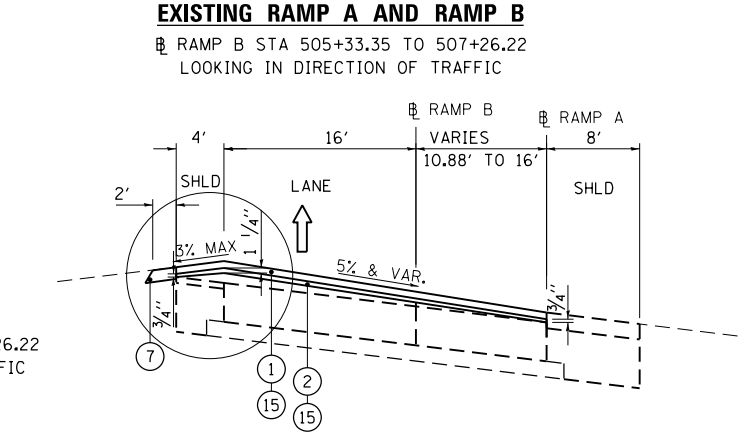
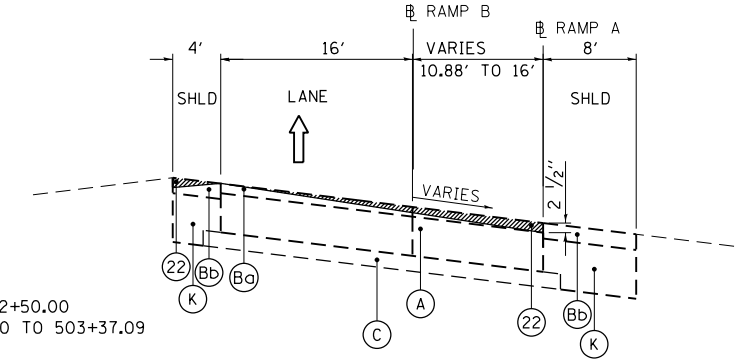
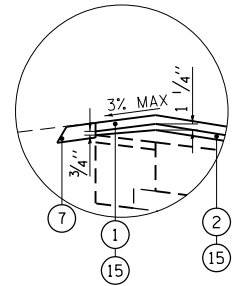
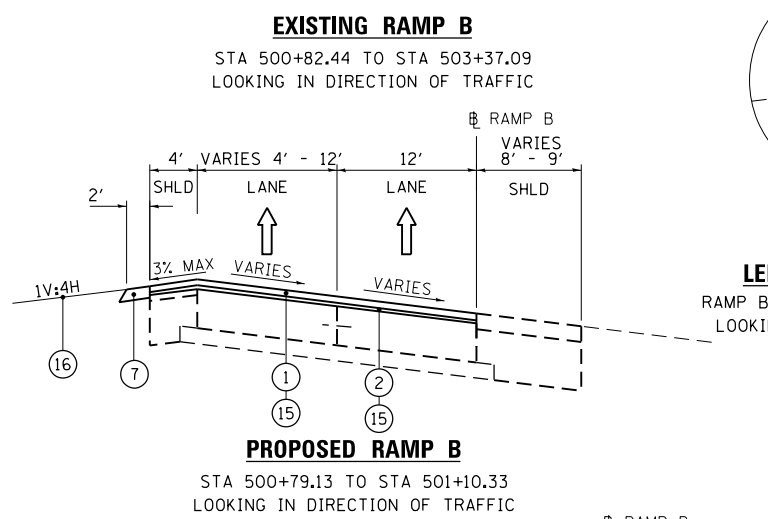
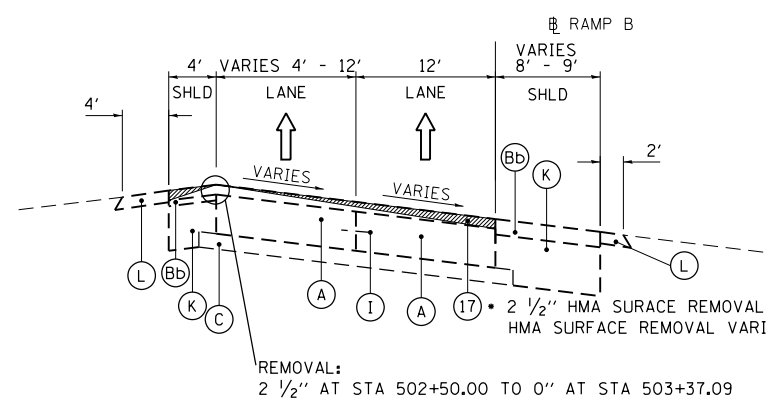
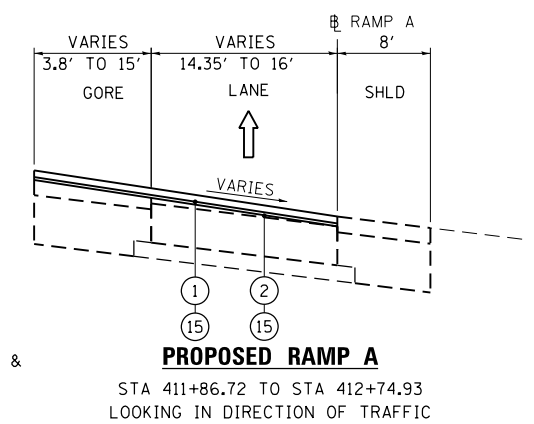
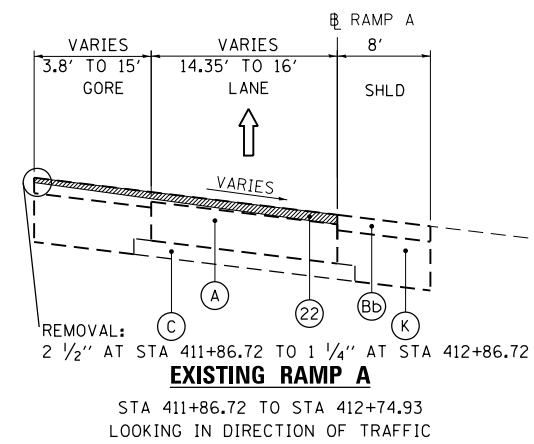

BOWMAN, BARRETT & ASSOCIATES INC.
CONSULTING ENGINEERS
Chicago, Illinois
312.228.0100
www.bbandainc.com

USER NAME = default	DESIGNED - JG	REVISED -
PLOT SCALE = *SCALE*	CHECKED - OC	REVISED -
PLOT DATE = 12/7/2012	DATE - 11/08/2012	REVISED -

STATE OF ILLINOIS
DEPARTMENT OF TRANSPORTATION

RAMP A AND B TYPICAL SECTIONS

FILE NAME =	USER NAME = default	DESIGNED - JG	REVISED -	F.A.I. RTE. =	SECTION =	COUNTY =	TOTAL SHEETS =	SHEET NO. =
*FILE#		DRAWN - JG	REVISED -	94	2012-060-BR	COOK	285	23
		CHECKED - OC	REVISED -	CONTRACT NO. 60V61			ILLINOIS FED. AID PROJECT	
		DATE - 11/08/2012	REVISED -	SCALE: N/A	SHEET NO. 2 OF 5 SHEETS	STA. N/A TO STA. N/A		

S:\1072-06-CADD\0160V61_Sheets\0160V61-ark-typical.dgn