

12/6/2012 9:31:54 AM p:\projects\3010\_stony\_island\_feeder - bbe\project\_work\disciplines\traffic\_signals\sheet\0160J12-sht-TSD-05.dgn

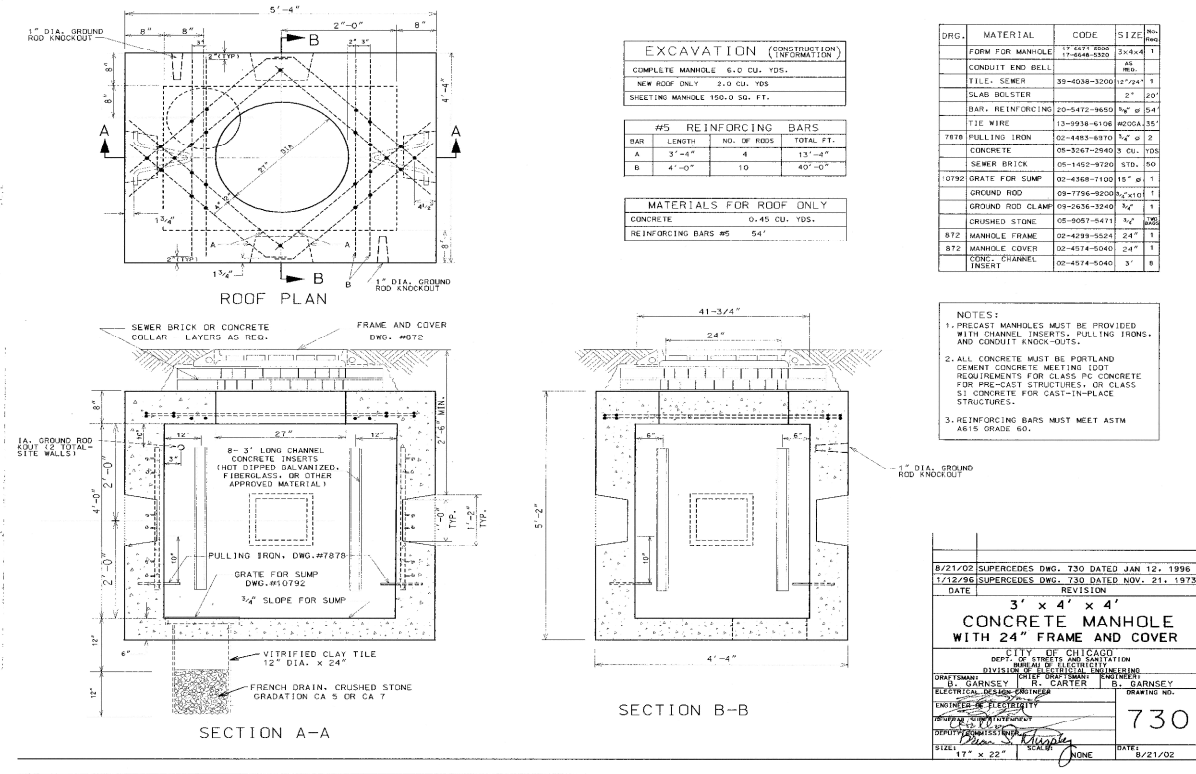

USER NAME = sadhikari	DESIGNED - SA	REVISED -
PLOT SCALE = 50.000' / IN.	DRAWN - SA	REVISED -
PLOT DATE = 12/6/2012	CHECKED - BKS	REVISED -
	DATE - 12/07/2012	REVISED -

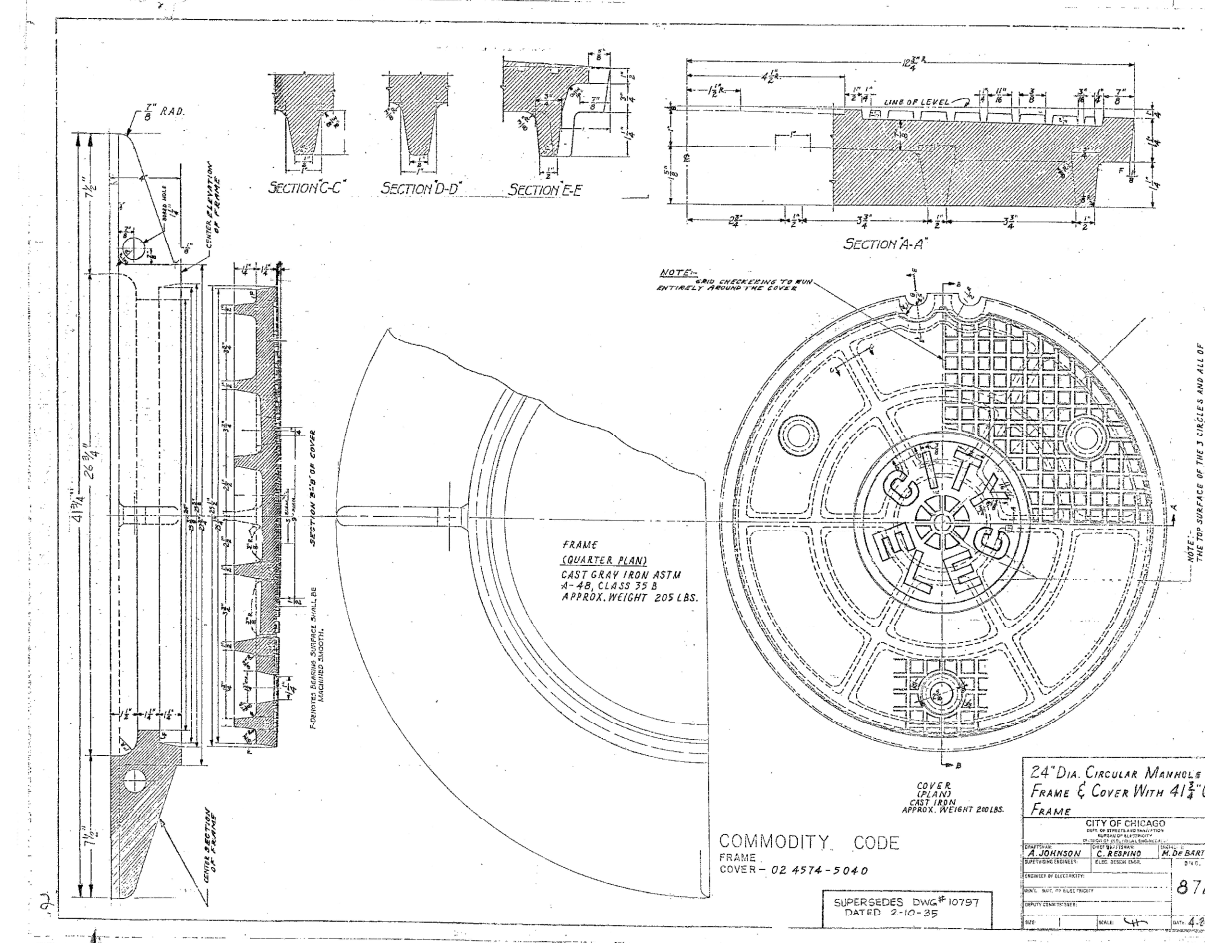
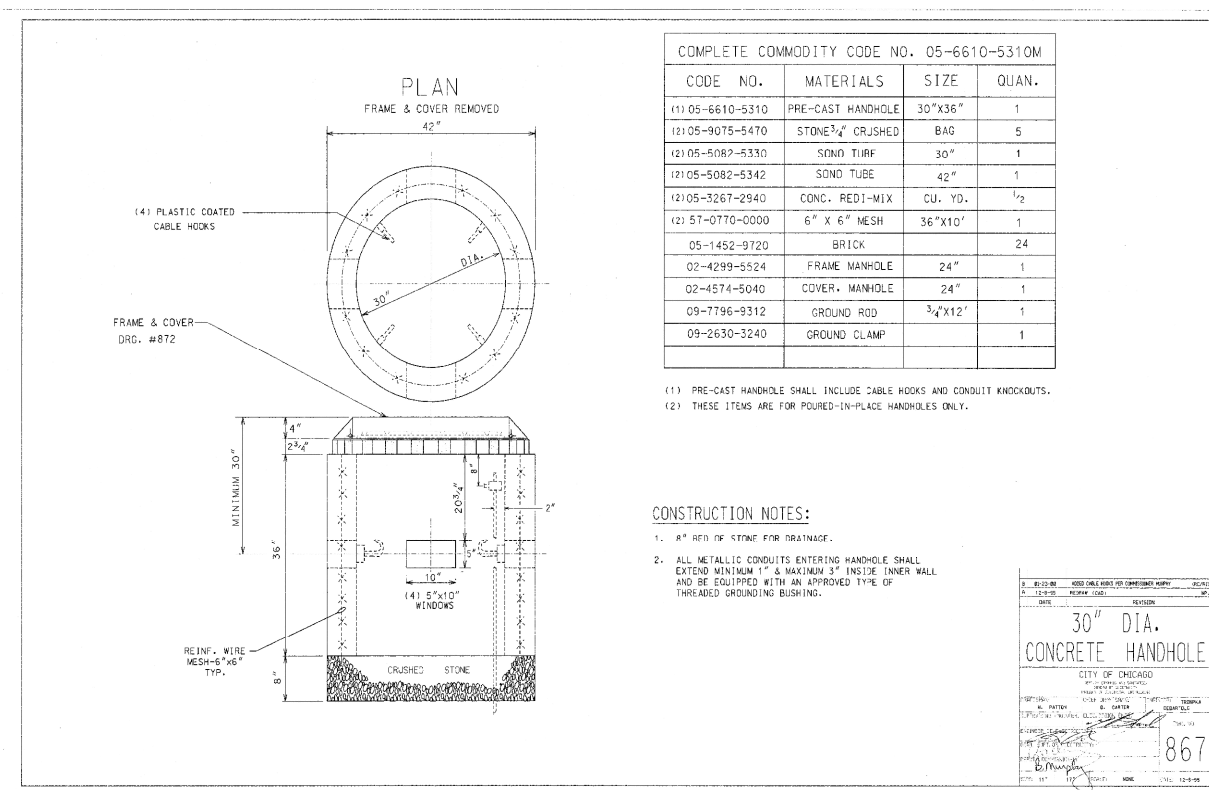
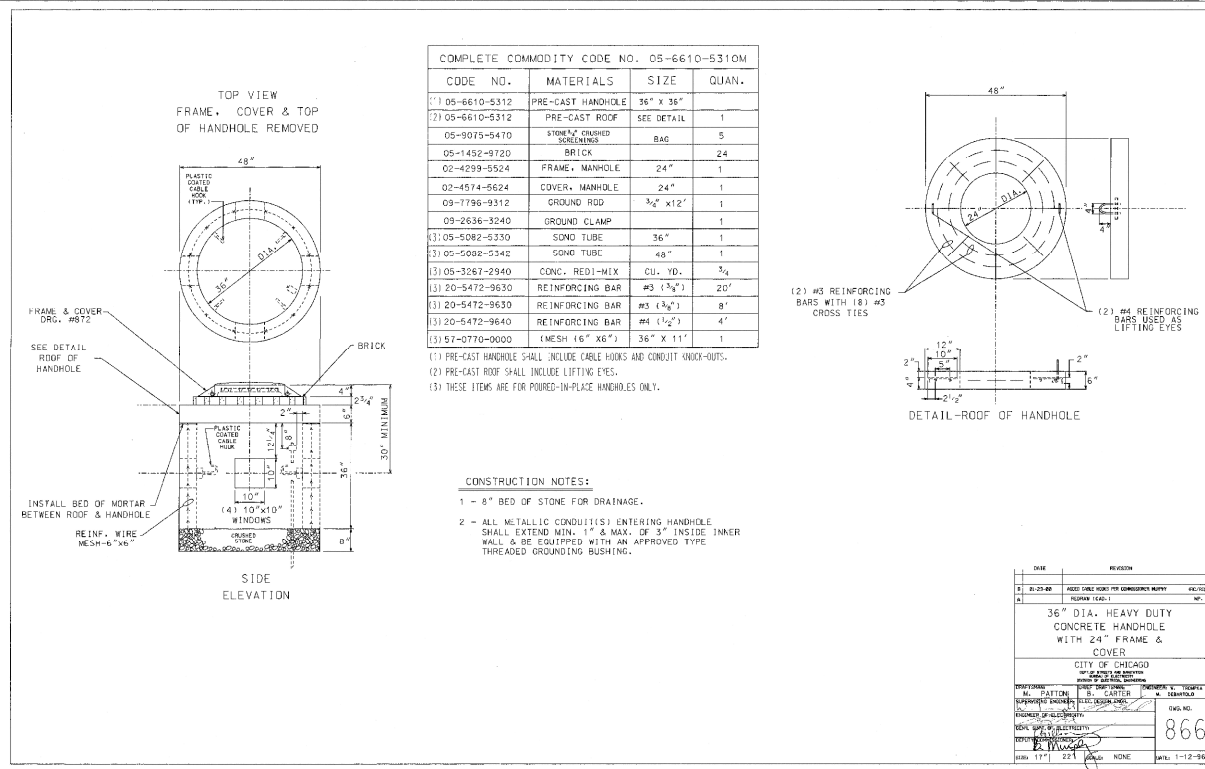

STATE OF ILLINOIS  
 DEPARTMENT OF TRANSPORTATION

SCALE:	SHEET NO.	OF SHEETS	STA.	TO STA.

F.A.I. RTE.	SECTION	COUNTY	TOTAL SHEETS	SHEET NO.
94	2012-060-BR	COOK	285	134
CONTRACT NO. 60W61			ILLINOIS FED. AID PROJECT	