

**PARTIAL PLAN**  
(Unit 2)

**MIN. BAR LAP**  
#5 = 3'-3"  
#6 = 3'-10"

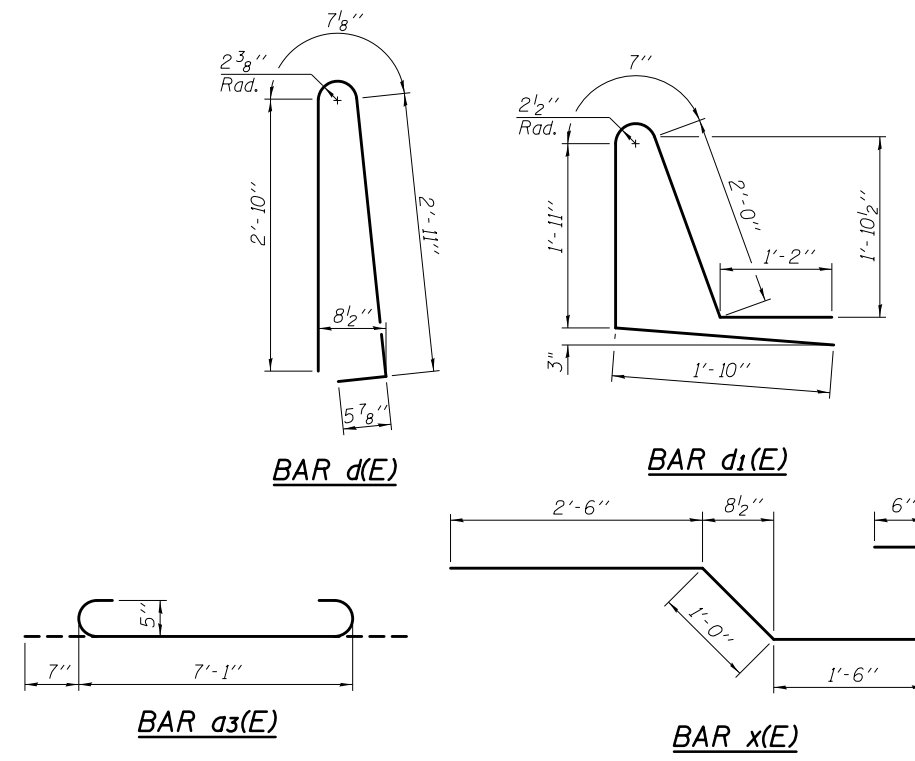

**UNIT 2**  
**BILL OF MATERIAL**

Bar	No.	Size	Length	Shape	
a(E)	445	#5	27'-4"	—	
a1(E)	352	#5	27'-0"	—	
a2(E)	452	#6	6'-6"	—	
a3(E)	18	#5	8'-3"	U	
a4(E)	2	#5	21'-6"	—	
a5(E)	8	#5	27'-4"	—	
a6(E)	8	#5	1'-6"	—	
b3(E)	270	#5	32'-2"	—	
b4(E)	162	#6	21'-5"	—	
b5(E)	240	#5	29'-3"	—	
d(E)	564	#5	6'-10"	L	
d1(E)	564	#5	7'-6"	L	
d2(E)	3	#6	5'-1"	L	
d3(E)	6	#6	8'-11"	L	
e(E)	56	#4	16'-8"	—	
e1(E)	64	#4	12'-7"	—	
e4(E)	28	#4	18'-6"	—	
e5(E)	28	#4	16'-0"	—	
e7(E)	28	#4	15'-7"	—	
e9(E)	28	#4	17'-4"	—	
e12(E)	12	#4	24'-0"	—	
e15(E)	6	#4	26'-6"	—	
e21(E)	12	#8	26'-1"	—	
e22(E)	8	#8	12'-7"	—	
e25(E)	6	#8	28'-9"	—	
x(E)	42	#5	6'-4"	U	
Reinforcement Bars, Epoxy Coated				Pound	62,340
Concrete Superstructure				Cu. Yd.	278.0
Bridge Deck Grooving				Sq. Yd.	654
Protective Coat				Sq. Yd.	970

2/26/09 PM

12/7/2012

S:\1072\_05\_CADD\Structure\1\SN\_0162437\CADD Sheets\0162437-60J12-018-SP02.dgn

BOWMAN, BARRETT & ASSOCIATES INC.  
CONSULTING ENGINEERS  
Chicago, Illinois  
312.228.0100  
www.bbainc.com

USER NAME =	DESIGNED - IYL	REVISIONS
PLOT SCALE =	CHECKED - BAK	REVISIONS
PLOT DATE = 11/08/2012	DRAWN - MTR	REVISIONS
	CHECKED - IYL	REVISIONS

STATE OF ILLINOIS  
DEPARTMENT OF TRANSPORTATION

**SUPERSTRUCTURE PLAN II**  
**STRUCTURE NO. 016-2437**  
SHEET NO. S-18 OF S-83 SHEETS

F.A.I. RTE.	SECTION	COUNTY	TOTAL SHEETS	SHEET NO.
94	2012-060-BR	COOK	285	181
CONTRACT NO. 60V61				
ILLINOIS FED. AID PROJECT				