

2/26/19 PM

SA:\1072\_05\_CADD\Structure\1\SN\_0162437\CADD Sheet\0162437-60J12-942-AB01Rem.dgn 12/7/2012

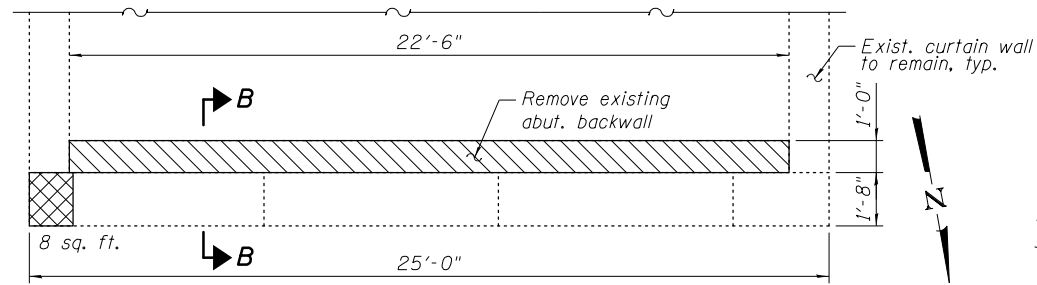

**SECTION A-A**

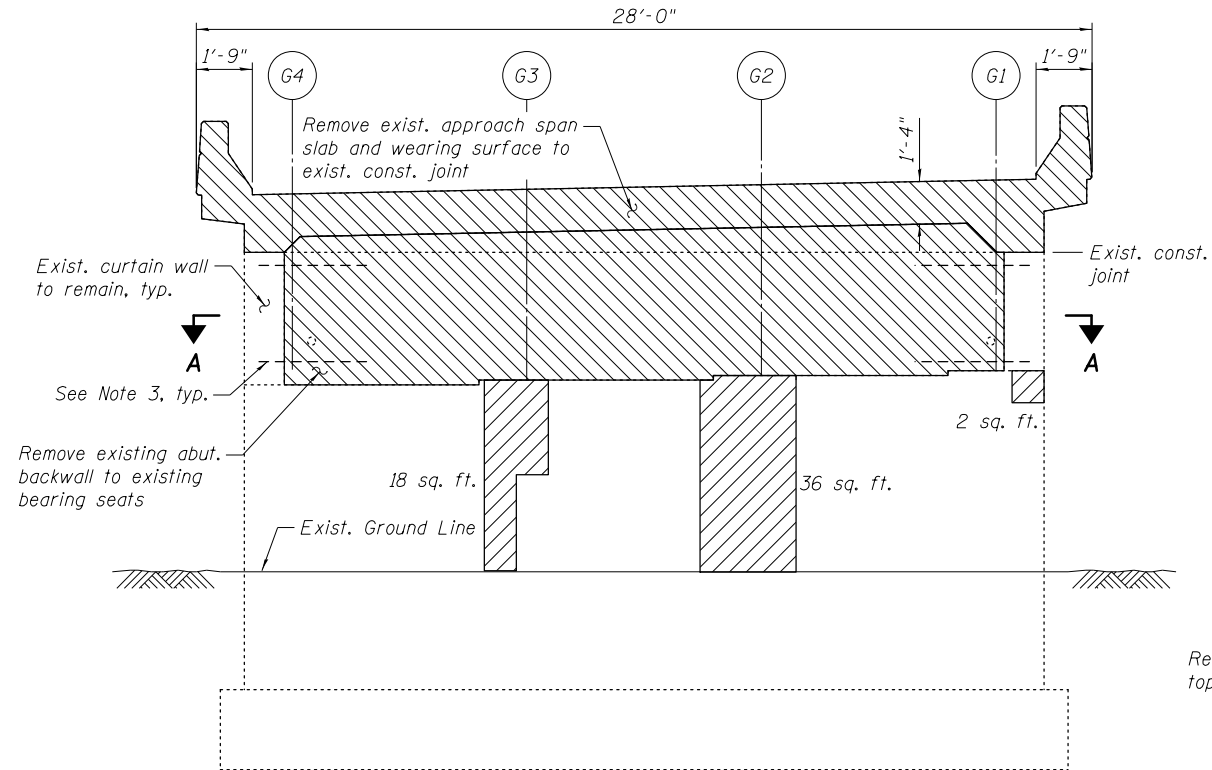

**ELEVATION**  
(Looking South)

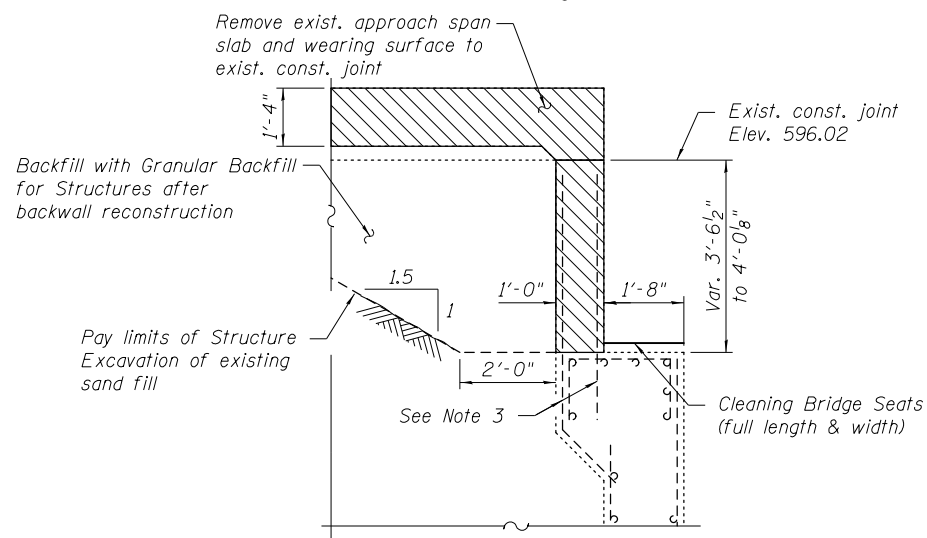

**SECTION B-B**

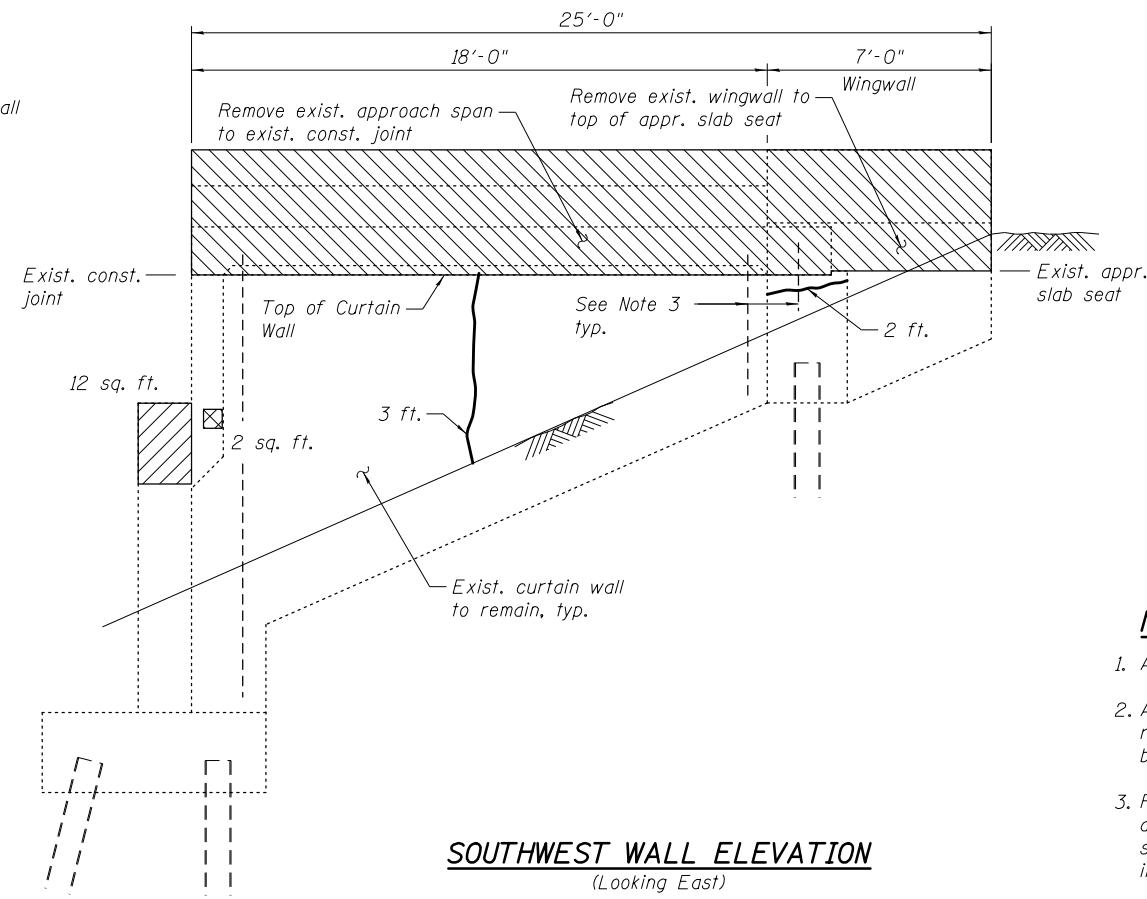

**SOUTHWEST WALL ELEVATION**  
(Looking East)  
(Backwall removal not shown for clarity)

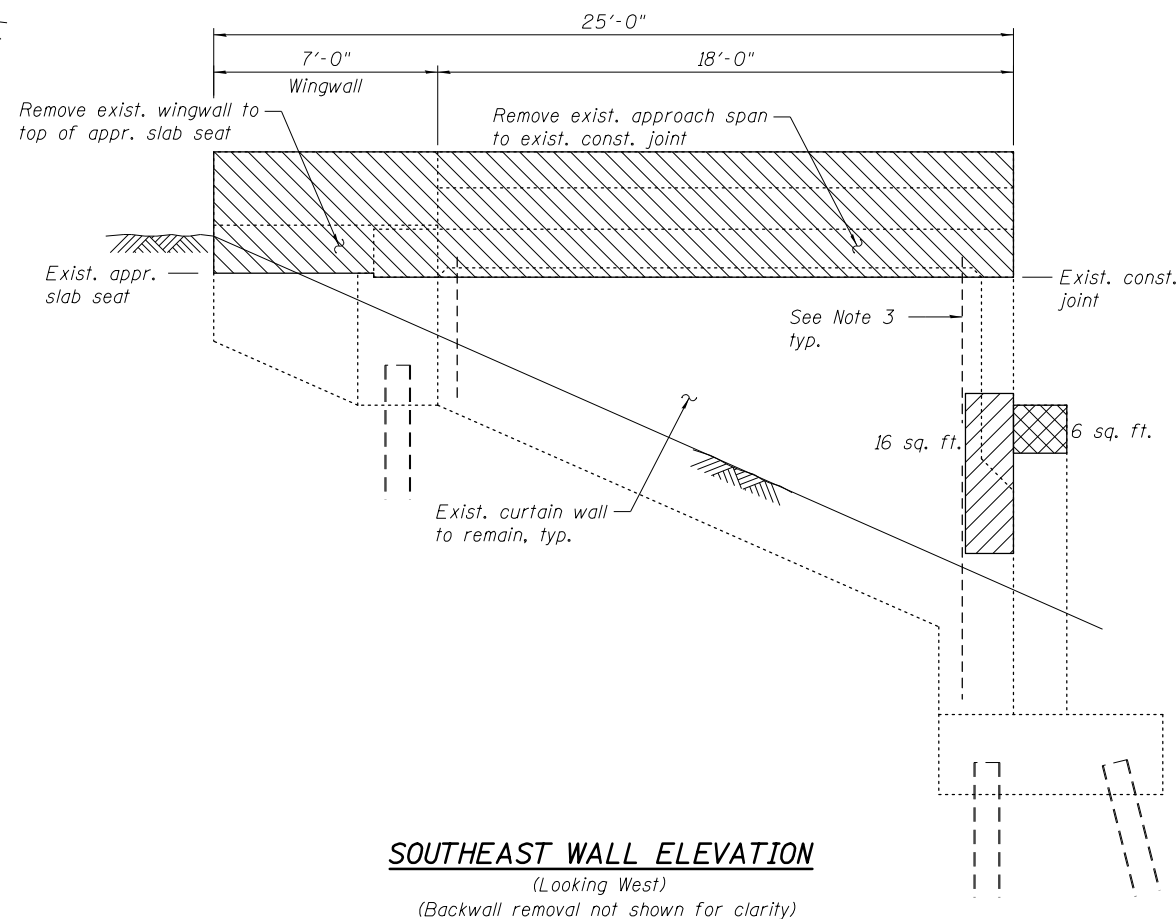

**SOUTHEAST WALL ELEVATION**  
(Looking West)  
(Backwall removal not shown for clarity)

**NOTES:**

1. Actual quantities of repairs shall be approved by the Engineer.
2. Any existing reinforcement to remain that is damaged during removal operations shall be repaired or replaced with an approved bar splicer or anchorage system at no additional cost.
3. Reinforcement in existing abutment backwall, curtain walls, and approach bent extending into removal area shall be cleaned, straightened, and incorporated into the new construction. Cost included with Concrete Removal.

**LEGEND**

- Concrete Removal
- Structural Repair of Concrete (Depth equal to or less than 5 inches)
- Structural Repair of Concrete (Depth greater than 5 inches)
- Epoxy Crack Injection

**BILL OF MATERIAL**

ITEM	UNIT	QUANTITY
Structure Excavation	Cu. Yd.	17
Granular Backfill for Structures	Cu. Yd.	17
Concrete Removal	Cu. Yd.	38.0
Structural Repair of Concrete (Depth equal to or less than 5 inches)	Sq. Ft.	84
Structural Repair of Concrete (Depth greater than 5 inches)	Sq. Ft.	16
Epoxy Crack Injection	Foot	5
Cleaning Bridge Seats	Sq. Ft.	42
Jack and Remove Existing Bearings	Each	4

BOWMAN, BARRETT & ASSOCIATES INC.  
CONSULTING ENGINEERS  
Chicago, Illinois  
312.228.0100  
www.bbainc.com



USER NAME =  
PLOT SCALE =  
PLOT DATE = 11/08/2012

DESIGNED - TL  
CHECKED - BAK  
DRAWN - TL  
CHECKED - BAK

REVISED -  
REVISED -  
REVISED -  
REVISED -

STATE OF ILLINOIS  
DEPARTMENT OF TRANSPORTATION

ABUTMENT 1 REMOVAL AND REPAIR DETAILS I  
STRUCTURE NO. 016-2437

SHEET NO. S-42 OF S-83 SHEETS

F.A.I. RTE.	SECTION	COUNTY	TOTAL SHEETS	SHEET NO.
94	2012-060-BR	COOK	285	205
CONTRACT NO. 60V61				
ILLINOIS FED. AID PROJECT				