

ELEVATION AT ABUTMENTS

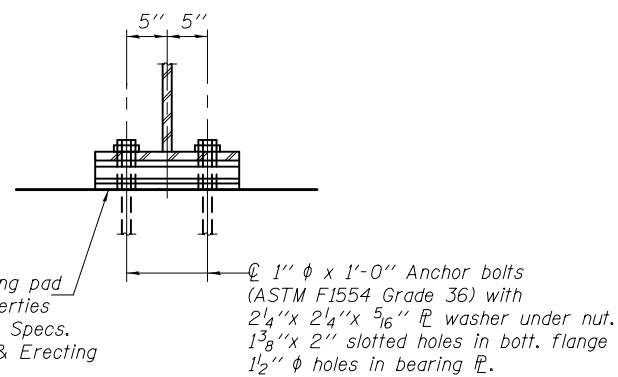

SECTION A-A

ABUTMENT BEARING
(22 Required)

SHIM LOCATION

	W. Abut.	E. Abut.
Girder 6	3/8"	
Girder 6		3/8"

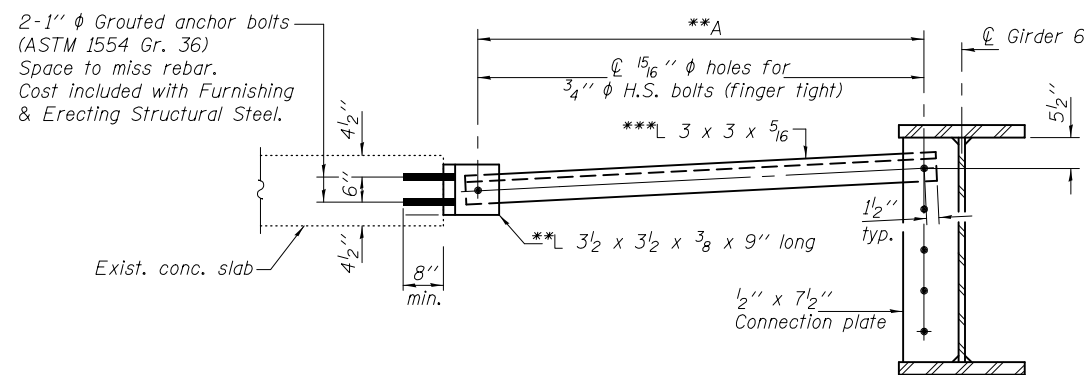

TEMPORARY BRACING FOR STAGE I CONSTRUCTION
(3 Required)

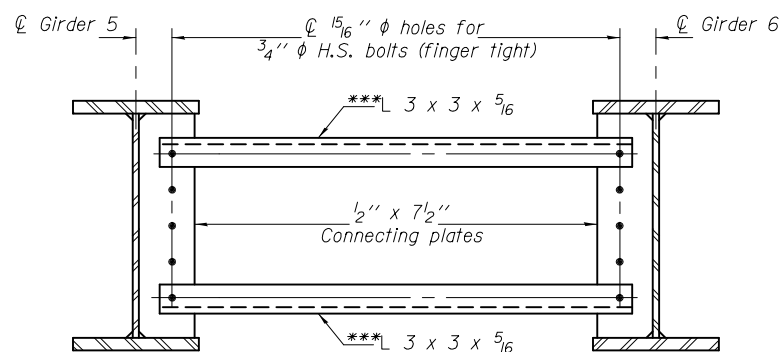

TEMPORARY BRACING FOR STAGE II CONSTRUCTION
(3 Required)

INTERIOR GIRDER MOMENT TABLE		0.5 Span
I_s	(in ⁴)	15336
$I_c(n)$	(in ⁴)	32054
$I_c(3n)$	(in ⁴)	23518
S_s	(in ³)	959
$S_c(n)$	(in ³)	1229
$S_c(3n)$	(in ³)	1121
DC1	(k/')	1.016
MDC1	(k)	1014
DC2	(k/')	0.150
MDC2	(k)	147
DW	(k/')	0.346
MDW	(k)	339
$M_{\frac{1}{2} + 1M}$	(k)	1331
M_u (Strength I)	(k)	4289
$\phi_r M_n$	(k)	5409
f_s DC1	(ksi)	12.7
f_s DC2	(ksi)	1.6
f_s DW	(ksi)	3.6
f_s ($\frac{1}{2} + 1M$)	(ksi)	13.0
f_s (Service II)	(ksi)	34.8
$0.95R_h F_y f$	(ksi)	47.5
V_r	(k)	52.4

INTERIOR GIRDER REACTION TABLE		Abuts.
R_{DC1}	(k)	45.8
R_{DC2}	(k)	6.6
R_{DW}	(k)	15.3
$R_{\frac{1}{2} + 1M}$	(k)	84.0
R_{Total}	(k)	151.7

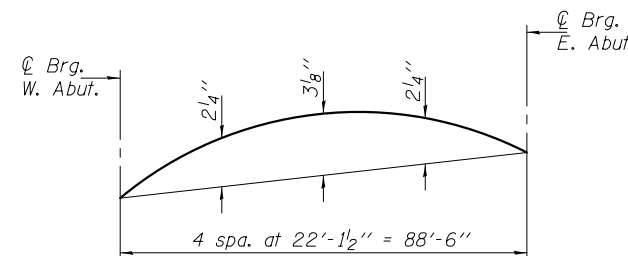

CAMBER DIAGRAM

I_s, S_s : Non-composite moment of inertia and section modulus of the steel section used for computing f_s (Total-Strength I, and Service II) due to non-composite dead loads (in⁴ and in³).

$I_c(n), S_c(n)$: Composite moment of inertia and section modulus of the steel and deck based upon the modular ratio, "n", used for computing f_s (Total-Strength I, and Service II) in uncracked sections due to short-term composite live loads (in⁴ and in³).

$I_c(3n), S_c(3n)$: Composite moment of inertia and section modulus of the steel and deck based upon 3 times the modular ratio, "3n", used for computing f_s (Total-Strength I, and Service II) in uncracked sections, due to long-term composite (superimposed) dead loads (in⁴ and in³).

DC1: Un-factored non-composite dead load (kips/ft.).

MDC1: Un-factored moment due to non-composite dead load (kip-ft.).

DC2: Un-factored long-term composite (superimposed excluding future wearing surface) dead load (kips/ft.).

MDC2: Un-factored moment due to long-term composite (superimposed excluding future wearing surface) dead load (kip-ft.).

DW: Un-factored long-term composite (superimposed future wearing surface only) dead load (kips/ft.).

MDW: Un-factored moment due to long-term composite (superimposed future wearing surface only) dead load (kip-ft.).

$M_{\frac{1}{2} + 1M}$: Un-factored live load moment plus dynamic load allowance (impact) (kip-ft.).

M_u (Strength I): Factored design moment (kip-ft.).

$1.25 (M_{DC1} + M_{DC2}) + 1.5 M_{DW} + 1.75 M_{\frac{1}{2} + 1M}$

$\phi_r M_n$: Compact composite positive moment capacity computed according to Article 6.10.7.1 or non-slender negative moment capacity according to Article A6.1.1 or A6.1.2 (kip-ft.).

f_s DC1: Un-factored stress at edge of flange for controlling steel flange due to vertical non-composite dead loads as calculated below (ksi).

M_{DC1} / S_{nc}

f_s DC2: Un-factored stress at edge of flange for controlling steel flange due to vertical composite dead loads as calculated below (ksi).

$M_{DC2} / S_c(3n)$ or $M_{DC2} / S_c(cr)$ as applicable.

f_s DW: Un-factored stress at edge of flange for controlling steel flange due to vertical composite future wearing surface loads as calculated below (ksi).

$M_{DW} / S_c(3n)$ or $M_{DW} / S_c(cr)$ as applicable.

f_s ($\frac{1}{2} + 1M$): Un-factored stress at edge of flange for controlling steel flange due to vertical composite live load plus impact loads as calculated below (ksi).

$M_{\frac{1}{2} + 1M} / S_c(n)$ or $M_{DW} / S_c(cr)$ as applicable.

f_s (Service II): Sum of stresses as computed below (ksi).

$f_{sDC1} + f_{sDC2} + f_{sDW} + 1.3 f_s (\frac{1}{2} + 1M)$

$0.95R_h F_y f$: Composite stress capacity for Service II loading according to Article 6.10.4.2 (ksi).

V_r : Maximum factored shear range in span computed according to Article 6.10.10.

Notes:

Anchor bolts shall be ASTM F1554 all-thread (or an Engineer-approved alternate material) of the grade(s) and diameter(s) specified. ASTM A307 Grade C anchor bolts may be used in lieu of ASTM F1554 Grade 36 (Fy=36ksi). The corresponding specified grade of AASHTO M314 anchor bolts may be used in lieu of ASTM F1554.

Anchor bolts at fixed bearings may be either cast in place or installed in holes drilled after the supported member is in place.

Drilled and set anchor bolts shall be installed according to Article 521.06 of the Standard Specifications.

Two hardened washers required for each set of oversized holes.

**The horizontal dimension A between the holes in the diaphragm connection plate and L 3 1/2 x 3 1/2 shall be measured in the field. The holes in the L 3 1/2 x 3 1/2 shall be field drilled at this dimension. Cost included with Furnishing & Erecting Structural Steel.

***L 3 x 3 x 5/16 to be used as temporary during Stage I and Stage II deck pour. Remove and replace with diaphragm D after Stage II deck pour is complete. Use between Girders 5 & 6 only. Cost included with Furnishing & Erecting Structural Steel.

***TOP OF WEB ELEVATIONS**

	℄ Brg. W. Abut.	℄ Brg. E. Abut.
Girder 1	574.50	574.95
Girder 2	574.64	575.09
Girder 3	574.75	575.19
Girder 4	574.86	575.30
Girder 5	574.97	575.41
Girder 6	575.00	575.44
Girder 7	574.89	575.33
Girder 8	574.76	575.20
Girder 9	574.62	575.06
Girder 10	574.47	574.92
Girder 11	574.33	574.77

*For fabrication use only.

DESIGNED - STEPHEN M. RYAN
CHECKED - RAY AHANCHI
DRAWN - h.t. duong
CHECKED - S.M.R. / G.R.A.

EXAMINED
PASSED
ACTING ENGINEER OF BRIDGES AND STRUCTURES

DATE - MARCH 12, 2013
REVISED
REVISED

STATE OF ILLINOIS
DEPARTMENT OF TRANSPORTATION

STRUCTURAL STEEL DETAILS
STRUCTURE NO. 081-0163

SHEET NO. 24 OF 30 SHEETS

F.A.U. RTE.	SECTION	COUNTY	TOTAL SHEETS	SHEET NO.
5789	40 BR	ROCK ISLAND	225	145

CONTRACT NO. 64341
ILLINOIS FED. AID PROJECT