

GUTTER OUTLET ADJACENT TO STABILIZED SHOULDER

NOTE:
IF THE AVERAGE GRADE OF PAVEMENT FOR THE DISTANCE A-C EXCEEDS 2%, THIS DISTANCE SHALL BE INCREASED 6" FOR EACH 1% INCREASE IN GRADE.
3 % 30' 2.93 CU. YD.
4 % 36' 3.51 CU. YD.
5 % 42' 4.10 CU. YD.
6 % 48' 4.68 CU. YD.

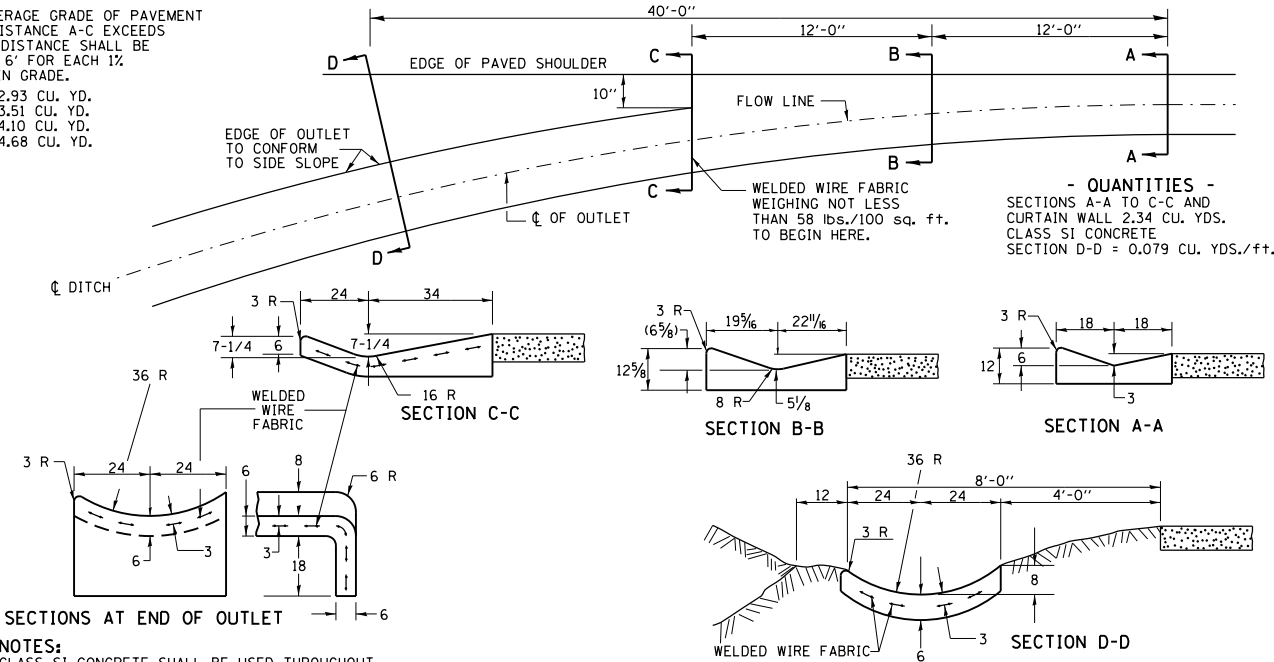

- QUANTITIES -
SECTIONS A-A TO C-C AND CURTAIN WALL 2.34 CU. YDS.
CLASS SI CONCRETE
SECTION D-D = 0.079 CU. YDS./FT.

NOTES:
CLASS SI CONCRETE SHALL BE USED THROUGHOUT.
THE GUTTER OUTLET WILL BE PAID FOR AT THE CONTRACT UNIT PRICE PER CU. YD. FOR CLASS SI CONCRETE (OUTLETS), WHICH PRICE SHALL INCLUDE THE COST OF THE WELDED WIRE FABRIC REINFORCEMENT

REVISED - 9-30-11

GUTTER OUTLET ADJACENT TO STABILIZED SHOULDER 15.4

GRADING AROUND WINGWALLS

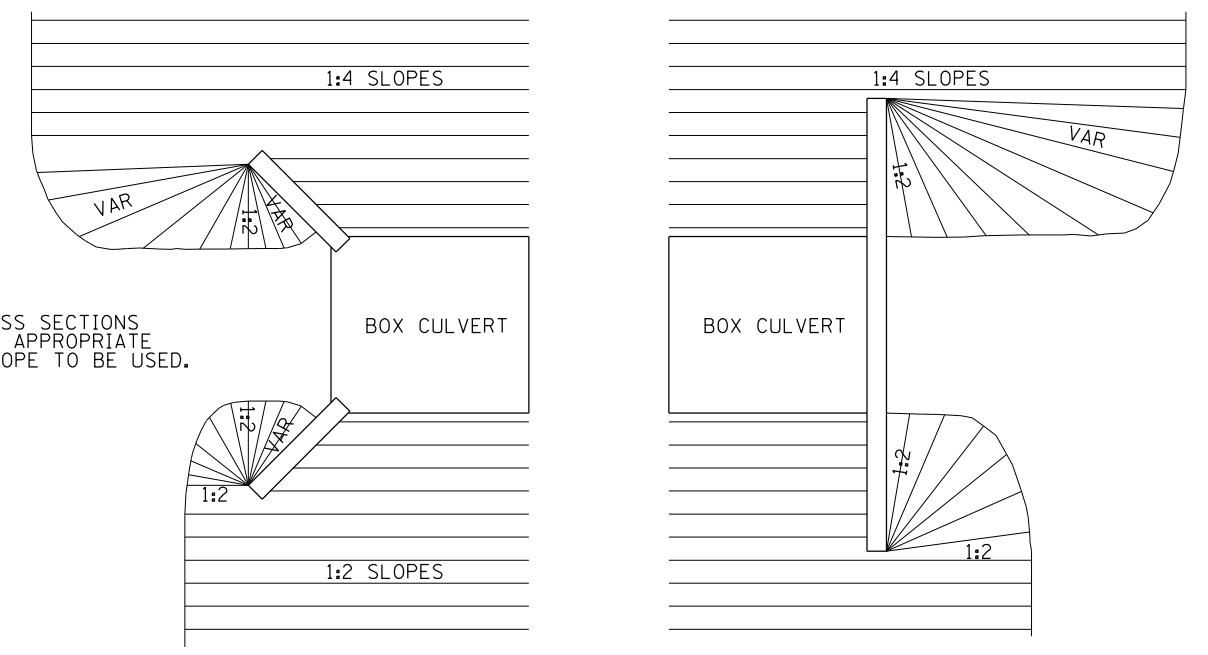

NOTES
SEE CROSS SECTIONS FOR THE APPROPRIATE FRONTSLOPE TO BE USED.

5-27-09

GRADING AROUND WINGWALLS 20.4

DETAIL OF HOT-MIX ASPHALT SHOULDER AT GUARD RAIL

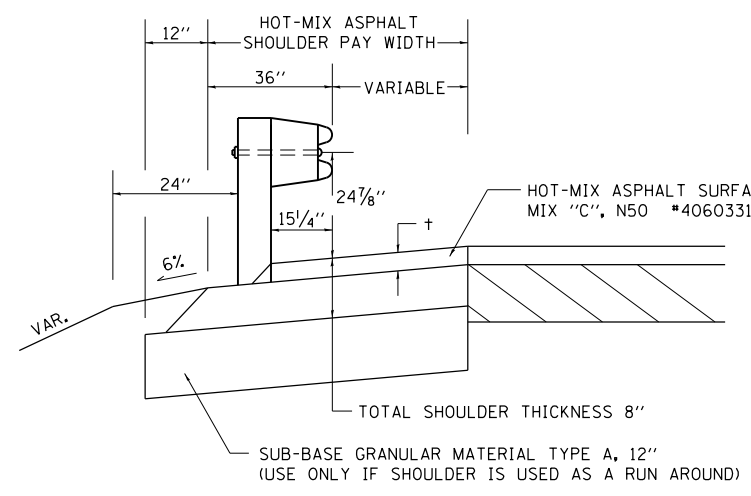

† = SEE TYPICAL SECTIONS FOR THICKNESS

GENERAL NOTES

THE TOP LIFT SHALL NOT BE PLACED BEHIND THE GUARDRAIL POSTS. WHEN PLACING THE TOP LIFT THE RAIL MUST BE REMOVED FROM THE POSTS. THE POST SHALL NOT BE REMOVED.
THE HEIGHT OF THE GUARD RAIL SHALL BE SET 24 7/8" FROM THE FINISHED SURFACE.
THE HOT-MIX ASPHALT SHOULDER SHALL BE CONSTRUCTED IN ACCORDANCE WITH SECTION 482 EXCEPT THE TOP LIFT SHALL BE HOT-MIX ASPHALT SURFACE COURSE, MIXTURE C, N50. THE WORK WILL BE PAID FOR AT THE CONTRACT UNIT PRICE PER TON FOR HOT-MIX ASPHALT SURFACE COURSE, MIXTURE "C", N50 AND SQUARE YARD FOR HOT-MIX ASPHALT SHOULDERS OF THE THICKNESS SPECIFIED. THE REMOVAL & REINSTALLATION OF THE GUARDRAIL WILL BE INCLUDED IN THE COST OF THE HOT-MIX ASPHALT SURFACE COURSE, MIXTURE C, N50.

REVISED - 6-06-11

DETAIL OF HOT-MIX ASPHALT SHOULDER AT GUARD RAIL 23.4

HOT-MIX ASPHALT SHOULDER

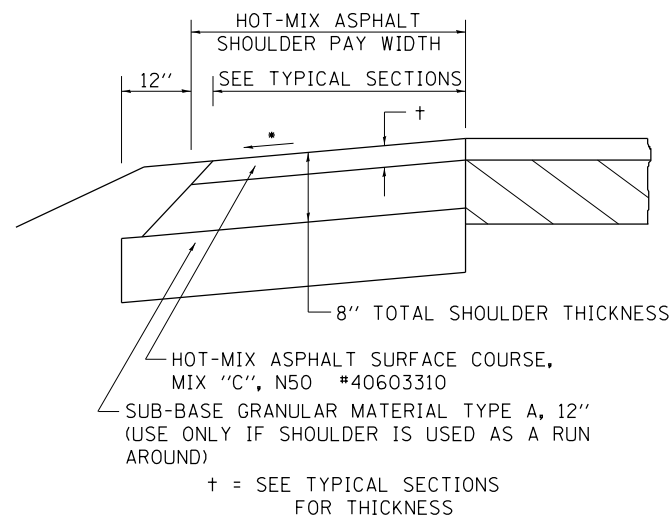

GENERAL NOTES

THE HOT-MIX ASPHALT SHOULDER SHALL BE CONSTRUCTED IN ACCORDANCE WITH SECTION 482 EXCEPT THE TOP LIFT SHALL BE HOT-MIX ASPHALT SURFACE COURSE, MIX "C", N50 #40603310. THE WORK WILL BE PAID FOR AT THE CONTRACT UNIT PRICE PER TON FOR HOT-MIX ASPHALT SURFACE COURSE, MIX "C", N50 #40603310 AND SQUARE YARD FOR HOT-MIX ASPHALT SHOULDERS OF THE THICKNESS SPECIFIED.

USE HOT-MIX ASPHALT SURFACE COURSE, MIX "C", N50 #40603310. WHEN RESURFACING EXISTING HOT-MIX ASPHALT SHOULDERS. THE THICKNESS IS SHOWN ON THE TYPICAL SECTIONS. THIS WORK WILL BE PAID FOR AT THE CONTRACT UNIT PRICE PER TON FOR HOT-MIX ASPHALT SURFACE COURSE, MIX "C", N50 #40603310.

REMOVAL OF MATERIAL FOR PLACEMENT OF THE HOT-MIX ASPHALT SHOULDER TO BE PAID FOR IN UNITS FOR EXCAVATING AND GRADING EXISTING SHOULDERS OR IN CUBIC YARDS FOR EARTH EXCAVATION OR EARTH EXCAVATION WIDENING.

* 4% WHEN MAINLINE IS ON TANGENT. FOR CROSS SLOPE ON SUPERELEVATION SECTION, SEE HIGHWAY STANDARD 482001 OR 482006.

† = SEE TYPICAL SECTIONS FOR THICKNESS

REVISED - 6-06-11	REGION 2 / DISTRICT 2 STANDARD				F.A.U. RTE.	SECTION	COUNTY	TOTAL SHEETS	SHEET NO.
REVISED -					5789	40BR	ROCK ISLAND	225	152
REVISED -					CONTRACT NO. 64341				
REVISED -	SCALE: 40,0000 ' / 1"	SHEET NO.	OF SHEETS	STA.	TO STA.		FED. ROAD DIST. NO.		ILLINOIS FED. AID PROJECT

HOT-MIX ASPHALT SHOULDER 23.4a