

ENTRANCE APPROACHES – URBAN AREA

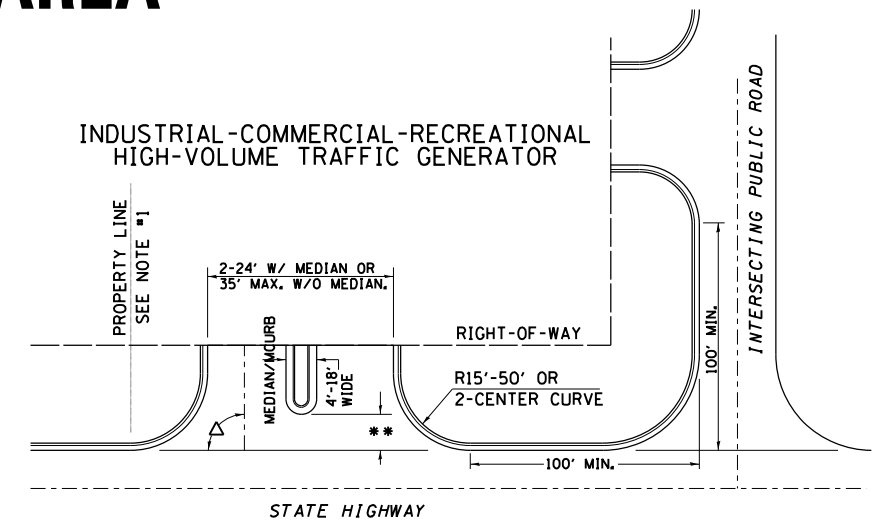
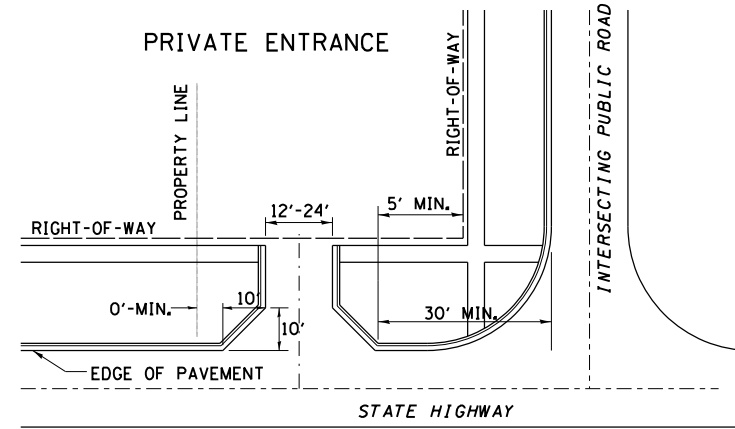
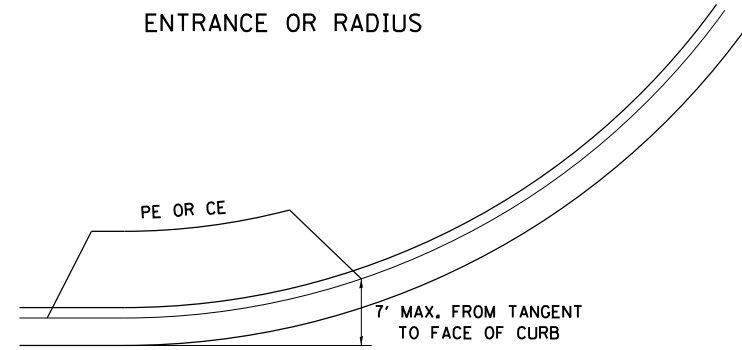

A MINIMUM OF 440 FEET SHALL BE MAINTAINED BETWEEN CENTER LINES OF ADJACENT DRIVEWAYS.
 Δ 90° DESIRABLE, 45° MIN. ANGLE PERMITTED ONLY FOR ONE-WAY DRIVEWAYS.
 60° MIN. ANGLE FOR TWO-WAY DRIVEWAYS.

NOTE: #1 ENCROACHMENT ON THE ADJACENT PROPERTY OWNER LAND REQUIRES HIS OR HER WRITTEN APPROVAL.

** 4'-10' IF HIGHWAY CURBED.
 AT EDGE OF SHOULDER IF HIGHWAY UNCURBED.

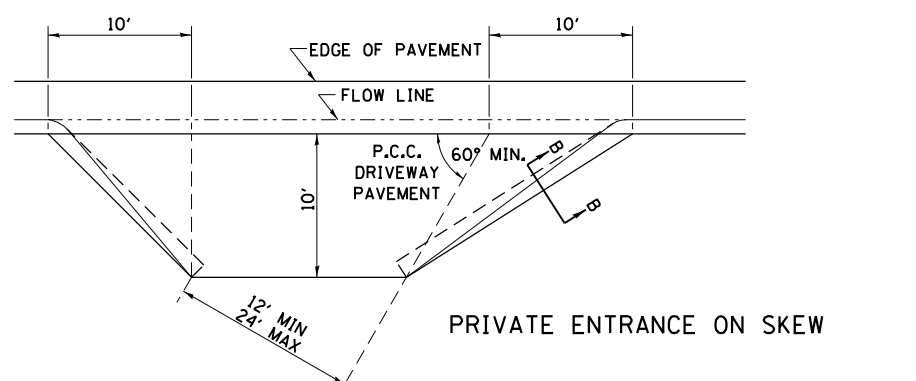
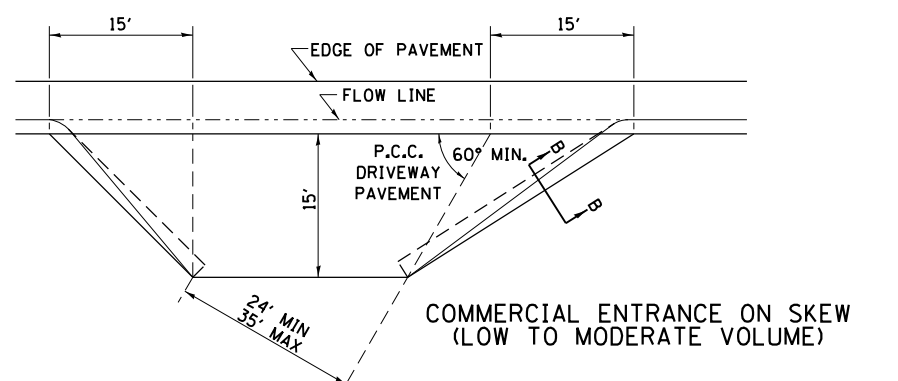
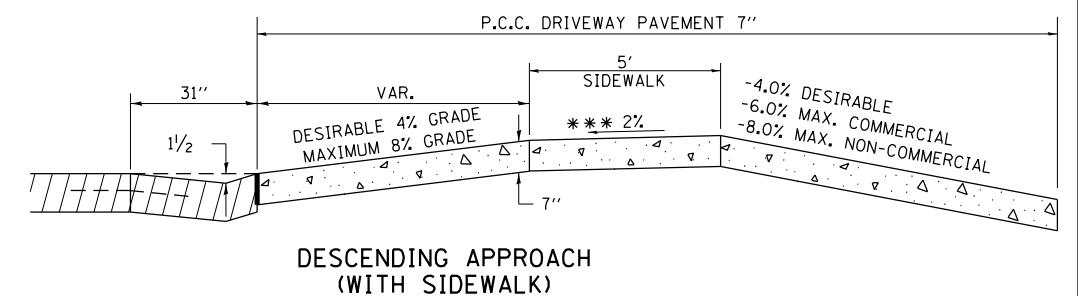
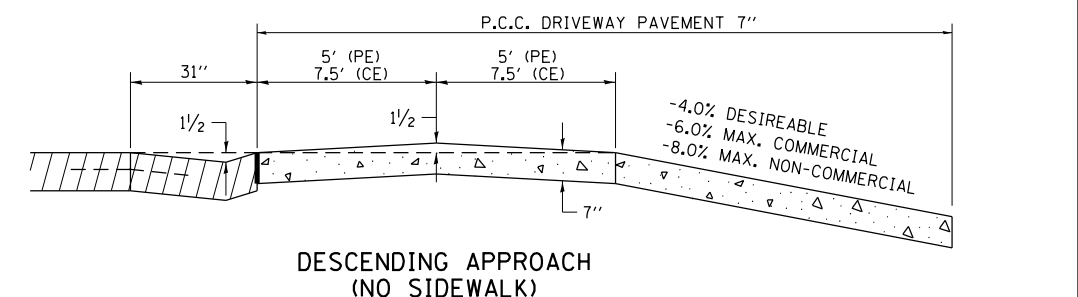
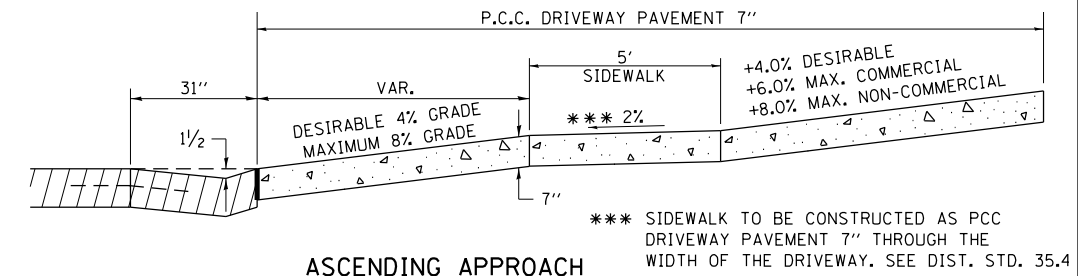
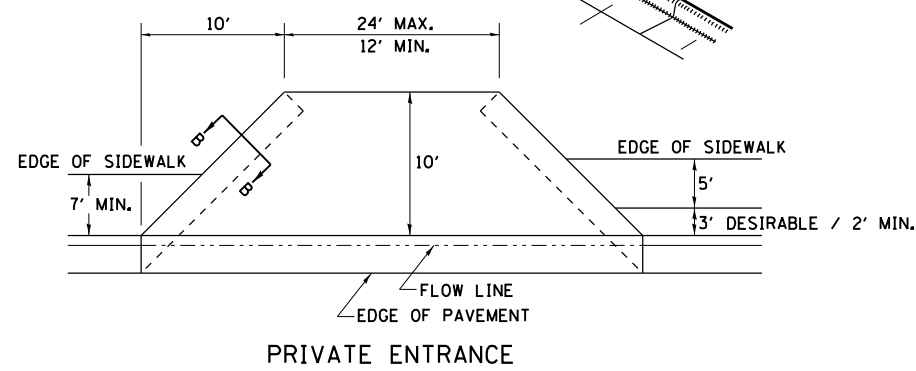
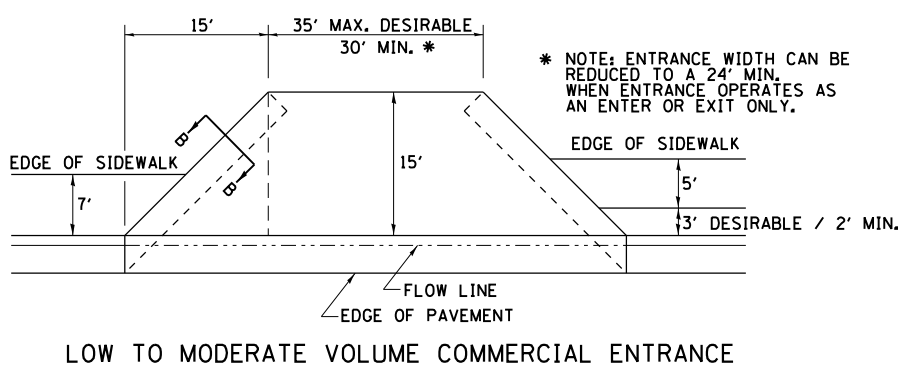
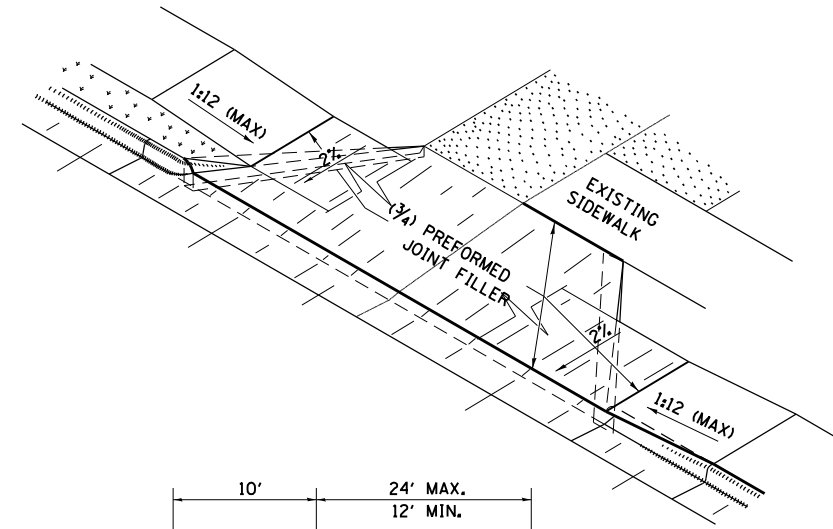
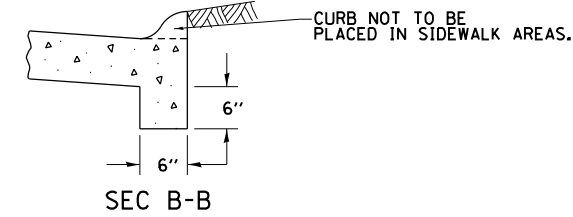

NOTE: CURVED ENTRANCE RETURNS MAY BE USED FOR LOW TO MODERATE VOLUME LOCATIONS WITH REVIEW ON A CASE-BY-CASE BASIS.

FILE NAME =	USER NAME = renkesw	DESIGNED -	REVISED - 12-07-10
ct:\pwork\pwork\renkesw\dms36691\020584-sht-details.dgn		DRAWN -	REVISED -
		CHECKED -	REVISED -
		DATE -	REVISED -

**STATE OF ILLINOIS
 DEPARTMENT OF TRANSPORTATION**

REGION 2 / DISTRICT 2 STANDARD			
SCALE:	SHEET NO.	OF SHEETS	STA. TO STA.

F.A.U. RTE.	SECTION	COUNTY	TOTAL SHEETS	SHEET NO.
5789	40BR	ROCK ISLAND	225	159
CONTRACT NO.			64341	
FED. ROAD DIST. NO. ILLINOIS FED. AID PROJECT				