

**STAGE I REMOVAL: SN 081-0195 (W.B.)**

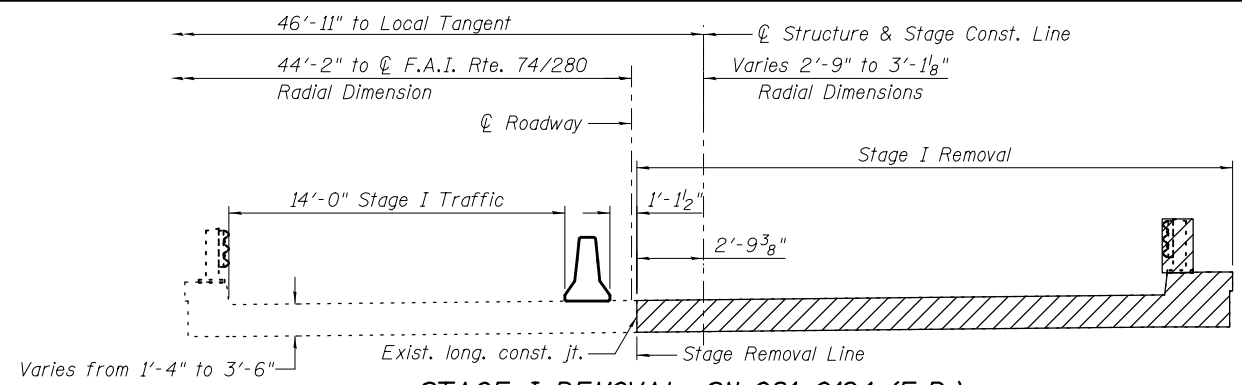

**STAGE I REMOVAL: SN 081-0194 (E.B.)**

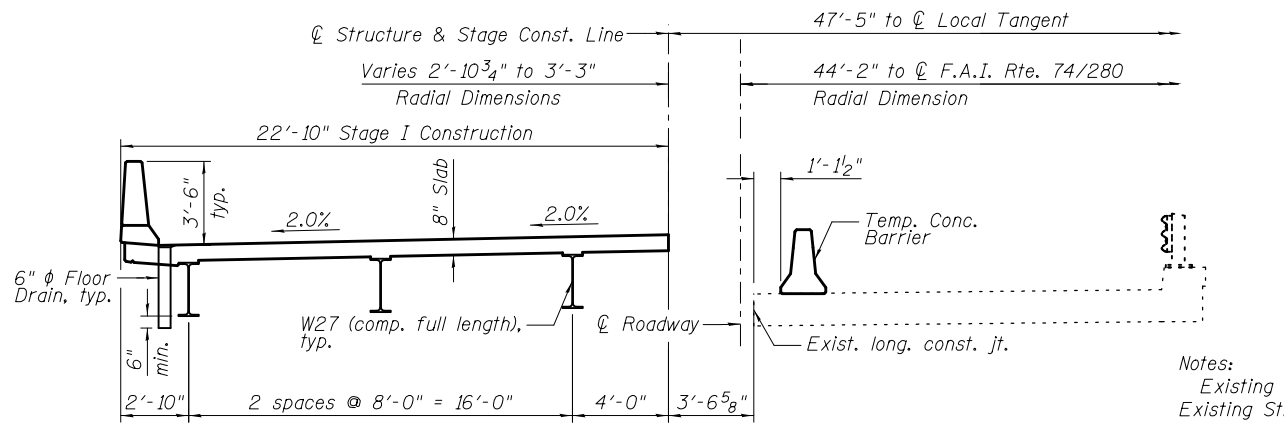

**STAGE I CONSTRUCTION: SN 081-0195 (W.B.)**

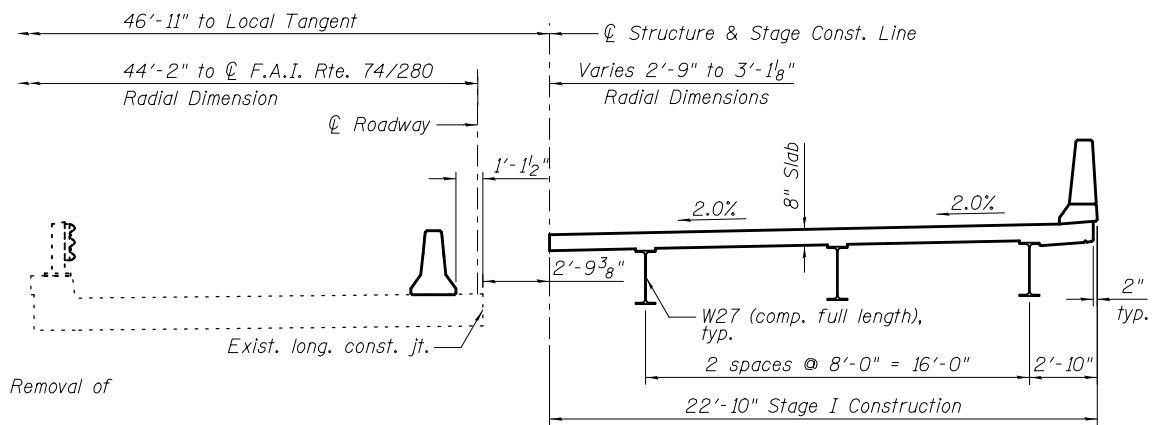

**STAGE I CONSTRUCTION: SN 081-0194 (E.B.)**

Notes:  
 Existing railing removal shall be included with Removal of Existing Structures.  
 Hatched areas indicate Removal of Existing Structures.  
 See roadway plans for quantity of Temporary Concrete Barrier.  
 See Sheet 6 of 38 for details of Temporary Concrete Barrier.  
 All staging cross sections are looking East.

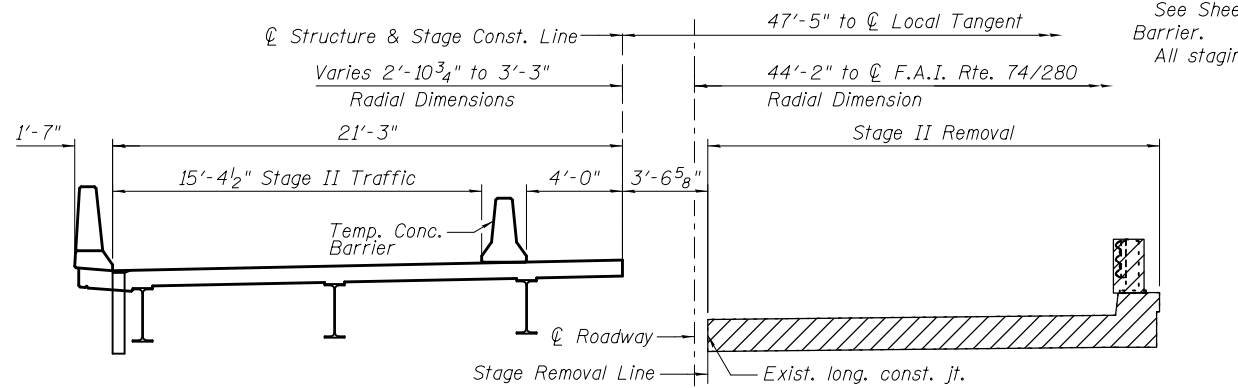

**STAGE II REMOVAL: SN 081-0195 (W.B.)**

(Looking East)

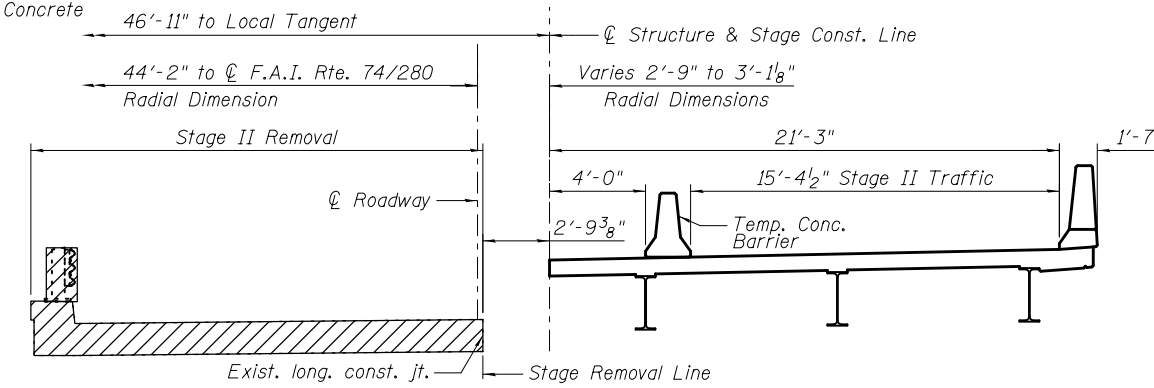

**STAGE II REMOVAL: SN 081-0194 (E.B.)**

(Looking East)

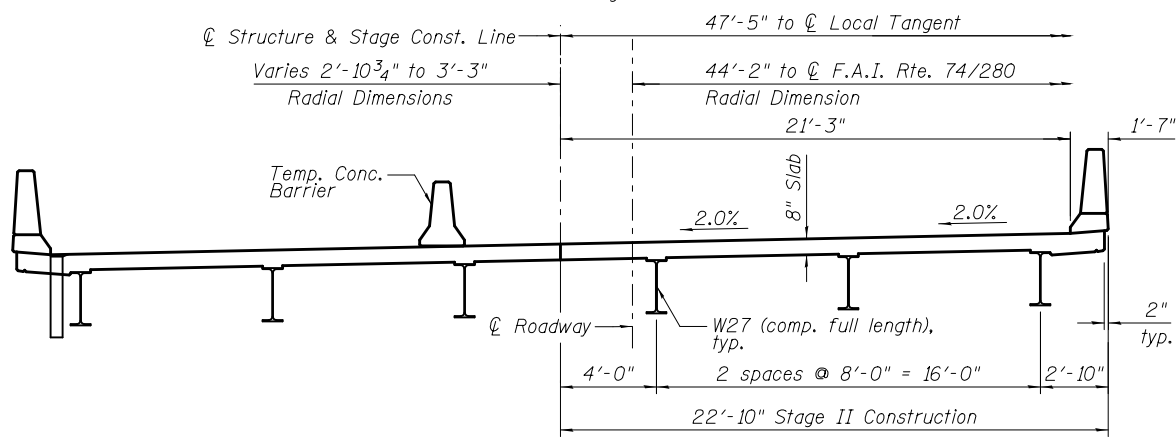

**STAGE II CONSTRUCTION: SN 081-0195 (W.B.)**

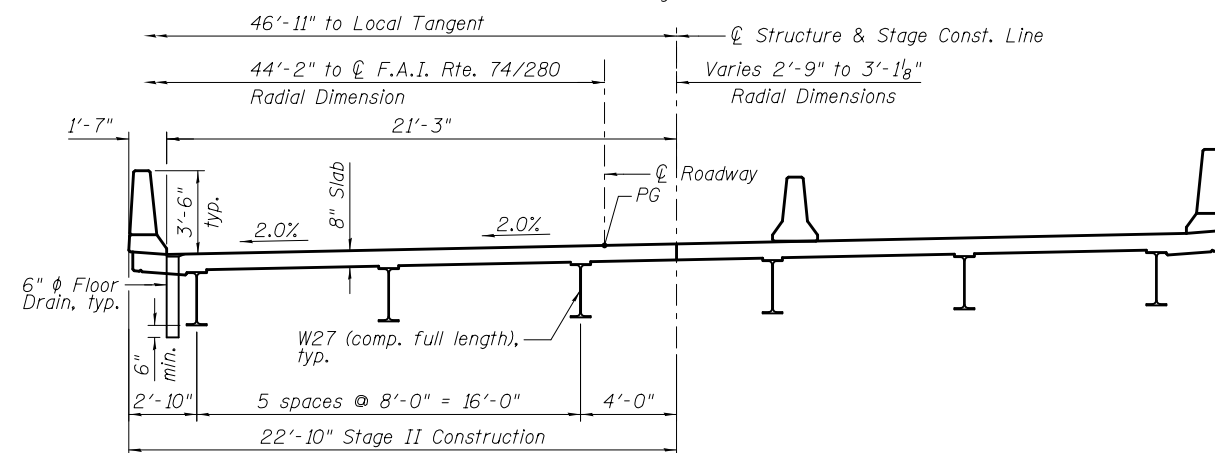

**STAGE II CONSTRUCTION: SN 081-0194 (E.B.)**

3/19/2013 2:41:55 PM 0810194\_64D23\_004\_Stageing.dgn



DESIGNED - MAS	REVISED -
CHECKED - BJM	REVISED -
DRAWN - MWS	REVISED -
CHECKED - BJM	REVISED -

STATE OF ILLINOIS  
DEPARTMENT OF TRANSPORTATION

STAGE CONSTRUCTION DETAILS  
STRUCTURE NO. 081-0194 (E.B.) & NO. 081-0195 (W.B.)

SHEET NO. 4 OF 38 SHEETS

F.A.I. RTE. 74/280	SECTION 81-3BR	COUNTY ROCK ISLAND	TOTAL SHEETS 290	SHEET NO. 167
CONTRACT NO. 64D23				
ILLINOIS FED. AID PROJECT				