

STATE OF ILLINOIS
DEPARTMENT OF TRANSPORTATION
DIVISION OF HIGHWAYS

**PROPOSED
HIGHWAY PLANS**

F.A.I. ROUTE 57 (I-57) & F.A.I. ROUTE 74 (I-74)
SECTION D5 PATCHING 2013-5
PAVEMENT PATCHING
CHAMPAIGN & VERMILION COUNTIES

C-95-033-12

F.A.I. RTE.	SECTION	COUNTY	TOTAL SHEETS	SHEET NO.
57&74	D5 PATCHING 2013-5	ILLINOIS	24	1

CONTRACT NO. 70986
• CHAMPAIGN & VERMILION

FOR LOCATION MAPS, SEE SHEETS NO. 2-4
FOR INDEX OF SHEETS, SEE SHEET NO. 5
FOR SUMMARY OF QUANTITIES, SEE SHEETS NO. 6-8

CURRENT ADT OTHER PRINCIPAL ARTERIAL FAI 57 (I-57)			
LEG "A"	ADT(2013) = 21,800	SU = 4.3%	MU = 25.9%
LEG "B"	ADT(2013) = 23,700	SU = 3.3%	MU = 24.3%
LEG "C"	ADT(2013) = 33,600	SU = 3.9%	MU = 24.5%
LEG "D"	ADT(2013) = 23,000	SU = 4.4%	MU = 23.8%
LEG "E"	ADT(2013) = 20,400	SU = 3.2%	MU = 24.6%
LEG "F"	ADT(2013) = 21,400	SU = 3.2%	MU = 24.4%

OTHER PRINCIPAL ARTERIAL FAI 74 (I-74)			
LEG "A"	ADT(2013) = 27,800	SU = 3.5%	MU = 23.0%
LEG "B"	ADT(2013) = 27,500	SU = 3.6%	MU = 21.1%
LEG "C"	ADT(2013) = 30,000	SU = 3.5%	MU = 23.2%
LEG "D"	ADT(2013) = 26,400	SU = 4.2%	MU = 24.8%
LEG "E"	ADT(2013) = 24,700	SU = 3.8%	MU = 26.5%
LEG "F"	ADT(2013) = 24,100	SU = 3.1%	MU = 24.2%
LEG "G"	ADT(2013) = 17,800	SU = 3.6%	MU = 35.1%
LEG "H"	ADT(2013) = 23,100	SU = 3.4%	MU = 29.1%

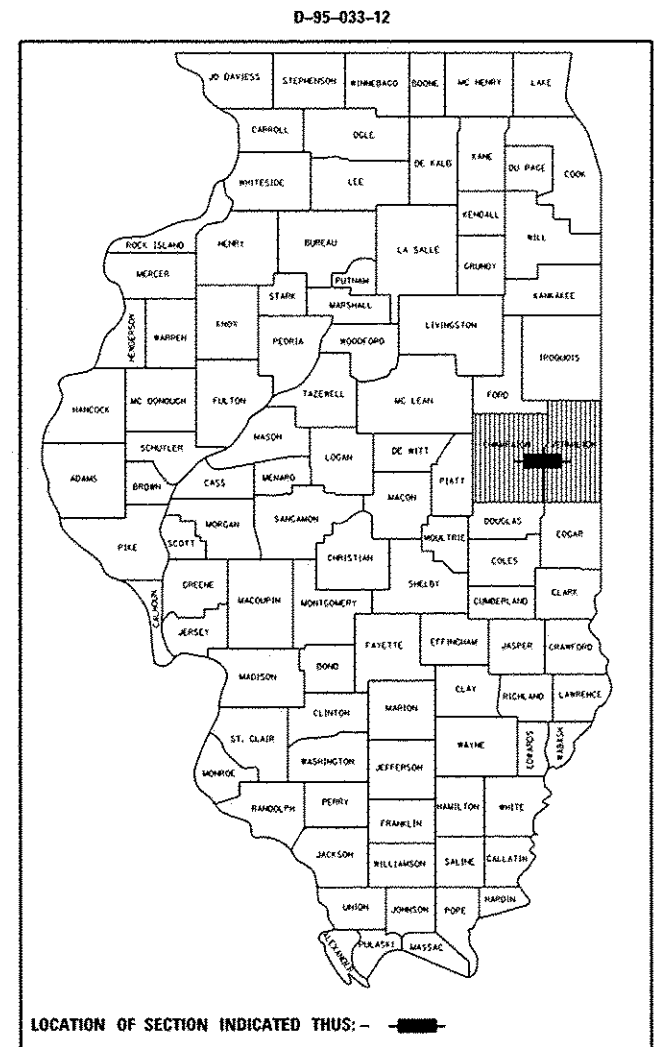

- LOCATION NO. 1 (F.A.I. 57) ON PAGE NO. 2
- LOCATION NO. 2 (F.A.I. 74) ON PAGE NO. 3
- LOCATION NO. 3 (F.A.I. 74) ON PAGE NO. 4

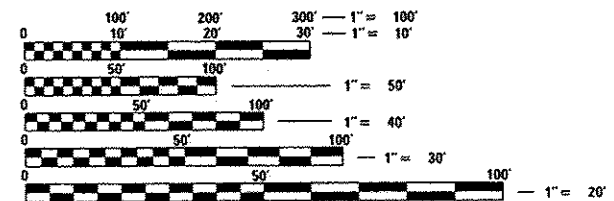

FULL SIZE PLANS HAVE BEEN PREPARED USING STANDARD ENGINEERING SCALES. REDUCED SIZED PLANS WILL NOT CONFORM TO STANDARD SCALES. IN MAKING MEASUREMENTS ON REDUCED PLANS, THE ABOVE SCALES MAY BE USED.

J.U.L.I.E.
JOINT UTILITY LOCATION INFORMATION FOR EXCAVATION
1-800-892-0123 TOWNSHIPS: CATLIN, CHAMPAIGN, HENSLEY,
OR 811 MAHOMET, OGDEN, SOMER, ST. JOSEPH,
TOLONO, & URBANA

PROJECT ENGINEER: NANCY FASIG
SQUAD LEADER: STEVE COOMBES
DESIGNER: DEREK BRIDGES
(217) 465-4181
CONTRACT NO. 70986

GROSS LENGTH = 246,351.13 FT. = 46.657 MILES
NET LENGTH = 246,351.13 FT. = 46.657 MILES

STATE OF ILLINOIS
DEPARTMENT OF TRANSPORTATION
DIVISION OF HIGHWAYS

SUBMITTED JAN 31 2013
Joseph E. Crowe
DEPUTY DIRECTOR OF HIGHWAYS, REGION ENGINEER

March 22 2010
John D. Baranzelli, PE, LE
ENGINEER OF DESIGN AND ENVIRONMENT

March 22 2010
Omer Osman, PE, LE
DIRECTOR OF HIGHWAYS, CHIEF ENGINEER

PRINTED BY THE AUTHORITY
OF THE STATE OF ILLINOIS

LOCATION NO. 1 - F.A.I. 57 (I-57)

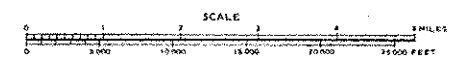
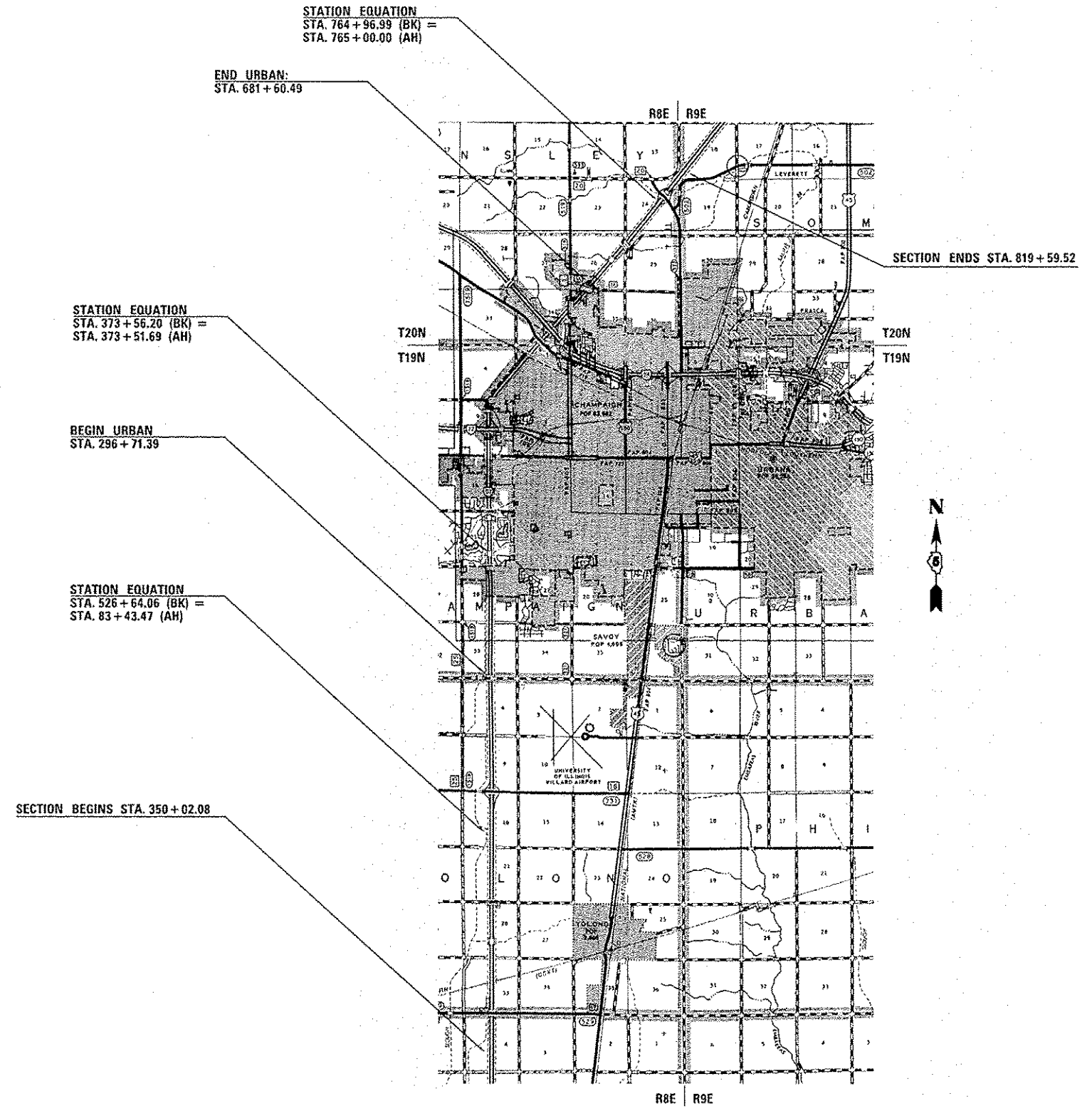

• CHAMPAIGN & VERMILION

FILE NAME :	USER NAME : qoombessf	DESIGNED -	REVISED -
c:\pwwork\p\dos\qoombessf\d032950\1\0986.sht-cover.dgn		DRAWN -	REVISED -
		CHECKED -	REVISED -
		DATE -	REVISED -
MODELNAME:	PLOT DATE : 1/31/2013		

STATE OF ILLINOIS
DEPARTMENT OF TRANSPORTATION

LOCATION MAP

SCALE: SHEET OF SHEETS STA. TO STA.

F.A.I. RTE.	SECTION	COUNTY	TOTAL SHEETS	SHEET NO.
57&74	DS PATCHING 2013-5		24	2
CONTRACT NO. 70986				
ILLINOIS FED. AID PROJECT				

SECTION BEGINS STA. 1517 + 53.78

LOCATION NO. 2 - F.A.I. 74 (I-74)

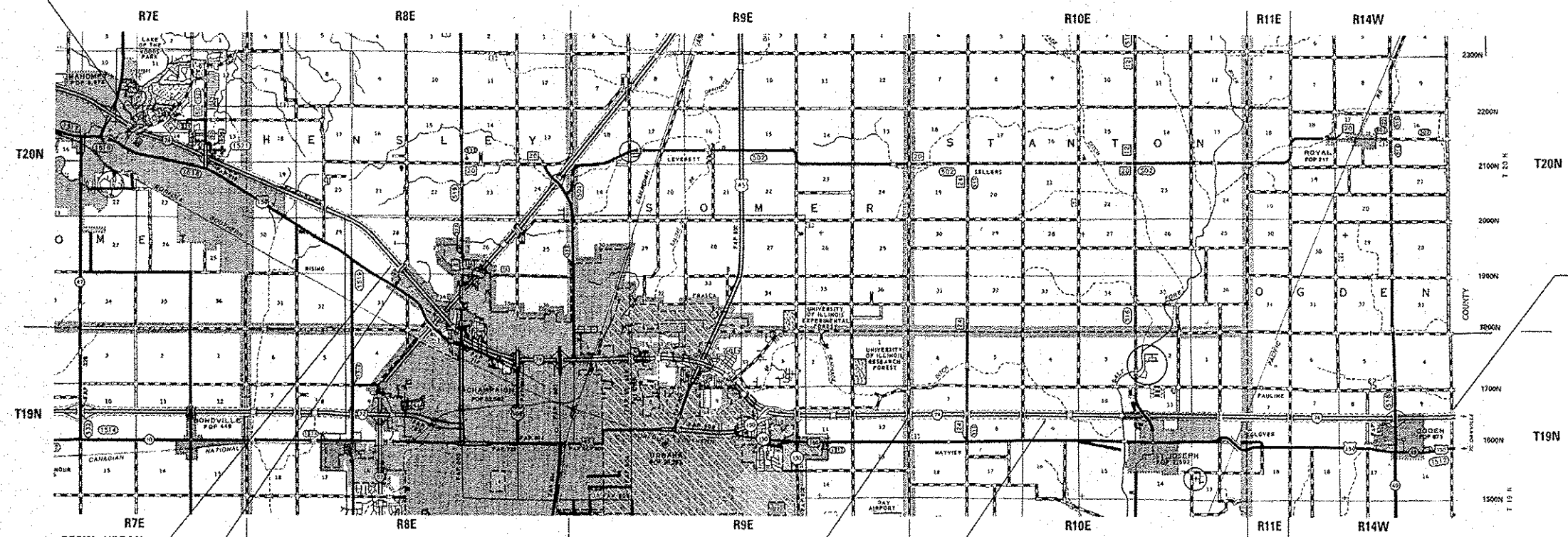

CHAMPAIGN / VERMILION
COUNTY LINE STA. 1053 + 06

BEGIN URBAN
STA. 1808 + 09.62

SECTION ENDS STA. 1819 + 18.42

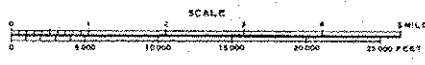

END URBAN
STA. 2318 + 14.42

SECTION BEGINS STA. 688 + 21.60



FILE NAME = c:\pwwork\pwwork\comboss\10329504\10329504.dwg USER NAME = comboss DESIGNED - DRAWN - CHECKED - DATE - PLOT SCALE = 48,0000 / 1 in. PLOT DATE = 11/31/2013				REVISIONS REVISION NO. DATE DESCRIPTION - - - - - - - - - - - -				STATE OF ILLINOIS DEPARTMENT OF TRANSPORTATION				LOCATION MAP				F.A.I. RTE. 57&74 SECTION DS PATCHING 2013-5 COUNTY * TOTAL SHEETS 24 SHEET NO. 3 CONTRACT NO. 70986	
SCALE: _____								SHEET _____ OF _____ SHEETS		STA. _____ TO STA. _____		ILLINOIS FED. AID PROJECT					

• CHAMPAIGN & VERMILION

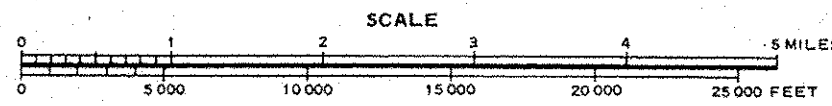
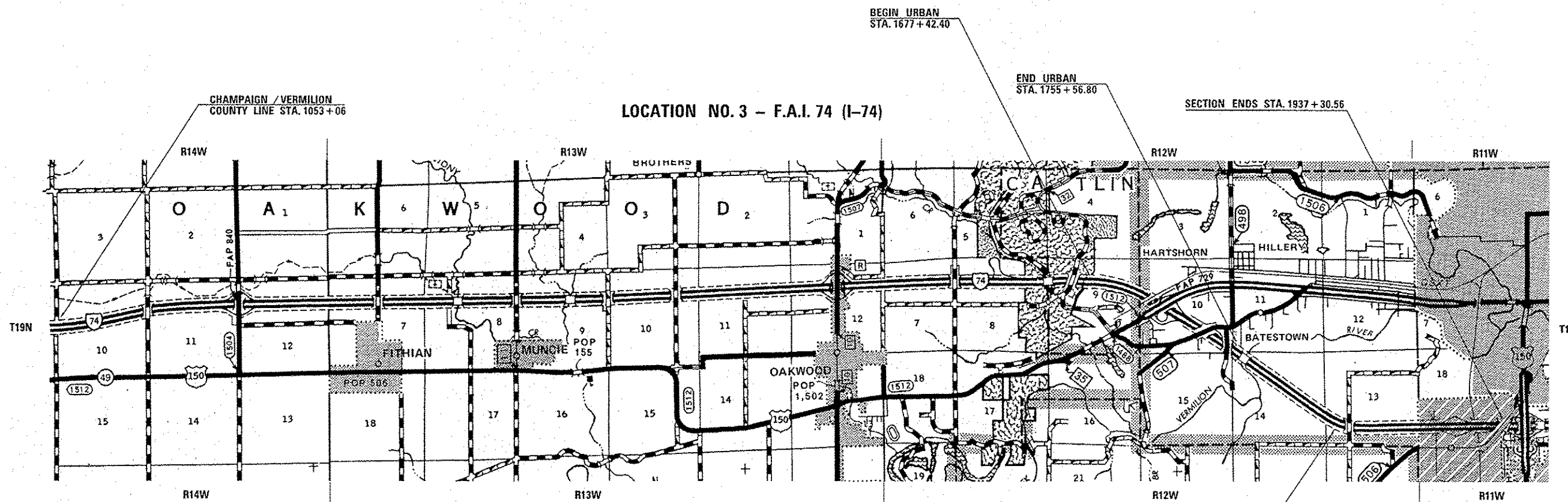

BEGIN URBAN
STA. 1853+77.60

• CHAMPAIGN & VERMILION

FILE NAME	USER NAME = coombesf	DESIGNED -	REVISED -
c:\pwork\pvidot\coombesf\d0329504\d070986-ah-cover.dgn		DRAWN -	REVISED -
		CHECKED - 48.0880 / /	REVISED -
MODEL NAME	PLOT DATE = 1/31/2013	DATE -	REVISED -

STATE OF ILLINOIS
DEPARTMENT OF TRANSPORTATION

LOCATION MAP			
SCALE:	SHEET	OF SHEETS	STA. TO STA.

F.A.I. RTE.	SECTION	COUNTY	TOTAL SHEETS	SHEET NO.
57&74	05 PATCHING 2013-5		24	4
CONTRACT NO. 70986				
ILLINOIS FED. AID PROJECT				

INDEX OF SHEETS

SHEET NO.	DESCRIPTION
1	COVER SHEET
2-4	LOCATION MAPS
5	INDEX OF SHEETS & LIST OF HIGHWAY STANDARDS
5	GENERAL NOTES
6-8	SUMMARY OF QUANTITIES
9-16	EXISTING TYPICAL CROSS SECTIONS
17-24	SCHEDULE OF QUANTITIES

LIST OF HIGHWAY STANDARDS

STANDARD NO.	DESCRIPTION
000001-06	STANDARD SYMBOLS, ABBREVIATIONS AND PATTERNS
001001-02	AREAS OF REINFORCEMENT BARS
001006	DECIMAL OF AN INCH AND OF A FOOT
420001-07	PAVEMENT JOINTS
421001-02	BAR REINFORCEMENT FOR CRC PAVEMENT
442001-04	CLASS A PATCHES
442101-07	CLASS B PATCHES
701101-03	OFF-ROAD OPERATIONS, MULTILANE, 15' (4.5 m) TO 24" (600 mm) FROM PAVEMENT EDGE
701400-06	APPROACH TO LANE CLOSURE, FREEWAY / EXPRESSWAY
701401-07	LANE CLOSURE, FREEWAY OR EXPRESSWAY
701411-08	LANE CLOSURE, MULTILANE, AT ENTRANCE OR EXIT RAMP, FOR SPEEDS • 45 MPH
701426-05	LANE CLOSURE, MULTILANE, INTERMITTENT OR MOVING OPER., FOR SPEEDS • 45 MPH
701901-02	TRAFFIC CONTROL DEVICES

GENERAL NOTES

G. N. -100
ENGLISH UNITS OF MEASUREMENT SHALL GOVERN OVER AND SUPERSEDE ANY METRIC UNITS SHOWN IN THIS CONTRACT. WHERE INCLUDED, METRIC UNITS ARE FOR INFORMATION ONLY.

G. N. -100A
ELECTRONIC FILES AND/OR ELECTRONIC SURVEY INFORMATION INCLUDING CADD FILES WILL NOT BE AVAILABLE TO THE CONTRACTOR.

G. N. -442B -- PATCHING SCHEDULES
THE PATCHING SCHEDULES INCLUDED IN THE PLANS REPRESENT THE BEST INFORMATION AVAILABLE AT THE TIME OF COMPLETION OF THE PLANS FOR LETTING. VARIATIONS IN LOCATION AND SIZES OF BOTH FULL-DEPTH AND PARTIAL-DEPTH PATCHES MAY OCCUR.

G. N. -1004.01
COARSE AGGREGATE GRADATION CA-10 MAY BE USED WHENEVER COARSE AGGREGATE CA-6 IS SPECIFIED IN THE STANDARD SPECIFICATIONS.

COMMITMENTS:
THERE ARE NO COMMITMENTS FOR THIS CONTRACT.

• CHAMPAIGN & VERMILION

FILE NAME *	USER NAME * coombessf	DESIGNED -	REVISED -	STATE OF ILLINOIS DEPARTMENT OF TRANSPORTATION	INDEX OF SHEETS, HIGHWAY STANDARDS, & GENERAL NOTES	F.A.I. RTE. 578.74	SECTION D5 PATCHING 2013-5	COUNTY •	TOTAL SHEETS 24	SHEET NO. 5						
<table border="1" style="width: 100%; border-collapse: collapse;"> <tr> <td style="width: 15%;">DRAWN -</td> <td style="width: 15%;">REVISED -</td> </tr> <tr> <td style="width: 15%;">CHECKED -</td> <td style="width: 15%;">REVISED -</td> </tr> <tr> <td style="width: 15%;">DATE -</td> <td style="width: 15%;">REVISED -</td> </tr> </table>				DRAWN -	REVISED -	CHECKED -	REVISED -	DATE -	REVISED -	SCALE: SHEET OF SHEETS STA. TO STA.		CONTRACT NO. 70986				
DRAWN -	REVISED -															
CHECKED -	REVISED -															
DATE -	REVISED -															
ILLINOIS FED. AID PROJECT																

SUMMARY OF QUANTITIES

LOCATION OF WORK:	FAI 57	FAI 57	FAI 74	FAI 74	FAI 74	FAI 74
	RURAL	URBAN	RURAL	URBAN	RURAL	URBAN
	INTERSTATE	INTERSTATE	INTERSTATE	INTERSTATE	INTERSTATE	INTERSTATE
	CHAMPAIGN COUNTY	CHAMPAIGN COUNTY	CHAMPAIGN COUNTY	CHAMPAIGN COUNTY	VERMILION COUNTY	VERMILION COUNTY
FUNDING BREAKOUT:	100 % STATE	100 % STATE	100 % STATE	100 % STATE	100 % STATE	100 % STATE
CONSTRUCTION TYPE CODE:	0005	0005	0005	0005	0005	0005

CODE NO.	ITEM	UNIT	TOTAL QUANTITY	QUANTITY	QUANTITY	QUANTITY	QUANTITY	QUANTITY	QUANTITY
44201053	CLASS B PATCHES, TYPE IV, 17 INCH	SQ YD	167.0	0.0	40.0	27.0	0.0	0.0	100.0
44201054	CLASS B PATCHES, TYPE I, 17 INCH	SQ YD	4.0	0.0	4.0	0.0	0.0	0.0	0.0
44201055	CLASS B PATCHES, TYPE II, 17 INCH	SQ YD	59.0	0.0	16.0	27.0	0.0	0.0	16.0
44201063	CLASS B PATCHES, TYPE II, 18 INCH	SQ YD	16.0	0.0	16.0	0.0	0.0	0.0	0.0
44201299	DOWEL BARS 1 1/2"	EACH	1566.0	370.0	526.0	198.0	0.0	280.0	192.0
44213000	PATCHING REINFORCEMENT	SQ YD	734.0	317.0	53.0	107.0	8.0	249.0	0.0
44213200	SAW CUTS	FOOT	7896.0	2,424.0	1,840.0	2,316.0	60.0	716.0	540.0
44213204	TIE BARS 3/4"	EACH	270.0	175.0	10.0	85.0	0.0	0.0	0.0
44213208	TIE BARS 1 1/4"	EACH	174.0	40.0	45.0	10.0	0.0	26.0	53.0
67100100	MOBILIZATION	L SUM	1.0	0.3	0.2	0.3	0.0	0.1	0.1
70100420	TRAFFIC CONTROL AND PROTECTION, STANDARD 701411	EACH	20.0	1.0	1.0	10.0	0.0	0.0	8.0
70100800	TRAFFIC CONTROL AND PROTECTION, STANDARD 701401	L SUM	1.0	0.3	0.2	0.3	0.0	0.1	0.1
70103815	TRAFFIC CONTROL SURVEILLANCE	CAL DA	20.0	6.0	4.0	5.5	1.0	2.0	1.5
X0323583	SPEED INDICATOR SIGN	CAL DA	20.0	6.0	4.0	5.5	1.0	2.0	1.5

*SPECIALTY ITEMS

• CHAMPAIGN & VERMILION

FILE NAME :	USER NAME : coombessf	DESIGNED -	REVISED -	STATE OF ILLINOIS DEPARTMENT OF TRANSPORTATION	SUMMARY OF QUANTITIES	F.A.I. RTE.:	SECTION:	COUNTY:	TOTAL SHEETS:	SHEET NO.:
ci:\pvt\work\pvidat\coombessf\0329584\0570986-ant-200.dgn	0329584-ant-200.dgn	DRAWN -	REVISED -			57&74	05 PATCHING 2013-5	•	24	7
	PLOT SCALE : 40,0000 ' / 1" =	CHECKED -	REVISED -							
	PLOT DATE : 1/31/2013	DATE -	REVISED -							
						SCALE:	SHEET NO. OF SHEETS	STA. TO STA.	CONTRACT NO. 70986	
						ILLINOIS FED. AID PROJECT				

SUMMARY OF QUANTITIES

LOCATION OF WORK:	FAI 57	FAI 57	FAI 74	FAI 74	FAI 74	FAI 74
	RURAL	URBAN	RURAL	URBAN	RURAL	URBAN
	INTERSTATE	INTERSTATE	INTERSTATE	INTERSTATE	INTERSTATE	INTERSTATE
	CHAMPAIGN COUNTY	CHAMPAIGN COUNTY	CHAMPAIGN COUNTY	CHAMPAIGN COUNTY	VERMILION COUNTY	VERMILION COUNTY
FUNDING BREAKOUT:	100 % STATE	100 % STATE	100 % STATE	100 % STATE	100 % STATE	100 % STATE
CONSTRUCTION TYPE CODE:	0005	0005	0005	0005	0005	0005

CODE NO.	ITEM	UNIT	TOTAL QUANTITY	QUANTITY	QUANTITY	QUANTITY	QUANTITY	QUANTITY	QUANTITY
X7015005	CHANGEABLE MESSAGE SIGN	CAL DA	28.0	9.0	5.0	8.0	1.0	3.0	2.0

*SPECIALTY ITEMS

• CHAMPAIGN & VERMILION

FILE NAME : c:\pwwork\pwwork\coombessf\0032958\0070986-shs-500.dgn	USER NAME : coombessf	DESIGNED -	REVISED -	STATE OF ILLINOIS DEPARTMENT OF TRANSPORTATION	SUMMARY OF QUANTITIES	F.A.I. RTE. 57&74	SECTION D5 PATCHING 2013-5	COUNTY •	TOTAL SHEETS 24	SHEET NO. 8
	PLOT SCALE : 48.0000' = 1" (1)	DRAWN -	REVISED -		SCALE:					
	PLOT DATE : 1/31/2013	CHECKED -	REVISED -		SHEET NO. OF SHEETS	STA. TO STA.				CONTRACT NO. 70986
		DATE -	REVISED -							ILLINOIS FED. AID PROJECT

LOCATION # 1

EXISTING TYPICAL SECTION ①

STATION	TO	STATION
350+00.00		526+64.06 (NB & SB)
83+43.47		401+15.77 (NB) ③
83+43.47		135+00.00 (SB) ②
② 346+13.00		401+15.77 (SB) ③

STATION EQUATIONS:
 STA 526+64.08 (BK) = STA 83+45.47 (AH)
 STA 373+56.20 (BK) = STA 373+51.69 (AH)

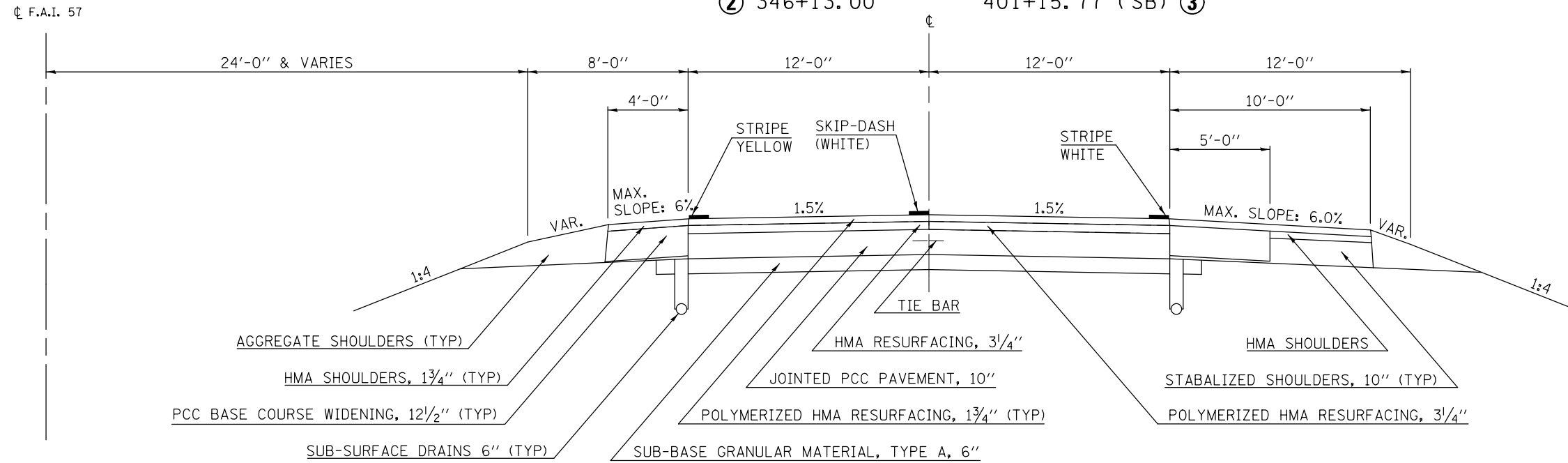

LOCATION # 1

EXISTING TYPICAL SECTION ②

STATION	TO	STATION
① 135+00.00		346+13.00 (SB) ①

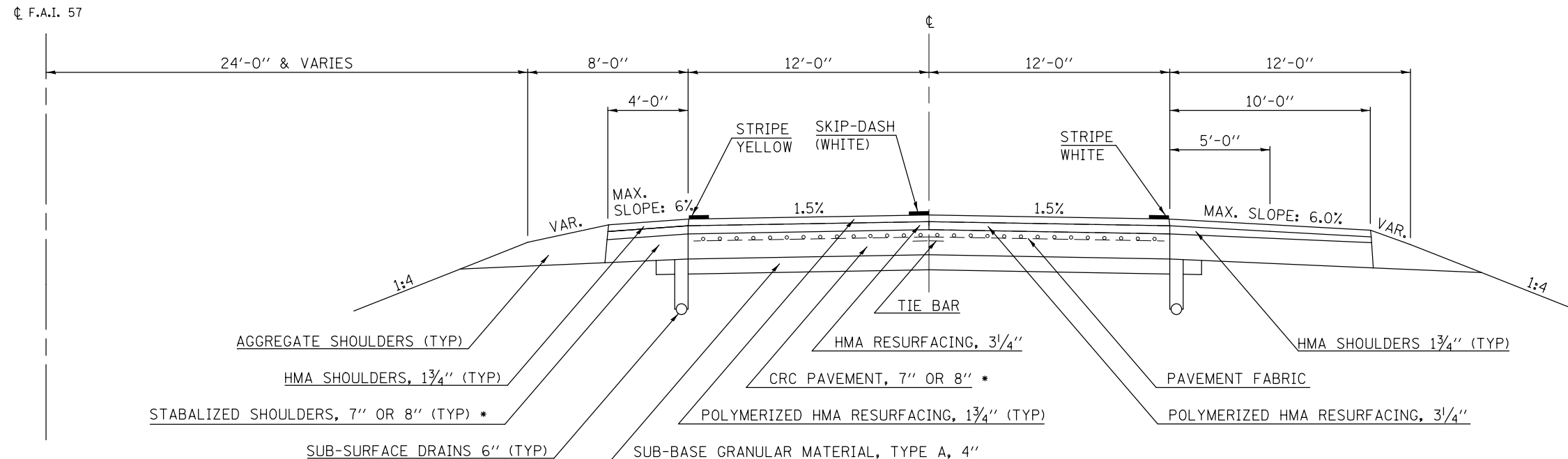

* STA. 135+00.00 TO STA. 241+00.00 - 7"
 STA. 241+00.00 TO STA. 346+13.00 - 8"

• CHAMPAIGN & VERMILION

FILE NAME =	USER NAME = coombessf	DESIGNED -	REVISED -
ci:\pwork\pwork\coombessf\d0329584\0570986-shr-typicals.dgn		DRAWN -	REVISED -
		CHECKED -	REVISED -
		DATE -	REVISED -

**STATE OF ILLINOIS
 DEPARTMENT OF TRANSPORTATION**

TYPICAL CROSS SECTIONS			
SCALE:	SHEET	OF SHEETS	STA. TO STA.

F.A.I. RTE.	SECTION	COUNTY	TOTAL SHEETS	SHEET NO.
57&74	D5 PATCHING 2013-5	*	24	9
CONTRACT NO. 70986				
ILLINOIS FED. AID PROJECT				

EXISTING TYPICAL SECTION ③

LOCATION # 1

STATION	TO	STATION
① 401+15.77		492+69.23 ④
④ 522+00.92		545+00.00 ⑤

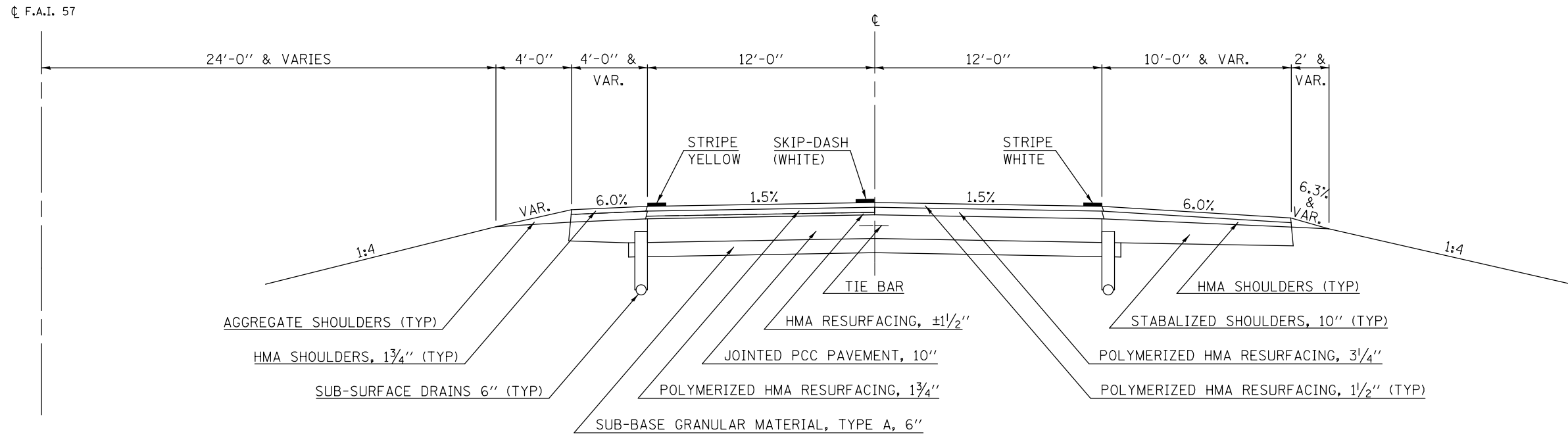

EXISTING TYPICAL SECTION ④

LOCATION # 1

STATION	TO	STATION
③ 492+69.23		522+00.92 ③

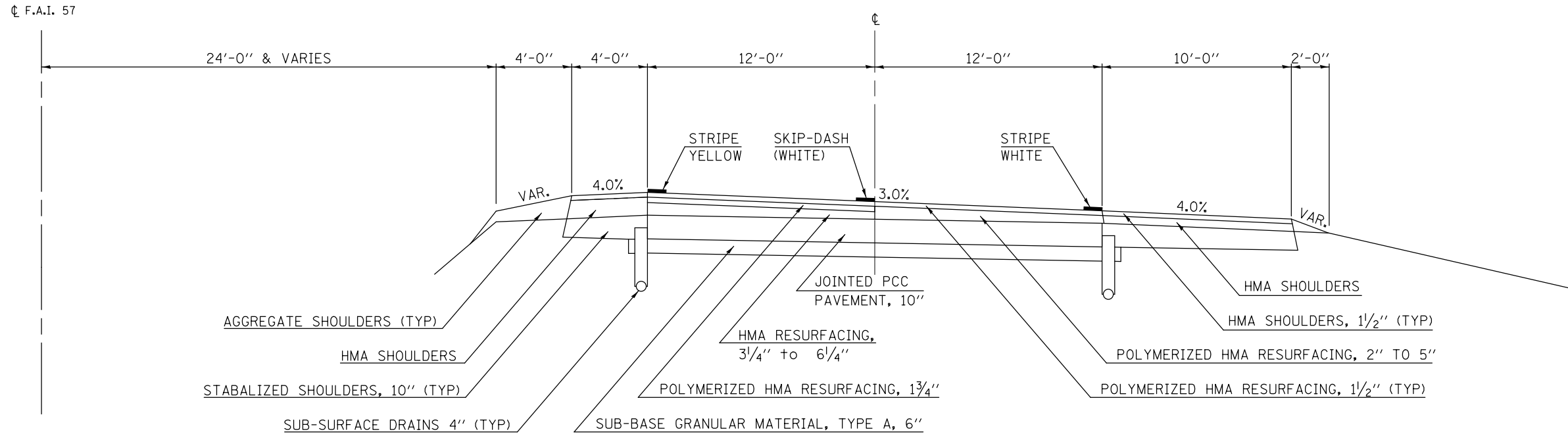

FILE NAME =	USER NAME = coombessf	DESIGNED -	REVISED -
ct:\pwork\pwork\coombessf\0329584\0570986-sh-typical.dgn		DRAWN -	REVISED -
	PLOT SCALE = 40.0000' / in.	CHECKED -	REVISED -
#MODELNAME#	PLOT DATE = 1/31/2013	DATE -	REVISED -

**STATE OF ILLINOIS
DEPARTMENT OF TRANSPORTATION**

TYPICAL CROSS SECTIONS			
SCALE:	SHEET	OF SHEETS	STA. TO STA.

F.A.I. RTE.	SECTION	COUNTY	TOTAL SHEETS	SHEET NO.
57&74	D5 PATCHING 2013-5	*	24	10
			CONTRACT NO. 70986	
ILLINOIS FED. AID PROJECT				

• CHAMPAIGN & VERMILION

EXISTING TYPICAL SECTION ⑤

LOCATION #1

STATION TO STATION
 ③ 545+00.00 575+00.00 ⑥

☉ F.A.I. 57

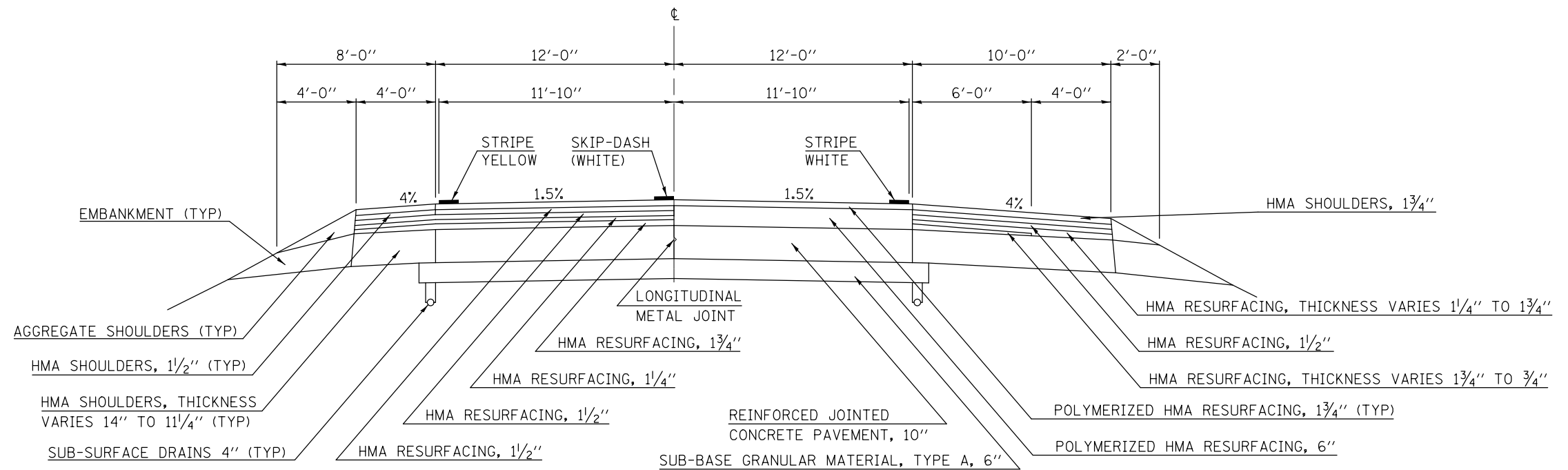

EXISTING TYPICAL SECTION ⑥

LOCATION #1

STATION TO STATION
 ⑤ 575+00.00 623+36.00 ⑦ ⑧

☉ F.A.I. 57

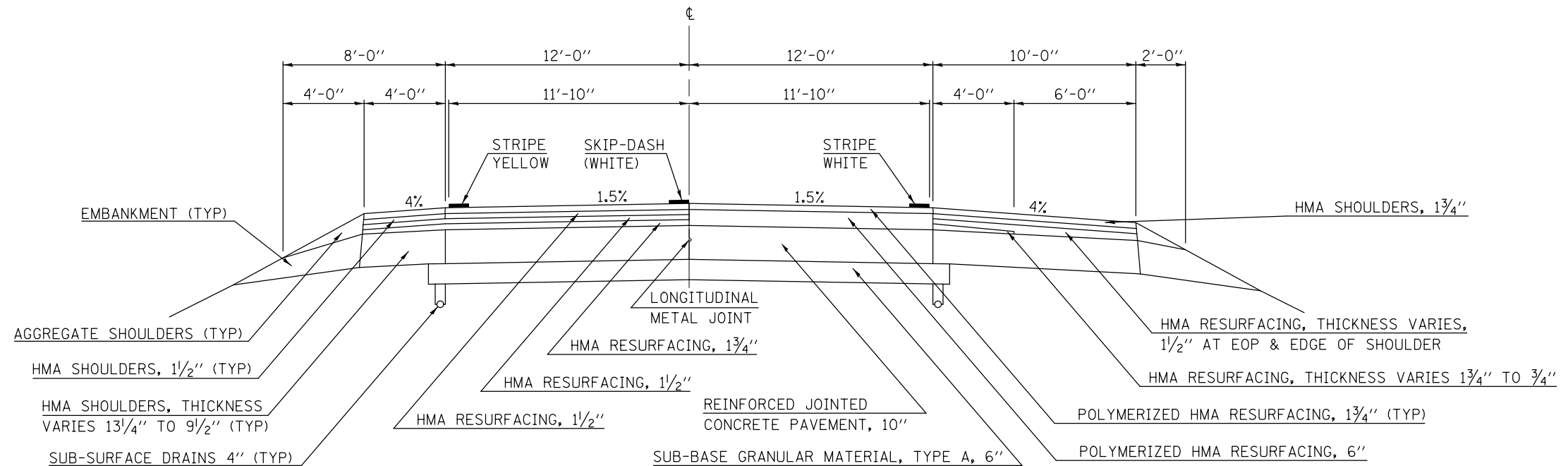

• CHAMPAIGN & VERMILION

FILE NAME =	USER NAME = coombessf	DESIGNED -	REVISED -	STATE OF ILLINOIS DEPARTMENT OF TRANSPORTATION	TYPICAL CROSS SECTIONS	SCALE:	SHEET OF SHEETS	STA. TO STA.	F.A.I. RTE. SECTION COUNTY TOTAL SHEETS SHEET NO.
ct:\pwork\pwork\coombessf\0329584\0570986-shr-typicals.dgn		DRAWN -	REVISED -						57&74 D5 PATCHING 2013-5 • 24 11
	PLOT SCALE = 40.0000' / in.	CHECKED -	REVISED -						CONTRACT NO. 70986
#MODELNAME#	PLOT DATE = 1/31/2013	DATE -	REVISED -						ILLINOIS FED. AID PROJECT

EXISTING TYPICAL SECTION ⑦

NORTHBOUND LANES

LOCATION #1

STATION I/O STATION
 ⑥ 623+36.00 637+33.00 ⑨

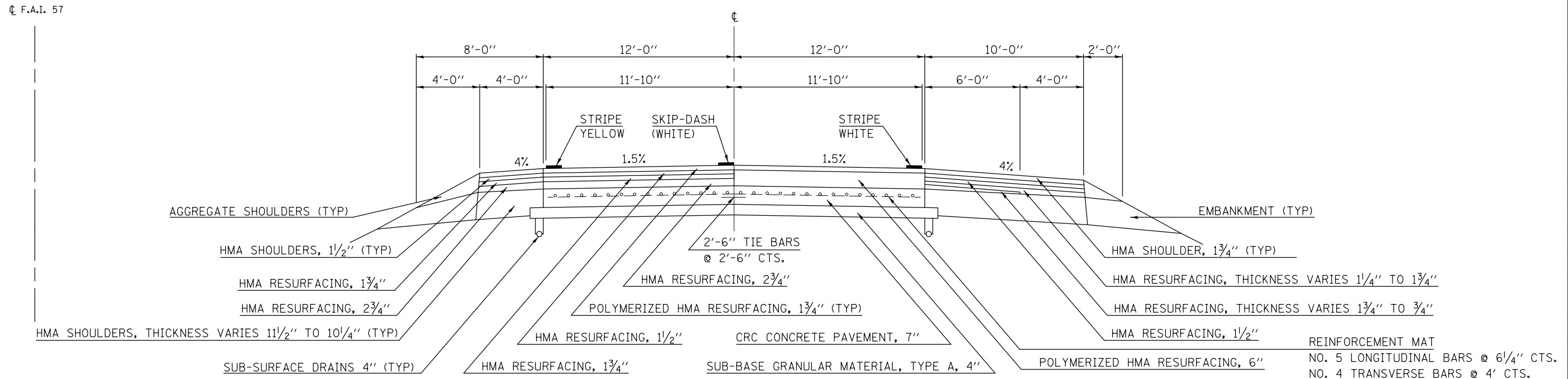

EXISTING TYPICAL SECTION ⑧

SOUTHBOUND LANES

LOCATION #1

STATION I/O STATION
 ⑥ 623+36.00 637+33.00 ⑩

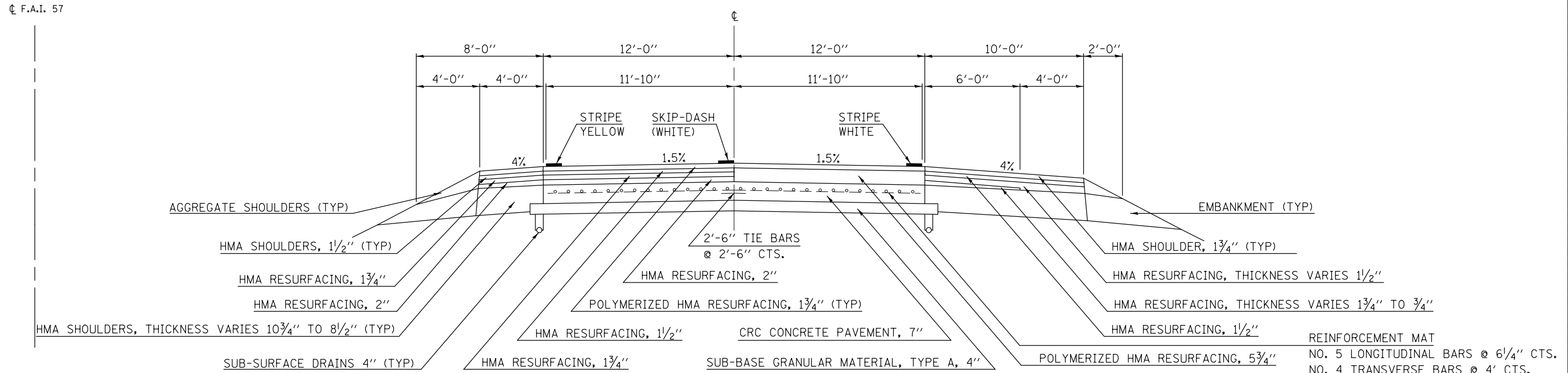

FILE NAME =	USER NAME = coombessf	DESIGNED -	REVISED -
ct:\pwork\pwork\coombessf\0329584\0570986-sh-t-typicals.dgn		DRAWN -	REVISED -
		CHECKED -	REVISED -
		DATE -	REVISED -

STATE OF ILLINOIS
DEPARTMENT OF TRANSPORTATION

TYPICAL CROSS SECTIONS			
SCALE:	SHEET	OF SHEETS	STA. TO STA.

F.A.I. RTE.	SECTION	COUNTY	TOTAL SHEETS	SHEET NO.
57&74	D5 PATCHING 2013-5		24	12
CONTRACT NO. 70986			ILLINOIS FED. AID PROJECT	

EXISTING TYPICAL SECTION ⑨

NORTHBOUND LANES

LOCATION #1

STATION I/O STATION
 ⑦ 637+33.00 904+97.02

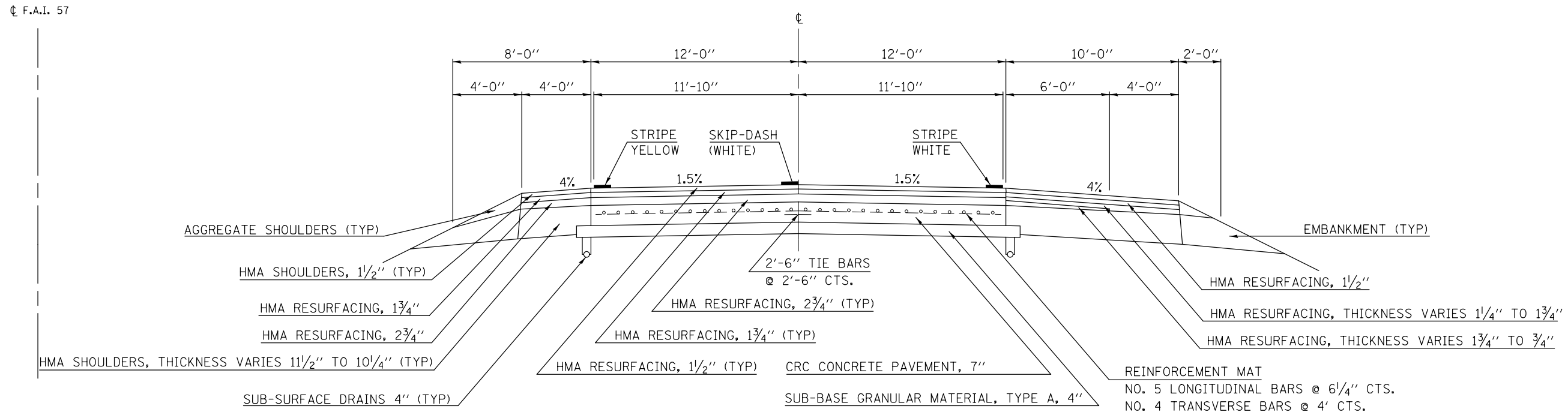

EXISTING TYPICAL SECTION ⑩

SOUTHBOUND LANES

LOCATION #1

STATION I/O STATION
 ⑧ 637+33.00 921+21.03

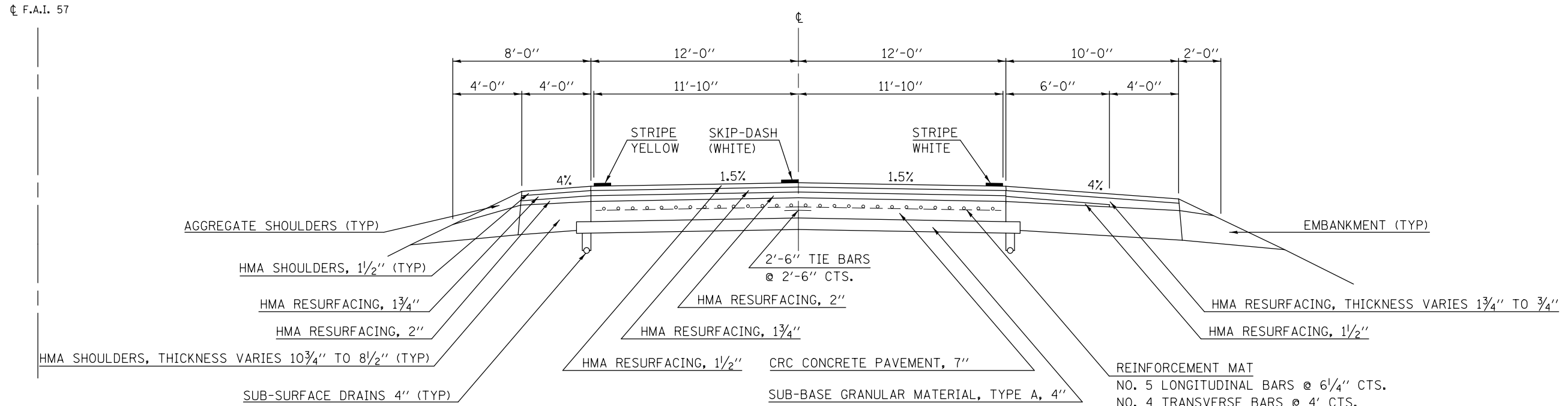

FILE NAME =	USER NAME = coombessf	DESIGNED -	REVISED -	STATE OF ILLINOIS DEPARTMENT OF TRANSPORTATION	TYPICAL CROSS SECTIONS			F.A.I. RTE.	SECTION	COUNTY	TOTAL SHEETS	SHEET NO.
		DRAWN -	REVISED -					57&74	D5 PATCHING 2013-5	*	24	13
		CHECKED -	REVISED -					CONTRACT NO. 70986				
#MODELNAME#	PLOT DATE = 1/31/2013	DATE -	REVISED -		SCALE:	SHEET	OF	SHEETS	STA.	TO	STA.	ILLINOIS FED. AID PROJECT

* CHAMPAIGN & VERMILION

EXISTING TYPICAL SECTION 11

LOCATION #2

STATION IO STATION
1495+21.00 1871+45.21

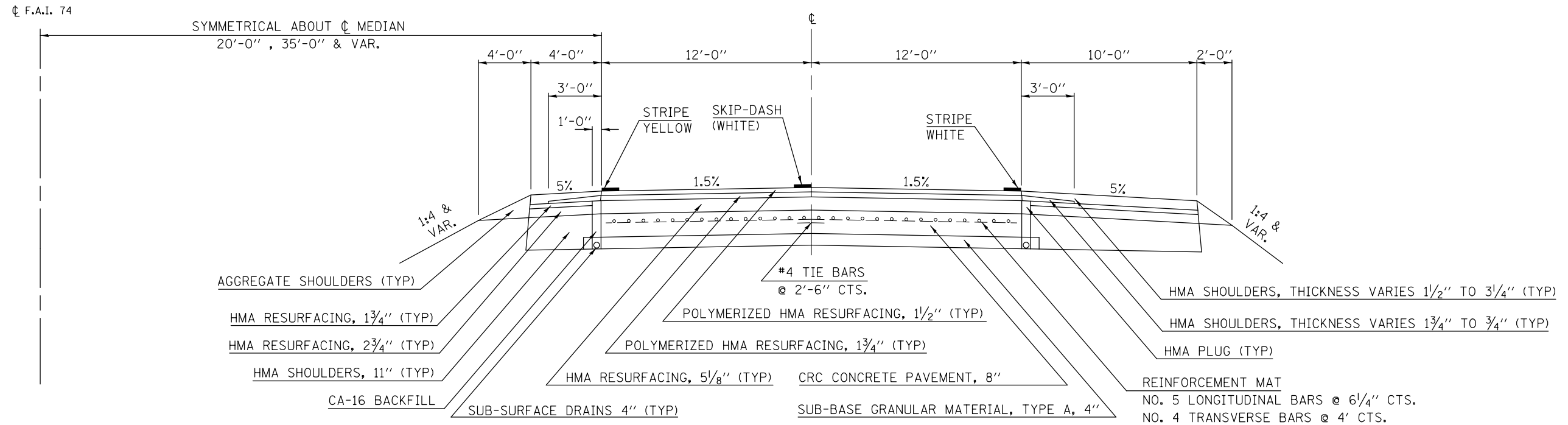

EXISTING TYPICAL SECTION 12

LOCATION #2

STATION IO STATION
429+00.00 880+00.00 13

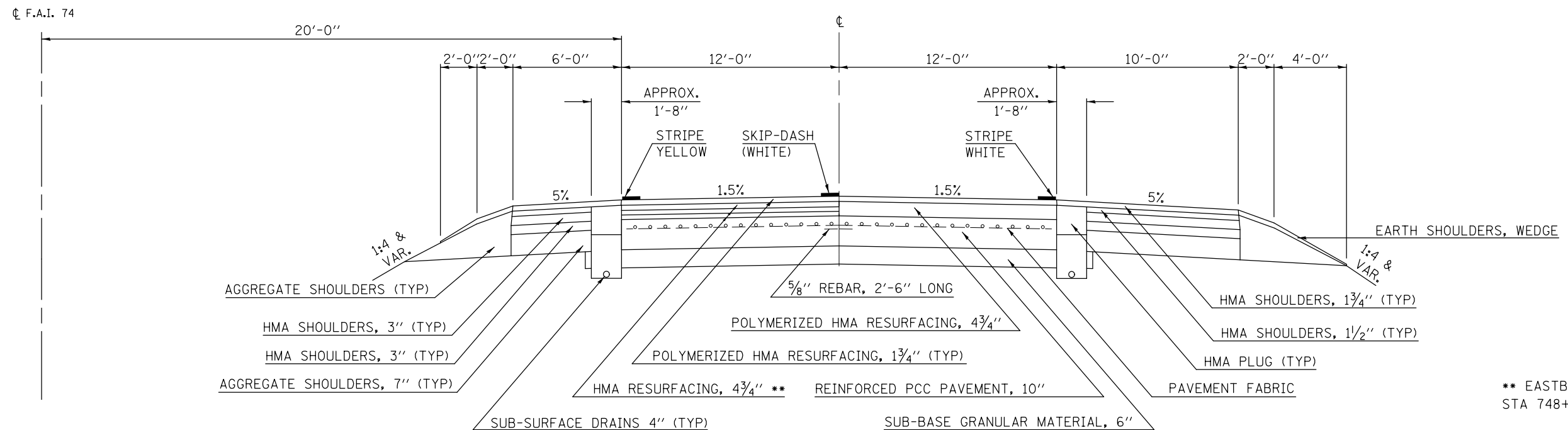

** EASTBOUND LANES - STA 730+0 TO STA 748+00 HMA RESURFACING = 6"±

FILE NAME =	USER NAME = coombessf	DESIGNED -	REVISED -	STATE OF ILLINOIS DEPARTMENT OF TRANSPORTATION	TYPICAL CROSS SECTIONS				F.A.I. RTE.	SECTION	COUNTY	TOTAL SHEETS	SHEET NO.			
ci:\pw\work\p1dot\coombessf\d0329584\0570986-sht-Typicals.dgn		DRAWN -	REVISED -		SCALE:	SHEET	OF	SHEETS	STA.	TO	STA.	57&74	D5 PATCHING 2013-5	*	24	14
		CHECKED -	REVISED -													
#MODELNAME#		DATE -	REVISED -													

* CHAMPAIGN & VERMILION

ILLINOIS FED. AID PROJECT

EXISTING TYPICAL SECTION 13

LOCATION #2 AND #3

STATION 12 880+00.00 TO STATION 14 1616+00.00

CHAMPAIGN AND VERMILION COUNTY
LINE AT STA 1053+06.00

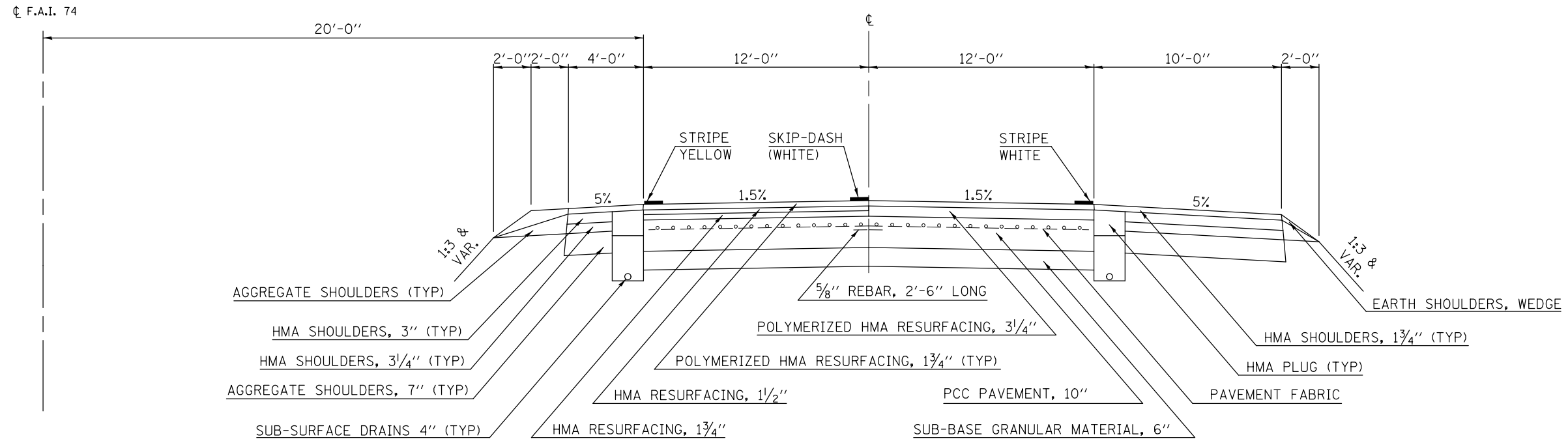

EXISTING TYPICAL SECTION 14

LOCATION #3

STATION 13 1616+00.00 TO STATION 15 1720+00.00

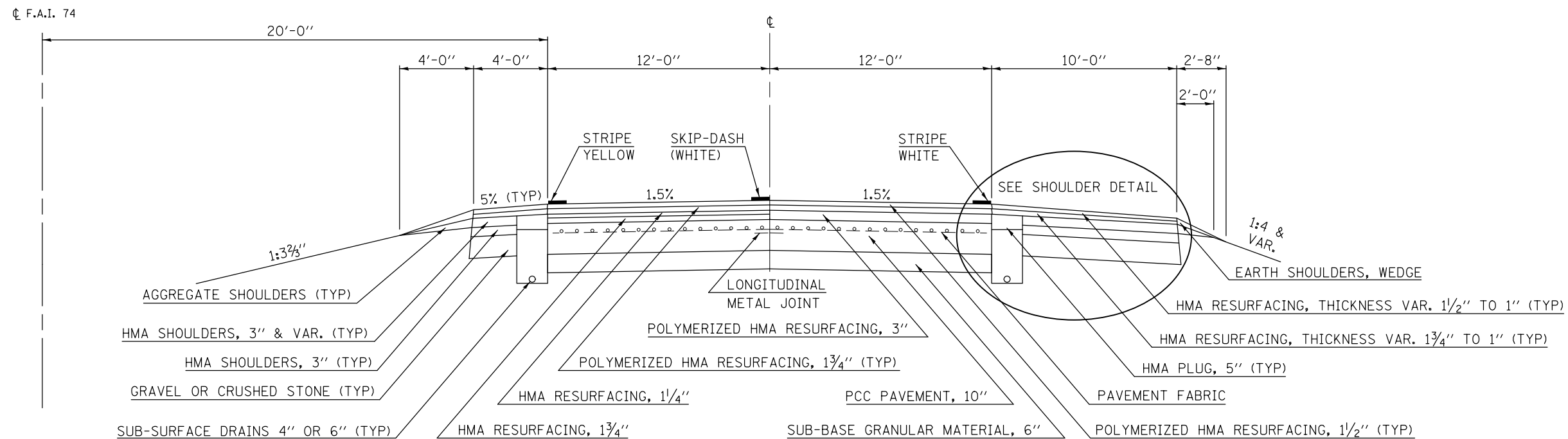

SHOULDER DETAIL

LT. 1618+87.00 TO LT. 1627+88.22
RT. 1624+65.29 TO RT. 1627+88.22

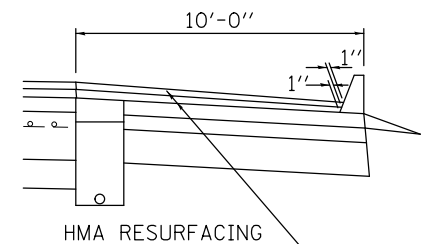

SHOULDER DETAIL

LT. 1631.89.30 TO LT. 1647+92.36 (WB)
RT. 1631+89.63 TO RT. 1647+36.45 (EB)

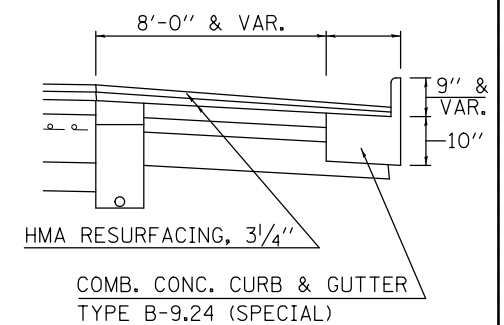

FILE NAME =	USER NAME = coombessf	DESIGNED -	REVISED -
ci:\pw\work\p\dot\coombessf\d0329584\0570986-sh-t-typicals.dgn		DRAWN -	REVISED -
		CHECKED -	REVISED -
		DATE -	REVISED -
#MODELNAME#	PLOT DATE = 1/31/2013		

STATE OF ILLINOIS
DEPARTMENT OF TRANSPORTATION

TYPICAL CROSS SECTIONS

SCALE: SHEET OF SHEETS STA. TO STA.

F.A.I. RTE.	SECTION	COUNTY	TOTAL SHEETS	SHEET NO.
57&74	D5 PATCHING 2013-5		24	15
CONTRACT NO. 70986			ILLINOIS FED. AID PROJECT	

• CHAMPAIGN & VERMILION

SCHEDULE OF QUANTITIES

I-57 CLASS A 13" PATCHING										
STATION	LOCATION	LANE	LENGTH (FT)	WIDTH (FT)	PATCH AREA			SAW CUTS (FT)	TIE BARS 3/4" (EACH)	PATCHING REINFORCEMENT (SQ YD)
					TYPE I 13.0' ' 44200608 (SQ YD)	TYPE II 13.0' ' 44200610 (SQ YD)	TYPE IV 13.0' ' 44200614 (SQ YD)			
647+28.49	I-57 NB (URBAN)	DL	6	12	0.0	8.0	0.0	60.0	0	8.0
649+50.25	I-57 NB (URBAN)	DL	6	6	4.0	0.0	0.0	36.0	0	4.0
649+71.37	I-57 NB (URBAN)	DL	10	6	0.0	6.7	0.0	44.0	0	6.7
651+72.01	I-57 NB (URBAN)	DL	6	6	4.0	0.0	0.0	36.0	0	4.0
652+30.09	I-57 NB (URBAN)	DL	6	6	4.0	0.0	0.0	36.0	0	4.0
654+57.13	I-57 NB (URBAN)	DL	20	6	0.0	13.3	0.0	64.0	10	13.3
658+53.13	I-57 NB (URBAN)	DL	8	6	0.0	5.3	0.0	40.0	0	5.3
673+31.53	I-57 NB (URBAN)	DL	6	6	4.0	0.0	0.0	36.0	0	4.0
680+54.89	I-57 NB (URBAN)	DL	6	6	4.0	0.0	0.0	36.0	0	4.0
685+40.65	I-57 NB (RURAL)	DL	6	6	4.0	0.0	0.0	36.0	0	4.0
690+00.01	I-57 NB (RURAL)	DL	8	6	0.0	5.3	0.0	40.0	0	5.3
713+70.73	I-57 NB (RURAL)	DL	6	12	0.0	8.0	0.0	60.0	0	8.0
714+12.97	I-57 NB (RURAL)	DL	6	12	0.0	8.0	0.0	60.0	0	8.0
714+12.97	I-57 NB (RURAL)	PL	6	12	0.0	8.0	0.0	60.0	0	8.0
720+99.37	I-57 NB (RURAL)	DL	6	6	4.0	0.0	0.0	36.0	0	4.0
733+70.85	I-57 NB (RURAL)	DL	10	6	0.0	6.7	0.0	44.0	0	6.7
733+98.25	I-57 NB (RURAL)	DL	10	6	0.0	6.7	0.0	44.0	0	6.7
743+59.21	I-57 NB (RURAL)	DL	40	6	0.0	0.0	26.7	104.0	20	26.7
764+39.53	I-57 NB (RURAL)	DL	20	6	0.0	13.3	0.0	64.0	10	13.3
777+24.96	I-57 NB (RURAL)	DL	50	6	0.0	0.0	33.3	124.0	25	33.3
789+97.44	I-57 NB (RURAL)	DL	40	6	0.0	0.0	26.7	104.0	20	26.7
I-57 CLASS A, 13" SUB TOTALS					28.0 (SQ YD)	89.3 (SQ YD)	86.7 (SQ YD)	1164.0 (FT)	85.0 (EACH)	204.0 (SQ YD)

*CHAMPAIGN & VERMILION

SCHEDULE OF QUANTITIES

I-57 CLASS A 13" PATCHING CONT.										
STATION	LOCATION	LANE	LENGTH (FT)	WIDTH (FT)	PATCH AREA			SAW CUTS (FT)	TIE BARS 3/4" (EACH)	PATCHING REINFORCEMENT (SQ YD)
					TYPE I 13.0' ' 44200608 (SQ YD)	TYPE II 13.0' ' 44200610 (SQ YD)	TYPE IV 13.0' ' 44200614 (SQ YD)			
792+61.44	I-57 NB (RURAL)	DL	40	6	0.0	0.0	26.7	104.0	20	26.7
793+77.60	I-57 NB (RURAL)	DL	40	6	0.0	0.0	26.7	104.0	20	26.7
796+68.00	I-57 NB (RURAL)	DL	80	6	0.0	0.0	53.3	184.0	40	53.3
800+90.40	I-57 NB (RURAL)	DL	6	6	4.0	0.0	0.0	36.0	0	4.0
806+39.52	I-57 NB (RURAL)	DL	6	6	4.0	0.0	0.0	36.0	0	4.0
811+93.92	I-57 NB (RURAL)	DL	10	6	0.0	6.7	0.0	44.0	0	6.7
814+42.08	I-57 NB (RURAL)	DL	15	6	0.0	10.0	0.0	54.0	0	10.0
817+80.00	I-57 NB (RURAL)	DL	40	6	0.0	0.0	26.7	104.0	20	26.7
819+59.52	I-57 NB (RURAL)	DL	12	6	0.0	8.0	0.0	48.0	0	8.0
I-57 CLASS A, 13" SUB TOTALS					8.0 (SQ YD)	24.7 (SQ YD)	133.3 (SQ YD)	714.0 (FT)	100.0 (EACH)	166.0 (SQ YD)

	PATCH AREA			SAW CUTS (FT)	TIE BARS 3/4" (EACH)	PATCHING REINFORCEMENT (SQ YD)
	TYPE I 13.0' ' 44200608 (SQ YD)	TYPE II 13.0' ' 44200610 (SQ YD)	TYPE IV 13.0' ' 44200614 (SQ YD)			
I-57 CLASS A, 13" PATCHING TOTALS	36.0 (SQ YD)	114.0 (SQ YD)	220.0 (SQ YD)	1878.0 (FT)	185.0 (EACH)	370.0 (SQ YD)

*CHAMPAIGN & VERMILION

SCHEDULE OF QUANTITIES

I-57 CLASS B 15" PATCHING											
STATION	LOCATION	LANE	LENGTH (FT)	WIDTH (FT)	PATCH AREA			DOWEL BARS 44201299 (EACH)	SAW CUTS 44213200 (FT)	TIE BARS 1 1/4" 44213208 (EACH)	PAVEMENT FABRIC 44213100 (SQ YD)
					TYPE II 15.0' ' 44201031 (SQ YD)	TYPE III 15.0' ' 44201035 (SQ YD)	TYPE IV 15.0' ' 44201037 (SQ YD)				
					367+65.60	I-57 NB (RURAL)	DL				
424+20.48	I-57 NB (RURAL)	DL	20	12	0.0	0.0	26.7	30	76.0	10	26.7
436+56.00	I-57 NB (RURAL)	DL	10	12	13.3	0.0	0.0	20	56.0	0	0.0
436+56.00	I-57 NB (RURAL)	PL	10	12	13.3	0.0	0.0	20	56.0	0	0.0
436+82.40	I-57 NB (RURAL)	DL	30	12	0.0	0.0	40.0	30	96.0	15	40.0
436+82.40	I-57 NB (RURAL)	PL	30	12	0.0	0.0	40.0	30	96.0	15	40.0
503+45.76	I-57 NB (RURAL)	DL	6	12	8.0	0.0	0.0	20	48.0	0	0.0
332+98.75	I-57 NB (URBAN)	DL	6	12	8.0	0.0	0.0	20	48.0	0	0.0
332+98.75	I-57 NB (URBAN)	PL	6	12	8.0	0.0	0.0	20	48.0	0	0.0
350+93.95	I-57 NB (URBAN)	DL	6	12	8.0	0.0	0.0	20	48.0	0	0.0
350+93.95	I-57 NB (URBAN)	PL	6	12	8.0	0.0	0.0	20	48.0	0	0.0
354+89.95	I-57 NB (URBAN)	DL	6	12	8.0	0.0	0.0	20	48.0	0	0.0
420+98.41	I-57 NB (URBAN)	DL	6	12	8.0	0.0	0.0	20	48.0	0	0.0
420+98.41	I-57 NB (URBAN)	PL	6	12	8.0	0.0	0.0	20	48.0	0	0.0
525+47.53	I-57 NB (URBAN)	DL	6	12	8.0	0.0	0.0	20	48.0	0	0.0
525+47.53	I-57 NB (URBAN)	PL	6	12	8.0	0.0	0.0	20	48.0	0	0.0
I-57 CLASS B, 15" SUB TOTALS					106.7 (SQ YD)	20.0 (SQ YD)	106.7 (SQ YD)	350.0 (EACH)	926.0 (FT)	40.0 (EACH)	126.7 (SQ YD)

*CHAMPAIGN & VERMILION

SCHEDULE OF QUANTITIES

I-57 CLASS B 15" PATCHING CONT.											
STATION	LOCATION	LANE	LENGTH (FT)	WIDTH (FT)	PATCH AREA			DOWEL BARS 44201299 (EACH)	SAW CUTS 44213200 (FT)	TIE BARS 1 1/4" 44213208 (EACH)	PAVEMENT FABRIC 42001200 (SQ YD)
					TYPE II 15.0' ' 44201031 (SQ YD)	TYPE III 15.0' ' 44201035 (SQ YD)	TYPE IV 15.0' ' 44201037 (SQ YD)				
350+02.08	I-57 SB (RURAL)	DL	12	12	0.0	16.0	0.0	20	60.0	0	16.0
365+96.64	I-57 SB (RURAL)	DL	6	12	8.0	0.0	0.0	20	48.0	0	0.0
436+50.72	I-57 SB (RURAL)	DL	10	12	13.3	0.0	0.0	20	56.0	0	0.0
436+50.72	I-57 SB (RURAL)	PL	10	12	13.3	0.0	0.0	20	56.0	0	0.0
436+82.40	I-57 SB (RURAL)	DL	10	12	13.3	0.0	0.0	20	56.0	0	0.0
436+82.40	I-57 SB (RURAL)	PL	10	12	13.3	0.0	0.0	20	56.0	0	0.0
403+98.25	I-57 SB (URBAN)	DL	30	12	0.0	0.0	40.0	30	96.0	15	40.0
414+06.73	I-57 SB (URBAN)	DL	6	12	8.0	0.0	0.0	20	48.0	0	0.0
414+06.73	I-57 SB (URBAN)	PL	6	12	8.0	0.0	0.0	20	48.0	0	0.0
418+08.01	I-57 SB (URBAN)	DL	6	12	8.0	0.0	0.0	20	48.0	0	0.0
418+08.01	I-57 SB (URBAN)	PL	6	12	8.0	0.0	0.0	20	48.0	0	0.0
427+90.09	I-57 SB (URBAN)	DL	6	12	8.0	0.0	0.0	20	48.0	0	0.0
427+90.09	I-57 SB (URBAN)	PL	6	12	8.0	0.0	0.0	20	48.0	0	0.0
441+78.73	I-57 SB (URBAN)	DL	6	12	8.0	0.0	0.0	20	48.0	0	0.0
441+78.73	I-57 SB (URBAN)	PL	6	12	8.0	0.0	0.0	20	48.0	0	0.0
448+75.69	I-57 SB (URBAN)	DL	6	12	8.0	0.0	0.0	20	48.0	0	0.0
448+75.69	I-57 SB (URBAN)	PL	6	12	8.0	0.0	0.0	20	48.0	0	0.0
I-57 CLASS B, 15" SUB TOTALS					141.3 (SQ YD)	16.0 (SQ YD)	40.0 (SQ YD)	350.0 (EACH)	908.0 (FT)	15.0 (EACH)	56.0 (SQ YD)

	PATCH AREA			DOWEL BARS 44201299 (EACH)	SAW CUTS 44213200 (FT)	TIE BARS 1 1/4" 44213208 (EACH)	PAVEMENT FABRIC 42001200 (SQ YD)
	TYPE II 15.0' ' 44201031 (SQ YD)	TYPE III 15.0' ' 44201035 (SQ YD)	TYPE IV 15.0' ' 44201037 (SQ YD)				
I-57 CLASS B, 15" PATCHING TOTALS	248.0 (SQ YD)	36.0 (SQ YD)	146.7 (SQ YD)	700.0 (EACH)	1834.0 (FT)	55.0 (EACH)	182.7 (SQ YD)

SCHEDULE OF QUANTITIES

I-57 CLASS B 16" PATCHING											
STATION	LOCATION	LANE	LENGTH (FT)	WIDTH (FT)	PATCH AREA			DOWEL BARS 44201299 (EACH)	SAW CUTS 44213200 (FT)	TIE BARS 1 1/4" 44213208 (EACH)	PAVEMENT FABRIC 44213100 (SQ YD)
					TYPE I 16.0' ' 44201039 (SQ YD)	TYPE II 16.0' ' 44201043 (SQ YD)	TYPE IV 16.0' ' 44201048 (SQ YD)				
367+97.28	I-57 SB (RURAL)	DL	10	12	0.0	13.3	0.0	20	56.0	0	0.0
367+97.28	I-57 SB (RURAL)	PL	8	12	0.0	10.7	0.0	20	52.0	0	0.0
508+57.93	I-57 NB (URBAN)	DL	6	6	4.0	0.0	0.0	8	30.0	0	0.0
514+44.01	I-57 NB (URBAN)	DL	30	12	0.0	0.0	40.0	30	96.0	15	40.0
I-57 CLASS B, 16" PATCHING TOTALS					4.0 (SQ YD)	24.0 (SQ YD)	40.0 (SQ YD)	78.0 (EACH)	234.0 (FT)	15.0 (EACH)	40.0 (SQ YD)

I-57 CLASS B 17" PATCHING											
STATION	LOCATION	LANE	LENGTH (FT)	WIDTH (FT)	PATCH AREA			DOWEL BARS 44201299 (EACH)	SAW CUTS 44213200 (FT)	TIE BARS 1 1/4" 44213208 (EACH)	PAVEMENT FABRIC 44213100 (SQ YD)
					TYPE I 17.0' ' 44201054 (SQ YD)	TYPE II 17.0' ' 44201055 (SQ YD)	TYPE IV 17.0' ' 44201053 (SQ YD)				
499+76.17	I-57 SB (URBAN)	DL	6	12	0.0	8.0	0.0	20	48.0	0	0.0
517+02.73	I-57 SB (URBAN)	DL	6	12	0.0	8.0	0.0	20	48.0	0	0.0
508+57.93	I-57 NB (URBAN)	DL	6	6	4.0	0.0	0.0	8	30.0	0	0.0
514+44.01	I-57 NB (URBAN)	DL	30	12	0.0	0.0	40.0	30	96.0	15	40.0
I-57 CLASS B, 17" PATCHING TOTALS					4.0 (SQ YD)	16.0 (SQ YD)	40.0 (SQ YD)	78.0 (EACH)	222.0 (FT)	15.0 (EACH)	40.0 (SQ YD)

I-57 CLASS B 18" PATCHING							
STATION	LOCATION	LANE	LENGTH (FT)	WIDTH (FT)	PATCH AREA	DOWEL BARS 44201299 (EACH)	SAW CUTS 44213200 (FT)
					TYPE II 18.0' ' 44201063 (SQ YD)		
499+76.17	I-57 SB (URBAN)	PL	6	12	8.0	20	48.0
517+02.73	I-57 SB (URBAN)	PL	6	12	8.0	20	48.0
I-57 CLASS B, 18" PATCHING TOTALS					16.0 (SQ YD)	40.0 (EACH)	96.0 (FT)

*CHAMPAIGN & VERMILION

SCHEDULE OF QUANTITIES

I-74 CLASS A 17" PATCHING										
STATION	DIRECTION	LANE	LENGTH (FT)	WIDTH (FT)	PATCH AREA			SAW CUTS (FT)	TIE BARS 3/4" (EACH)	PATCHING REINFORCEMENT (SQ YD)
					TYPE II 17.0' ' 44200637 (SQ YD)	TYPE III 17.0' ' 44200641 (SQ YD)	TYPE IV 17.0' ' 44200643 (SQ YD)			
1519+43.86	I-74 WB (RURAL)	DL	6	12	8.0	0.0	0.0	60.0	0	8.0
1519+43.86	I-74 WB (RURAL)	PL	6	12	8.0	0.0	0.0	60.0	0	8.0
1519+86.10	I-74 WB (RURAL)	DL	6	12	8.0	0.0	0.0	60.0	0	8.0
1562+15.38	I-74 WB (RURAL)	DL	6	12	8.0	0.0	0.0	60.0	0	8.0
1569+07.06	I-74 WB (RURAL)	DL	8	12	10.7	0.0	0.0	64.0	0	10.7
1569+07.06	I-74 WB (RURAL)	PL	8	12	10.7	0.0	0.0	64.0	0	10.7
1588+18.42	I-74 WB (RURAL)	DL	6	12	8.0	0.0	0.0	60.0	0	8.0
1593+25.30	I-74 WB (RURAL)	DL	8	12	10.7	0.0	0.0	64.0	0	10.7
1593+25.30	I-74 WB (RURAL)	PL	8	12	10.7	0.0	0.0	64.0	0	10.7
1616+85.46	I-74 WB (RURAL)	DL	6	12	8.0	0.0	0.0	60.0	0	8.0
1626+25.30	I-74 WB (RURAL)	DL	6	12	8.0	0.0	0.0	60.0	0	8.0
1652+38.90	I-74 WB (RURAL)	DL	6	12	8.0	0.0	0.0	60.0	0	8.0
1819+18.42	I-74 WB (URBAN)	DL	6	12	8.0	0.0	0.0	60.0	0	8.0
1517+53.78	I-74 EB (RURAL)	PL	6	12	8.0	0.0	0.0	60.0	0	8.0
1519+43.86	I-74 EB (RURAL)	DL	30	12	0.0	0.0	40.0	108.0	15	40.0
1546+15.54	I-74 EB (RURAL)	DL	30	6	0.0	20.0	0.0	84.0	15	20.0
1546+63.06	I-74 EB (RURAL)	DL	40	6	0.0	0.0	26.7	104.0	20	26.7
1546+63.06	I-74 EB (RURAL)	PL	20	12	0.0	0.0	26.7	88.0	10	26.7
1548+26.74	I-74 EB (RURAL)	DL	15	6	10.0	0.0	0.0	54.0	0	10.0
1548+47.86	I-74 EB (RURAL)	DL	20	6	13.3	0.0	0.0	64.0	10	13.3
1570+91.86	I-74 EB (RURAL)	PL	12	12	0.0	16.0	0.0	72.0	0	16.0
1597+26.58	I-74 EB (RURAL)	DL	6	12	8.0	0.0	0.0	60.0	0	8.0
1597+26.58	I-74 EB (RURAL)	PL	12	12	0.0	16.0	0.0	72.0	0	16.0
1644+89.14	I-74 EB (RURAL)	DL	6	12	8.0	0.0	0.0	60.0	0	8.0
1729+84.66	I-74 EB (RURAL)	DL	6	12	8.0	0.0	0.0	60.0	0	8.0
1739+82.58	I-74 EB (RURAL)	DL	30	12	0.0	0.0	40.0	108.0	15	40.0
1739+93.14	I-74 EB (RURAL)	PL	6	12	8.0	0.0	0.0	60.0	0	8.0
I-74 CLASS A, 17" PATCHING TOTALS					178.0 (SQ YD)	52.0 (SQ YD)	133.3 (SQ YD)	1850.0 (FT)	85.0 (EACH)	363.3 (SQ YD)

*CHAMPAIGN & VERMILION

SCHEDULE OF QUANTITIES

I-74 CLASS B 15" PATCHING											
STATION	DIRECTION	LANE	LENGTH (FT)	WIDTH (FT)	PATCH AREA			DOWEL BARS 44201299 (EACH)	SAW CUTS 44213200 (FT)	TIE BARS 1 1/4" 44213208 (EACH)	PAVEMENT FABRIC 44213100 (SQ YD)
					TYPE II 15.0' ' 44201031 (SQ YD)	TYPE III 15.0' ' 44201035 (SQ YD)	TYPE IV 15.0' ' 44201037 (SQ YD)				
880+03.84	I-74 EB (RURAL)	DL	6	12	8.0	0.0	0.0	20	48.0	0	0.0
880+03.84	I-74 EB (RURAL)	PL	6	12	8.0	0.0	0.0	20	48.0	0	0.0
913+09.12	I-74 EB (RURAL)	PL	6	12	8.0	0.0	0.0	20	48.0	0	0.0
934+00.00	I-74 EB (RURAL)	DL	12	12	0.0	16.0	0.0	20	60.0	0	16.0
967+15.84	I-74 EB (RURAL)	PL	6	12	8.0	0.0	0.0	20	48.0	0	0.0
1030+94.08	I-74 EB (RURAL)	DL	10	12	13.3	0.0	0.0	20	56.0	0	0.0
1106+28.64	I-74 EB (RURAL)	DL	6	12	8.0	0.0	0.0	20	48.0	0	0.0
1224+13.60	I-74 EB (RURAL)	DL	8	12	10.7	0.0	0.0	20	52.0	0	0.0
1342+19.68	I-74 EB (RURAL)	DL	6	12	8.0	0.0	0.0	20	48.0	0	0.0
1107+97.60	I-74 WB (RURAL)	DL	6	12	8.0	0.0	0.0	20	48.0	0	0.0
1122+97.12	I-74 WB (RURAL)	DL	8	12	10.7	0.0	0.0	20	52.0	0	0.0
1239+92.32	I-74 WB (RURAL)	PL	10	12	13.3	0.0	0.0	20	56.0	0	0.0
1242+66.88	I-74 WB (RURAL)	DL	6	12	8.0	0.0	0.0	20	48.0	0	0.0
1412+26.24	I-74 WB (RURAL)	DL	6	12	8.0	0.0	0.0	20	48.0	0	0.0
1413+47.68	I-74 WB (RURAL)	DL	25	12	0.0	0.0	33.3	30	86.0	13	0.0
1413+47.68	I-74 WB (RURAL)	PL	25	12	0.0	0.0	33.3	30	86.0	13	0.0
1414+90.24	I-74 WB (RURAL)	DL	6	12	8.0	0.0	0.0	20	48.0	0	0.0
1415+37.76	I-74 WB (RURAL)	DL	6	12	8.0	0.0	0.0	20	48.0	0	0.0
1415+53.60	I-74 WB (RURAL)	DL	6	12	8.0	0.0	0.0	20	48.0	0	0.0
1688+77.60	I-74 WB (URBAN)	DL	30	6	0.0	20.0	0.0	12	78.0	15	20.0
1691+83.84	I-74 WB (URBAN)	DL	6	12	8.0	0.0	0.0	20	48.0	0	0.0
1691+83.84	I-74 WB (URBAN)	PL	6	12	8.0	0.0	0.0	20	48.0	0	0.0
I 74 CLASS B, 15" PATCHING TOTALS					160.0 (SQ YD)	36.0 (SQ YD)	66.7 (SQ YD)	452.0 (EACH)	1198.0 (FT)	41.0 (EACH)	36.0 (SQ YD)

SCHEDULE OF QUANTITIES

I-74 CLASS B 17" PATCHING										
STATION	DIRECTION	LANE	LENGTH	WIDTH	PATCH AREA		DOWEL BARS	SAW CUTS	TIE BARS 1 1/4"	PAVEMENT FABRIC
					TYPE II 17.0'	TYPE IV 17.0'				
			(FT)	(FT)	44201055 (SQ YD)	44201053 (SQ YD)	44201299 (EACH)	44213200 (FT)	44213208 (EACH)	44213100 (SQ YD)
688+21.60	I-74 WB (RURAL)	DL	12	6	8.0	0.0	8	42.0	0	0.0
691+59.52	I-74 WB (RURAL)	DL	8	12	10.7	0.0	20	52.0	0	0.0
740+38.24	I-74 WB (RURAL)	DL	20	12	0.0	26.7	30	76.0	10	26.7
760+81.60	I-74 WB (RURAL)	DL	6	12	8.0	0.0	20	48.0	0	0.0
1899+39.52	I-74 WB (URBAN)	DL	6	12	8.0	0.0	20	48.0	0	0.0
1899+39.52	I-74 WB (URBAN)	PL	6	12	8.0	0.0	20	48.0	0	0.0
1884+24.16	I-74 EB (URBAN)	DL	25	12	0.0	33.3	30	86.0	13	33.3
1886+08.96	I-74 EB (URBAN)	DL	50	12	0.0	66.7	50	136.0	25	66.7
I 74 CLASS B, 17" SUB TOTALS					42.7 (SQ YD)	126.7 (SQ YD)	198.0 (EACH)	536.0 (FT)	48.0 (EACH)	126.7 (SQ YD)

I-74 CLASS B 14" PATCHING							
STATION	DIRECTION	LANE	LENGTH	WIDTH	PATCH AREA	DOWEL BARS	SAW CUTS
					TYPE II 14.0'		
			(FT)	(FT)	44201019 (SQ YD)	44201299 (EACH)	44213200 (FT)
1937+30.56	I-74 WB (URBAN)	PL	6	12	8.0	20	48.0
I 74 CLASS B, 14" PATCHING TOTALS					8.0 (SQ YD)	20.0 (EACH)	48.0 (FT)