

STATE OF ILLINOIS
DEPARTMENT OF TRANSPORTATION

F.A.P. RTE.	SECTION	COUNTY	TOTAL SHEETS	SHEET NO.
823	(24BR-1)BR	WAYNE	57	1
		ILLINOIS	CONTRACT NO. 74857	

FOR INDEX OF SHEETS, SEE SHEET NO. 2

ADT (2019) = 3850
% TRUCKS = 9.6%

PROPOSED HIGHWAY PLANS

FAP ROUTE 823 (ILL 15)
SECTION (24BR-1)BR
PROJECT NHPP-1MFK(031)
BRIDGE SUPERSTRUCTURE
WAYNE COUNTY

C-97-083-18

D-97-044-18

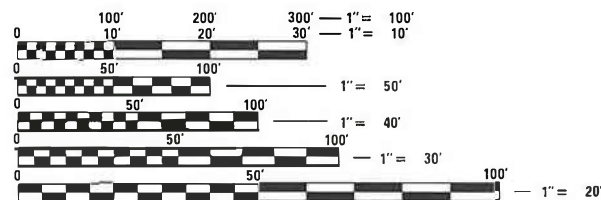
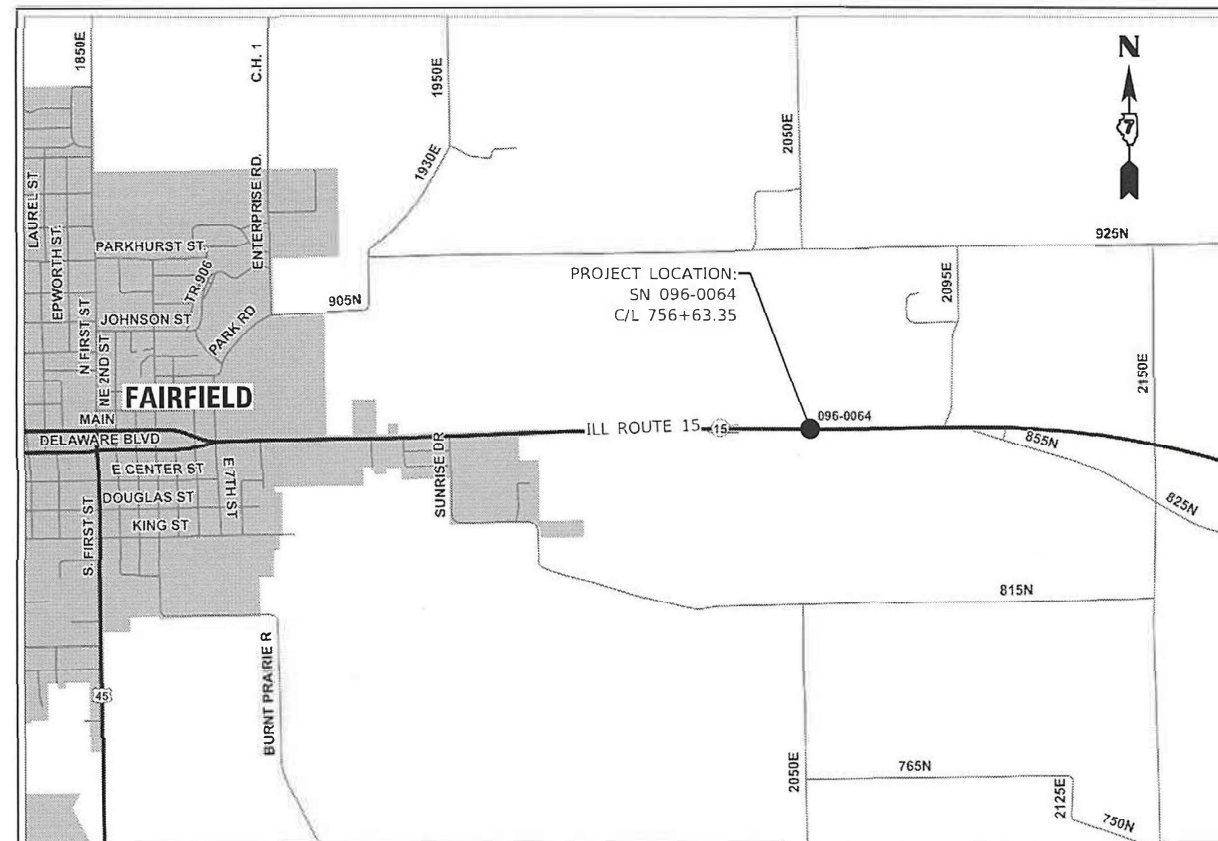
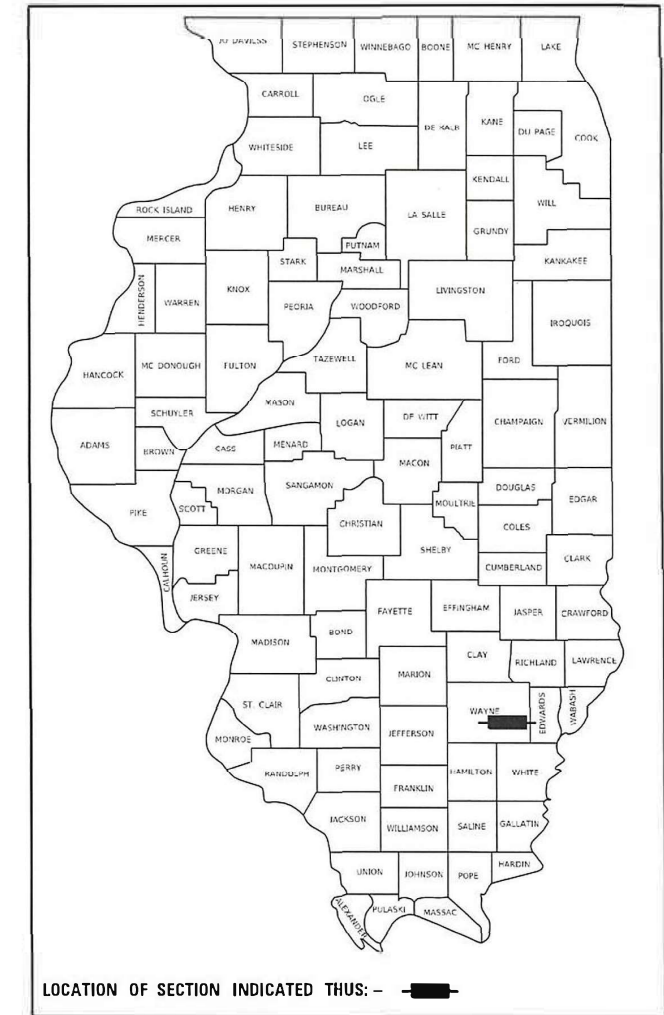

FULL SIZE PLANS HAVE BEEN PREPARED USING STANDARD ENGINEERING SCALES. REDUCED SIZED PLANS WILL NOT CONFORM TO STANDARD SCALES. IN MAKING MEASUREMENTS ON REDUCED PLANS, THE ABOVE SCALES MAY BE USED.

J.U.L.I.E.
JOINT UTILITY LOCATION INFORMATION FOR EXCAVATORS
1-800-892-0123
OR 811

PROJECT ENGINEER: JACQUELYN SEALS
PROJECT MANAGER: LEAH HILLE

CONTRACT NO. 74857

GROSS LENGTH = 663.0 FT. = 0.13 MILE
NET LENGTH = 663.0 FT. = 0.13 MILE

STATE OF ILLINOIS
DEPARTMENT OF TRANSPORTATION

SUBMITTED JANUARY 31 20 24
Jeffrey P. Myers REGIONAL ENGINEER
March 22, 2024
[Signature]
ENGINEER OF DESIGN AND ENVIRONMENT
March 22, 2024
[Signature]
DIRECTOR OF HIGHWAYS PROJECT IMPLEMENTATION

PRINTED BY THE AUTHORITY
OF THE STATE OF ILLINOIS

GENERAL NOTES

THIS PROJECT IS LOCATED ON FAP ROUTE 823 (ILL 15) IN WAYNE COUNTY, 0.4 MILES WEST OF 2095E EAST OF FAIRFIELD OVER POND CREEK. THE WORK INCLUDED IN SECTION (24BR-1)BR CONSISTS OF A SUPERSTRUCTURE REPLACEMENT.

THE LOCATION OF ONE (1) NEW PERMANENT SURVEY MARKER IS TO BE DETERMINED BY THE RESIDENT ENGINEER. THIS MARKER SHALL BE AN IDOT ALUMINUM DISK, CAST-IN-PLACE IN THE NEW STRUCTURE.

TEMPORARY CONCRETE BARRIER WILL NOT BE ALLOWED ON THE PAVEMENT BETWEEN DECEMBER 1 AND MARCH 1.

THE REMOVAL OF TEMPORARY RAMPS SHALL BE INCLUDED IN THE COST OF TEMPORARY RAMP.

ALL ELEVATIONS SHOWN IN PLANS ARE BASED ON U.S.G.S. DATUM.

MATERIAL FOR AGGREGATE SHOULDER, TYPE A SHALL BE CRUSHED STONE OR CRUSHED CONCRETE.

WHEN APPLYING SHORT TERM PAVEMENT MARKINGS, TEMPORARY TAPE SHALL BE USED ON THE SURFACE COURSES AND PAINT SHALL BE USED ON MILLED SURFACES.

PIPE DRAINS FOUR (4) INCHES SHALL BE ATTACHED TO PIPE UNDERDRAINS FOR STRUCTURES AND SHALL EXTEND TO THE BOTTOM OF THE EMBANKMENT SLOPE AND TERMINATE WITH A CONCRETE HEADWALL.

THE RESIDENT ENGINEER SHALL BE THE SOLE JUDGE CONCERNING THE CURING TIME FOR THE VARIOUS HOT-MIX ASPHALT LIFTS.

THE LOCATIONS AND/OR DEPTHS OF UNDERGROUND UTILITIES SHOWN HAVE BEEN TAKEN FROM INFORMATION FURNISHED BY THE UTILITY OWNERS AND MUST BE CONSIDERED APPROXIMATE. FIELD MARKINGS OF FACILITIES IN CRITICAL AREAS MAY BE OBTAINED BY PROVIDING MINIMUM OF FORTY-EIGHT (48) HOURS ADVANCE NOTICE THROUGH THE J.U.L.I.E. SYSTEM BY CALLING 800-892-0123.

UTILITIES IN THE PROJECT AREA

NAME/ADDRESS OF UTILITY COMPANY	TYPE	LOCATION OF CONFLICT	EST. DATE OF RELOCATION
CITY OF FAIRFIELD ATTN: BRAD YOUNG PHONE: 618.842.7015 (OFFICE) - 618.599.6632 (CELL) EMAIL: waterdept@fairfieldilcity.gov.us	WATER	EXPOSED WATER PIPE STATION 756+00-758+00 NORTH	PRIOR TO CONSTRUCTION (APPROX. JUNE 1, 2024)
FRONTIER COMMUNICATIONS ATTN: JAMES CLARK PHONE: 618.382.2887 (OFFICE) - 217.994.3841 (CELL) EMAIL: james.clark@ftr.com	FIBER	CONTACT INFORMATION ONLY	
NEW WAVE COMMUNICATIONS ATTN: JOEL HARRELSON PHONE: 812.895.7653 (OFFICE) - 618.383.2650 (CELL) EMAIL: jharrelson@newwavecom.com	FIBER	CONTACT INFORMATION ONLY	
WAYNE-WHITE ELECTRIC ATTN: JOSH SCOTT PHONE: 618.842.2196 EMAIL: jscott@wwcec.com	ELECTRIC	CONTACT INFORMATION ONLY	

APPLICATION RATES

THE FOLLOWING APPLICATION RATES WERE USED IN CALCULATING PLAN QUANTITIES AND HAVE BEEN INCLUDED FOR REFERENCE:

BITUMINOUS MATERIALS (TACK COAT)	0.05 LB/SQ FT (ON MILLED SURFACES)
	0.025 LB/SQ FT (ON HMA LIFTS)
RIP-RAP	1.485 TONS/CU YD
AGGREGATE SURFACE COURSE AND SHOULDER	2.05 TON/CU YD

MIXTURE REQUIREMENTS

THE FOLLOWING MIXTURE REQUIREMENTS ARE APPLICABLE TO THIS PROJECT:

LOCATION(S)	MIXTURE USE(S)	PG	DESIGN AIR VOIDS	MIXTURE COMPOSITION	FRICTION AGGREGATE	MIXTURE WEIGHT	QUALITY MANAGEMENT PROGRAM	SUBLOT SIZE	MATERIAL TRANSFER DEVICE (REQUIRED?)
MAINLINE	HMA SURFACE COURSE, IL-9.5, MIX "C", N70	PG 64-22	4.0% @ N=70	IL - 9.5	MIXTURE C	N70	QC/QA	3000	N/A
MAINLINE	HMA BINDER COURSE, IL-19.0, N70	PG 64-22	4.0% @ N=70	IL - 19.0	N/A	N70	QC/QA	3000	N/A
PAVEMENT CONNECTOR	HMA SURFACE COURSE, IL-9.5, MIX "C", N70 (TOP LIFT)	PG 64-22	4.0% @ N=70	IL - 9.5	MIXTURE C	N70	QC/QA	3000	N/A
PAVEMENT CONNECTOR	HMA BINDER COURSE, IL-19.0, N70 (BOTTOM LIFTS)	PG 64-22	4.0% @ N=70	IL - 19.0	N/A	N70	QC/QA	3000	N/A
WIDENING	HMA BINDER COURSE, IL-19.0, N70	PG 64-22	4.0% @ N=70	IL - 19.0	N/A	N70	QC/QA	3000	N/A

INDEX OF SHEETS

SHEET NO.	ITEM
1	COVER SHEET
2	INDEX OF SHEETS, LIST OF STANDARDS, AND GENERAL NOTES
3-5	SUMMARY OF QUANTITIES
6-8	TYPICAL SECTIONS
9-10	SCHEDULE OF QUANTITIES
11-12	PLAN AND PROFILE SHEET
13	EROSION CONTROL SHEET
14-15	STAGE 1 CONSTRUCTION
16	STAGE 2 CONSTRUCTION
17-18	POST-STAGE CONSTRUCTION
19-39	STRUCTURE PLANS
40-44	DISTRICT 7 DETAIL SHEETS
45-57	CROSS SECTION SHEETS

THE FOLLOWING STANDARDS ARE A PART OF THESE PLANS AND ARE INCLUDED AFTER SHEET NO. 57:

STANDARD NO.	DESCRIPTION
000001-08	STANDARD SYMBOLS, ABBREVIATIONS AND PATTERNS
001001-02	AREAS OF REINFORCEMENT BARS
001006	DECIMAL OF AN INCH AND OF A FOOT
280001-07	TEMPORARY EROSION CONTROL SYSTEMS
406201-01	MAILBOX TURNOUT
420001-10	PAVEMENT JOINTS
420406	PAVEMENT CONNECTOR (HMA) FOR BRIDGE APPROACH SLAB
515001-04	NAME PLATE FOR BRIDGES
601001-05	PIPE UNDERDRAINS
601101-02	CONCRETE HEADWALL FOR PIPE UNDERDRAINS
630001-13	STEEL PLATE BEAM GUARDRAIL
630201-07	PCC/HMA STABILIZATION AT STEEL PLATE BEAM GUARDRAIL SHOULDER
630301-09	WIDENING FOR TYPE 1 (SPECIAL) GUARDRAIL TERMINALS TRAFFIC
631061-01	BARRIER TERMINAL, TYPE 13
667101-02	PERMANENT SURVEY MARKERS
701001-02	OFF-ROAD OPERATIONS, 2L, 2W, MORE THAN 15' AWAY
701006-05	OFF-ROAD OPERATIONS, 2L, 2W, 15' TO 24' FROM PAVEMENT EDGE
701201-05	LANE CLOSURE, 2L, 2W, DAY ONLY, FOR SPEED ≥ 45 MPH
701301-04	LANE CLOSURE, 2L, 2W, SHORT TIME OPERATIONS
701311-03	LANE CLOSURE, 2L, 2W, MOVING OPERATIONS - DAY ONLY
701316-13	LANE CLOSURE, 2L, 2W, BRIDGE REPAIR, FOR SPEEDS ≥ 45 MPH
701321-18	LANE CLOSURE, 2L, 2W, BRIDGE REPAIR WITH BARRIER
701326-04	LANE CLOSURE, 2L, 2W, PAVEMENT WIDENING, FOR SPEEDS ≥ 45 MPH
701901-09	TRAFFIC CONTROL DEVICES
704001-08	TEMPORARY CONCRETE BARRIER
725001-01	OBJECT AND TERMINAL MARKERS
780001-05	TYPICAL PAVEMENT MARKINGS
782006-01	GUARDRAIL AND BARRIER WALL REFLECTOR MOUNTING DETAILS

REV. - MS

STATE OF ILLINOIS
DEPARTMENT OF TRANSPORTATION

INDEX OF SHEETS & GENERAL NOTES

F.A.P. RTE.	SECTION	COUNTY	TOTAL SHEETS	SHEET NO.
823	(24BR-1)BR	WAYNE	57	2
			CONTRACT NO. 74857	
ILLINOIS FED. AID PROJECT				

SCALE: NO SCALE SHEET 1 OF 1 SHEETS STA. TO STA.

MODEL: Default
FILE: Mainfile
PLOT DATE: 2/1/2024
PLOT SCALE: = 100.0000" / in.
DESIGNED: LMH
DRAWN: LMH
CHECKED: [blank]
DATE: 2/1/2024
REVISED: [blank]

SUMMARY OF QUANTITIES			TOTAL QUANTITIES	CONSTRUCTION TYPE CODE		
CODE NO	ITEM	UNIT		0010 80% FEDERAL 20% STATE		
20200100	EARTH EXCAVATION	CU YD	17	17		
20300100	CHANNEL EXCAVATION	CU YD	822	822		
20400800	FURNISHED EXCAVATION	CU YD	157	157		
21101505	TOPSOIL EXCAVATION AND PLACEMENT	CU YD	591	591		
25000200	SEEDING, CLASS 2	ACRE	0.5	0.5		
25000400	NITROGEN FERTILIZER NUTRIENT	POUND	40	40		
25000500	PHOSPHORUS FERTILIZER NUTRIENT	POUND	40	40		
25000600	POTASSIUM FERTILIZER NUTRIENT	POUND	40	40		
25100115	MULCH, METHOD 2	ACRE	0.5	0.5		
28000250	TEMPORARY EROSION CONTROL SEEDING	POUND	45	45		
28000400	PERIMETER EROSION BARRIER	FOOT	1020	1020		
28100109	STONE RIPRAP, CLASS A5	SQ YD	742	742		
28200200	FILTER FABRIC	SQ YD	742	742		
35600716	HOT-MIX ASPHALT BASE COURSE WIDENING, 10"	SQ YD	1167	1167		

SUMMARY OF QUANTITIES			TOTAL QUANTITIES	CONSTRUCTION TYPE CODE		
CODE NO	ITEM	UNIT		0010 80% FEDERAL 20% STATE		
40600290	BITUMINOUS MATERIALS (TACK COAT)	POUND	1380	1380		
40600990	TEMPORARY RAMP	SQ YD	615	615		
40603085	HOT-MIX ASPHALT BINDER COURSE, IL-19.0, N70	TON	300	300		
40604052	HOT-MIX ASPHALT SURFACE COURSE, IL-9.5, MIX "C", N70	TON	230	230		
42000070	PAVEMENT CONNECTOR (HMA) FOR BRIDGE APPROACH SLAB	SQ YD	114	114		
44000100	PAVEMENT REMOVAL	SQ YD	74	74		
48101200	AGGREGATE SHOULDERS, TYPE B	TON	110	110		
50101500	REMOVAL OF EXISTING SUPERSTRUCTURES	EACH	1	1		
50200100	STRUCTURE EXCAVATION	CU YD	64	64		
50300225	CONCRETE STRUCTURES	CU YD	21.7	21.7		
50300255	CONCRETE SUPERSTRUCTURE	CU YD	143.6	143.6		
50300260	BRIDGE DECK GROOVING	SQ YD	474	474		

* SPECIALTY ITEM

REV. - MS

MODEL: Default
 FILE: M:\MSA - Proj\Budget-aw-behler.com\PROJECTS\DOT Office\District 7\Projects\74857\CADD\Drawings\CAD\Drawings\74857-SP-S00.dgn

USER NAME = jessica.hille	DESIGNED - LMH	REVISED -
	DRAWN - LMH	REVISED -
PLOT SCALE = 100.0000' / in.	CHECKED -	REVISED -
PLOT DATE = 2/1/2024	DATE - 2/1/2024	REVISED -

**STATE OF ILLINOIS
DEPARTMENT OF TRANSPORTATION**

SUMMARY OF QUANTITIES

SCALE: NO SCALE SHEET 1 OF 3 SHEETS STA. TO STA.

F.A.P. RTE.	SECTION	COUNTY	TOTAL SHEETS	SHEET NO.
823	(24BR-1)BR	WAYNE	57	3
CONTRACT NO. 74857			ILLINOIS FED. AID PROJECT	

SUMMARY OF QUANTITIES			TOTAL QUANTITIES	CONSTRUCTION TYPE CODE		
CODE NO	ITEM	UNIT		0010 80% FEDERAL 20% STATE		
50300300	PROTECTIVE COAT	SQ YD	504	504		
50301350	CONCRETE SUPERSTRUCTURE (APPROACH SLAB)	CU YD	95.4	95.4		
50800205	REINFORCEMENT BARS, EPOXY COATED	POUND	84660	84660		
50800515	BAR SPLICERS	EACH	506	506		
50900211	STEEL RAILING, TYPE IL-OH	FOOT	199	199		
51500100	NAME PLATES	EACH	1	1		
58600101	GRANULAR BACKFILL FOR STRUCTURES	CU YD	37	37		
59100100	GEOCOMPOSITE WALL DRAIN	SQ YD	33	33		
60100060	CONCRETE HEADWALLS FOR PIPE DRAINS	EACH	4	4		
60146304	PIPE UNDERDRAINS FOR STRUCTURES 4"	FOOT	107	107		
63000001	STEEL PLATE BEAM GUARDRAIL, TYPE A, 6 FOOT POSTS	FOOT	107	107		
63100117	TRAFFIC BARRIER TERMINAL, TYPE 13	EACH	4	4		
63100167	TRAFFIC BARRIER TERMINAL, TYPE 1 (SPECIAL) TANGENT	EACH	2	2		

SUMMARY OF QUANTITIES			TOTAL QUANTITIES	CONSTRUCTION TYPE CODE		
CODE NO	ITEM	UNIT		0010 80% FEDERAL 20% STATE		
63100169	TRAFFIC BARRIER TERMINAL, TYPE 1 (SPECIAL) FLARED	EACH	2	2		
63200310	GUARDRAIL REMOVAL	FOOT	471	471		
67000400	ENGINEER'S FIELD OFFICE, TYPE A	CAL MO	6	6		
67100100	MOBILIZATION	L SUM	1	1		
70100100	TRAFFIC CONTROL AND PROTECTION, STANDARD 701316	EACH	1	1		
70100405	TRAFFIC CONTROL AND PROTECTION, STANDARD 701321	EACH	1	1		
70100450	TRAFFIC CONTROL AND PROTECTION, STANDARD 701201	L SUM	1	1		
70100500	TRAFFIC CONTROL AND PROTECTION, STANDARD 701326	L SUM	1	1		
70103815	TRAFFIC CONTROL SURVEILLANCE	CAL DA	3	3		
70106500	TEMPORARY BRIDGE TRAFFIC SIGNALS	EACH	1	1		
70106700	TEMPORARY RUMBLE STRIPS	EACH	3	3		

* SPECIALTY ITEM

REV. - MS

MODEL: Default
 FILE: M:\MS_E_Plan\Budget-aw_bentley.com\PROJECTS\DOT_Offices\District_7\Projects\74857\CADD\Drawings\74857-SP-S00.dgn

USER NAME = jessica.hille	DESIGNED - LMH	REVISED -
	DRAWN - LMH	REVISED -
PLOT SCALE = 100.0000' / in.	CHECKED -	REVISED -
PLOT DATE = 2/1/2024	DATE - 2/1/2024	REVISED -

**STATE OF ILLINOIS
DEPARTMENT OF TRANSPORTATION**

SUMMARY OF QUANTITIES

SCALE: NO SCALE SHEET 2 OF 3 SHEETS STA. TO STA.

F.A.P. RTE. 823	SECTION (24BR-1)BR	COUNTY WAYNE	TOTAL SHEETS 57	SHEET NO. 4
CONTRACT NO. 74857			ILLINOIS FED. AID PROJECT	

SUMMARY OF QUANTITIES			TOTAL QUANTITIES	CONSTRUCTION TYPE CODE		
CODE NO	ITEM	UNIT		0010 80% FEDERAL 20% STATE		
70107005	PAVEMENT MARKING BLACKOUT TAPE, 5"	FOOT	1235	1235		
70107025	CHANGEABLE MESSAGE SIGN	CAL DA	28	28		
70300100	SHORT TERM PAVEMENT MARKING	FOOT	200	200		
70300150	SHORT TERM PAVEMENT MARKING REMOVAL	SQ FT	540	540		
70300221	TEMPORARY PAVEMENT MARKING - LINE 4"- PAINT	FOOT	1750	1750		
70400100	TEMPORARY CONCRETE BARRIER	FOOT	450	450		
70400125	PINNING TEMPORARY CONCRETE BARRIER	EACH	81	81		
70400200	RELOCATE TEMPORARY CONCRETE BARRIER	FOOT	362.5	362.5		
70600250	IMPACT ATTENUATORS, TEMPORARY (NON-REDIRECTIVE), TEST LEVEL 3	EACH	2	2		
70600260	IMPACT ATTENUATORS, TEMPORARY (FULLY REDIRECTIVE, NARROW), TEST LEVEL 3	EACH	2	2		
70600332	IMPACT ATTENUATORS, RELOCATE (FULLY REDIRECTIVE, NARROW), TEST LEVEL 3	EACH	2	2		
70600350	IMPACT ATTENUATORS, RELOCATE (NON-REDIRECTIVE), TEST LEVEL 3	EACH	2	2		

SUMMARY OF QUANTITIES			TOTAL QUANTITIES	CONSTRUCTION TYPE CODE		
CODE NO	ITEM	UNIT		0010 80% FEDERAL 20% STATE		
* 72501000	TERMINAL MARKER - DIRECT APPLIED	EACH	4	4		
* 78001110	PAINT PAVEMENT MARKING - LINE 4"	FOOT	1750	1750		
* 78200005	GUARDRAIL REFLECTORS, TYPE A	EACH	16	16		
78300200	RAISED REFLECTIVE PAVEMENT MARKER REMOVAL	EACH	7	7		
X0326440	SURFACE REMOVAL, VARIABLE DEPTH (SPECIAL)	SQ YD	107	107		
X4060995	TEMPORARY RAMP (SPECIAL)	SQ YD	54	54		
X4401198	HOT-MIX ASPHALT SURFACE REMOVAL, VARIABLE DEPTH	SQ YD	1924	1924		
Z0004552	APPROACH SLAB REMOVAL	SQ YD	227	227		
Z0049799	PROTECTING OR RESETTING SURVEY MARKERS	EACH	1	1		
X1200235	REMOVE EXISTING RIPRAP	CU YD	121	121		
52200010	TEMPORARY SHEET PILING	SQ FT	175	175		

* SPECIALTY ITEM

REV. - MS

MODEL: Default
FILE: M:\MS_E_P\11482624w_bentley.com\FWIDOT\Documents\DOT_Offices\District_7\Projects\74857\CaddData\Cadd\Sheets\074857-01-SC00.dgn

USER NAME = jessica.hille	DESIGNED - LMH	REVISED -
	DRAWN - LMH	REVISED -
PLOT SCALE = 100.0000' / in.	CHECKED -	REVISED -
PLOT DATE = 2/1/2024	DATE - 2/1/2024	REVISED -

**STATE OF ILLINOIS
DEPARTMENT OF TRANSPORTATION**

SUMMARY OF QUANTITIES

SCALE: NO SCALE SHEET 3 OF 3 SHEETS STA. TO STA.

F.A.P. RTE.	SECTION	COUNTY	TOTAL SHEETS	SHEET NO.
823	(24BR-1)BR	WAYNE	57	5
CONTRACT NO. 74857			ILLINOIS FED. AID PROJECT	

EXISTING TYPICAL CROSS SECTIONS (ILL 15)

STATION 754+37 TO STATION 755+81.5

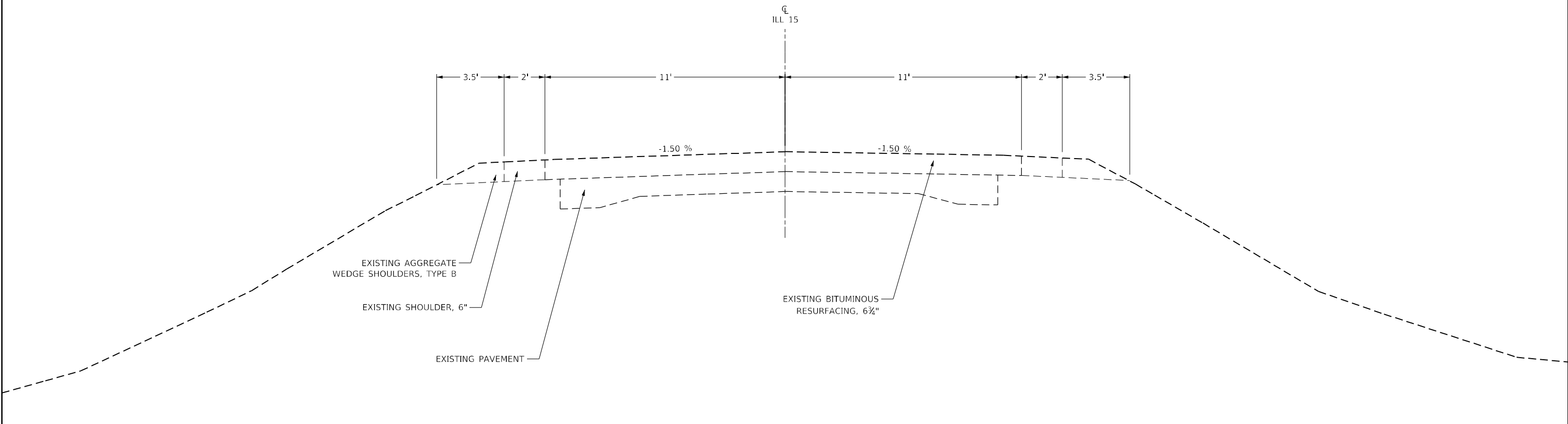

PROPOSED TYPICAL CROSS SECTIONS (ILL 15)

STATION 754+37 TO STATION 755+81.5

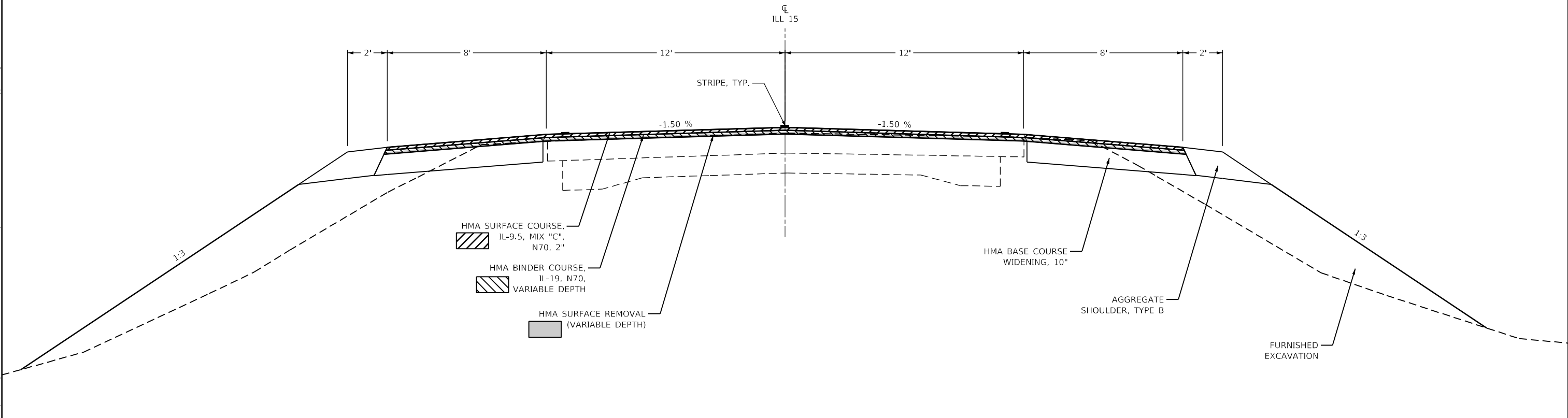

MODEL: Default
 FILE: \\mari...\\public\\aw.bentley.com\\P\\I\\DOT\\Documents\\DOT Office\\Director_7\\Project\\74857\\CAD\\Data\\CAD\\sheets\\D74857-111-111-111.dgn

USER NAME = jessica.hille	DESIGNED - LMH	REVISED -
	DRAWN - LMH	REVISED -
PLOT SCALE = 100,0000' / in.	CHECKED -	REVISED -
PLOT DATE = 2/1/2024	DATE - 2/1/2024	REVISED -

**STATE OF ILLINOIS
DEPARTMENT OF TRANSPORTATION**

TYPICAL CROSS SECTIONS

SCALE: NO SCALE SHEET 1 OF 3 SHEETS STA. 754+37 TO STA. 755+81.5

F.A.P. RTE. 823	SECTION (24BR-1)BR	COUNTY WAYNE	TOTAL SHEETS 57	SHEET NO. 6
CONTRACT NO. 74857			ILLINOIS FED. AID PROJECT	

EXISTING TYPICAL CROSS SECTIONS (ILL 15)

STATION 757+45 TO STATION 758+75

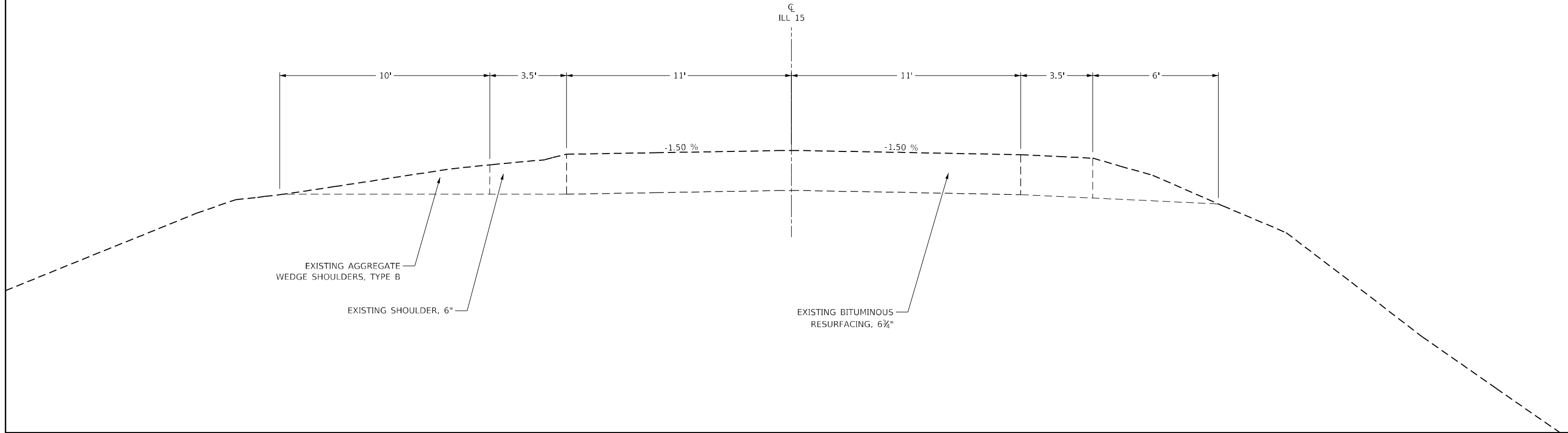

PROPOSED TYPICAL CROSS SECTIONS (ILL 15)

STATION 757+45 TO STATION 758+75

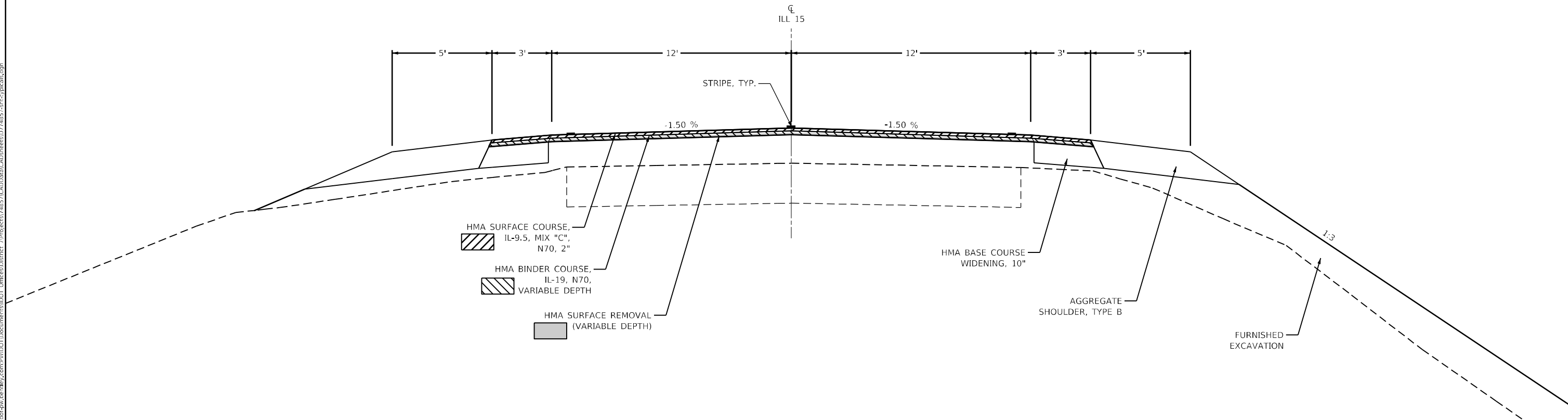

- HMA SURFACE COURSE, IL-9.5, MIX "C", N70, 2"
- HMA BINDER COURSE, IL-19, N70, VARIABLE DEPTH
- HMA SURFACE REMOVAL (VARIABLE DEPTH)

MODEL: Default
 FILE: hmlr.ctb
 PLOT DATE: 2/1/2024
 PLOT SCALE: 100,0000' / in.
 USER NAME: jessica.hille
 DESIGNED - LMH
 DRAWN - LMH
 CHECKED -
 DATE - 2/1/2024
 REVISED -
 REVISED -
 REVISED -
 REVISED -

STATE OF ILLINOIS
DEPARTMENT OF TRANSPORTATION

TYPICAL CROSS SECTIONS

SCALE: NO SCALE SHEET 2 OF 3 SHEETS STA. 757+45 TO STA. 758+75

F.A.P. RTE.	SECTION	COUNTY	TOTAL SHEETS	SHEET NO.
823	(24BR-1)BR	WAYNE	57	7
CONTRACT NO. 74857				
ILLINOIS FED. AID PROJECT				

EXISTING TYPICAL CROSS SECTIONS (ILL 15)

STATION 758+75 TO STATION 761+00

CL
ILL 15

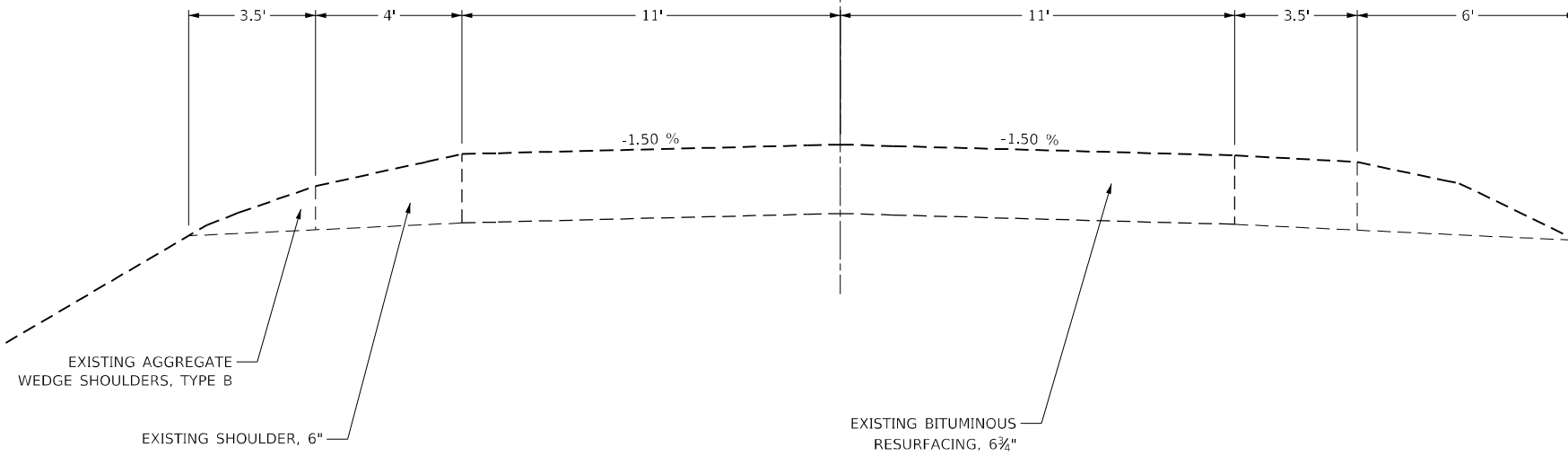

PROPOSED TYPICAL CROSS SECTIONS (ILL 15)

STATION 758+75 TO STATION 761+00

CL
ILL 15

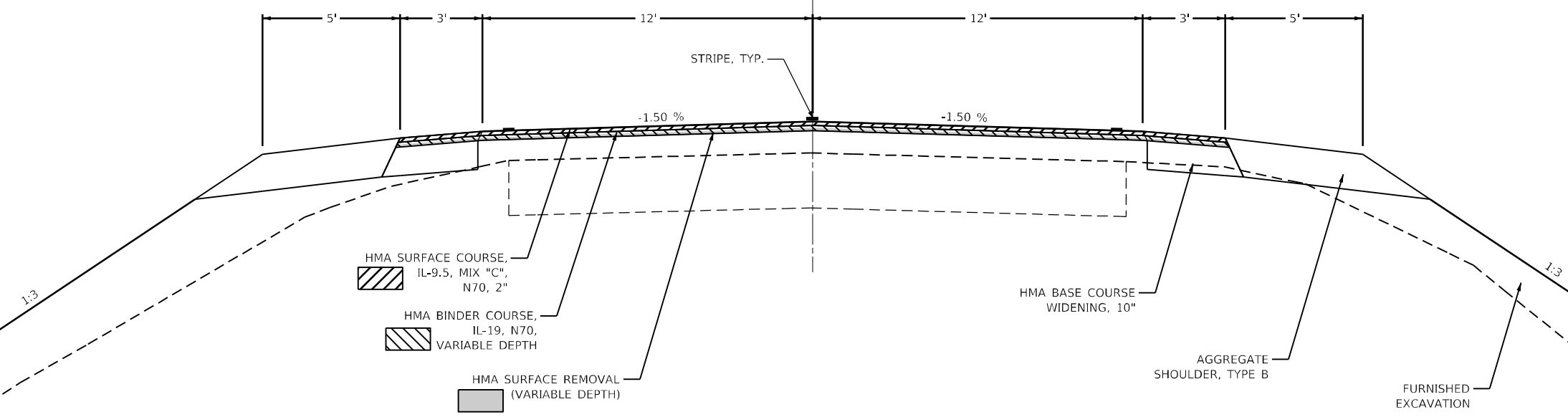

MODEL: Default
FILE: hmlr15_24482.dwg
PROJECT: 74857
DOCUMENT: 11001
OFFICE: District 7
PROJECT: 74857
CADD: Data/CADD/Sheet/074857-8-15-24.dgn

USER NAME = jessica.hille	DESIGNED - LMH	REVISED -
DRAWN - LMH	REVISOR -	
PLOT SCALE = 100,0000' / in.	CHECKED -	REVISOR -
PLOT DATE = 2/1/2024	DATE - 2/1/2024	REVISOR -

STATE OF ILLINOIS
DEPARTMENT OF TRANSPORTATION

TYPICAL CROSS SECTIONS

SCALE: NO SCALE SHEET 3 OF 3 SHEETS STA. 758+75 TO STA. 761+00

F.A.P. RTE.	SECTION	COUNTY	TOTAL SHEETS	SHEET NO.
823	(24BR-1)BR	WAYNE	57	8
CONTRACT NO. 74857				
ILLINOIS FED. AID PROJECT				

MODEL: Default
 FILE: \\mfe-pw-backend.com\P\INDOT\Documents\DOT_Offices\Director_7\Projects\74857\CADD\Bids\CAD\sheet\074857-sh-sched.tbl.dgn

STATION	EXISTING ELEVATION	PROPOSED ELEVATION	MILLING SCHEDULE			
			ELEVATION DIFFERENCE	SURFACE THICKNESS	BINDER THICKNESS	MILLING THICKNESS
754+00	416.98	416.98	0	0.17	0	0.17
754+25	417.13	417.13	0	0.17	0	0.17
754+37	417.26	417.26	0	0.17	0	0.17
754+50	417.27	417.28	0.01	0.17	0	0.16
754+75	417.28	417.31	0.02	0.17	0	0.14
755+00	417.30	417.33	0.03	0.17	0	0.14
755+25	417.39	417.36	-0.03	0.17	0	0.20
755+50	417.49	417.38	-0.11	0.17	0	0.28
755+75	417.55	417.40	-0.15	0.17	0	0.32
755+82	417.54	417.40	-0.14	0.17	0	0.31
BRIDGE OMISSION						
757+45	417.78	418.02	0.24	0.17	0.24	0.17
757+50	417.82	418.08	0.26	0.17	0.26	0.17
757+75	417.99	418.42	0.43	0.17	0.43	0.17
758+00	418.31	418.84	0.53	0.17	0.53	0.17
758+25	418.75	419.33	0.58	0.17	0.58	0.17
758+50	419.20	419.90	0.70	0.17	0.70	0.17
758+75	419.99	420.55	0.56	0.17	0.56	0.17
759+00	420.84	421.28	0.44	0.17	0.44	0.17
759+25	421.69	422.09	0.40	0.17	0.40	0.17
759+50	422.54	422.97	0.43	0.17	0.43	0.17
759+75	423.54	423.92	0.38	0.17	0.38	0.17
760+00	424.77	424.96	0.19	0.17	0.19	0.17
760+25	426.01	426.07	0.06	0.17	0.06	0.17
760+50	427.24	427.26	0.02	0.17	0.02	0.17
760+75	428.50	428.51	0.01	0.17	0.01	0.17
761+00	429.77	429.77	0	0.17	0	0.17
761+25	430.96	430.96	0	0.17	0	0.17
761+50	432.15	432.15	0	0.17	0	0.17

STAGING SCHEDULE			40600990 TEMPORARY RAMP	70106500 TEMPORARY BRIDGE TRAFFIC SIGNALS	70106700 TEMPORARY RUMBLE STRIPS	70400100 TEMPORARY CONCRETE BARRIER	70400125 PINNING TEMPORARY CONCRETE BARRIER	70400200 RELOCATE TEMPORARY CONCRETE BARRIER	70600250 IMPACT ATTENUATORS, TEMPORARY (NON-REDIRECTIVE), TEST LEVEL 3	70600260 IMPACT ATTENUATORS, TEMPORARY (FULLY-REDIRECTIVE, NARROW), TEST LEVEL 3	70600332 IMPACT ATTENUATORS, RELOCATE (FULLY-REDIRECTIVE, NARROW), TEST LEVEL 3	70600350 IMPACT ATTENUATORS, RELOCATE (NON-REDIRECTIVE), TEST LEVEL 3
STATION TO STATION	SQ YD	EACH	EACH	FOOT	EACH	FOOT	EACH	FOOT	EACH	EACH	EACH	EACH
STAGE 1 752+78.5 758+77.0	178.7	1.0	3.0	450.0	75.0	-	2.0	2.0	-	-	-	-
STAGE 2 754+90.5 760+02.5	435.6	-	-	362.5	6.0	362.5	-	-	-	2.0	2.0	-
TOTALS:	615	1	3	450	81	362.5	2	2	2	2	2	2

PERMANENT SURVEY MARKER SCHEDULE							Z0049799 PROTECTING OR RESETTling SURVEY MARKERS
NORTHING	EASTING	DESCRIPTION	STATION	O/S	PROPOSED PROTECT OR RESET	EACH	
623536.529	987229.102	PI-CHISLED "X" ON BRIDGE DECK	756+47.26	0	TYPE 1 - ALUM. DISK FLUSH	1	
TOTALS:							1

SHOULDER SCHEDULE				35600716 HOT-MIX ASPHALT BASE COURSE WIDENING, 10"	48101200 AGGREGATE SHOULDERS, TYPE B
STATION TO STATION	SO YD	TON	TON	TON	TON
RT 754+37 756+21	183	4			
LT 751+35 756+11	510	16			
LT 757+06 760+50	308	44			
RT 757+16 760+50	167	42			
TOTALS:	1167	110			

EROSION CONTROL SCHEDULE				28000400 PERIMETER EROSION BARRIER	28100109 STONE RIPRAP, CLASS A5	28200200 FILTER FABRIC
LOCATION	FOOT	SQ YD	SQ YD	SQ YD	SQ YD	SQ YD
NE QUADRANT	156.0	-	-	-	-	-
NW QUADRANT	388.0	-	-	-	-	-
SE QUADRANT	145.0	-	-	-	-	-
SW QUADRANT	328.0	-	-	-	-	-
QUANTITY FROM BR SHEETS	-	719.0	719.0	-	-	-
TOTALS:	1020	719	719			

EARTHWORK SCHEDULE				
STATION TO STATION	20200100 EARTH EXCAVATION CU YD	20300100 CHANNEL EXCAVATION CU YD	20400800 FURNISHED EXCAVATION CU YD	21101505 TOPSOIL EXCAVATION AND PLACEMENT CU YD
754+37 756+21	17	822	157	591
TOTALS:	17	822	157	591

USER NAME = jessica.hille	DESIGNED - LMH	REVISED -
DRAWN - LMH	REVISED -	
PLOT SCALE = 100,0000' / in.	CHECKED -	REVISED -
PLOT DATE = 2/1/2024	DATE - 2/1/2024	REVISED -

**STATE OF ILLINOIS
DEPARTMENT OF TRANSPORTATION**

SCHEDULE OF QUANTITIES			
SCALE: NO SCALE	SHEET 1	OF 2 SHEETS	STA. TO STA.

F.A.P. RTE. 823	SECTION (24BR-1)BR	COUNTY WAYNE	TOTAL SHEETS 57	SHEET NO. 9
CONTRACT NO. 74857				
ILLINOIS FED. AID PROJECT				

MODEL: Default
 FILE: \\bluest-pw-bentley.com\P\INDOT\Documents\DOT_Offices\Dir\rdt_7\Project\74857\CADD\Drawings\CAD\Drawings\74857-sh-seeded.lg.dgn

SEEDING SCHEDULE						
	25000200 SEEDING, CLASS 2	25000400 NITROGEN FERTILIZER NUTRIENT	25000500 PHOSPHORUS FERTILIZER NUTRIENT	25000600 POTASSIUM FERTILIZER NUTRIENT	25100115 MULCH, METHOD 2	28000250 TEMPORARY EROSION CONTROL SEEDING
LOCATION	ACRE	POUND	POUND	POUND	ACRE	POUND
NE QUADRANT	0.14	12.8	12.8	12.8	0.14	14.2
NW QUADRANT	0.22	19.4	19.4	19.4	0.22	21.5
SE QUADRANT	0.05	4.1	4.1	4.1	0.05	4.6
SW QUADRANT	0.04	3.6	3.6	3.6	0.04	4.0
TOTALS:	0.50	40	40	40	0.50	45

PAVEMENT MARKING SCHEDULE								
	70107005 PAVEMENT MARKING BLACKOUT TAPE, 5"	70300100 SHORT TERM PAVEMENT MARKING	70300150 SHORT TERM PAVEMENT MARKING REMOVAL	70300221 TEMPORARY PAVEMENT MARKING - LINE 4" - PAINT (WHITE)	70300221 TEMPORARY PAVEMENT MARKING - LINE 4" - PAINT (YELLOW)	78001110 PAINT PAVEMENT MARKING LINE 4" (WHITE)	78001110 PAINT PAVEMENT MARKING LINE 4" (YELLOW)	
STATION TO STATION	FOOT	FOOT	SQ FT	FOOT	FOOT	FOOT	FOOT	
STAGE 1	750+36.0	758+40.2	643	-	322	-	-	-
STAGE 2	753+21.8	759+65.0	593	-	193	-	-	-
MAINLINE	750+36.0	762+26.0	-	199	23	435	1256	485
TOTALS:			1235	200	540	1750		1750

ENTRANCE SCHEDULE						
	40603085 HOT-MIX ASPHALT BINDER COURSE, IL- 19.0, N70	40604052 HOT-MIX ASPHALT SURFACE COURSE, IL- 9.5, MIX "C", N70	X0326440 SURFACE REMOVAL, VARIABLE DEPTH (SPECIAL)	X4060995 TEMPORARY RAMP, SPECIAL		
STATION	LT/RT	TON	TON	SQ YD	SQ YD	
PRA	758+19.8	LT	45.3	12.0	106.9	53.3
TOTALS:			45.5	12	107	54

GUARDRAIL SCHEDULE								
	50900211 STEEL RAILING, TYPE IL-OH (FROM BRIDGE PLANS)	63000001 STEEL PLATE BEAM GUARDRAIL TYPE A, 6 FOOT POSTS	63100117 TRAFFIC BARRIER TERMINAL, TYPE 13	63100167 TRAFFIC BARRIER TERMINAL, TYPE 1 (SPECIAL) TANGENT	63100169 TRAFFIC BARRIER TERMINAL, TYPE 1 (SPECIAL) FLARED	63200310 GUARDRAIL REMOVAL	72501000 TERMINAL MARKER - DIRECT APPLIED	78200005 GUARDRAIL REFLECTORS, TYPE A
STATION TO STATION	FOOT	FOOT	EACH	EACH	EACH	FOOT	EACH	EACH
LT	755+16.1	755+53.6	-	1.0	-	139.0	1.0	4.0
	755+53.6	755+78.6	25.0	-	-			
	755+78.6	756+22.0	-	1.0	-			
RT	755+00.1	755+37.6	-	-	1.0	53.0	1.0	4.0
	755+37.6	755+87.6	50.0	-	-			
	755+87.6	756+31.0	-	1.0	-			
LT	756+95.5	757+38.9	-	1.0	-	140.0	1.0	4.0
	757+38.9	757+45.1	6.2	-	-			
	757+45.1	757+82.6	-	-	1.0			
RT	757+04.7	757+48.1	-	1.0	-	139.0	1.0	4.0
	757+48.1	757+73.1	25.0	-	-			
	757+73.1	758+10.6	-	-	-			
TOTALS:	199	107	4	2	2	471	4	16

PAVING SCHEDULE								
	40600290 BITUMINOUS MATERIALS TACK COAT	40603085 HOT-MIX ASPHALT BINDER COURSE, IL- 19.0, N70	40604052 HOT-MIX ASPHALT SURFACE COURSE, IL- 9.5, MIX "C", N70	42000070 PAVEMENT CONNECTOR (HMA) FOR BRIDGE APPROACH SLAB	44000100 PAVEMENT REMOVAL	78300200 RAISED REFLECTIVE PAVEMENT MARKER REMOVAL	X4401198 HOT-MIX ASPHALT SURFACE REMOVAL, VARIABLE DEPTH	Z0004552 APPROACH SLAB REMOVAL
STATION TO STATION	POUND	TON	TON	SQ YD	SQ YD	FACH	SQ YD	SQ YD
RT	754+37	756+21	429.8	0.0	71.3	36.7	1.8	636.6
LT	751+35	756+11						
LT	757+06	758+20	940.6	254.1	144.1	56.7	36.7	4.4
RT	757+16	758+57						
TOTALS:	1380	254.5	218	114	74	7	1924	227

USER NAME = Default	DESIGNED - LMH	REVISED -
	DRAWN - LMH	REVISED -
PLOT SCALE = 100,0000' / in.	CHECKED -	REVISED -
PLOT DATE = 2/22/2024	DATE - 2/22/2024	REVISED -

**STATE OF ILLINOIS
DEPARTMENT OF TRANSPORTATION**

SCHEDULE OF QUANTITIES			
SCALE:	SHEET	OF	SHEETS
NO SCALE	2	2	

F.A.P. RTE. 823	SECTION (24BR-1)BR	COUNTY WAYNE	TOTAL SHEETS 57	SHEET NO. 10
CONTRACT NO. 74857				
ILLINOIS FED. AID PROJECT				

PLAN	SURVEYED	DATE
	PLOTTED	
	ALIGNED	
	CHECKED	
	CADD FILE NAME	
	NO.	

PROFILE	SURVEYED	DATE
	PLOTTED	
	GRADES CHECKED	
	STRUCTURE NOTATIONS CHECKED	
	NO.	

MATCHLINE STATION 755 + 50

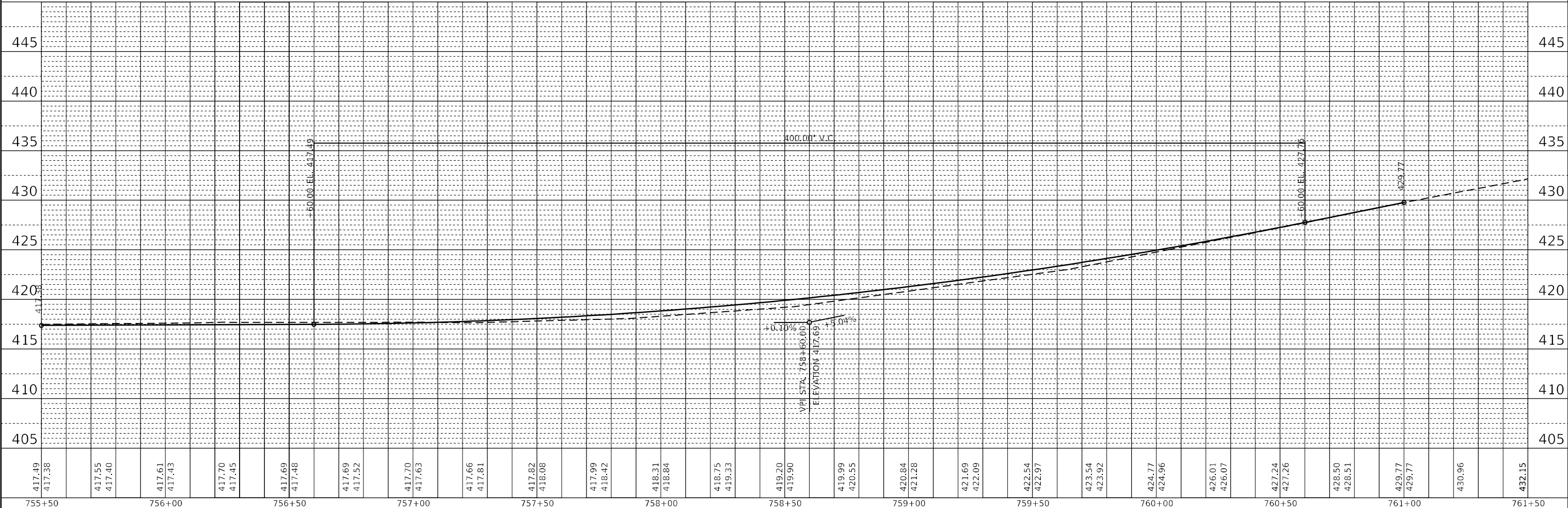
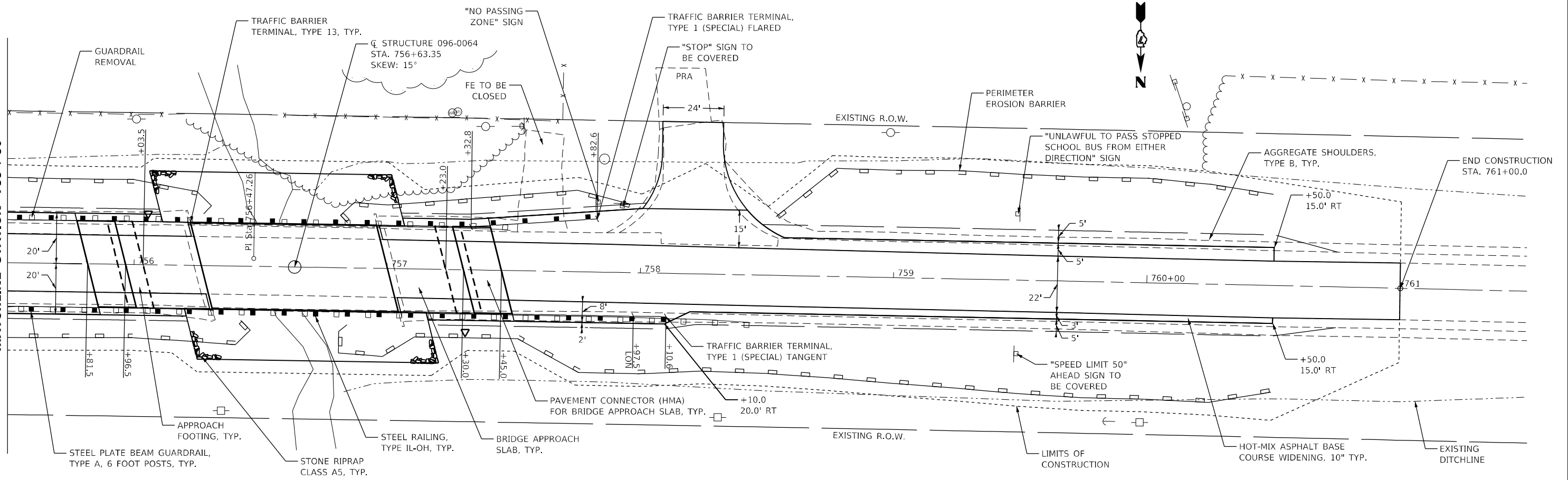

MODEL: Default
 FILE NAME: j:\Illinois\epw\berlin\com\p\WID\DOT\Documents\DOT_Offices\Burlin_P\Projects\74857\CADD\Drawings\74857-sr-pln.dwg

USER NAME = jessica.wille	DESIGNED - LMH	REVISED -
	DRAWN - LMH	REVISED -
PLOT SCALE = 40,0000 "/td> <td>CHECKED -</td> <td>REVISED -</td>	CHECKED -	REVISED -
PLOT DATE = 2/1/2024	DATE - 2/1/2024	REVISED -

**STATE OF ILLINOIS
DEPARTMENT OF TRANSPORTATION**

**PLAN & PROFILE SHEET
SN 096-0064**

F.A.P. RTE. 823	SECTION (248R-1)BR	COUNTY WAYNE	TOTAL SHEETS 57	SHEET NO. 12
CONTRACT NO. 74857			ILLINOIS FED. AID PROJECT	

SCALE: 40,0000 ' / in, SHEET 2 OF 2 SHEETS STA. 755+50 TO STA. 761+00

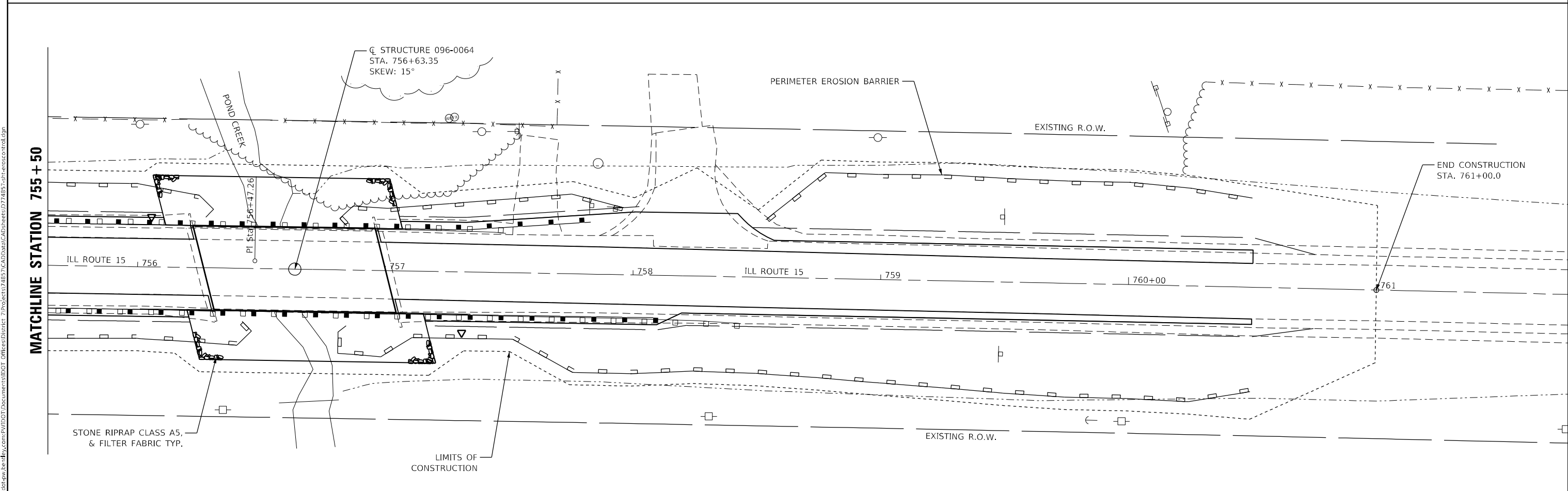
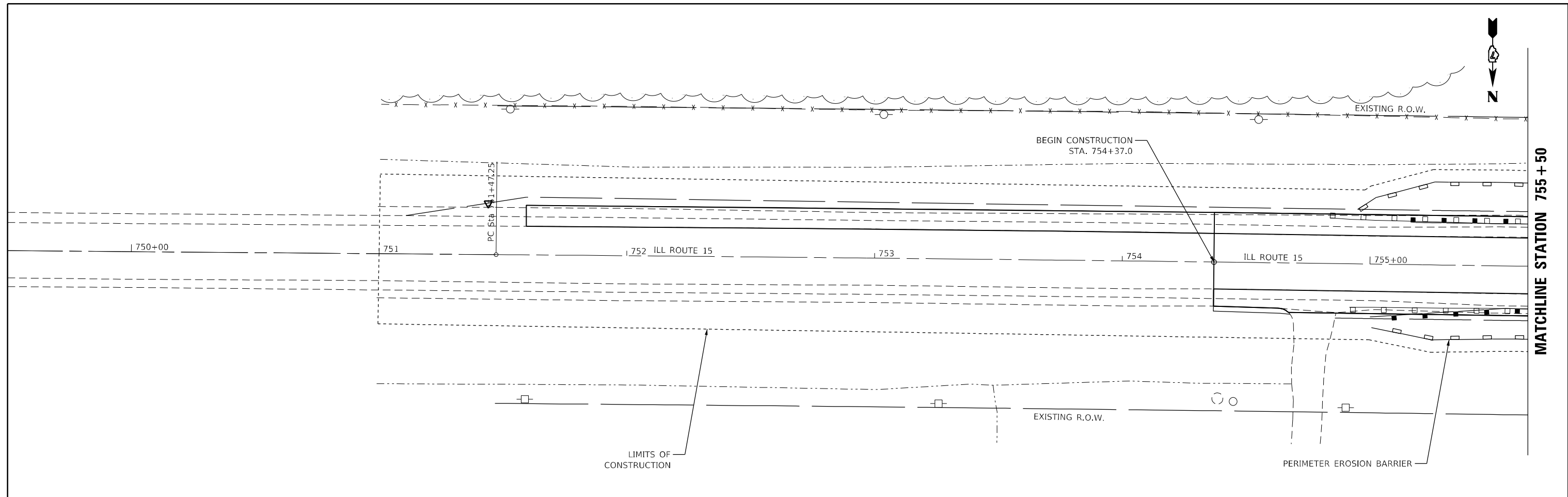

MODEL: Default
 FILE: \\blmfc-pw\subject-pw-beadefy.com\PI\DOT\Documents\DOT Office\Director_7\Projects\74857\CADD\Batt\CAD\sheet\074857-11-eroccontrol.dgn

MATCHLINE STATION 755 + 50

MATCHLINE STATION 755 + 50

USER NAME = jessica.hille	DESIGNED -	REVISED -
	DRAWN -	REVISED -
PLOT SCALE = 40,0000 ' / in.	CHECKED -	REVISED -
PLOT DATE = 2/1/2024	DATE -	REVISED -

STATE OF ILLINOIS
DEPARTMENT OF TRANSPORTATION

EROSION CONTROL PLAN

SCALE: 40,0000 ' / in. SHEET 1 OF 1 SHEETS STA. 754+37 TO STA. 761+00

F.A.P. RTE.	SECTION	COUNTY	TOTAL SHEETS	SHEET NO.
823	(24BR-1)BR	WAYNE	57	13
CONTRACT NO. 74857				
ILLINOIS FED. AID PROJECT				

LEGEND

	TYPE III BARRICADE WITH FLASHING LIGHTS		SIGN
	DRUM WITH STEADY BURNING BI-DIRECTIONAL LIGHT		TEMPORARY CONCRETE BARRIER
	TRAFFIC SIGNAL		WORK ZONE

NOTES:

PRE-STAGE: CONSTRUCT WIDENING ON SOUTH SIDE TO FACE OF EXISTING GUARDRAIL.
 SUGGESTED SEQUENCE OF STAGE 1 OPERATIONS:
 1. INSTALL TEMPORARY TRAFFIC SIGNALS.
 2. ACTIVATE TEMPORARY TRAFFIC SIGNALS.
 3. INSTALL TEMPORARY CONCRETE BARRIERS, TEMPORARY IMPACT ATTENUATORS, AND TRAFFIC CONTROL DEVICES ALONG ILL 15.
 4. CONSTRUCT THE STAGE 1 PORTION OF THE PROPOSED SUPERSTRUCTURE, BRIDGE APPROACH, PAVEMENT CONNECTOR, FURNISHED EXCAVATION, AND RIPRAP.
 5. CONSTRUCT HMA WIDENING, TEMPORARY RAMPS, AND GUARDRAIL ON THE NORTH SIDE.
 SEE TRAFFIC CONTROL AND PROTECTION STANDARD 701321 FOR INFORMATION NOT SHOWN ON THIS SHEET.

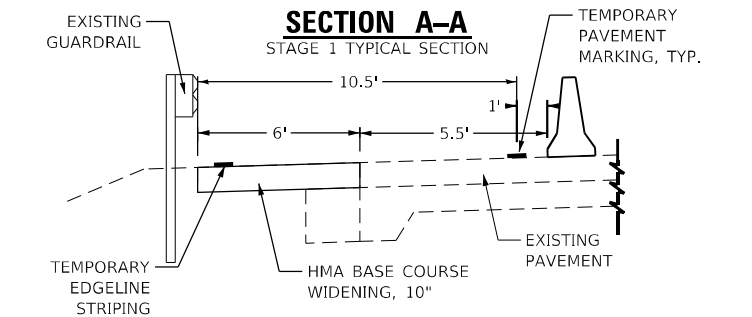

CONSTRUCT SIGNAGE AND DEVICES PER TRAFFIC CONTROL STANDARD 701321

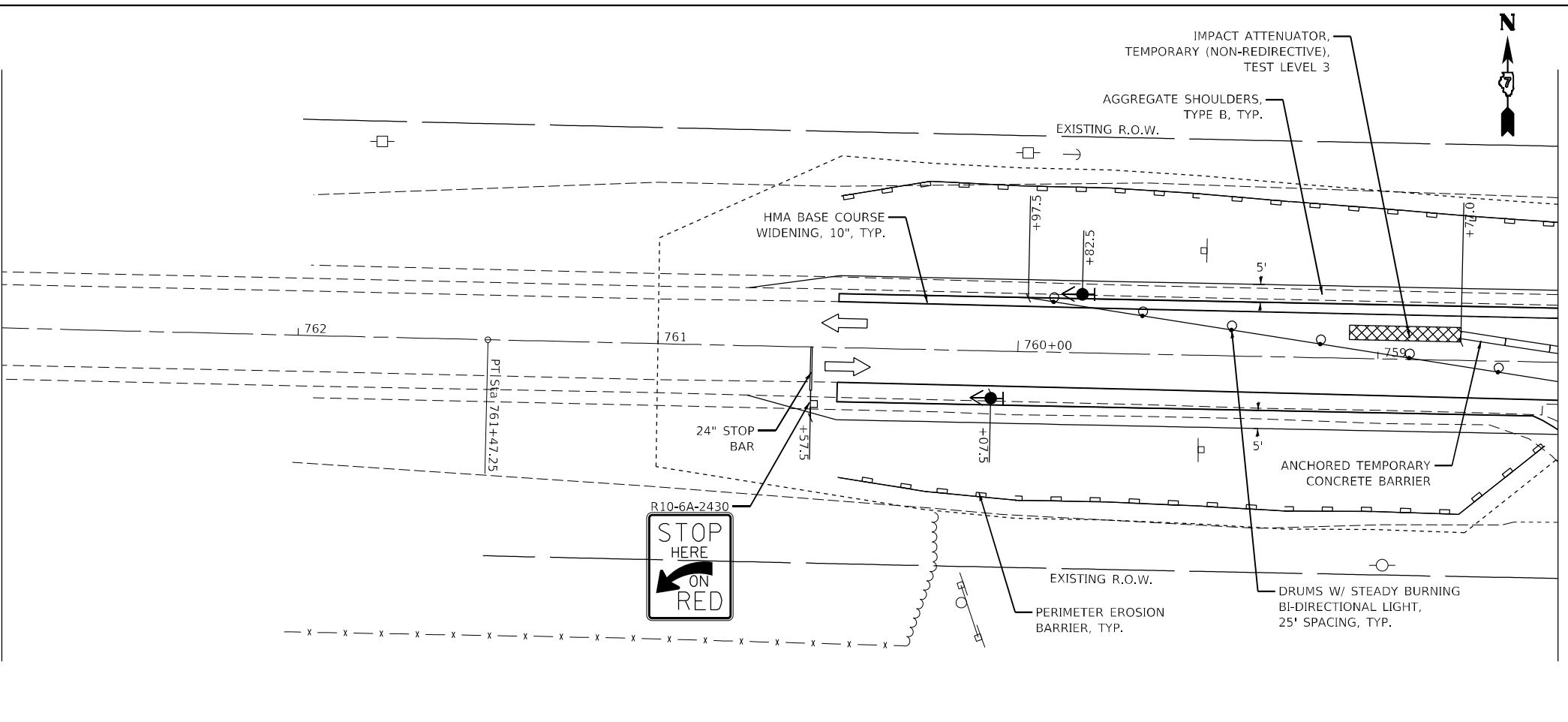

MATCHLINE STATION 758 + 50

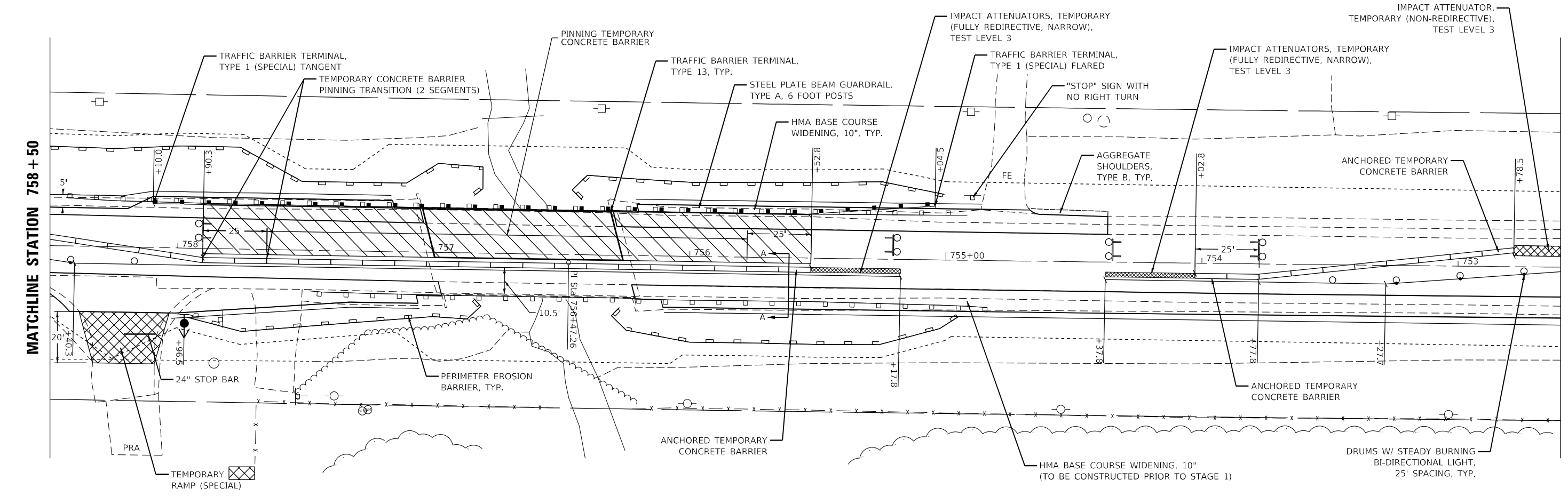

MATCHLINE STATION 758 + 50

MATCHLINE STATION 752 + 60

MODEL: Default
 FILE: 244857-101-Subcontract-Plan-View.dwg
 PROJECT: 244857-101-Subcontract-Plan-View.dwg
 PLOT DATE: 2/22/2024





USER NAME = Default	DESIGNED - LMH	REVISED -
PLOT SCALE = 40,0000' / in.	DRAWN - LMH	REVISED -
PLOT DATE = 2/22/2024	CHECKED -	REVISED -
	DATE - 2/22/2024	REVISED -

**STATE OF ILLINOIS
 DEPARTMENT OF TRANSPORTATION**

STAGE 1 TRAFFIC CONTROL STANDARD 701321	
SCALE: 40,0000' / in.	SHEET 1 OF 2 SHEETS STA. TO STA.

F.A.P. RTE. 823	SECTION (24BR-1)BR	COUNTY WAYNE	TOTAL SHEETS 57	SHEET NO. 14
CONTRACT NO. 74857				
ILLINOIS FED. AID PROJECT				

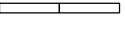
LEGEND

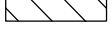
-  TYPE III BARRICADE WITH FLASHING LIGHTS
-  SIGN
-  DRUM WITH STEADY BURNING BI-DIRECTIONAL LIGHT
-  TEMPORARY CONCRETE BARRIER
-  TRAFFIC SIGNAL
-  WORK ZONE

MATCHLINE STATION 752 + 60

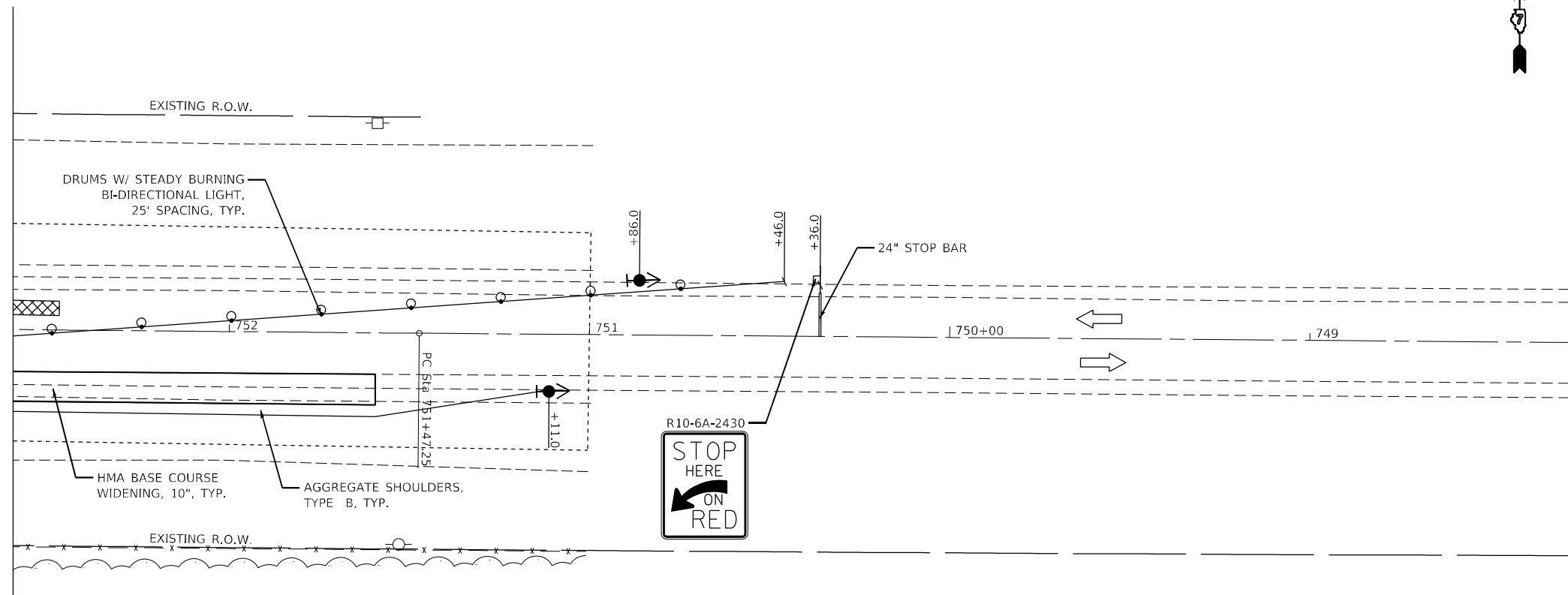

CONSTRUCT SIGNAGE AND DEVICES PER TRAFFIC CONTROL STANDARD 701321

MODEL: Default
FILE: \\mupc-pw\pwworkspace\bea\pwworkspace\Project\74857\CADD\Drawings\CAD\Drawings\74857-01-01.dwg

USER NAME = Default	DESIGNED - LMH	REVISED -
	DRAWN - LMH	REVISED -
PLOT SCALE = 40,0000 * / in.	CHECKED -	REVISED -
PLOT DATE = 2/22/2024	DATE - 2/22/2024	REVISED -

**STATE OF ILLINOIS
DEPARTMENT OF TRANSPORTATION**

STAGE 1 TRAFFIC CONTROL STANDARD 701321			
SCALE: 40,0000 ' / in.	SHEET 2	OF 2 SHEETS	STA. TO STA.

F.A.P. RTE.	SECTION	COUNTY	TOTAL SHEETS	SHEET NO.
823	(24BR-1)BR	WAYNE	57	15
			CONTRACT NO. 74857	
		ILLINOIS	FED. AID PROJECT	

LEGEND

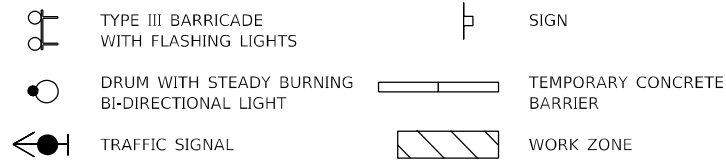

NOTES:

SUGGESTED SEQUENCE OF STAGE 2 OPERATIONS:
 1.RELOCATE TEMPORARY CONCRETE BARRIERS, IMPACT ATTENUATORS, AND TRAFFIC CONTROL DEVICES AS REQUIRED.
 2.CONSTRUCT THE STAGE 2 PORTION OF THE PROPOSED SUPERSTRUCTURE, BRIDGE APPROACH, PAVEMENT CONNECTOR, FURNISHED EXCAVATION, AND RIP RAP.
 3.CONSTRUCT GUARDRAIL ON THE SOUTH SIDE.
 4.REMOVE ALL TEMPORARY TRAFFIC BARRIERS AND CONTROL DEVICES.
 SEE TRAFFIC CONTROL AND PROTECTION STANDARD 701321 FOR INFORMATION NOT SHOWN ON THIS SHEET.

SECTION A-A

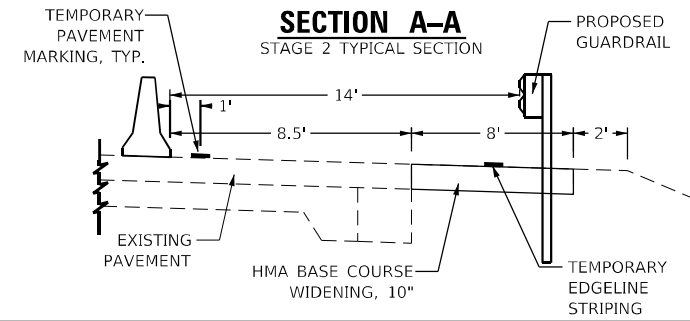

CONSTRUCT SIGNAGE AND DEVICES PER TRAFFIC CONTROL STANDARD 701321

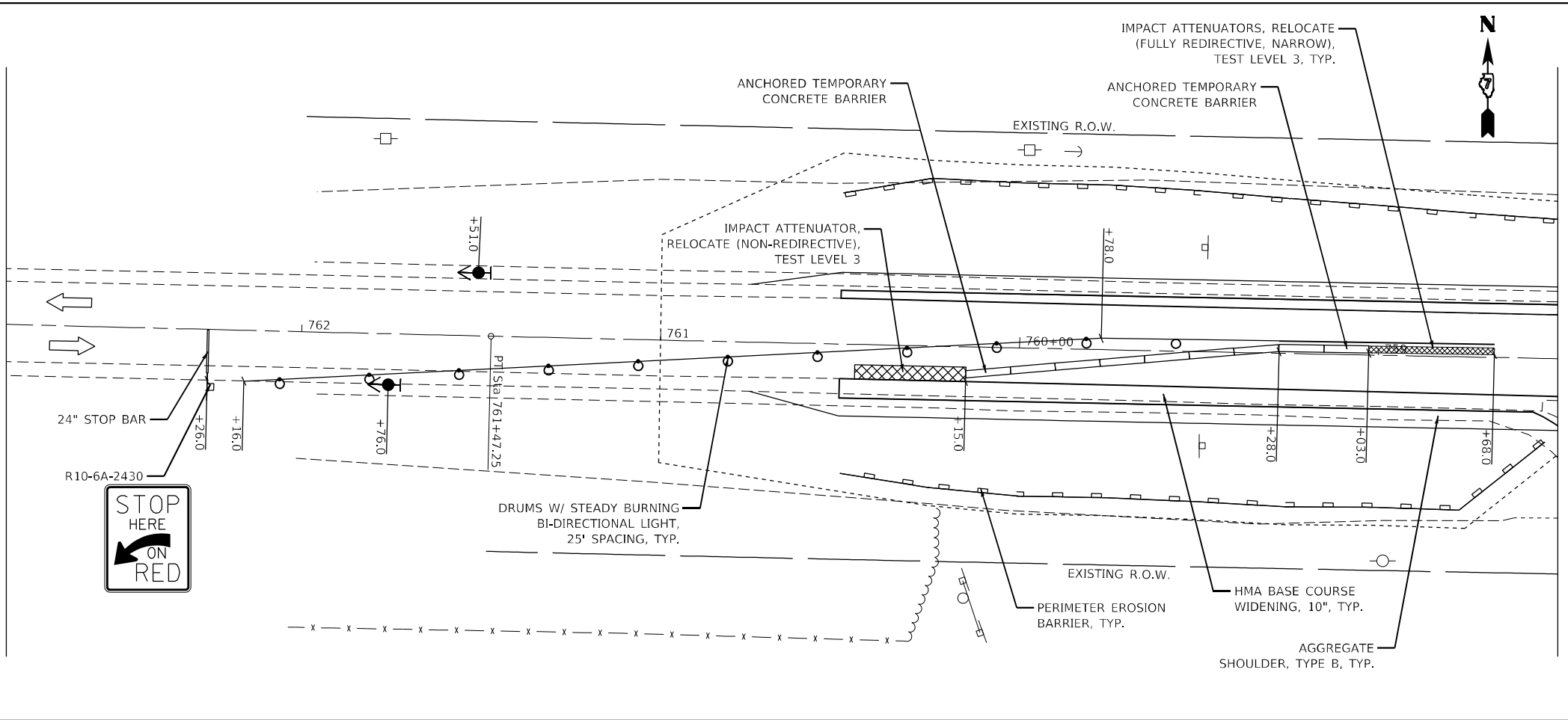

MATCHLINE STATION 758 + 50

MATCHLINE STATION 758 + 50

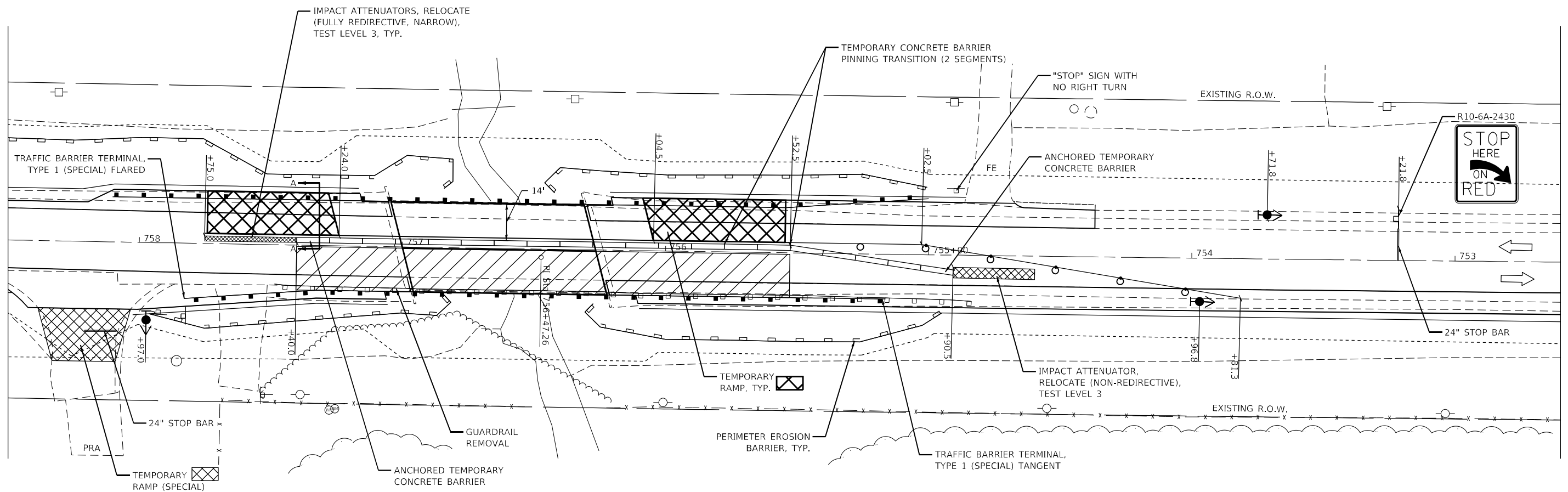

CONSTRUCT SIGNAGE AND DEVICES PER TRAFFIC CONTROL STANDARD 701321

MODEL: Default
FILE: Mainfile_psd\Subsect-pw-bead\paw.com\PIV\DOT\Documents\DOT Office\Director_7\Project\74857\CADD\Drawings\CD\Drawings\74857-18-1-24\stage2.dwg

USER NAME = Default	DESIGNED - LMH	REVISED -
	DRAWN - LMH	REVISED -
PLOT SCALE = 40,0000 ' / in.	CHECKED -	REVISED -
PLOT DATE = 2/22/2024	DATE - 2/22/2024	REVISED -

**STATE OF ILLINOIS
DEPARTMENT OF TRANSPORTATION**

**STAGE 2
TRAFFIC CONTROL STANDARD 701321**

SCALE: 40,0000 ' / in. SHEET 1 OF 1 SHEETS STA. TO STA.

F.A.P. RTE. 823	SECTION (24BR-1)BR	COUNTY WAYNE	TOTAL SHEETS 57	SHEET NO. 16
CONTRACT NO. 74857			ILLINOIS FED. AID PROJECT	

NOTES:

- SUGGESTED SEQUENCE OF POST-STAGE OPERATIONS:
 1. REMOVE ALL TEMPORARY TRAFFIC BARRIERS AND CONTROL DEVICES.
 2. SHIFT TRAFFIC AS NEEDED TO PERFORM MILLING, CONSTRUCT HMA BINDER AND SURFACE COURSE, AGGREGATE SHOULDERS, AND STRIPING.

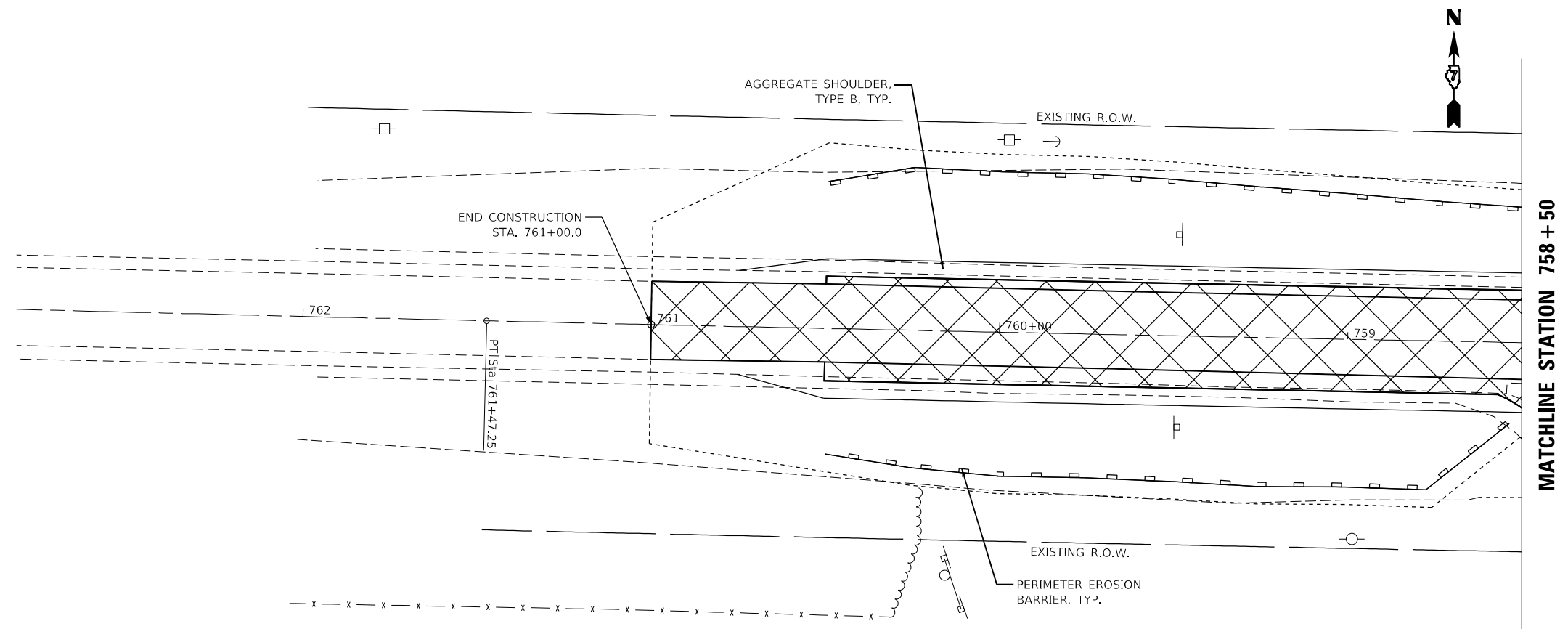
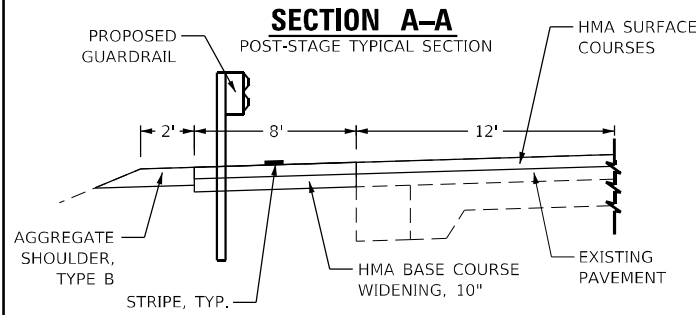

MATCHLINE STATION 758 + 50

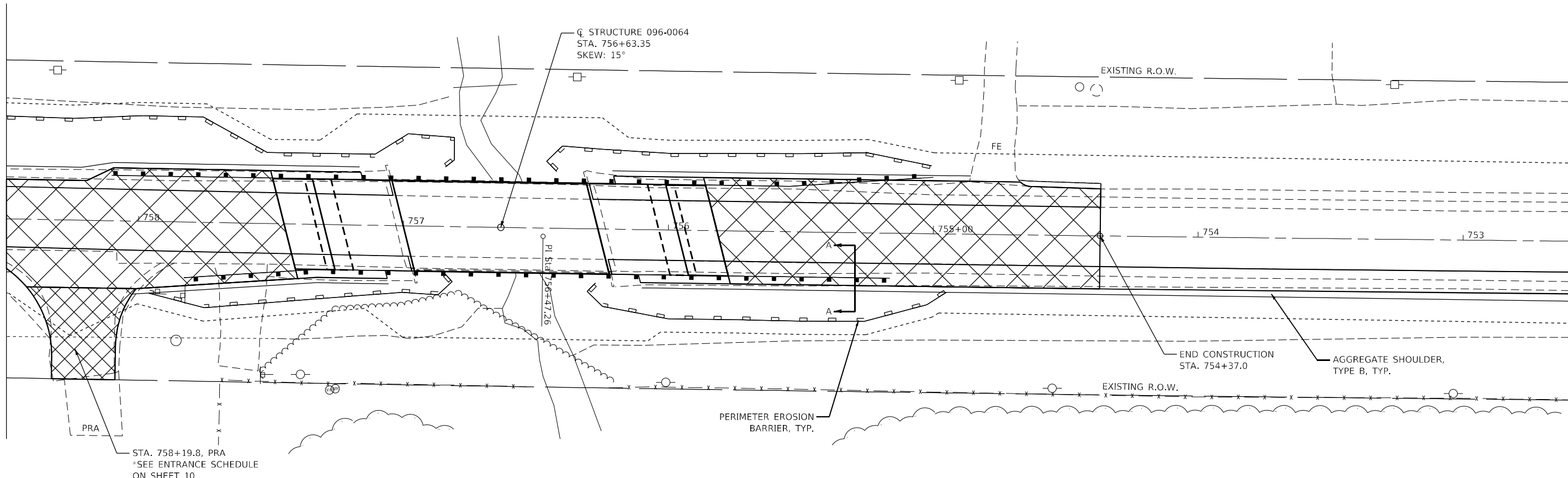

MATCHLINE STATION 758 + 50

MATCHLINE STATION 752 + 60

MODEL: Default
 FILE: Mainfile.pia
 SUBJECT: new bench.mxd
 PROJECT: 174857\Documents\DOT Office\Director_7\Project\174857\CADD\Drawings\CAD\Sheet\074857-PT-24810.dwg

USER NAME = Default	DESIGNED - LMH	REVISED -
PLOT SCALE = 40,0000 ' / in.	DRAWN - LMH	REVISED -
PLOT DATE = 2/22/2024	CHECKED -	REVISED -
	DATE - 2/22/2024	REVISED -

STATE OF ILLINOIS
DEPARTMENT OF TRANSPORTATION

POST-STAGE
 SCALE: 40,0000 ' / in. SHEET 1 OF 2 SHEETS STA. TO STA.

F.A.P. RTE.	SECTION	COUNTY	TOTAL SHEETS	SHEET NO.
823	(248R-1)BR	WAYNE	57	17
CONTRACT NO. 74857				
ILLINOIS FED. AID PROJECT				

NOTES:

SUGGESTED SEQUENCE OF POST-STAGE OPERATIONS:

1. REMOVE ALL TEMPORARY TRAFFIC BARRIERS AND CONTROL DEVICES.
2. SHIFT TRAFFIC AS NEEDED TO PERFORM MILLING, CONSTRUCT HMA BINDER AND SURFACE COURSE, AGGREGATE SHOULDERS, AND STRIPING.

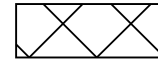

HMA SURFACE REMOVAL,
VARIABLE DEPTH AND
HMA SURFACE COURSES



MATCHLINE STATION 752 + 60

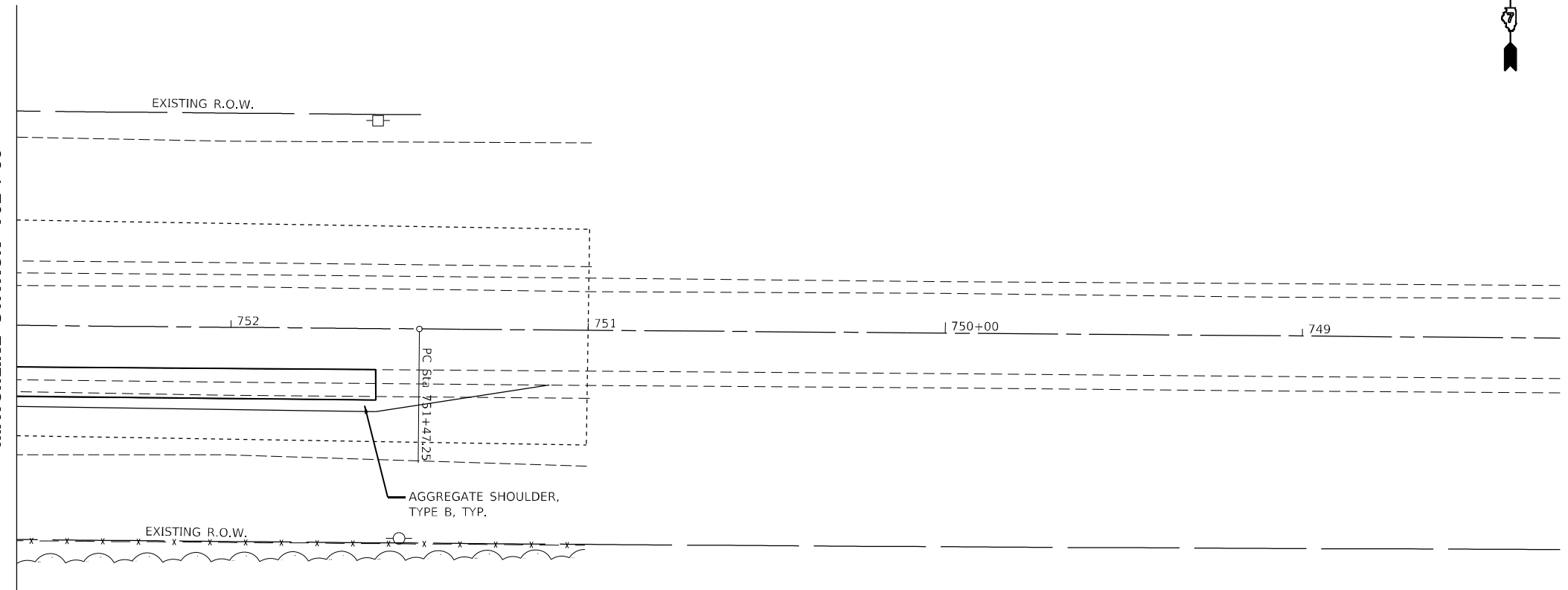

MODEL: Default
FILE: hma15.ctb
C:\Users\paw.bentley.com\PW\DOT\Documents\DOT Office\Director_7\Project\74857\CADD\Drawn\CAD\Sheets\74857-sh-staging.dgn

USER NAME = Default	DESIGNED - LMH	REVISED -
	DRAWN - LMH	REVISED -
PLOT SCALE = 40,0000 * / in.	CHECKED -	REVISED -
PLOT DATE = 2/22/2024	DATE - 2/22/2024	REVISED -

**STATE OF ILLINOIS
DEPARTMENT OF TRANSPORTATION**

POST-STAGE

SCALE: 40,0000 ' / in. SHEET 2 OF 2 SHEETS STA. TO STA.

F.A.P. RTE.	SECTION	COUNTY	TOTAL SHEETS	SHEET NO.
823	(24BR-1)BR	WAYNE	57	18
CONTRACT NO. 74857			ILLINOIS FED. AID PROJECT	

Benchmark WE4: Cut square on SE wingwall of SN 096-0064, Sta. 756+20, 18ft. LF of Centerline, Elev. 416.69.

Existing Structure: Structure 096-0064 was originally constructed in 1984 as part of F.A.P. Rte. 823, Section 24BR-1. The existing 2 span bridge consists of PPC deck beam superstructure supported on open pile bent abutments and a solid wall encased bent pier. The existing structure has a clear width of 32'-0" and out-to-out deck of 34'-0". The back-to-back abutment length is 75'-6". In 2003, the original bituminous wearing surface was removed and replaced with a 5" reinforced concrete overlay. The structure is on a 15°-0'-0" right forward skew. Traffic is to be maintained utilizing stage construction.

No salvage.

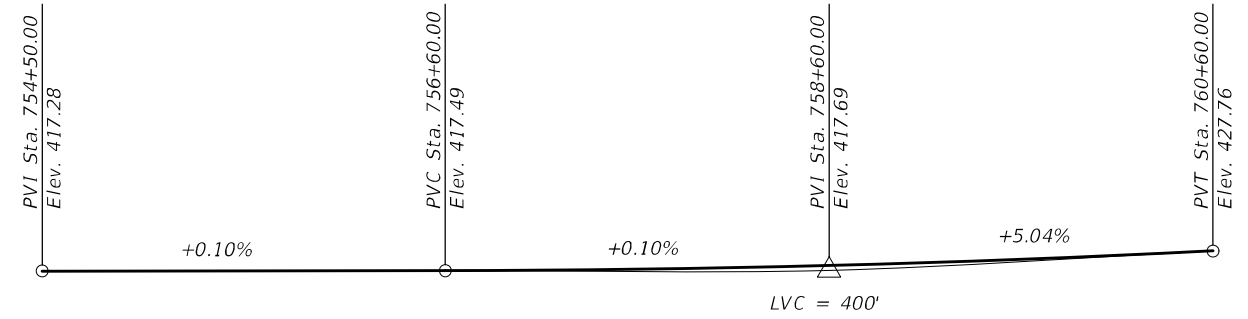
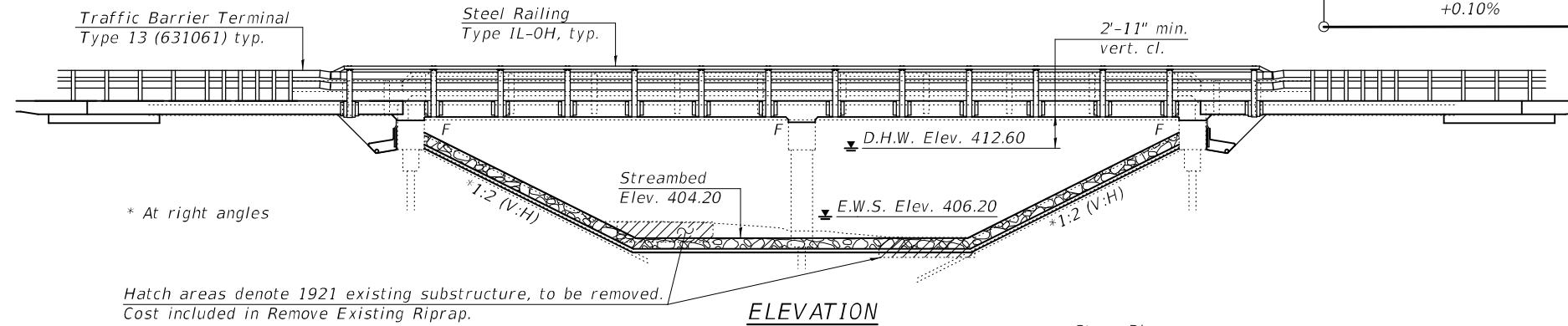

CURVE DATA

Existing Curve: C1
 P.I. Sta. = 756+47.26
 $\Delta = 0^\circ 52' 32''$ (RT)
 $D = 0^\circ 5' 15''$
 $R = 65,429.50'$
 $T = 500.01'$
 $L = 1,000.00'$
 $E = 1.91'$
 $e = N/A$
 $T.R. = N/A$
 $S.E. Run = N/A$
 P.C. Sta. = 751+47.25
 P.T. Sta. = 761+47.25

Due to the magnitude of the curve's radius, it was ignored in the preparation of these plans. All station, offset, and elevation values throughout are based upon the assumption that the roadway is on a tangent alignment.

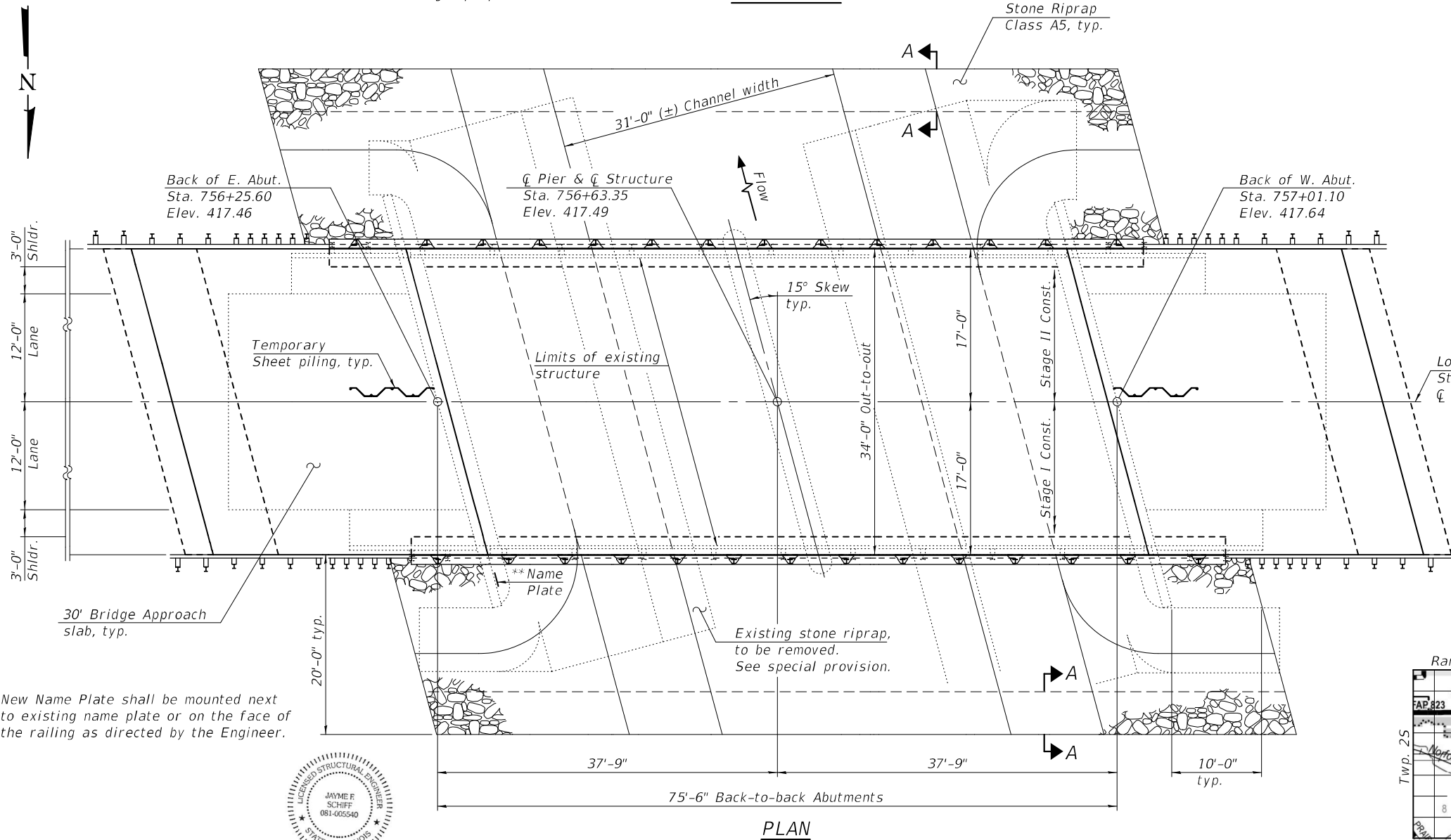

DESIGN SPECIFICATIONS

2020 AASHTO LRFD Bridge Design Specifications, 9th Edition

LOADING HL-93

Allow 50#/sq. ft. for future wearing surface.

DESIGN STRESSES

FIELD UNITS

$f'_c = 3,500$ psi (Appr. Slab Ftg.)
 $f'_c = 4,000$ psi (Superstructure)
 $f_y = 60,000$ psi (Reinforcement)

SEISMIC DATA

Seismic Performance Category (SPC) = B
 Bedrock Acceleration Coefficient (A) = 0.093g
 Site Coefficient (S) = 1.5

GENERAL PLAN & ELEVATION

ILLINOIS RTE 15 OVER

POND CREEK

F.A.P. ROUTE 823 - SEC (24BR-1)BR

WAYNE COUNTY

STA. 756+63.35

STRUCTURE NO. 096-0064

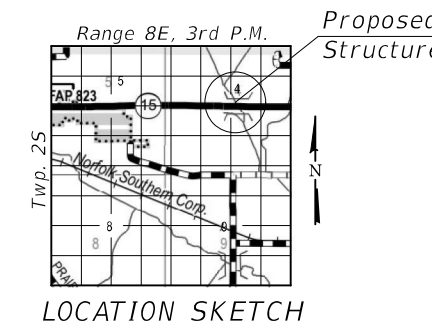

For Section A-A, see sheet 2 of 21.

EXPIRES 11-30-2024

DESIGNED -	ANDREW DIORIO
CHECKED -	PAUL JOHNSON
DRAWN -	ANDRO R. SAMANIEGO
CHECKED -	ANDREW DIORIO/PAUL JOHNSON

EXAMINED	<i>Mark Schuff</i> ENGINEER OF BRIDGE DESIGN	DATE -	3-27-2024
PASSED	<i>Jayme F. Schuff</i> ENGINEER OF BRIDGES AND STRUCTURES	REVISED -	
		REVISED -	

STATE OF ILLINOIS
DEPARTMENT OF TRANSPORTATION

SHEET 1 OF 21 SHEETS

F.A.P. RTE.	SECTION	COUNTY	TOTAL SHEETS	SHEET NO.
823	(24BR-1)BR	WAYNE	57	19
ILLINOIS FED. AID PROJECT			CONTRACT NO. 74857	

MODEL: 000000-00000-001
 FILE NAME: p:\w\p\w\benley.com\FWIDOT\Documents\IDOT Offices\Bureau of Bridges and Structures\Projects\0960064\CADD Plans\0960064-74857.dgn
 3/20/2024 1:14:17 PM

GENERAL NOTES

Reinforcement bars designated (E) shall be epoxy coated.
 Plan dimensions and details relative to existing plans are subject to nominal construction variations. The Contractor shall field verify existing dimensions and details affecting new construction and make necessary approved adjustments prior to construction or ordering of materials. Such variations shall not be cause for additional compensation for a change in scope of the work, however, the Contractor will be paid for the quantity actually furnished at the unit price bid for the work.
 The Contractor shall make allowance for the deflection of forms, shrinkage and settlement of falsework. Forms for deck slab shall be removed prior to placement of bridge approach slab.
 Layout of the slope protection system may be varied to suit ground conditions in the field as directed by the Engineer.

WATERWAY INFORMATION

Drainage Area = 3.2 sq. mi. Existing Overtopping Elevation = 416.4 at Sta. 748+50 Proposed Overtopping Elevation = 416.4 at Sta. 748+50										
Flood	Freq. Yr.	Q C.F.S.	Opening Ft ²		Nat. H.W.E.		Head - Ft.		Headwater El.	
			Exist.	Prop.	Exist.	Prop.	Exist.	Prop.	Exist.	Prop.
Design	50	2060	350	350	412.6	1.4	1.4	414.0	414.0	
Base	100	2410	360	360	412.8	1.6	1.6	414.4	414.4	
Scour Design Check	200	2800	380	380	413.0	2.9	2.9	415.9	415.9	
Max. Calc.	500	3310	390	390	413.2	2.9	2.9	416.1	416.1	

10 year velocity through existing bridge = 4.0 ft/s
 10 year velocity through proposed bridge = 4.0 ft/s

DESIGN SCOUR ELEVATION TABLE

Event / Limit State	Design Scour Elevations (ft.)			
	E. Abut.	Pier	W. Abut.	Item 113
Q100	412.7	395.6	412.7	5
Q200	412.7	389.5	412.7	
Design	412.7	395.6	412.7	
Check	412.7	389.5	412.7	

STATION 756+63.35
 RE-BUILT 20 BY
 STATE OF ILLINOIS
 F.A.P. RTE. 823 - SEC. (24BR-1)BR
 LOADING HL-93
 STRUCTURE NO. 096-0064

NAME PLATE
 See Std. 515001

INDEX OF SHEETS

- 1 - General Plan & Elevation
- 2 - General Data
- 3 - Stage Construction Details
- 4 - Temporary Sheet Piling
- 5 - Temporary Concrete Barrier for Stage Construction
- 6-7 - Top of Slab Elevations
- 8 - Top of East Approach Slab Elevations
- 9 - Top of West Approach Slab Elevations
- 10 - Superstructure Top Mat
- 11 - Superstructure Bottom Mat
- 12-13 - Superstructure Details
- 14-15 - Bridge Approach Slab Details
- 16-19 - Steel Railing Details, Type IL-0H
- 20 - Existing Abutment & Pier Details
- 21 - Bar Splicer Assembly and Mechanical Splicer Details

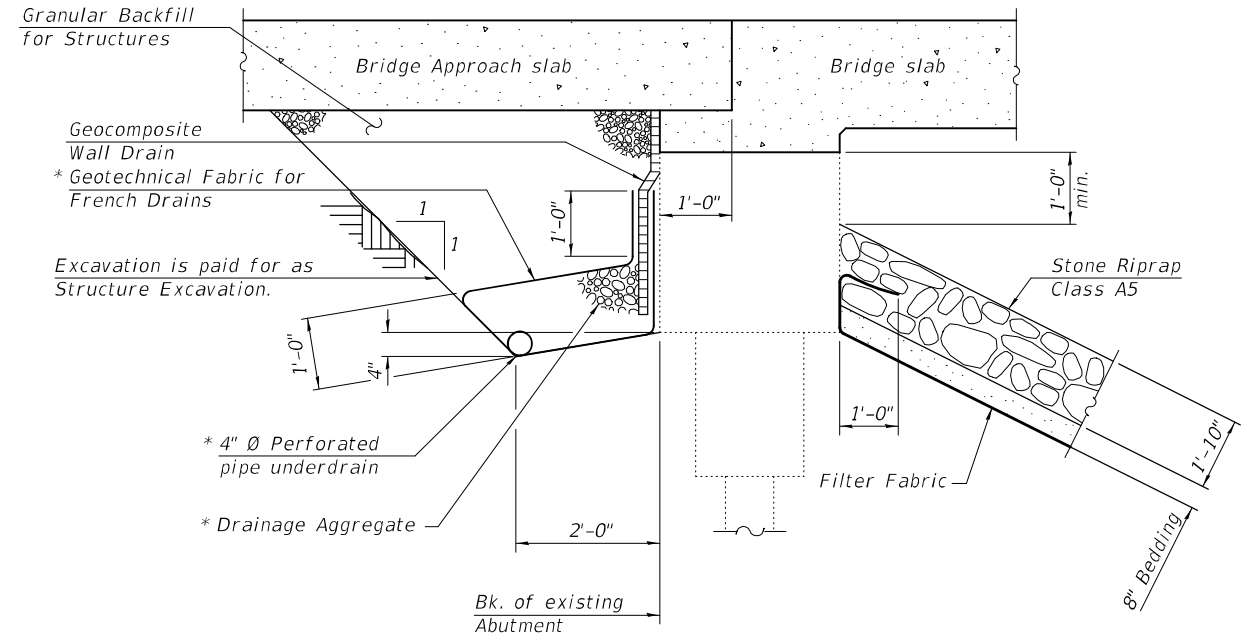

SECTION THRU ABUTMENT

(Horizontal dimensions are at right L's)

* Included in the cost of Pipe Underdrains for Structures.

Notes:

All drainage system components shall extend to 2'-0" from the end of each wingwall except an outlet pipe shall extend until intersecting with the side slopes. The pipes shall drain into concrete headwalls. (See Article 601.05 of the Standard Specifications and Highway Standard 601101.)

TOTAL BILL OF MATERIAL

ITEM	UNIT	SUPER	SUB	TOTAL
Removal of Existing Superstructures	Each	1	-	1
Stone Riprap, Class A5	Sq. Yd.	-	742	742
Filter Fabric	Sq. Yd.	-	742	742
Structure Excavation	Cu. Yd.	-	64	64
Protective Coat	Sq. Yd.	504	-	504
Concrete Structures	Cu. Yd.	-	21.7	21.7
Concrete Superstructure	Cu. Yd.	143.6	-	143.6
Bridge Deck Grooving	Sq. Yd.	474	-	474
Concrete Superstructure (Approach Slab)	Cu. Yd.	95.4	-	95.4
Reinforcement Bars, Epoxy Coated	Pound	80,050	4,610	84,660
Bar Splicers	Each	426	80	506
Temporary Sheet Piling	Sq. Ft.	-	175	175
Name Plates	Each	-	1	1
Steel Railing, Type IL-0H	Foot	199	-	199
Geocomposite Wall Drain	Sq. Yd.	-	33	33
Granular Backfill for Structures	Cu. Yd.	-	37	37
Pipe Underdrains for Structures 4"	Foot	-	107	107
Remove Existing Riprap	Cu. Yd.	-	121	121

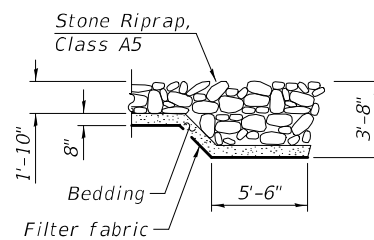

SECTION A-A

MODEL: 000000-00000-002
 FILE NAME: p:\w\l\p\w\benley.com\FWIDOT\Documents\DOT Offices\Bureau of Bridges and Structures\Projects\0960064\CADD Plans\0960064-74857.dgn

DESIGNED - ANDREW DIORIO	EXAMINED -
CHECKED - PAUL JOHNSON	PASSED -
DRAWN - ANDRO R. SAMANIEGO	
CHECKED - A.M.D. / P.S.J.	

DATE - MARCH 27, 2024
 ENGINEER OF BRIDGE DESIGN
 ENGINEER OF BRIDGES AND STRUCTURES

REVISD -
REVISD -

**STATE OF ILLINOIS
 DEPARTMENT OF TRANSPORTATION**

**GENERAL DATA
 STRUCTURE NO. 096-0064**

SHEET 2 OF 21 SHEETS

F.A.P. RTE. 823	SECTION (24BR-1)BR	COUNTY WAYNE	TOTAL SHEETS 57	SHEET NO. 20
ILLINOIS FED. AID PROJECT			CONTRACT NO. 74857	

MODEL: 000000-00000-003
 FILE NAME: p:\w\idol-pw\benley.com\FW\DOT\Documents\DOT Offices\Bureau of Bridges and Structures\Projects\0960064\CADD Plans\0960064-74857.dgn

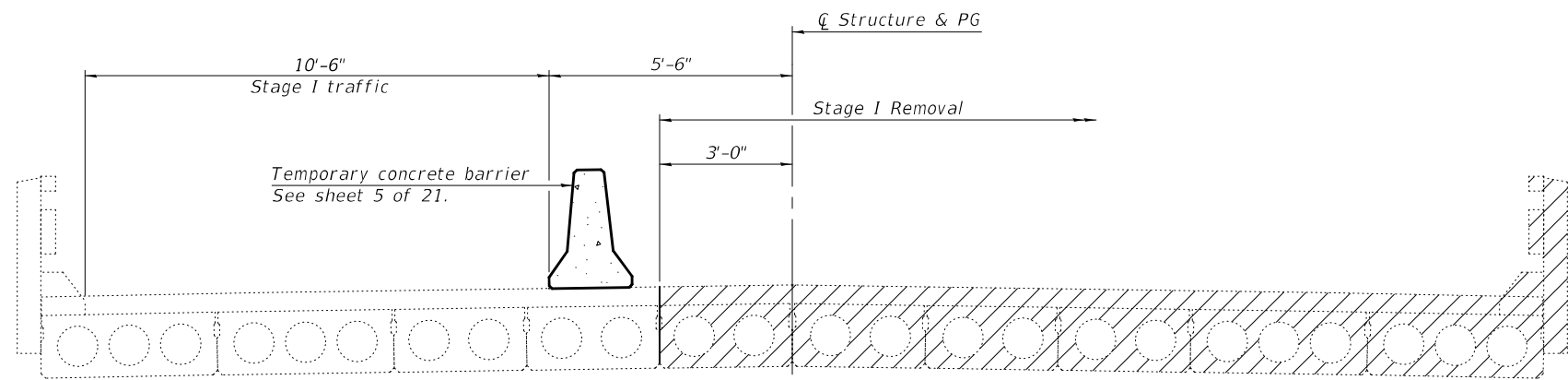

STAGE I REMOVAL

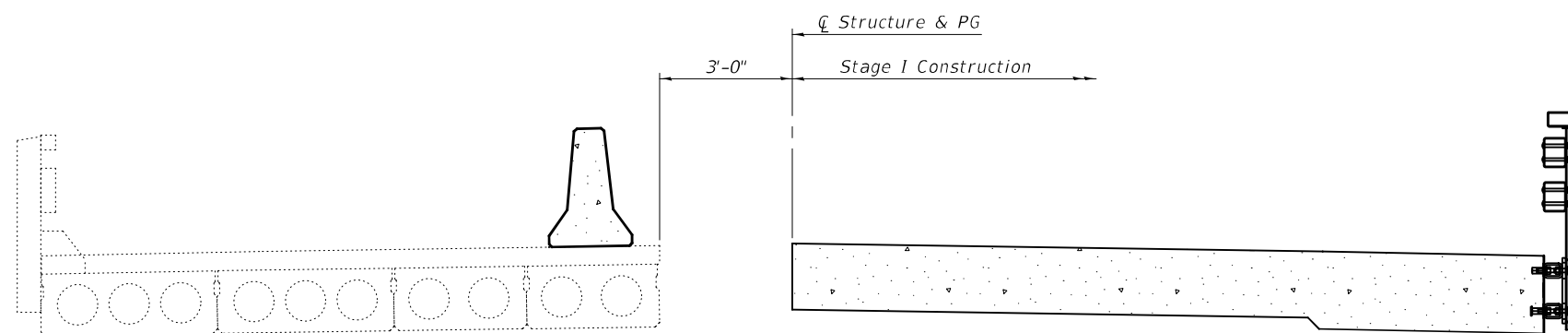

STAGE I CONSTRUCTION

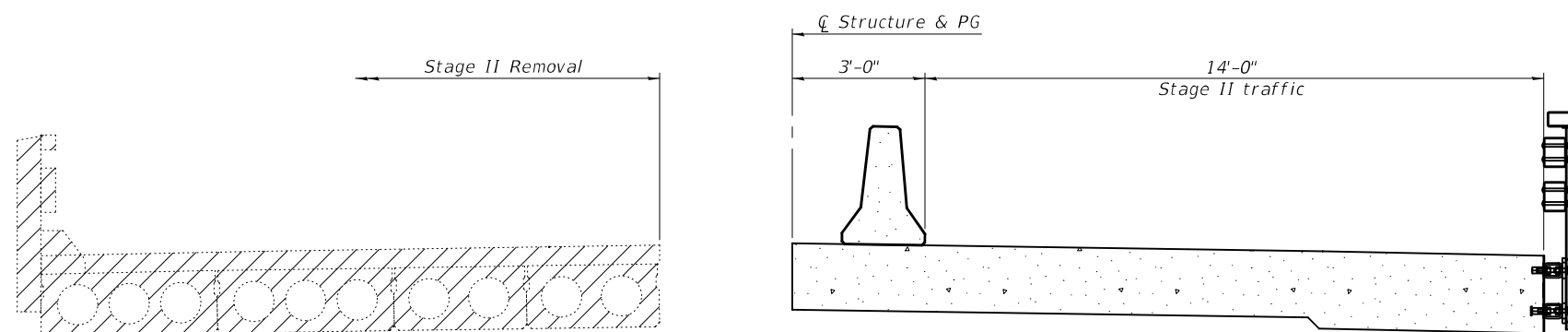

STAGE II REMOVAL

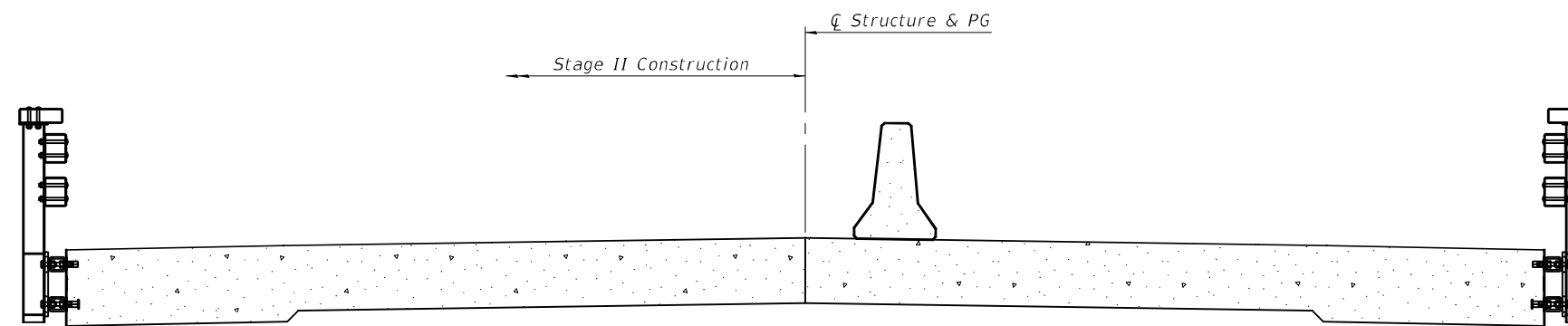

STAGE II CONSTRUCTION

Notes:
 All cross sections are looking West.
 Hatched area indicates Removal of Existing Superstructure.
 For quantity of Temporary Concrete Barrier, see Roadway Plans.

DESIGNED -	ANDREW DIORIO
CHECKED -	PAUL JOHNSON
DRAWN -	ANDRO R. SAMANIEGO
CHECKED -	A.M.D. / P.S.J.

EXAMINED	<i>Mark Shuffler</i> ENGINEER OF BRIDGE DESIGN
PASSED	<i>Jayne F. [Signature]</i> ENGINEER OF BRIDGES AND STRUCTURES

DATE -	MARCH 27, 2024
REVISED -	
REVISED -	

**STATE OF ILLINOIS
 DEPARTMENT OF TRANSPORTATION**

**STAGE CONSTRUCTION DETAILS
 STRUCTURE NO. 096-0064**

SHEET 3 OF 21 SHEETS

F.A.P. RTE.	SECTION	COUNTY	TOTAL SHEETS	SHEET NO.
823	(24BR-1)BR	WAYNE	57	21
CONTRACT NO. 74857				
ILLINOIS FED. AID PROJECT				

MODEL: 000000-00000-004
 FILE NAME: p:\w\p\w\benley.com\FWIDOT\Documents\DOT Offices\Bureau of Bridges and Structures\Projects\0960064\CADD Plans\0960064-74857.dgn

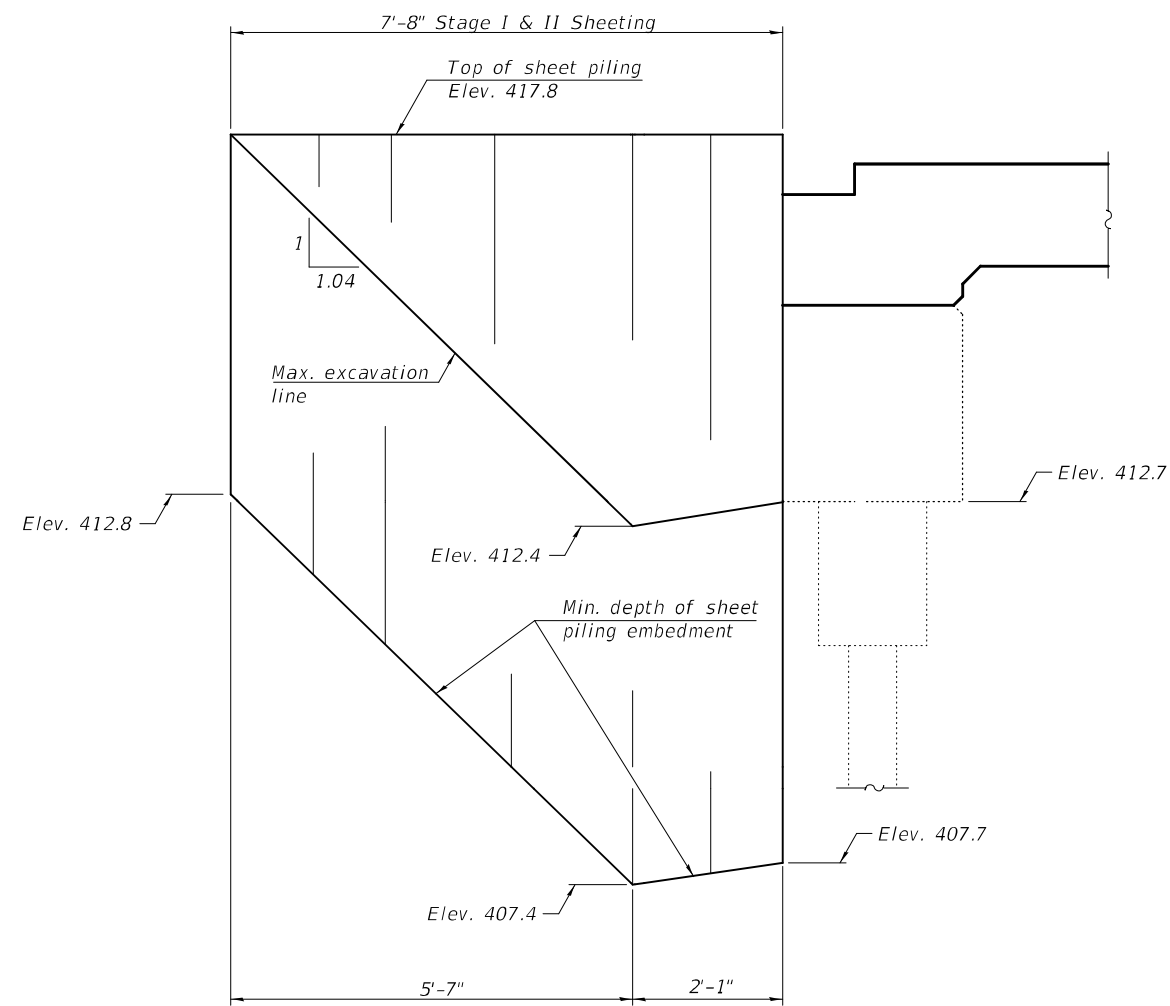

**EAST ABUTMENT
 TEMPORARY SHEET PILING**
 Section Modulus = 3.8 in³/ft

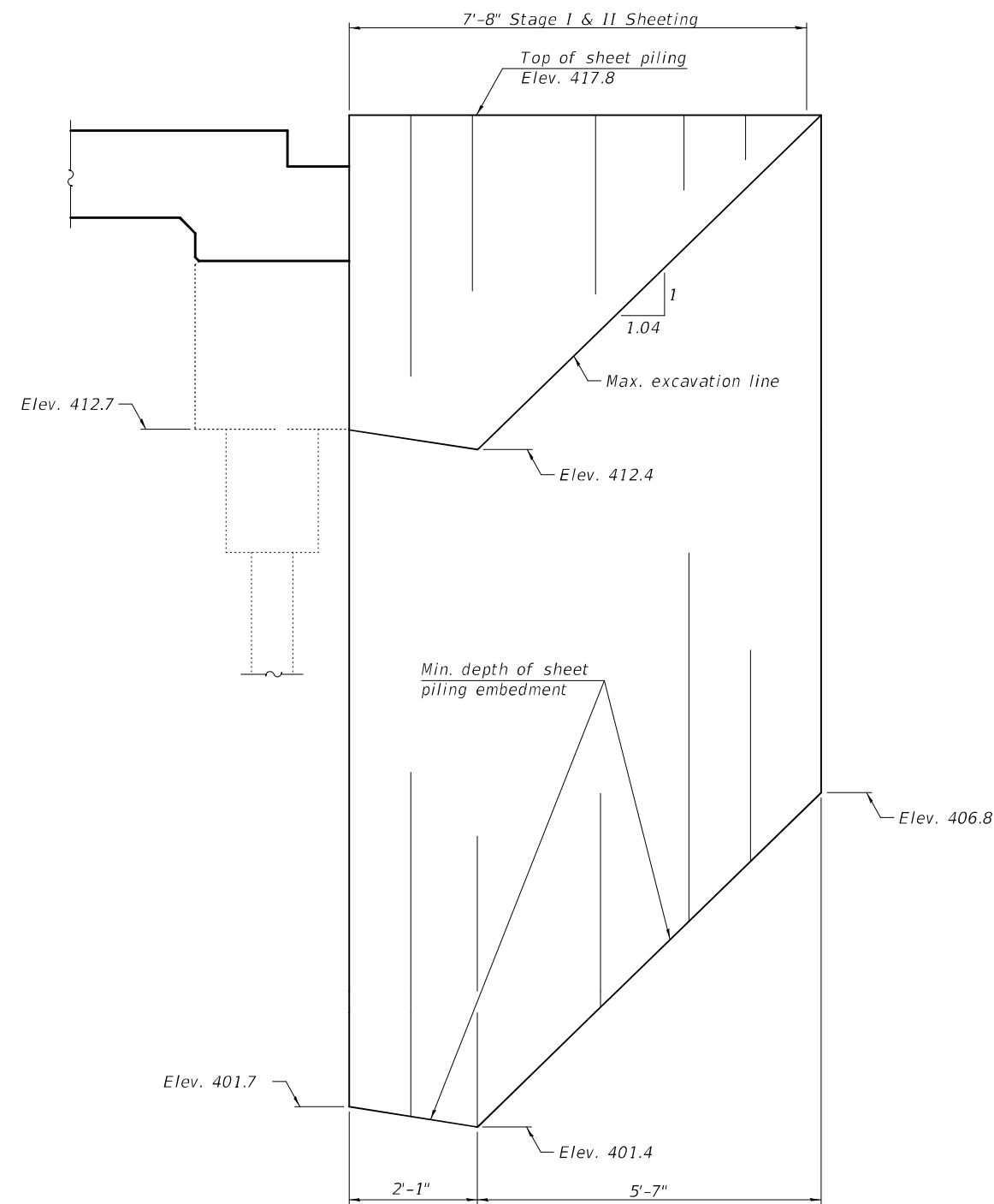

**WEST ABUTMENT
 TEMPORARY SHEET PILING**
 Section Modulus = 3.8 in³/ft

Note:
 If the Contractor chooses to alter the temporary cantilevered sheet piling design requirements as shown, a design submittal including plan details and calculations will be required for review and acceptance by the Engineer.

DESIGNED -	ANDREW DIORIO
CHECKED -	PAUL JOHNSON
DRAWN -	ANDRO R. SAMANIEGO
CHECKED -	A.M.D. / P.S.J.

EXAMINED	<i>Mark Shuffin</i> ENGINEER OF BRIDGE DESIGN
PASSED	<i>Jayne F. [Signature]</i> ENGINEER OF BRIDGES AND STRUCTURES

DATE -	MARCH 27, 2024
REVISED -	
REVISED -	

**STATE OF ILLINOIS
 DEPARTMENT OF TRANSPORTATION**

**TEMPORARY SHEET PILING
 STRUCTURE NO. 096-0064**

SHEET 4 OF 21 SHEETS

F.A.P. RTE.	SECTION	COUNTY	TOTAL SHEETS	SHEET NO.
823	(24BR-1)BR	WAYNE	57	22
CONTRACT NO. 74857				
ILLINOIS FED. AID PROJECT				

3/28/2024 9:28:15 AM

MODEL: 000000-00000-005
 FILE NAME: p:\w\p-w-bentley.com\FWIDOT\Documents\DOT Offices\Bureau of Bridges and Structures\Projects\0960064\CADD Plans\0960064-74857.dgn

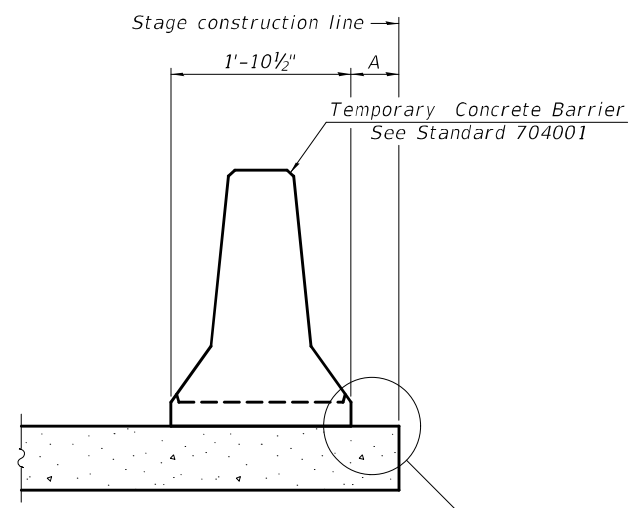

When "A" is 3'-1" or less, the temporary concrete barrier shall be restrained to the new slab according to Detail I, II or III. No restraint is required when "A" is greater than 3'-1".

NEW SLAB OR NEW DECK BEAM

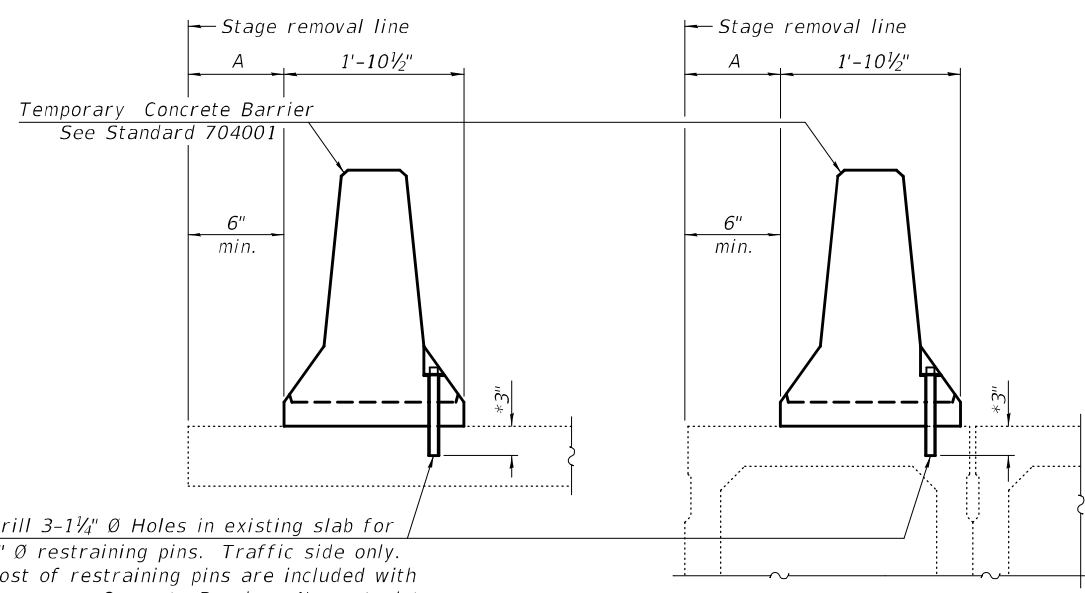

Drill 3-1/4" Ø Holes in existing slab for 1" Ø restraining pins. Traffic side only. Cost of restraining pins are included with Temporary Concrete Barrier. No restraint is required when "A" is greater than 3'-1".

EXISTING SLAB

* When hot-mix asphalt wearing surface is present, embedment shall be 3" plus the wearing surface depth.

EXISTING DECK BEAM

SECTIONS THRU SLAB OR DECK BEAM

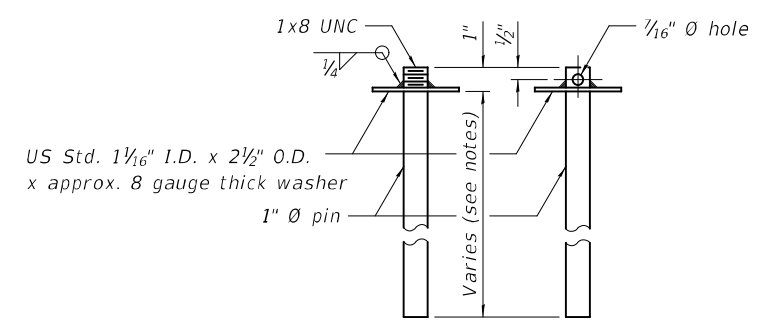

RESTRAINING PIN

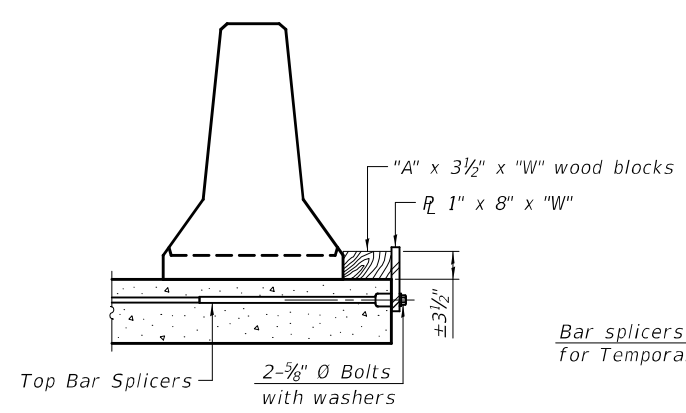

DETAIL I

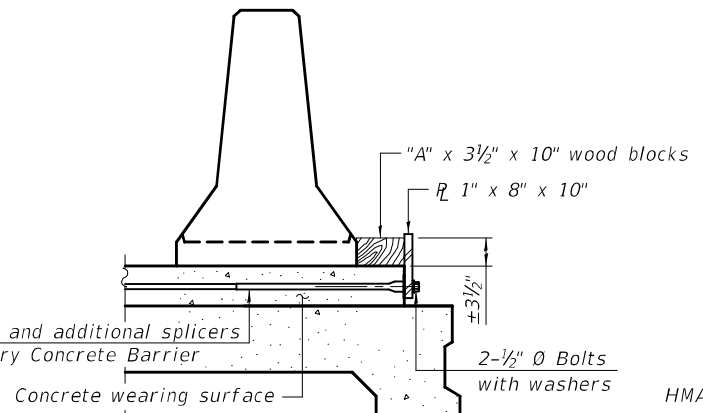

DETAIL II

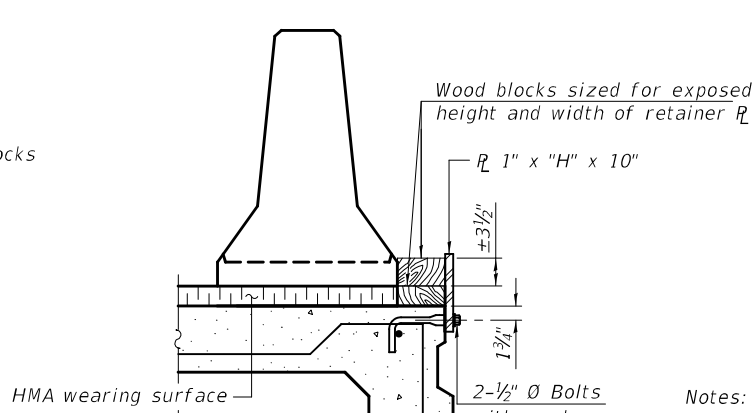

DETAIL III

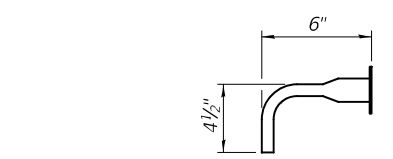

BAR SPLICER FOR #4 BAR - DETAIL III

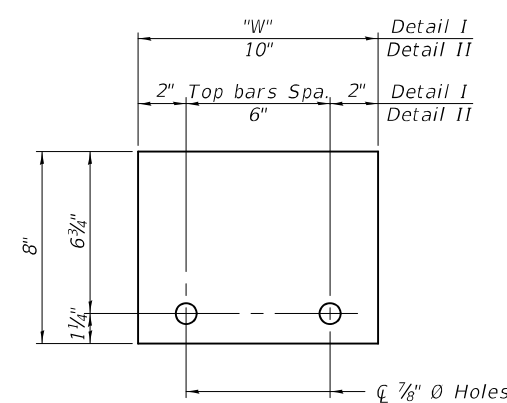

STEEL RETAINER R 1" x 8" x "W"
(Detail I and II)

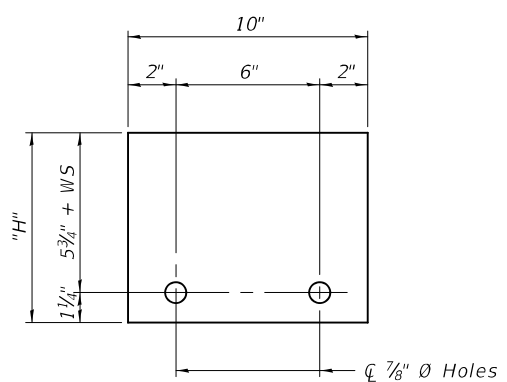

STEEL RETAINER R 1" x "H" x 10"
(Detail III)

Notes:
 Cost of retainer assembly is included with Temporary Concrete Barrier.
 A retainer assembly shall be located at the approximate center of each temporary concrete barrier.
 The retainer plate shall not be removed until the concrete on the adjacent stage is ready to be poured. For Detail III applications the retainer plate shall not be removed until just prior to placing the adjacent beam.
 When the 'A' dimension is less than 1 1/2', the wood block shall be omitted and the barrier shall be placed in direct contact with the steel retainer plate. For deck beam applications the minimum required 'A' distance is 6' to accommodate the shear key clamping device.
Detail I - Installation for a new bridge deck or bridge slab.
Detail II - Installation for a new deck beam with an initial concrete wearing surface. Additional bar splicers shall be provided at 6'-0" centers and paired with the bar splicers of the concrete wearing surface reinforcement to accommodate the installation of the retainer assemblies. The cost of the additional bar splicers is included with the concrete wearing surface.
Detail III - Installation for a new deck beam with no initial wearing surface or with an initial hot-mix asphalt (HMA) wearing surface present. The deck beam directly beneath the temporary concrete barrier shall be fabricated with bar splicer inserts in the side of the beam, as detailed, to accommodate the installation of the retainer assemblies. A pair of bar splicers, 6" apart, shall be placed at 6'-0" centers along the length of the beam. The cost of the bar splicers is included with the deck beam.

RAILING CRITERIA

NCHRP 350 Test Level	3
Railing Weight (plf)	440

R-27 10-12-2021

DESIGNED - ANDREW DIORIO	EXAMINED
CHECKED - PAUL JOHNSON	PASSED
DRAWN - ANDRO R. SAMANIEGO	
CHECKED - A.M.D. / P.S.J.	

DATE - MARCH 27, 2024

REVISOR -

REVISOR -

STATE OF ILLINOIS
DEPARTMENT OF TRANSPORTATION

TEMPORARY CONCRETE BARRIER
STRUCTURE NO. 096-0064

SHEET 5 OF 21 SHEETS

F.A.P. RTE.	SECTION	COUNTY	TOTAL SHEETS	SHEET NO.
823	(24BR-1)BR	WAYNE	57	23
CONTRACT NO. 74857				

ILLINOIS FED. AID PROJECT

3/28/2024 9:28:15 AM

MODEL: 000000-00000-006
 FILE NAME: p:\w\p\w\benley.com\FWIDOT\Documents\DOT Offices\Bureau of Bridges and Structures\Projects\0960064\CADD Plans\0960064-74857.dgn

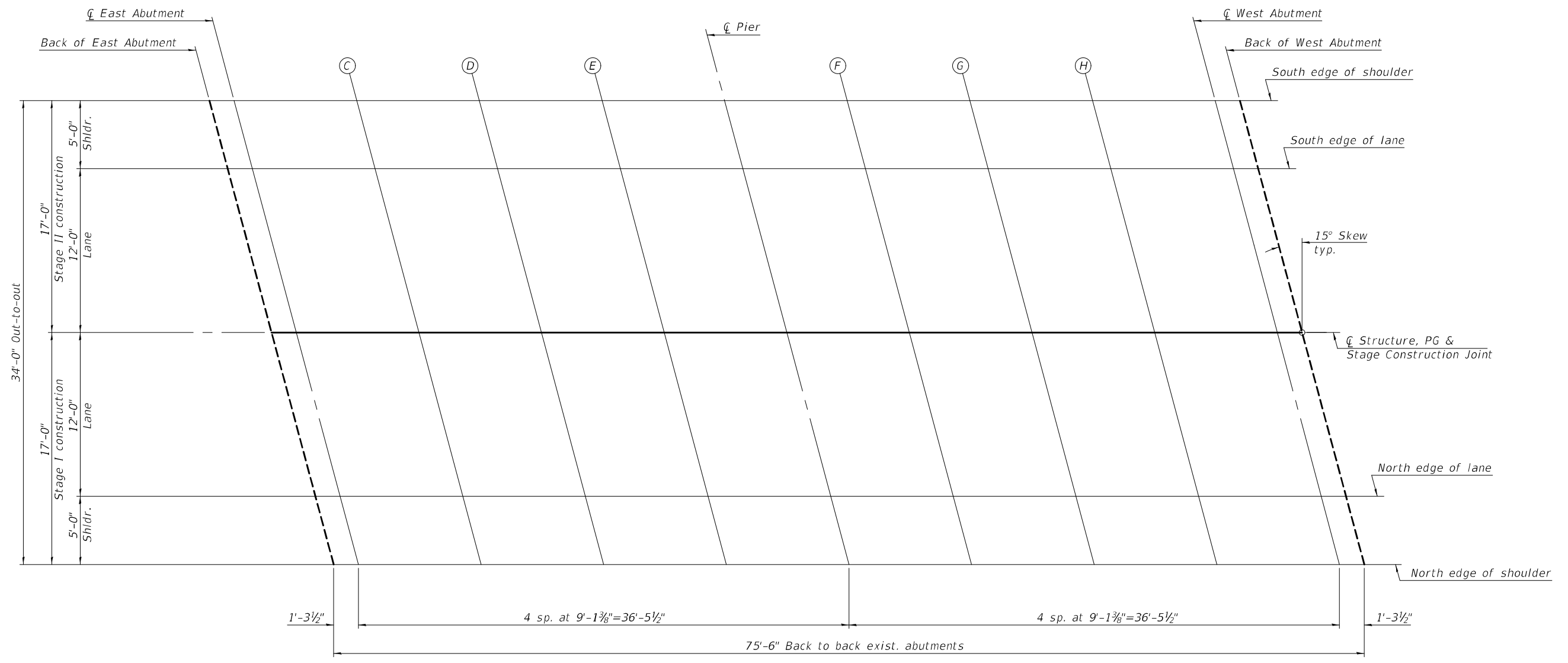

PLAN

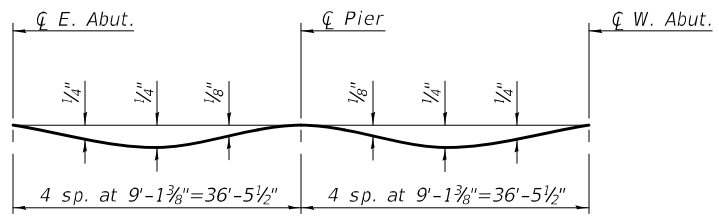

DEAD LOAD DEFLECTION DIAGRAM

(Includes weight of concrete only.)

Note:
 The above deflections are not to be used in the field if the engineer is working from the grade elevations adjusted for dead load deflections as shown on sheet 7 of 21.

DESIGNED -	ANDREW DIORIO
CHECKED -	PAUL JOHNSON
DRAWN -	ANDRO R. SAMANIEGO
CHECKED -	A.M.D. / P.S.J.

EXAMINED	<i>Mark Shuffler</i> ENGINEER OF BRIDGE DESIGN
PASSED	<i>Jayne F. [Signature]</i> ENGINEER OF BRIDGES AND STRUCTURES

DATE -	MARCH 27, 2024
REVISED -	
REVISED -	

STATE OF ILLINOIS
DEPARTMENT OF TRANSPORTATION

TOP OF SLAB ELEVATIONS
STRUCTURE NO. 096-0064

SHEET 6 OF 21 SHEETS

F.A.P. RTE.	SECTION	COUNTY	TOTAL SHEETS	SHEET NO.
823	(24BR-1)BR	WAYNE	57	24
ILLINOIS FED. AID PROJECT			CONTRACT NO. 74857	

SOUTH EDGE OF SHOULDER

Location	Station	Offset	Theoretical Grade Elevations	Theoretical Grade Elevations Adjusted for Dead Load Deflection
Bk. East Abutment	756+21.04	-17.00	417.17	417.17
└─┬ East Abutment	756+22.34	-17.00	417.17	417.17
C	756+31.45	-17.00	417.18	417.20
D	756+40.57	-17.00	417.19	417.21
E	756+49.68	-17.00	417.20	417.21
└─┬ Pier	756+58.79	-17.00	417.21	417.21
F	756+67.91	-17.00	417.22	417.23
G	756+77.02	-17.00	417.24	417.26
H	756+86.14	-17.00	417.28	417.30
└─┬ West Abutment	756+95.25	-17.00	417.32	417.32
Bk. West Abutment	756+96.54	-17.00	417.33	417.33

SOUTH EDGE OF LANE

Location	Station	Offset	Theoretical Grade Elevations	Theoretical Grade Elevations Adjusted for Dead Load Deflection
Bk. East Abutment	756+22.38	-12.00	417.27	417.27
└─┬ East Abutment	756+23.68	-12.00	417.27	417.27
C	756+32.79	-12.00	417.28	417.30
D	756+41.91	-12.00	417.29	417.31
E	756+51.02	-12.00	417.30	417.31
└─┬ Pier	756+60.13	-12.00	417.31	417.31
F	756+69.25	-12.00	417.32	417.33
G	756+78.36	-12.00	417.35	417.37
H	756+87.48	-12.00	417.38	417.40
└─┬ West Abutment	756+96.59	-12.00	417.43	417.43
Bk. West Abutment	756+97.88	-12.00	417.44	417.44

└ STRUCTURE, PG, & STAGE CONSTRUCTION JOINT

Location	Station	Offset	Theoretical Grade Elevations	Theoretical Grade Elevations Adjusted for Dead Load Deflection
Bk. East Abutment	756+25.60	0.00	417.46	417.46
└─┬ East Abutment	756+26.89	0.00	417.46	417.46
C	756+36.01	0.00	417.47	417.49
D	756+45.12	0.00	417.48	417.50
E	756+54.24	0.00	417.48	417.49
└─┬ Pier	756+63.35	0.00	417.49	417.49
F	756+72.46	0.00	417.51	417.52
G	756+81.58	0.00	417.54	417.56
H	756+90.69	0.00	417.58	417.60
└─┬ West Abutment	756+99.81	0.00	417.63	417.63
Bk. West Abutment	757+01.10	0.00	417.64	417.64

NORTH EDGE OF LANE

Location	Station	Offset	Theoretical Grade Elevations	Theoretical Grade Elevations Adjusted for Dead Load Deflection
Bk. East Abutment	756+28.82	12.00	417.28	417.28
└─┬ East Abutment	756+30.11	12.00	417.28	417.28
C	756+39.22	12.00	417.29	417.31
D	756+48.34	12.00	417.30	417.32
E	756+57.45	12.00	417.31	417.32
└─┬ Pier	756+66.57	12.00	417.32	417.32
F	756+75.68	12.00	417.34	417.35
G	756+84.79	12.00	417.37	417.39
H	756+93.91	12.00	417.41	417.43
└─┬ West Abutment	757+03.02	12.00	417.47	417.47
Bk. West Abutment	757+04.32	12.00	417.48	417.48

NORTH EDGE OF SHOULDER

Location	Station	Offset	Theoretical Grade Elevations	Theoretical Grade Elevations Adjusted for Dead Load Deflection
Bk. East Abutment	756+30.16	17.00	417.18	417.18
└─┬ East Abutment	756+31.45	17.00	417.18	417.18
C	756+40.56	17.00	417.19	417.21
D	756+49.68	17.00	417.20	417.22
E	756+58.79	17.00	417.21	417.22
└─┬ Pier	756+67.91	17.00	417.22	417.22
F	756+77.02	17.00	417.24	417.25
G	756+86.13	17.00	417.28	417.30
H	756+95.25	17.00	417.32	417.34
└─┬ West Abutment	757+04.36	17.00	417.38	417.38
Bk. West Abutment	757+05.66	17.00	417.38	417.38

MODEL: 000000-00000-007
FILE NAME: p:\w\p\w\benley.com\FWIDOT\Documents\DOT Offices\Bureau of Bridges and Structures\Projects\0960064\CADD Plans\0960064-74857.dgn
3/28/2024 9:28:16 AM

DESIGNED -	ANDREW DIORIO
CHECKED -	PAUL JOHNSON
DRAWN -	ANDRO R. SAMANIEGO
CHECKED -	A.M.D. / P.S.J.

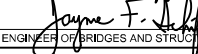
EXAMINED	 MARK SHUFFLER ENGINEER OF BRIDGE DESIGN	DATE -	MARCH 27, 2024
PASSED	 JAYME F. HOFF ENGINEER OF BRIDGES AND STRUCTURES	REVISED -	

REVISED -	
REVISED -	

**STATE OF ILLINOIS
DEPARTMENT OF TRANSPORTATION**

**TOP OF SLAB ELEVATIONS
STRUCTURE NO. 096-0064**

SHEET 7 OF 21 SHEETS

F.A.P. RTE.	SECTION	COUNTY	TOTAL SHEETS	SHEET NO.
823	(24BR-1)BR	WAYNE	57	25
			CONTRACT NO. 74857	
		ILLINOIS	FED. AID PROJECT	

SOUTH EDGE OF SHOULDER

Location	Station	Offset	Theoretical Grade Elevations
East end of E. Appr. slab	755+92.08	-17.00	417.14
A	756+02.08	-17.00	417.15
B	756+12.08	-17.00	417.16
West end of E. Appr. slab	756+22.08	-17.00	417.17

SOUTH EDGE OF LANE

Location	Station	Offset	Theoretical Grade Elevations
East end of E. Appr. slab	755+93.42	-12.00	417.24
A	756+03.42	-12.00	417.25
B	756+13.42	-12.00	417.26
West end of E. Appr. slab	756+23.42	-12.00	417.27

☉ STRUCTURE, PG & STAGE CONSTRUCTION JOINT

Location	Station	Offset	Theoretical Grade Elevations
East end of E. Appr. slab	755+96.63	0.00	417.43
A	756+06.63	0.00	417.44
B	756+16.63	0.00	417.45
West end of E. Appr. slab	756+26.63	0.00	417.46

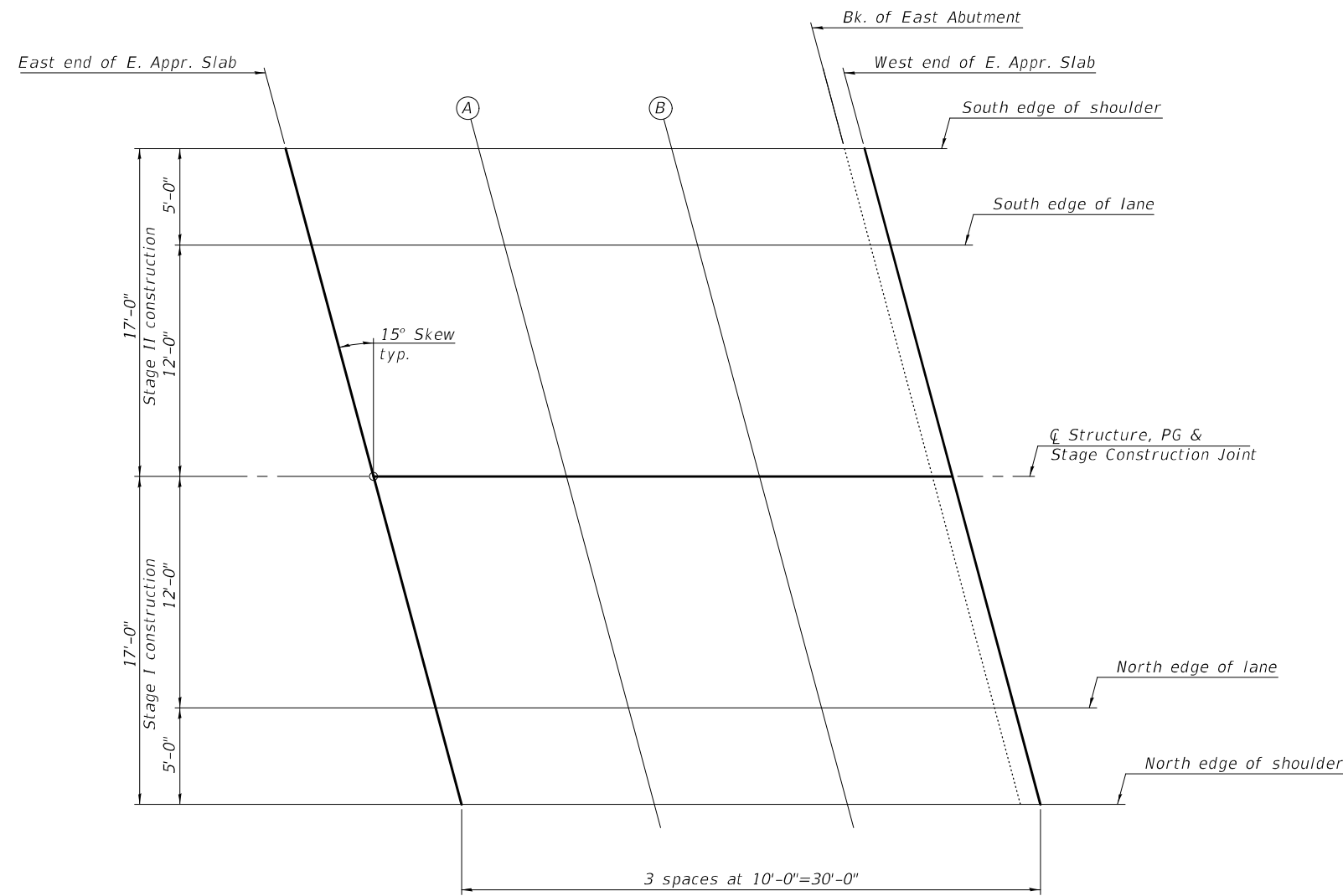

PLAN

NORTH EDGE OF LANE

Location	Station	Offset	Theoretical Grade Elevations
East end of E. Appr. slab	755+99.85	12.00	417.25
A	756+09.85	12.00	417.26
B	756+19.85	12.00	417.27
West end of E. Appr. slab	756+29.85	12.00	417.28

NORTH EDGE OF SHOULDER

Location	Station	Offset	Theoretical Grade Elevations
East end of E. Appr. slab	756+01.19	17.00	417.15
A	756+11.19	17.00	417.16
B	756+21.19	17.00	417.17
West end of E. Appr. slab	756+31.19	17.00	417.18

MODEL: 0000000-00000-008
FILE NAME: p:\w\p\w\benley.com\FWIDOT\Documents\DOT Offices\Bureau of Bridges and Structures\Projects\0960064\CADD Plans\0960064-74857.dgn
3/28/2024 9:28:16 AM

DESIGNED -	ANDREW DIORIO
CHECKED -	PAUL JOHNSON
DRAWN -	ANDRO R. SAMANIEGO
CHECKED -	A.M.D./P.S.J.

EXAMINED		DATE -	MARCH 27, 2024
PASSED		REVISED -	
	ENGINEER OF BRIDGES AND STRUCTURES	REVISED -	

**STATE OF ILLINOIS
DEPARTMENT OF TRANSPORTATION**

**TOP OF EAST APPROACH SLAB ELEVATIONS
STRUCTURE NO. 096-0064**

F.A.P. RTE.	SECTION	COUNTY	TOTAL SHEETS	SHEET NO.
823	(24BR-1)BR	WAYNE	57	26
			CONTRACT NO. 74857	
		ILLINOIS	FED. AID PROJECT	

SOUTH EDGE OF SHOULDER

Location	Station	Offset	Theoretical Grade Elevations
East end of W. Appr. slab	756+95.51	-17.00	417.32
I	757+05.51	-17.00	417.38
J	757+15.51	-17.00	417.46
West end of W. Appr. slab	757+25.51	-17.00	417.54

SOUTH EDGE OF LANE

Location	Station	Offset	Theoretical Grade Elevations
East end of W. Appr. slab	756+96.85	-12.00	417.43
I	757+06.85	-12.00	417.49
J	757+16.85	-12.00	417.57
West end of W. Appr. slab	757+26.85	-12.00	417.65

☉ STRUCTURE, PG & STAGE CONSTRUCTION JOINT

Location	Station	Offset	Theoretical Grade Elevations
East end of W. Appr. slab	757+00.06	0.00	417.63
I	757+10.06	0.00	417.69
J	757+20.06	0.00	417.77
West end of W. Appr. slab	757+30.06	0.00	417.86

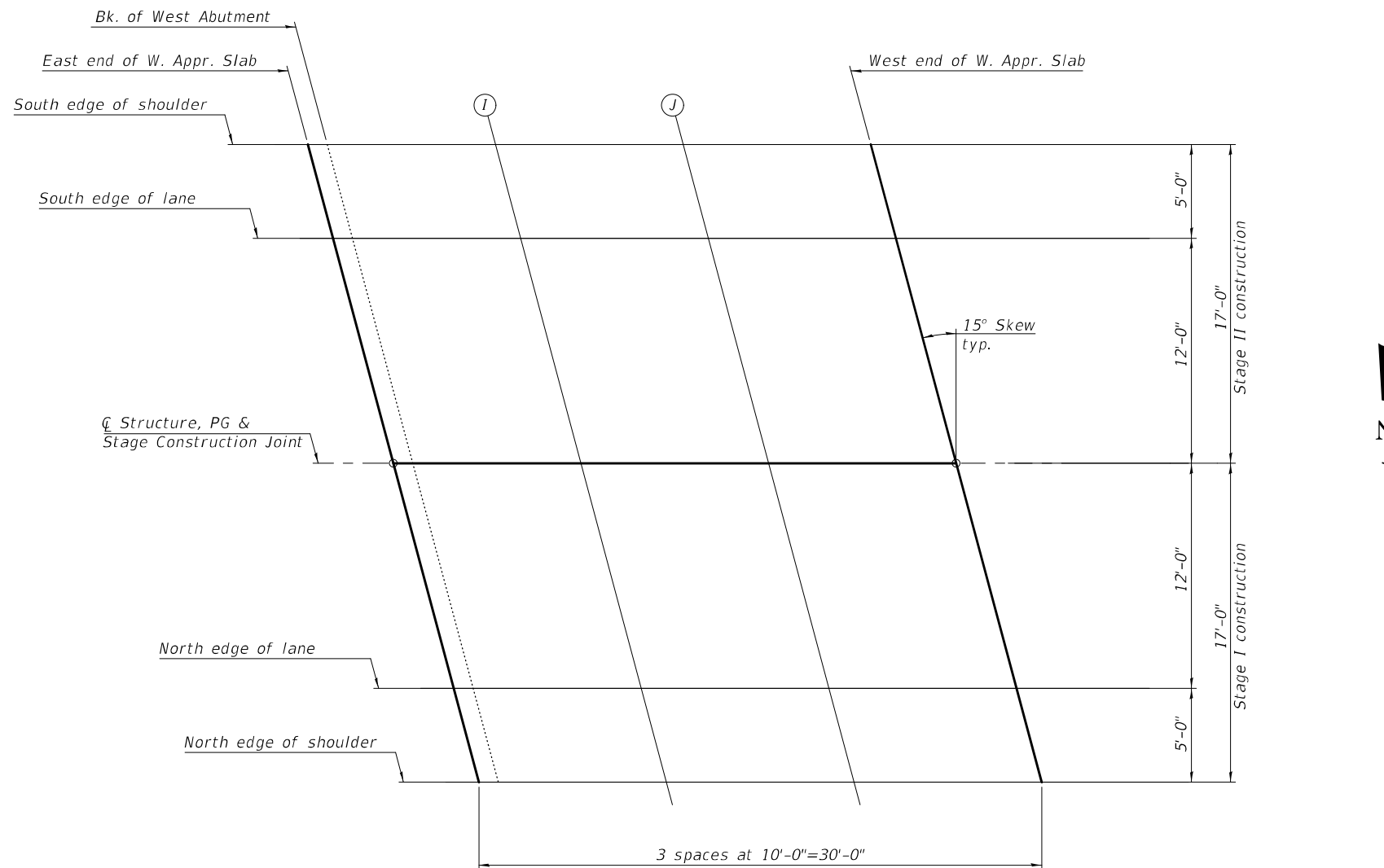

NORTH EDGE OF LANE

Location	Station	Offset	Theoretical Grade Elevations
East end of W. Appr. slab	757+03.28	12.00	417.47
I	757+13.28	12.00	417.54
J	757+23.28	12.00	417.62
West end of W. Appr. slab	757+33.28	12.00	417.71

NORTH EDGE OF SHOULDER

Location	Station	Offset	Theoretical Grade Elevations
East end of W. Appr. slab	757+04.62	17.00	417.38
I	757+14.62	17.00	417.45
J	757+24.62	17.00	417.53
West end of W. Appr. slab	757+34.62	17.00	417.63

MODEL: 000000-00000-009
 FILE NAME: p:\w\p\w\benley.com\FWIDOT\Documents\DOT Offices\Bureau of Bridges and Structures\Projects\0960064\CADD Plans\0960064-74857.dgn
 3/28/2024 9:28:16 AM

DESIGNED - ANDREW DIORIO	EXAMINED - <i>Mark Shuffler</i>	DATE - MARCH 27, 2024
CHECKED - PAUL JOHNSON	PASSED - <i>Jaime F. [Signature]</i>	REVISOR -
DRAWN - ANDRO R. SAMANIEGO	ENGINEER OF BRIDGES AND STRUCTURES	REVISOR -
CHECKED - A.M.D./P.S.J.		

STATE OF ILLINOIS
 DEPARTMENT OF TRANSPORTATION

TOP OF WEST APPROACH SLAB ELEVATIONS
 STRUCTURE NO. 096-0064

F.A.P. RTE. 823	SECTION (24BR-1)BR	COUNTY WAYNE	TOTAL SHEETS 57	SHEET NO. 27
CONTRACT NO. 74857			ILLINOIS FED. AID PROJECT	

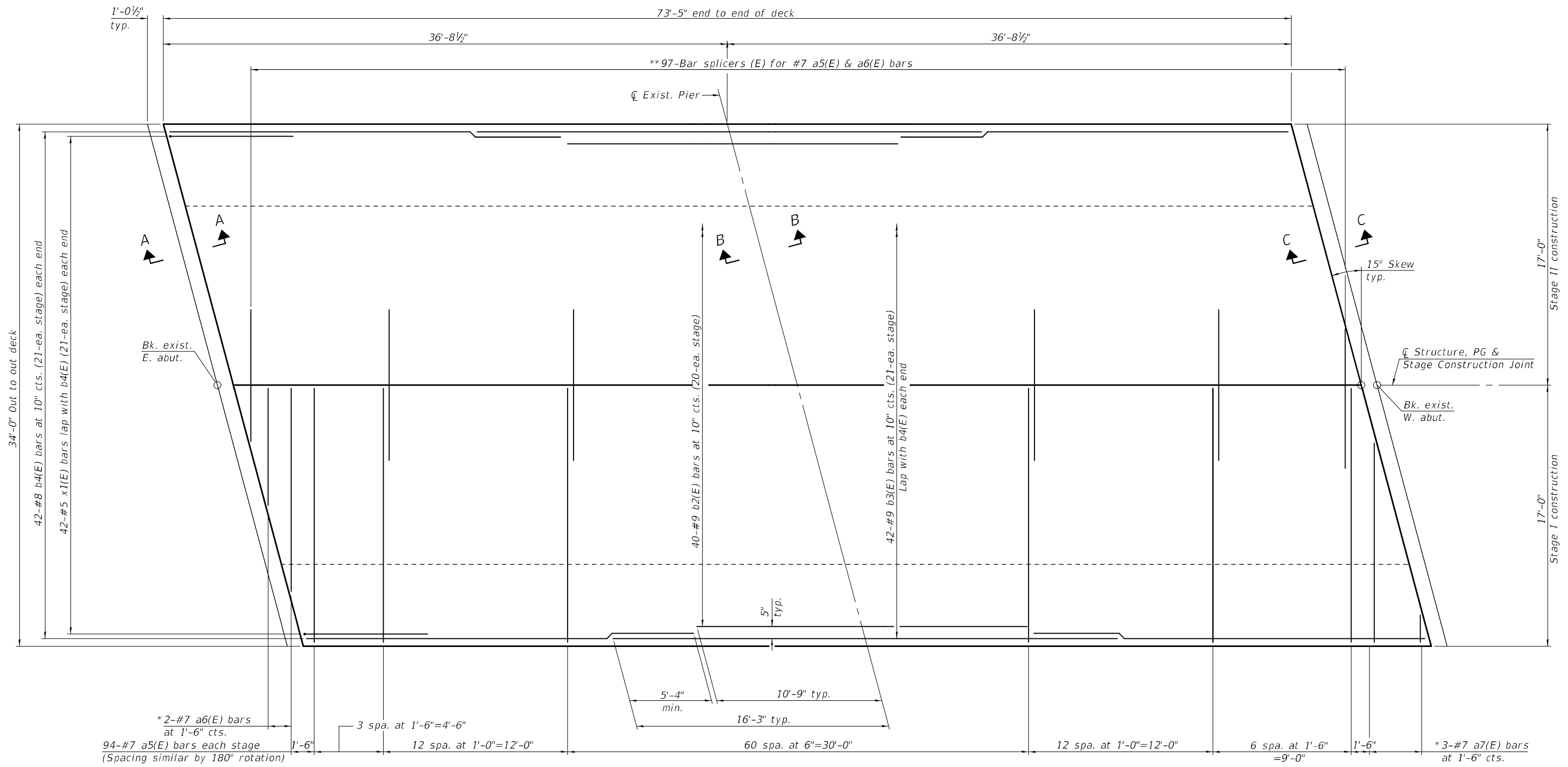

PLAN
(Showing Top Reinforcement)

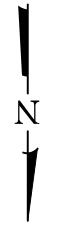

* See Field Cutting Diagram on sheet 13 of 21.
** Trim to fit 1 at east end of Stage I & west end of Stage II.

MODEL: 000000-00000-010
FILE NAME: p:\w\pwbentley.com\FWIDOT\Documents\Bureau of Bridges and Structures\Projects\0960064\CADD Plans\0960064-74857.dgn

DESIGNED -	ANDREW DIORIO
CHECKED -	PAUL JOHNSON
DRAWN -	ANDRO R. SAMANIEGO
CHECKED -	A.M.D. / P.S.J.

EXAMINED	<i>Mark Shuffler</i> ENGINEER OF BRIDGE DESIGN
PASSED	<i>Jaime F. ...</i> ENGINEER OF BRIDGES AND STRUCTURES

DATE -	MARCH 27, 2024
REVISED -	
REVISED -	

**STATE OF ILLINOIS
DEPARTMENT OF TRANSPORTATION**

**SUPERSTRUCTURE TOP MAT
STRUCTURE NO. 096-0064**

SHEET 10 OF 21 SHEETS

F.A.P. RTE.	SECTION	COUNTY	TOTAL SHEETS	SHEET NO.
823	(24BR-1)BR	WAYNE	57	28
CONTRACT NO. 74857				
ILLINOIS FED. AID PROJECT				

MODEL: 000000-00000-011
 FILE NAME: p:\w\l\p-w\benley.com\FW\DOT Documents\Bureau of Bridges and Structures\DOT Offices\CADD Plans\0960064-74857.dgn

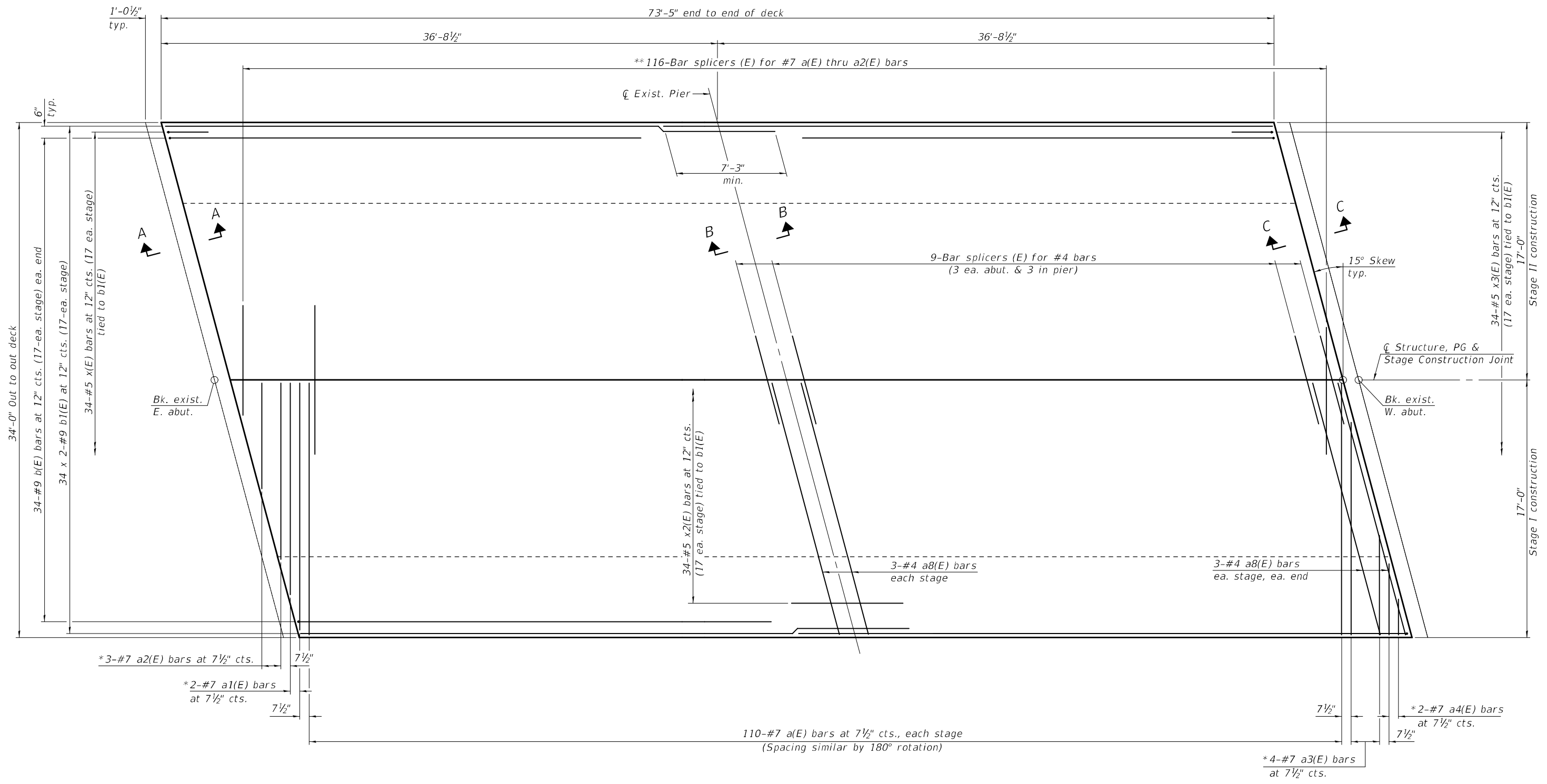

PLAN
 (Showing Bottom Reinforcement)

Note:
 Bars indicated thus 34 x 2-#9 indicates
 34 lines of bars with 2 lengths per line.

* See Field Cutting Diagram on sheet 13 of 21.
 ** Trim to fit 2 at east end of Stage I & west end of Stage II.

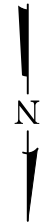

DESIGNED -	ANDREW DIORIO
CHECKED -	PAUL JOHNSON
DRAWN -	ANDRO R. SAMANIEGO
CHECKED -	A.M.D. / P.S.J.

EXAMINED	<i>Mark Shuffler</i> ENGINEER OF BRIDGE DESIGN
PASSED	<i>Joey F. [Signature]</i> ENGINEER OF BRIDGES AND STRUCTURES

DATE -	MARCH 27, 2024
REVISED -	
REVISED -	

STATE OF ILLINOIS
DEPARTMENT OF TRANSPORTATION

SUPERSTRUCTURE BOTTOM MAT
STRUCTURE NO. 096-0064

SHEET 11 OF 21 SHEETS

F.A.P. RTE.	SECTION	COUNTY	TOTAL SHEETS	SHEET NO.
823	(24BR-1)BR	WAYNE	57	29
ILLINOIS FED. AID PROJECT			CONTRACT NO. 74857	

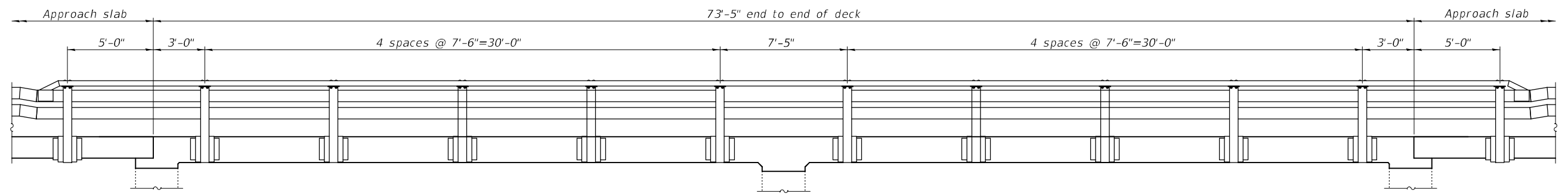
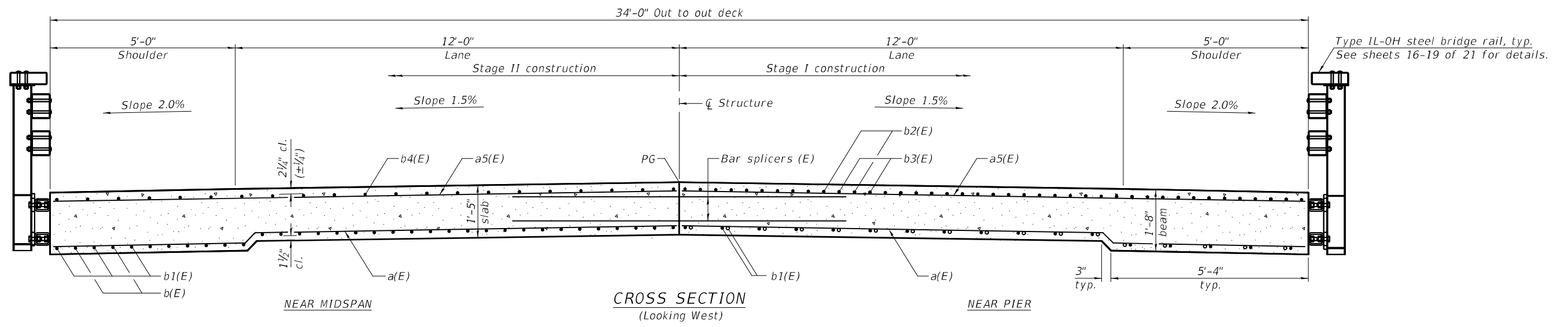

* 1'-3" at control points. See details on sheet 13 of 21.

For details of all s & v bars in Section A-A thru C-C, see sheet 20 of 21.

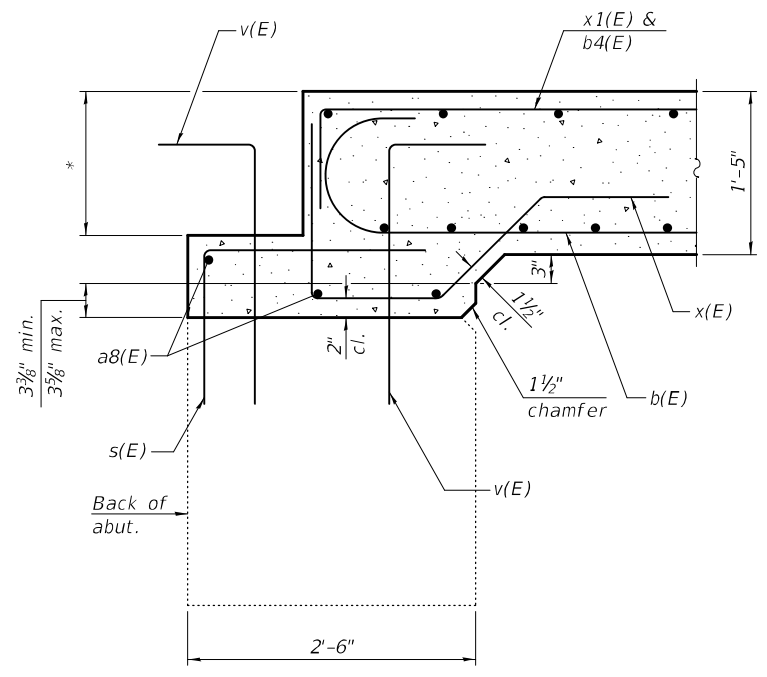

SECTION A-A
(Horizontal dimensions are at right L's)

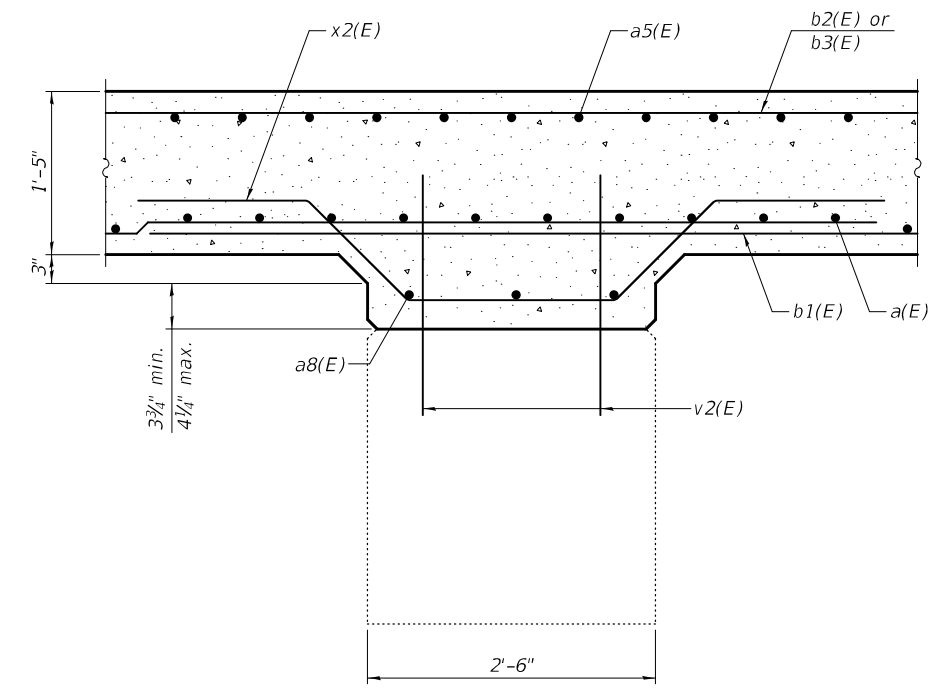

SECTION B-B
(Horizontal dimensions are at right L's)

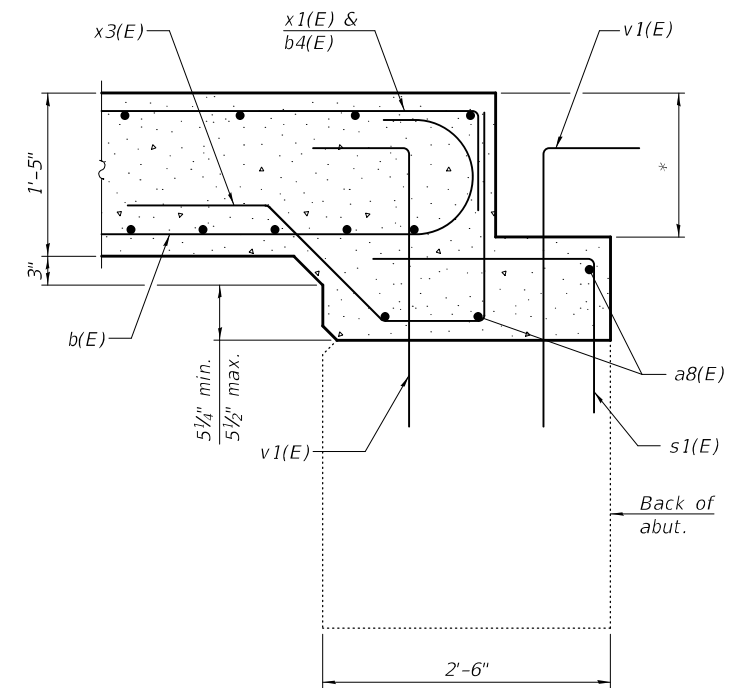

SECTION C-C
(Horizontal dimensions are at right L's)

MODEL: 000000-00000-012
FILE NAME: p:\w\p\w\benley.com\FWIDOT\Documents\Bridges and Structures\Projects\0960064\CADD Plans\0960064-74857.dgn
3/28/2024 9:28:18 AM

DESIGNED -	ANDREW DIORIO
CHECKED -	PAUL JOHNSON
DRAWN -	ANDRO R. SAMANIEGO
CHECKED -	A.M.D. / P.S.J.

EXAMINED	<i>Mark Shuffler</i> ENGINEER OF BRIDGE DESIGN	DATE -	MARCH 27, 2024
PASSED	<i>Jaime F. ...</i> ENGINEER OF BRIDGES AND STRUCTURES	REVISED -	
		REVISED -	

STATE OF ILLINOIS
DEPARTMENT OF TRANSPORTATION

SUPERSTRUCTURE DETAILS
STRUCTURE NO. 096-0064

SHEET 12 OF 21 SHEETS

F.A.P. RTE.	SECTION	COUNTY	TOTAL SHEETS	SHEET NO.
823	(24BR-1)BR	WAYNE	57	30
CONTRACT NO. 74857				
ILLINOIS FED. AID PROJECT				

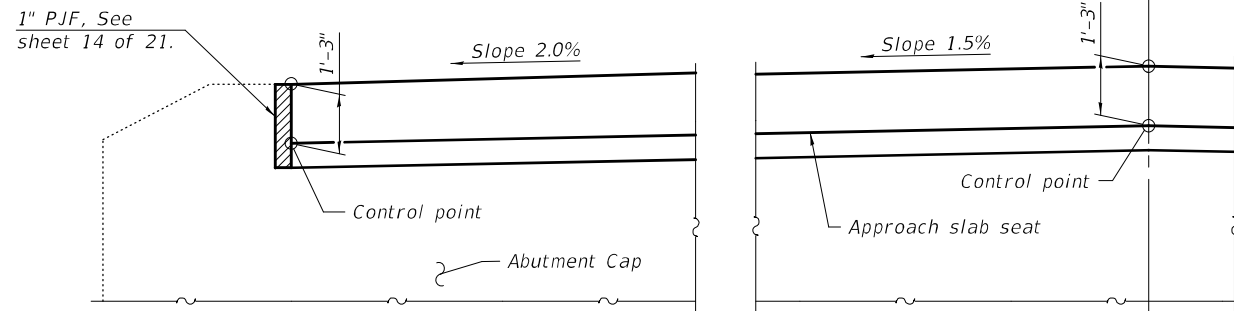

APPROACH SLAB SEAT

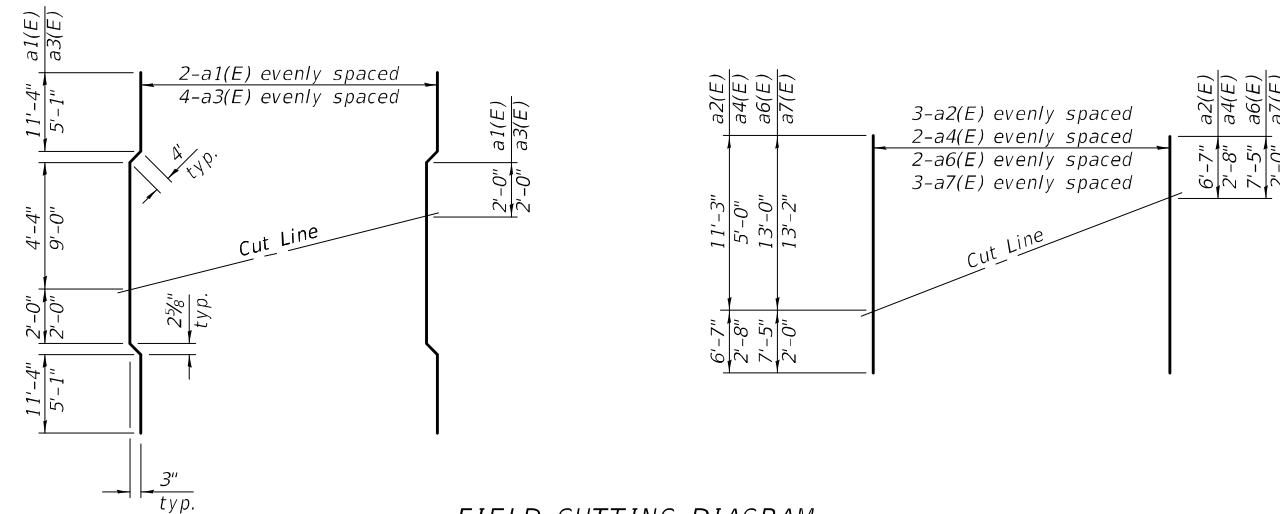

FIELD CUTTING DIAGRAM

Order a1(E), a2(E), a3(E), a4(E), a6(E) and a7(E) bars full length. Cut as shown and use a1(E), a2(E) & a6(E) bars at east end of Stage I and west end Stage II. Use a3(E), a4(E) & a7(E) bars at west end of Stage I and east end of Stage II.

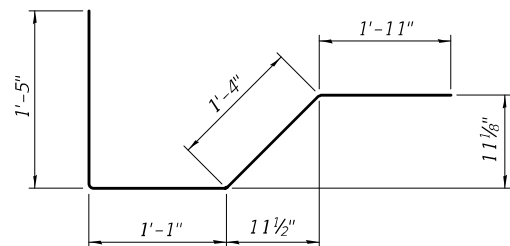

BAR x(E)

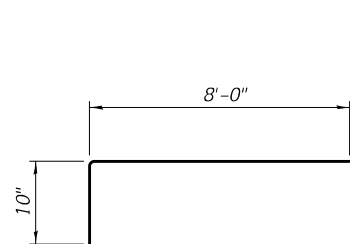

BAR x1(E)

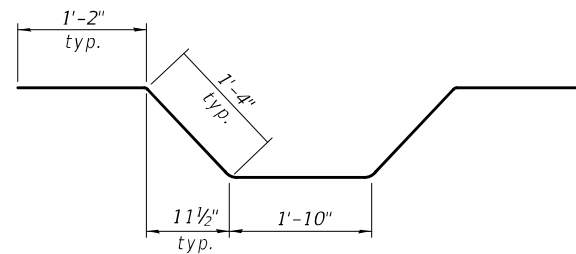

BAR x2(E)

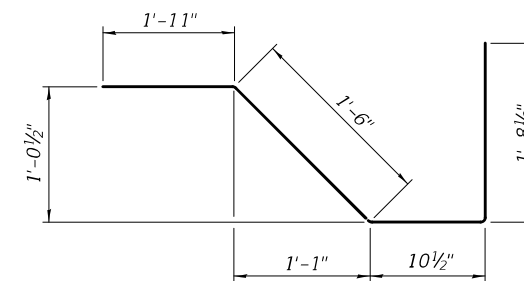

BAR x3(E)

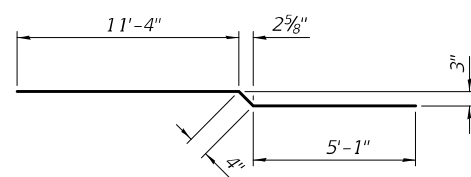

BAR a(E)

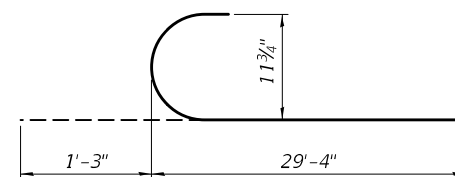

BAR b(E)

**SUPERSTRUCTURE
BILL OF MATERIAL**

Bar	No.	Size	Length	Shape
a(E)	220	#7	16'-9"	—
a1(E)	2	#7	29'-8"	—
a2(E)	3	#7	17'-10"	—
a3(E)	4	#7	21'-10"	—
a4(E)	2	#7	7'-8"	—
a5(E)	188	#7	16'-8"	—
a6(E)	2	#7	20'-5"	—
a7(E)	3	#7	15'-2"	—
a8(E)	18	#4	17'-3"	—
b(E)	68	#9	30'-7"	U
b1(E)	68	#9	40'-3"	—
b2(E)	40	#9	21'-6"	—
b3(E)	42	#9	32'-6"	—
b4(E)	84	#8	25'-8"	—
x(E)	34	#5	5'-9"	S
x1(E)	84	#5	8'-10"	—
x2(E)	34	#5	6'-10"	—
x3(E)	34	#5	6'-0"	—
Reinforcement Bars, Epoxy Coated			Pound	45,890
Concrete Superstructure			Cu. Yd.	143.6

MODEL: 000000-00000-013
FILE NAME: p:\w\p\w\benley.com\FWIDOT\Documents\DOT Offices\Bureau of Bridges and Structures\Projects\0960064\CADD Plans\0960064-74857.dgn

DESIGNED - ANDREW DIORIO
CHECKED - PAUL JOHNSON
DRAWN - ANDRO R. SAMANIEGO
CHECKED - A.M.D. / P.S.J.

EXAMINED
PASSED
Mark Shuffler
ENGINEER OF BRIDGE DESIGN
Jayne F. [Signature]
ENGINEER OF BRIDGES AND STRUCTURES

DATE - MARCH 27, 2024
REVISED -
REVISED -

**STATE OF ILLINOIS
DEPARTMENT OF TRANSPORTATION**

**SUPERSTRUCTURE DETAILS
STRUCTURE NO. 096-0064**

SHEET 13 OF 21 SHEETS

F.A.P. RTE.	SECTION	COUNTY	TOTAL SHEETS	SHEET NO.
823	(24BR-1)BR	WAYNE	57	31
			CONTRACT NO. 74857	
		ILLINOIS FED. AID PROJECT		

3/28/2024 9:28:19 AM

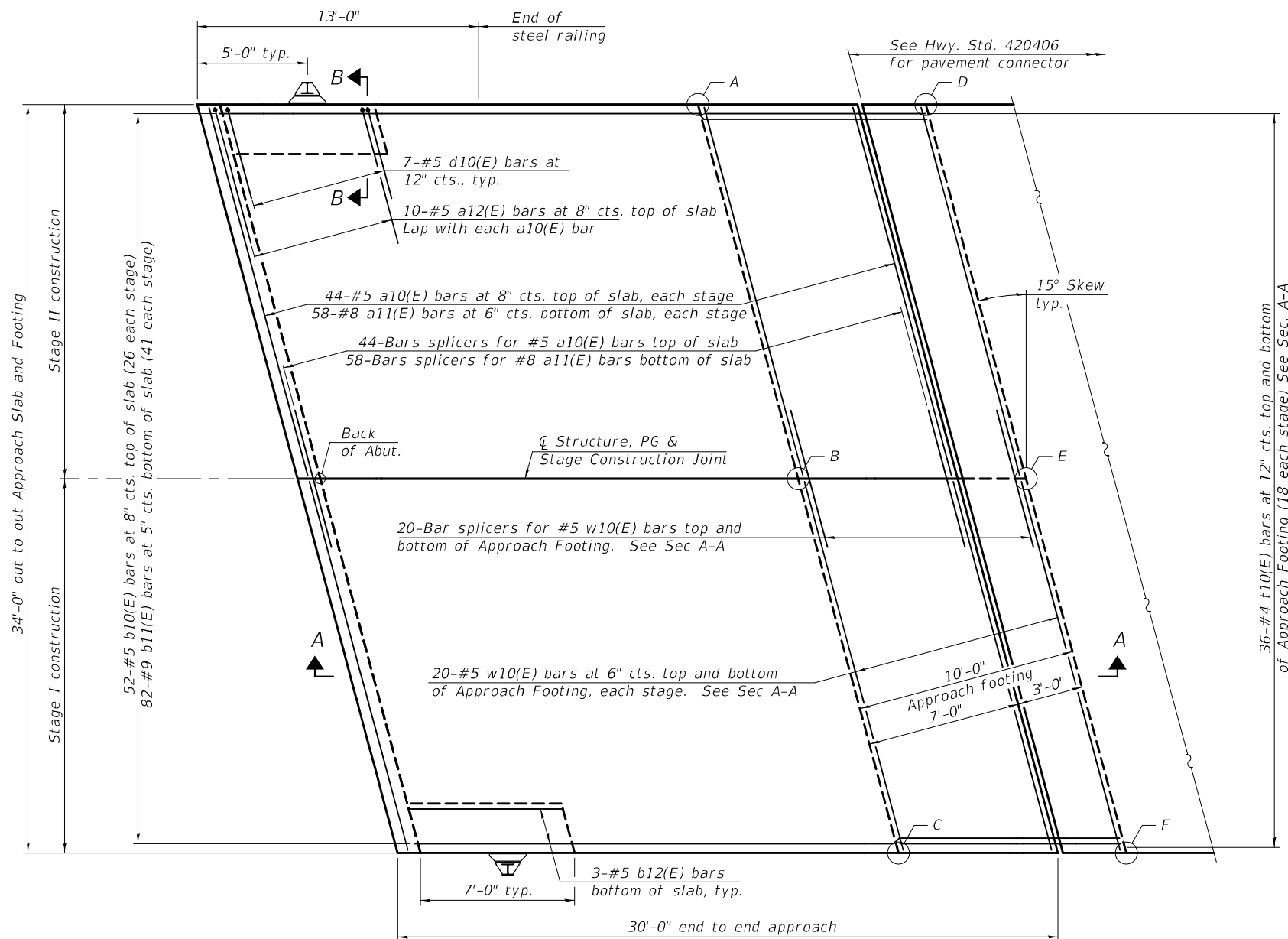
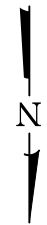

PLAN

(West approach slab shown; East approach slab similar by 180° rotation)

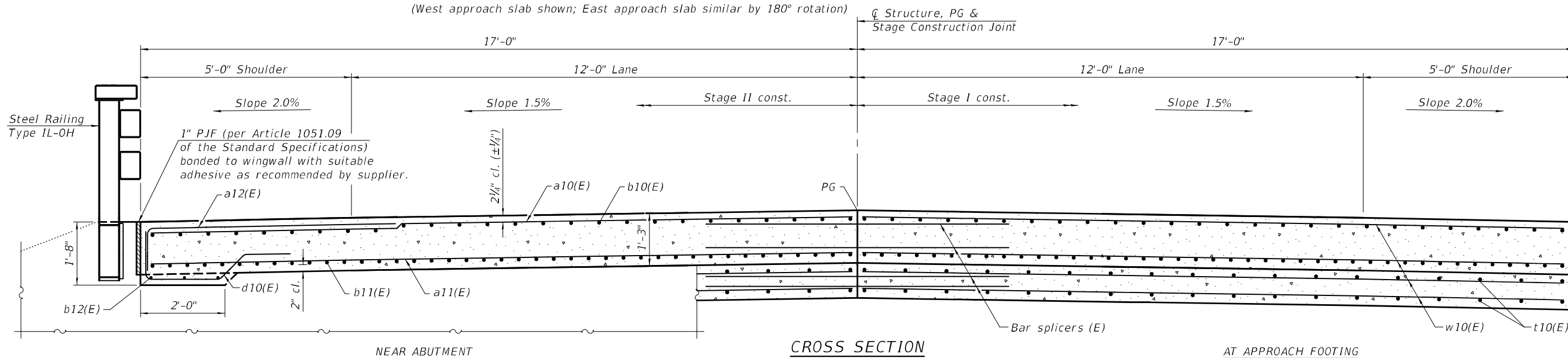

CROSS SECTION

(Looking West)

AT APPROACH FOOTING

**TOP AND BOTTOM ELEVATIONS
FOR APPROACH FOOTING**

Point/ Location	East Approach		West Approach		
	Top	Bottom	Top	Bottom	
A - NW	415.91	415.08	A - SE	416.23	415.40
B - W \bar{C}	416.18	415.35	B - E \bar{C}	416.55	415.72
C - SW	415.90	415.07	C - NE	416.31	415.48
D - NE	415.90	415.07	D - SW	416.32	415.49
E - E \bar{C}	416.17	415.34	E - W \bar{C}	416.64	415.81
F - SE	415.89	415.06	F - NW	416.41	415.58

MODEL: 000000-00000-014
FILE NAME: p:\w\p\w\benley.com\FW\DOT\Documents\DOT Offices\Bureau of Bridges and Structures\Projects\0960064\CADD Plans\0960064-74857.dgn
3/28/2024 9:28:21 AM

DESIGNED - ANDREW DIORIO
CHECKED - PAUL JOHNSON
DRAWN - ANDRO R. SAMANIEGO
CHECKED - A.M.D./P.S.J.

EXAMINED
PASSED
Mark Shuffler
ENGINEER OF BRIDGE DESIGN
Jayne F. [Signature]
ENGINEER OF BRIDGES AND STRUCTURES

DATE - MARCH 27, 2024
REVISED -
REVISED -

**STATE OF ILLINOIS
DEPARTMENT OF TRANSPORTATION**

**BRIDGE APPROACH SLAB DETAILS
STRUCTURE NO. 096-0064**

SHEET 14 OF 21 SHEETS

F.A.P. RTE.	SECTION	COUNTY	TOTAL SHEETS	SHEET NO.
823	(24BR-1)BR	WAYNE	57	32
CONTRACT NO. 74857				

ILLINOIS FED. AID PROJECT

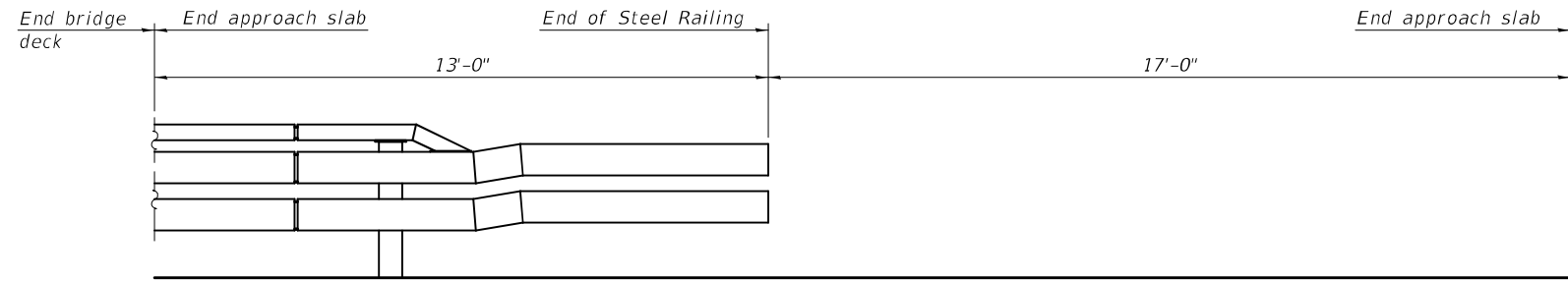

INSIDE ELEVATION OF RAILING

Notes:
 Approach slab shall be paid for as Concrete Superstructure (Approach Slab).
 Approach footing concrete shall be paid for as Concrete Structures.
 The approach footing maximum applied service bearing pressure (Qmax) = 2.0 ksf.
 Cost of excavation for approach footing included with Concrete Structures.
 For Granular Backfill for Structures and drainage treatment details, see sheet 2 of 21.
 For railing details, see sheets 16-19 of 21.

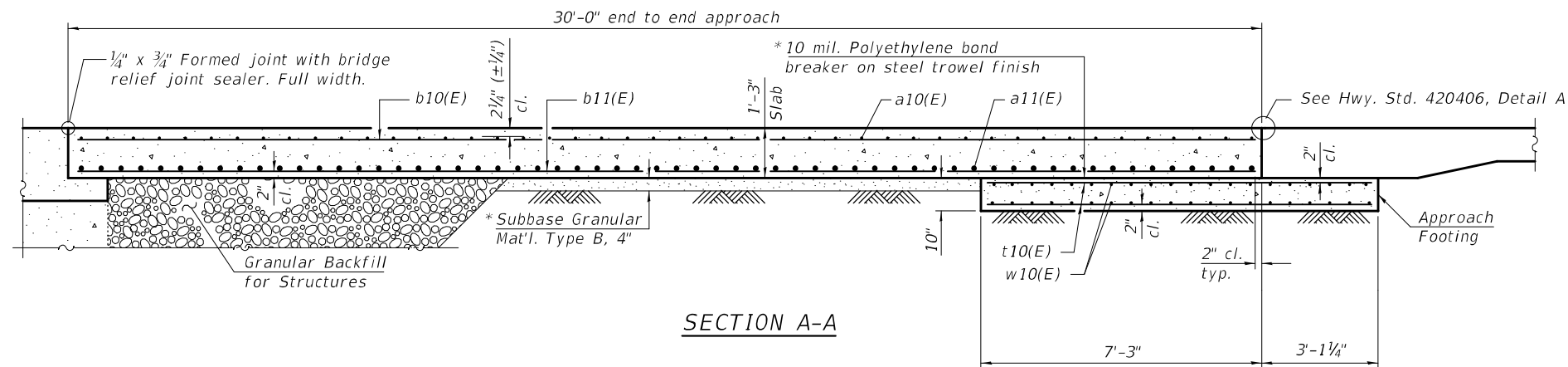

SECTION A-A

TWO APPROACHES
 BILL OF MATERIAL

Bar	No.	Size	Length	Shape
a10(E)	176	#5	17'-3"	—
a11(E)	232	#8	17'-3"	—
a12(E)	40	#5	7'-8"	—
b10(E)	104	#5	29'-8"	—
b11(E)	164	#9	29'-8"	—
b12(E)	12	#5	6'-8"	—
d10(E)	28	#5	5'-1"	└
t10(E)	144	#4	10'-0"	—
w10(E)	160	#5	17'-3"	—
Concrete Superstructure (Approach Slab)		Cu. Yd.	95.4	
Concrete Structures		Cu. Yd.	21.7	
Reinforcement Bars, Epoxy Coated		Pound	38,000	

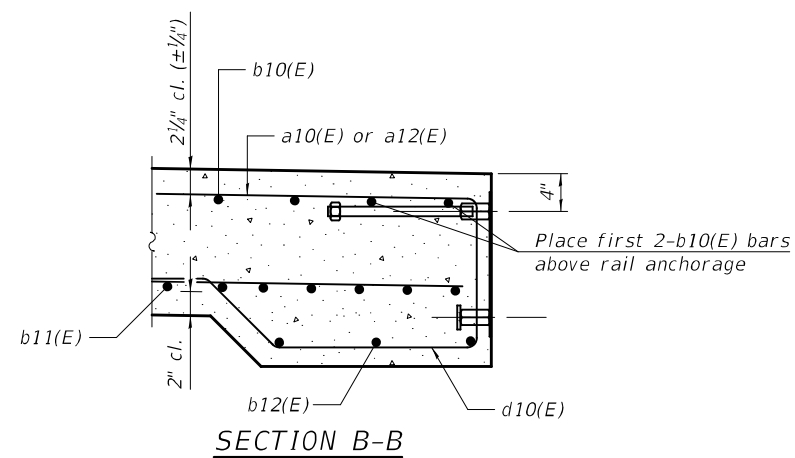

SECTION B-B

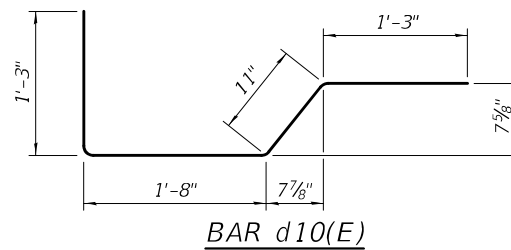

BAR d10(E)

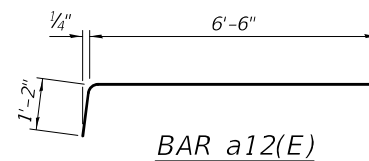

BAR a12(E)

MODEL: 000000-00000-015
 FILE NAME: p:\w\p\w\benley.com\FWIDOT\Documents\DOT Offices\Bureau of Bridges and Structures\Projects\0960064\CADD Plans\0960064-74857.dgn
 3/28/2024 9:28:22 AM

DESIGNED - ANDREW DIORIO
 CHECKED - PAUL JOHNSON
 DRAWN - ANDRO R. SAMANIEGO
 CHECKED - A.M.D./P.S.J.

EXAMINED
 PASSED

ENGINEER OF BRIDGE DESIGN

 ENGINEER OF BRIDGES AND STRUCTURES

DATE - MARCH 27, 2024
 REVISED -
 REVISED -

STATE OF ILLINOIS
 DEPARTMENT OF TRANSPORTATION

BRIDGE APPROACH SLAB DETAILS
 STRUCTURE NO. 096-0064

SHEET 15 OF 21 SHEETS

F.A.P. RTE.	SECTION	COUNTY	TOTAL SHEETS	SHEET NO.
823	(24BR-1)BR	WAYNE	57	33
ILLINOIS FED. AID PROJECT			CONTRACT NO. 74857	

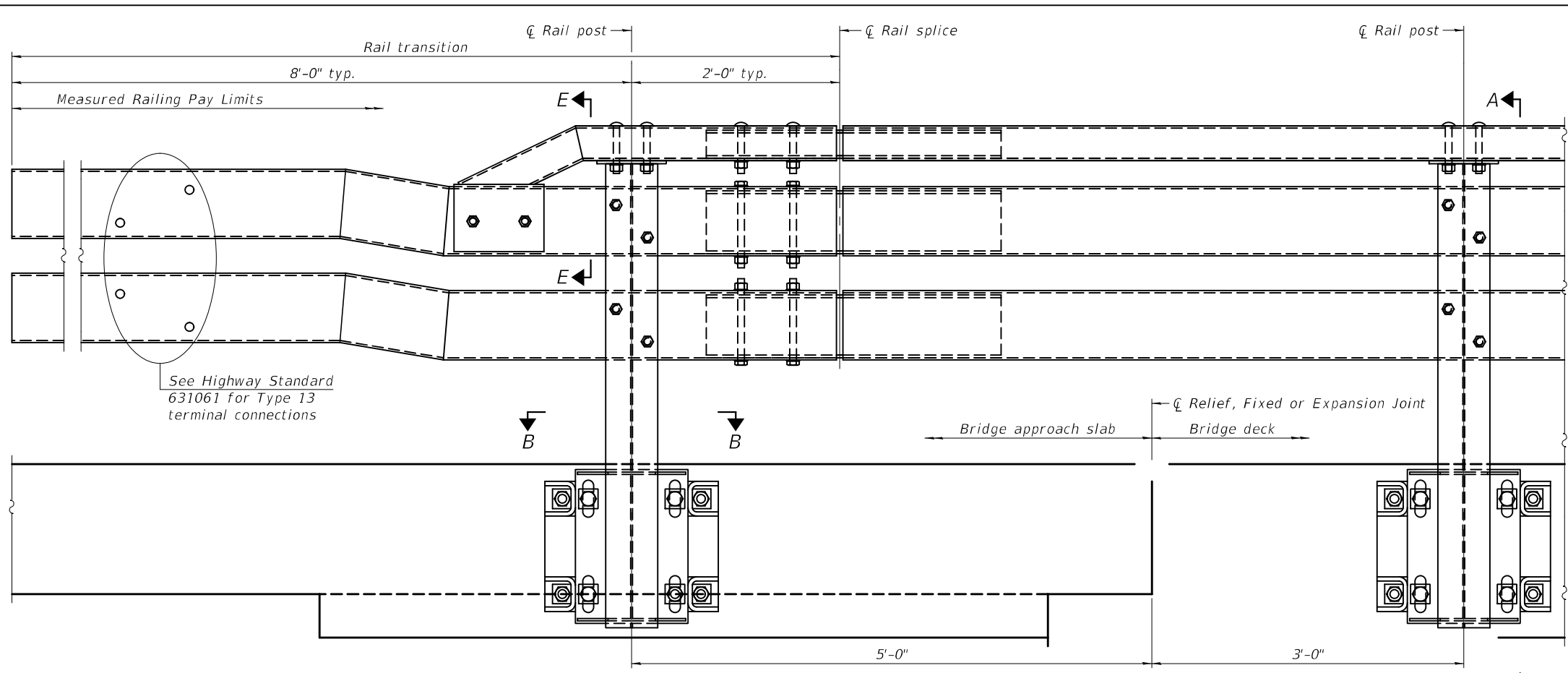

See Highway Standard 631061 for Type 13 terminal connections

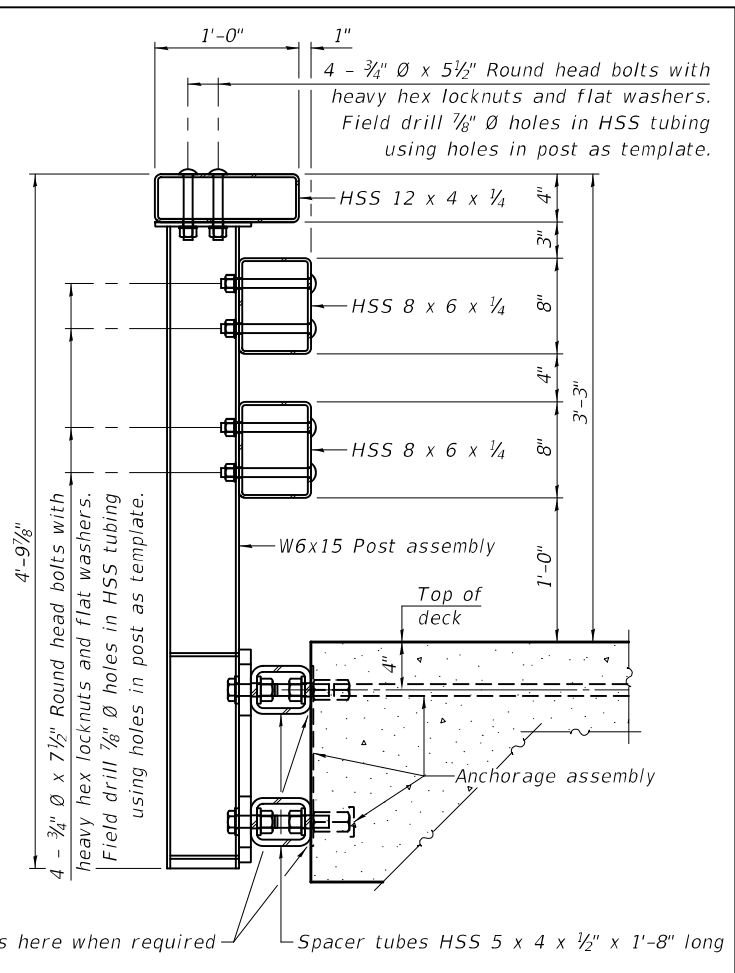

Place shims here when required. Spacer tubes HSS 5 x 4 x 1/2 x 1'-8" long

SECTION A-A

OUTSIDE ELEVATION OF RAIL

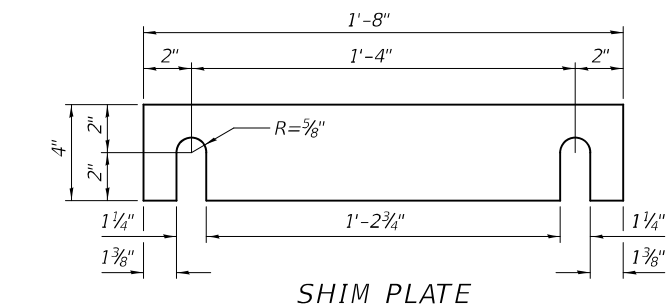

SHIM PLATE

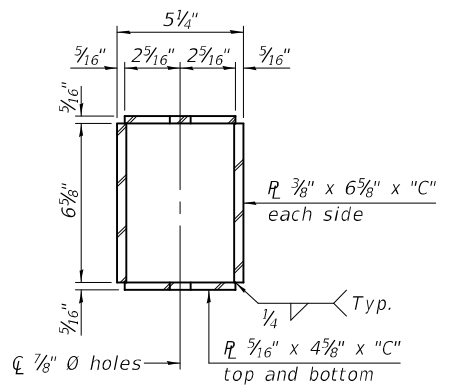

SECTION C-C

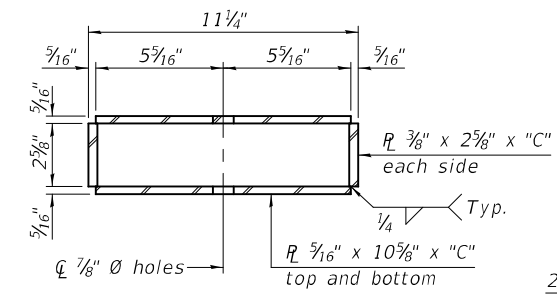

SECTION D-D

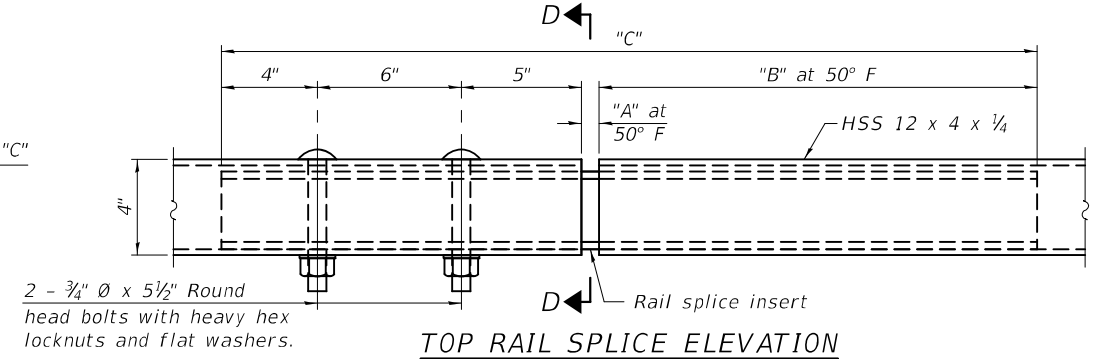

TOP RAIL SPLICE ELEVATION

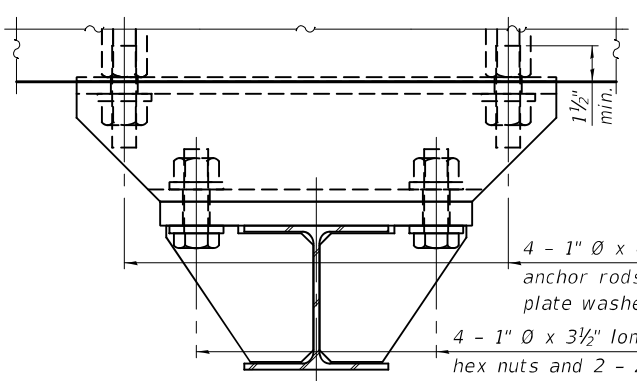

SECTION B-B

4 - 1" \varnothing x 4 1/4" long fully threaded anchor rods with 2 1/4" x 2 1/4" x 5/16" plate washers and heavy hex nuts.
4 - 1" \varnothing x 3 1/2" long H.S. bolts with heavy hex nuts and 2 - 2 1/4" x 2 1/4" x 5/16" plate washers one under head and one under nut.

SPLICE DIMENSIONS

Location	T	A	B	C
All locs. not over exp. jts.	0	1/2"	1'-6"	2'-9 1/2"
Over Strip Seal Jt.	$\leq 4"$	2 1/2"	1'-8"	3'-1 1/2"
Over Finger or Modular Jt.	$\leq 9 1/2"$	5 1/2"	1'-10 3/4"	3'-7 1/4"
Over Finger or Modular Jt.	$\leq 15"$	8 1/4"	2'-1 1/2"	4'-0 3/4"

T = ; total movement along centerline of roadway at expansion joint.

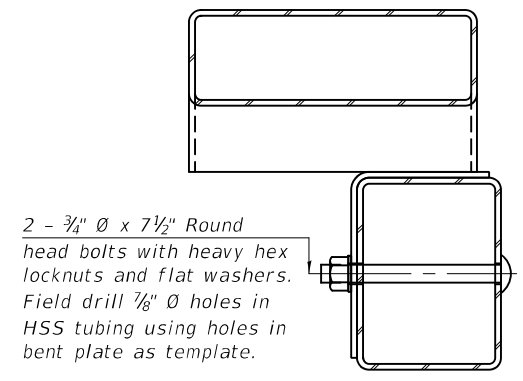

SECTION E-E

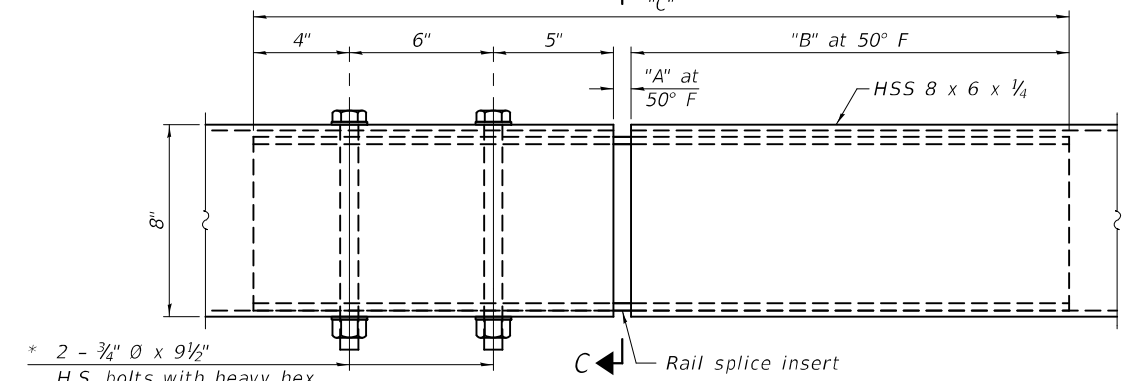

MIDDLE & BOTTOM RAIL SPLICE ELEVATION

* Bolt orientation shown for middle rail. Flip for bottom rail.

RAILING CRITERIA

MASH 2016 Test Level	4
Rail system weight (plf)	120
Max post spacing	8'-0"

R-40BD 10-12-2021

DESIGNED - ANDREW DIORIO
CHECKED - PAUL JOHNSON
DRAWN - ANDRO R. SAMANIEGO
CHECKED - A.M.D. / P.S.J.

EXAMINED
PASSED
Mark Shuffler
ENGINEER OF BRIDGE DESIGN
Jayne F. Schuff
ENGINEER OF BRIDGES AND STRUCTURES

DATE - MARCH 27, 2024
REVISED -
REVISED -

STATE OF ILLINOIS
DEPARTMENT OF TRANSPORTATION

STEEL RAILING, TYPE IL-OH
STRUCTURE NO. 096-0064

SHEET 16 OF 21 SHEETS

F.A.P. RTE.	SECTION	COUNTY	TOTAL SHEETS	SHEET NO.
823	(24BR-1)BR	WAYNE	57	34
CONTRACT NO. 74857				
ILLINOIS FED. AID PROJECT				

MODEL: 000000-00000-016
FILE NAME: p:\w\p-w-bentley.com\FWIDOT\Documents\DOT Offices\Bureau of Bridges and Structures\Projects\0960064\CADD Plans\0960064-74857.dgn
3/28/2024 9:28:22 AM

(Sheet 1 of 4)

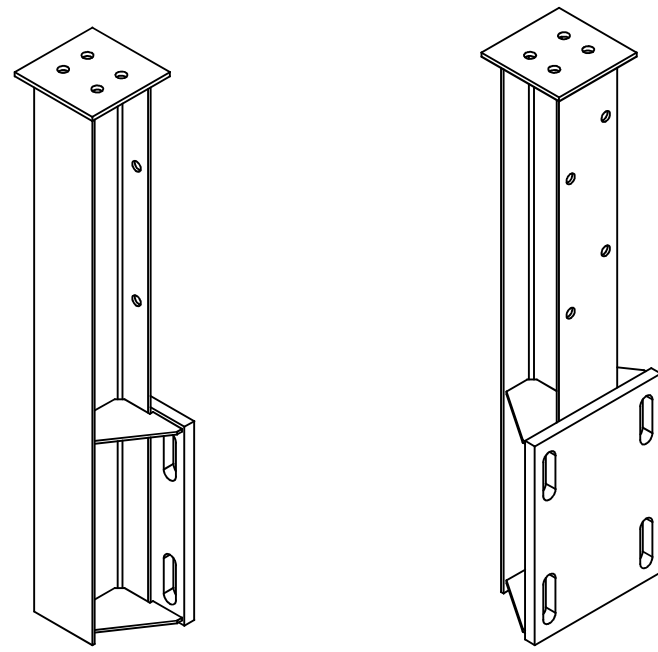

ISOMETRIC VIEWS POST ASSEMBLY

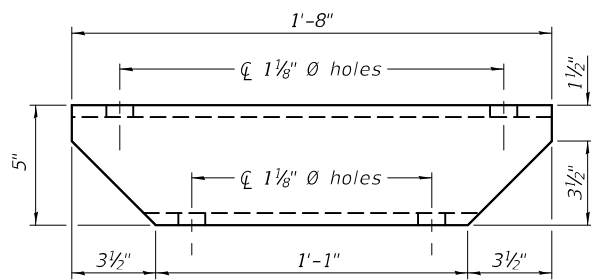

SPACER TUBE PLAN

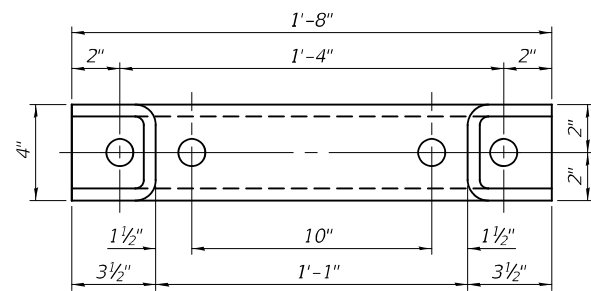

SPACER TUBE ELEVATION

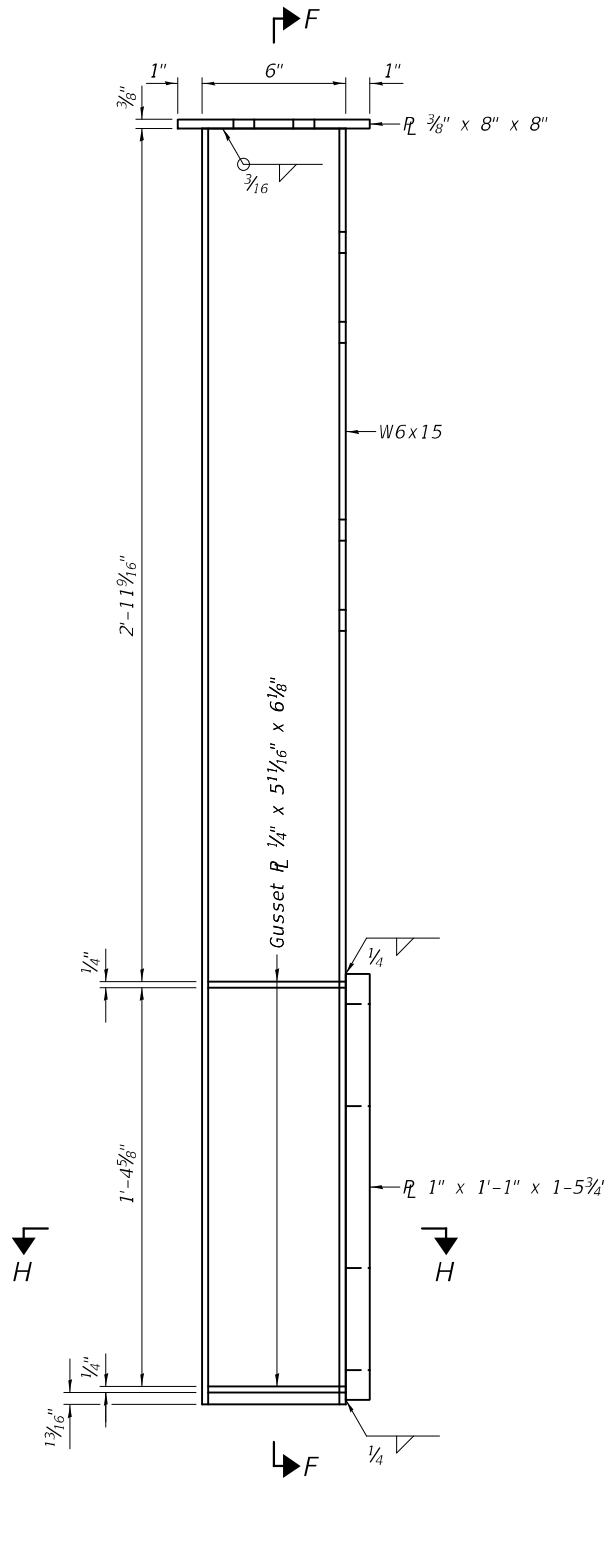

SIDE ELEVATION POST ASSEMBLY

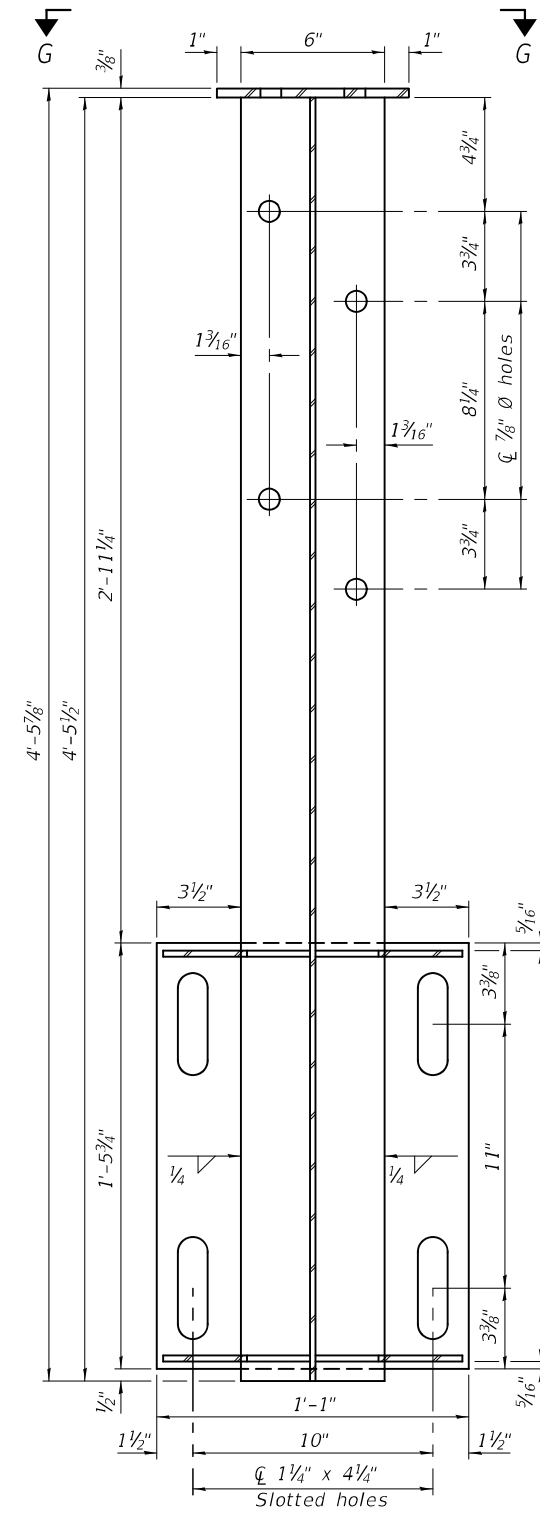

SECTION F-F

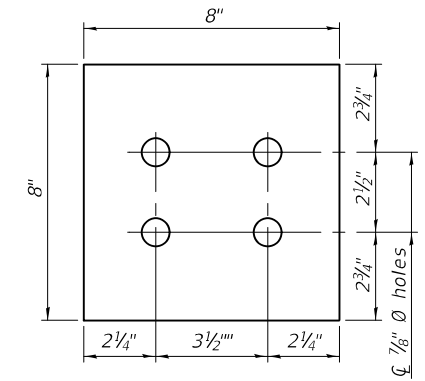

VIEW G-G
(Showing top plate)

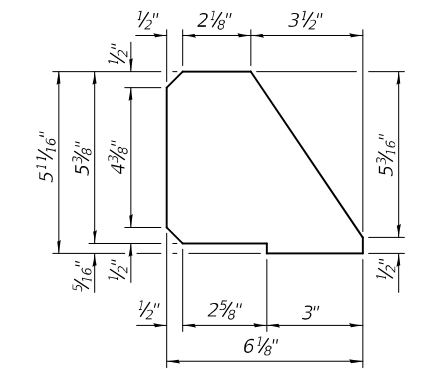

GUSSET PLATE

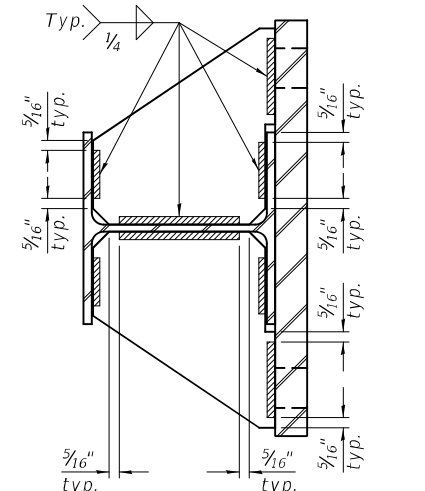

SECTION H-H
(Showing gusset plate welds)

(Sheet 2 of 4)

MODEL: 000000-00000-017
FILE NAME: p:\w\pwbentley.com\FWIDOT\Documents\DOT Offices\Bureau of Bridges and Structures\Projects\0960064\CADD Plans\0960064-74857.dgn

R-40BD

10-12-2021

DESIGNED -	ANDREW DIORIO
CHECKED -	PAUL JOHNSON
DRAWN -	ANDRO R. SAMANIEGO
CHECKED -	A.M.D. / P.S.J.

EXAMINED	<i>Mark Shuffler</i> ENGINEER OF BRIDGE DESIGN
PASSED	<i>Jayne F. [Signature]</i> ENGINEER OF BRIDGES AND STRUCTURES

DATE -	MARCH 27, 2024
REVISED -	
REVISED -	

STATE OF ILLINOIS
DEPARTMENT OF TRANSPORTATION

STEEL RAILING, TYPE IL-OH
STRUCTURE NO. 096-0064

SHEET 17 OF 21 SHEETS

F.A.P. RTE.	SECTION	COUNTY	TOTAL SHEETS	SHEET NO.
823	(24BR-1)BR	WAYNE	57	35
CONTRACT NO. 74857				

ILLINOIS FED. AID PROJECT

3/28/2024 9:28:23 AM

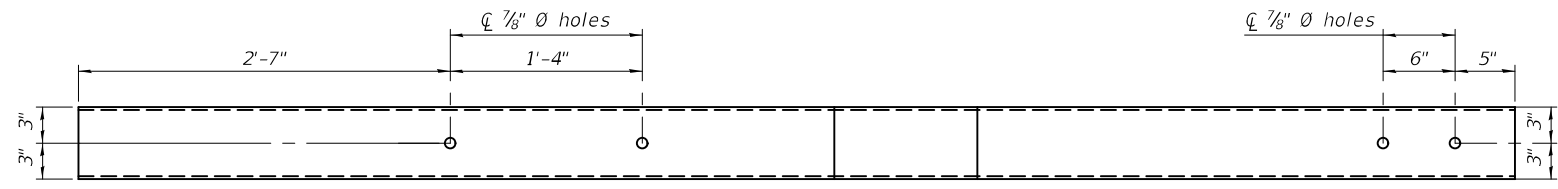

PLAN OF MIDDLE AND BOTTOM RAIL TRANSITION

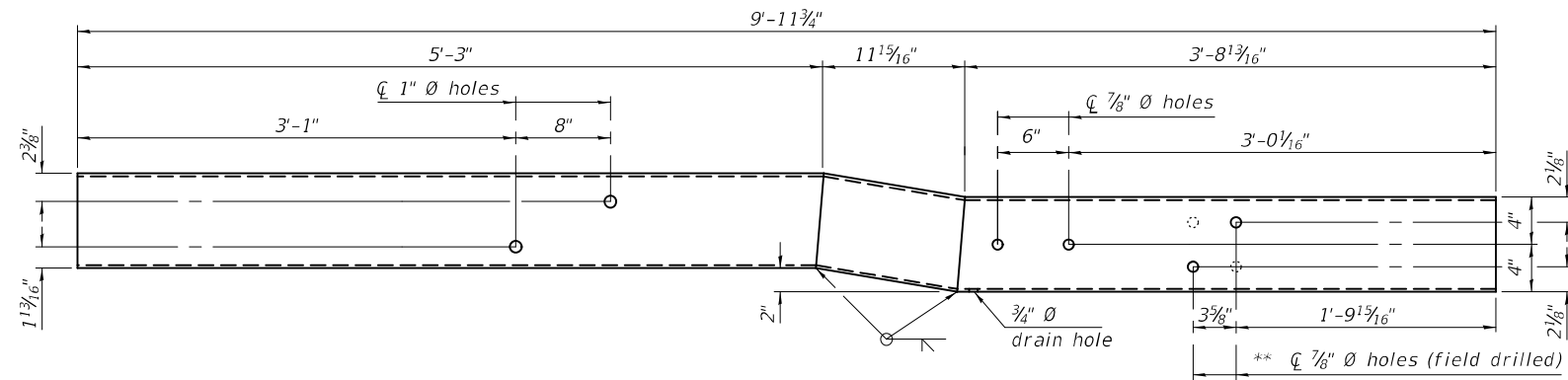

INSIDE ELEVATION OF LEFT MIDDLE RAIL TRANSITION

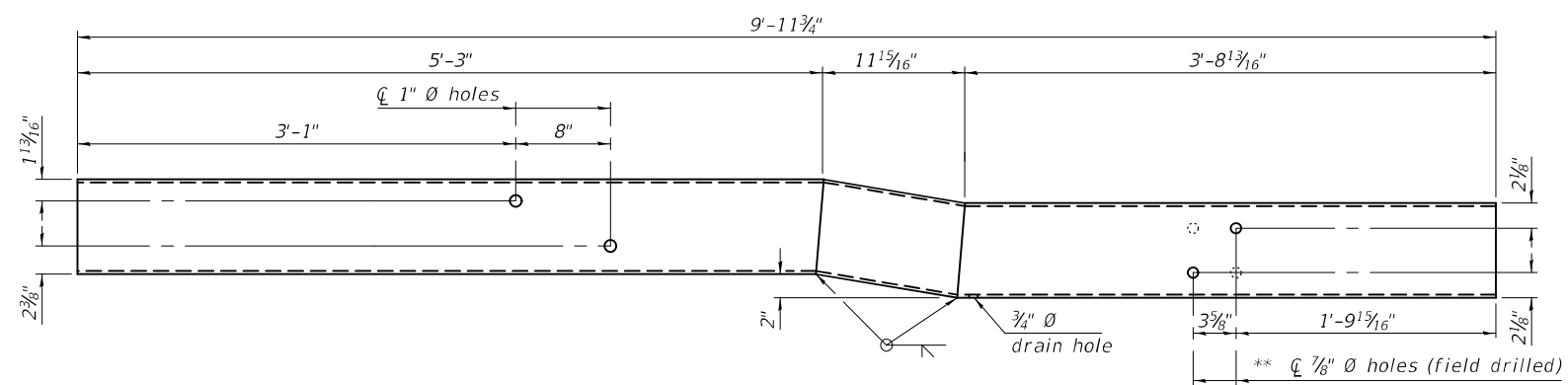

INSIDE ELEVATION OF LEFT BOTTOM RAIL TRANSITION

** Hole orientation is flipped as shown with the dashed holes for the right side piece.

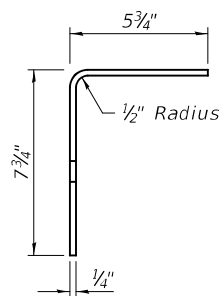

VIEW I-I

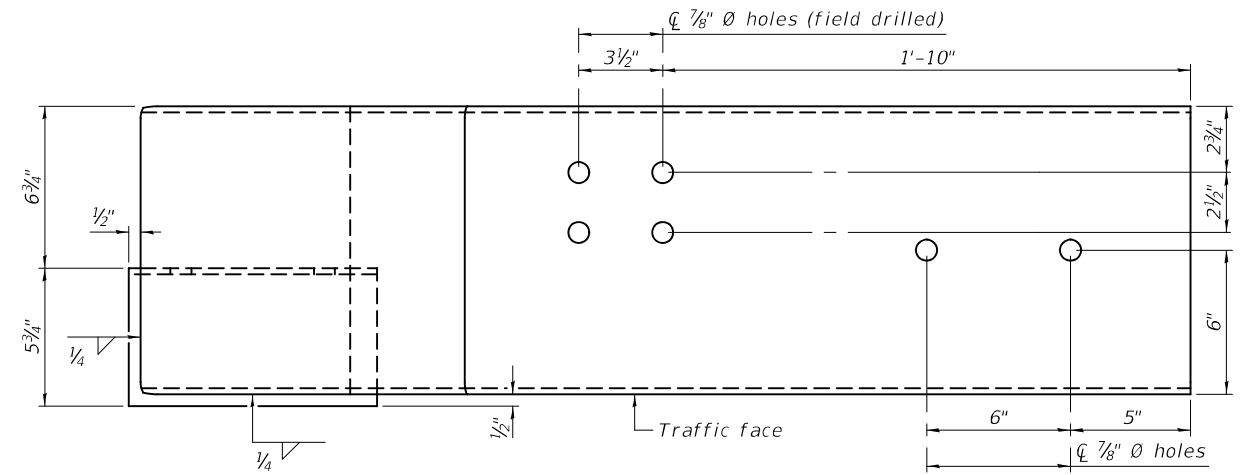

PLAN OF LEFT TOP RAIL TERMINATION ASSEMBLY

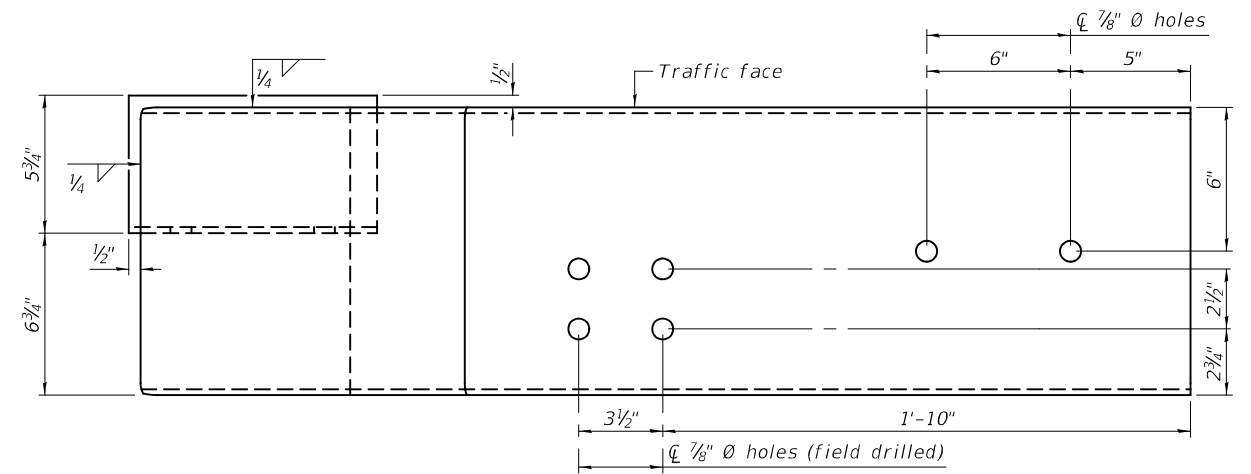

PLAN OF RIGHT TOP RAIL TERMINATION ASSEMBLY

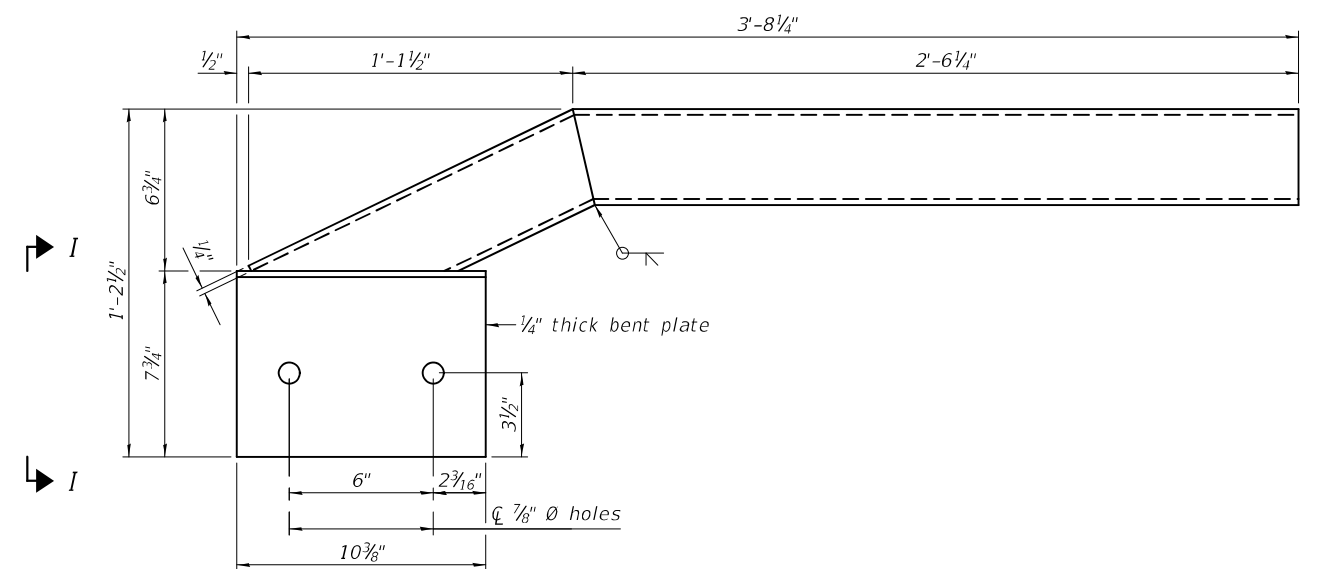

INSIDE ELEVATION OF LEFT TOP RAIL TERMINATION ASSEMBLY
(Right Similar)

(Sheet 3 of 4)

MODEL: 000000-00000-018
FILE NAME: p:\w\pwbentley.com\FWIDOT\Documents\IDOT Offices\Bureau of Bridges and Structures\Projects\0960064\CADD Plans\0960064-74857.dgn

R-40BD

10-12-2021

DESIGNED -	ANDREW DIORIO
CHECKED -	PAUL JOHNSON
DRAWN -	ANDRO R. SAMANIEGO
CHECKED -	A.M.D. / P.S.J.

EXAMINED	<i>Mark Shuffler</i> ENGINEER OF BRIDGE DESIGN
PASSED	<i>Jayne F. Duff</i> ENGINEER OF BRIDGES AND STRUCTURES

DATE -	MARCH 27, 2024
REVISED -	
REVISED -	

STATE OF ILLINOIS
DEPARTMENT OF TRANSPORTATION

STEEL RAILING, TYPE IL-OH
STRUCTURE NO. 096-0064

SHEET 18 OF 21 SHEETS

F.A.P. RTE.	SECTION	COUNTY	TOTAL SHEETS	SHEET NO.
823	(24BR-1)BR	WAYNE	57	36
CONTRACT NO. 74857				

ILLINOIS FED. AID PROJECT

3/28/2024 9:28:23 AM

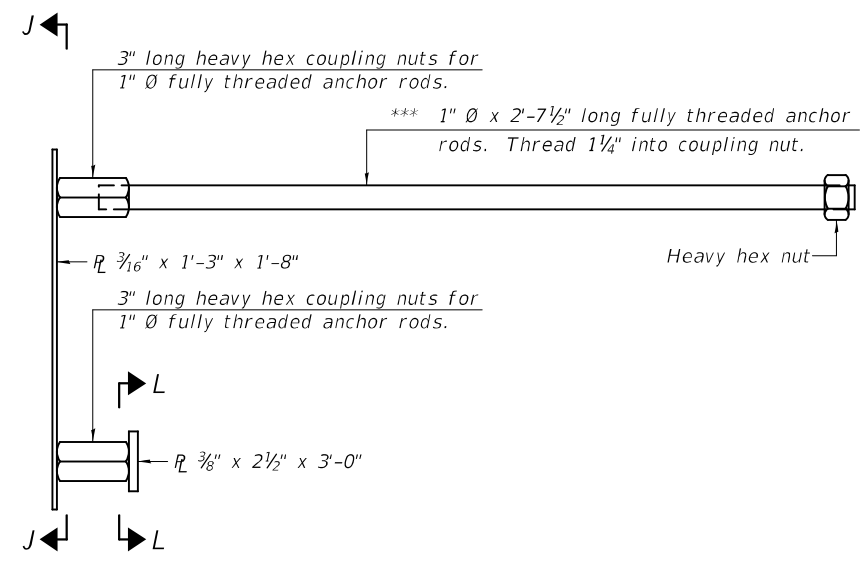

ANCHORAGE ASSEMBLY

*** For skewed bridge decks use 1" Ø x 1'-3" long fully threaded anchor rods at acute corners of bridge deck.

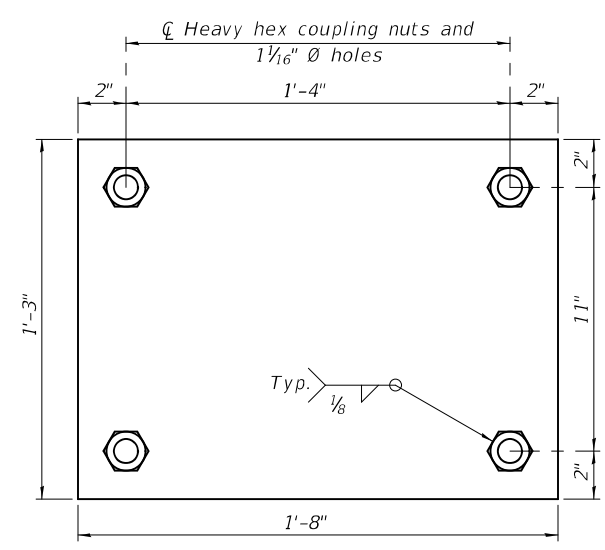

SECTION J-J

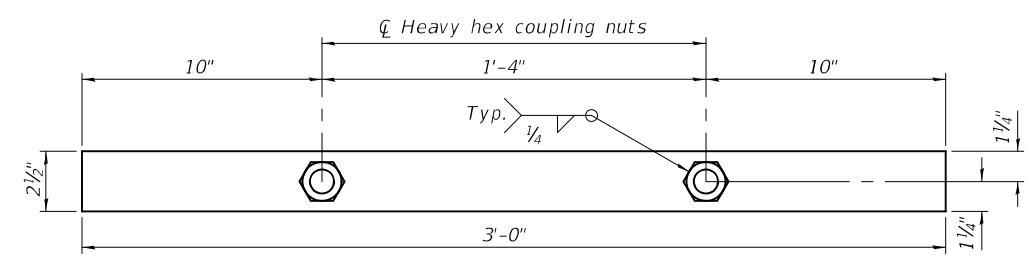

SECTION L-L

Notes:
 All plates shall be AASHTO M270 grade 50.
 All HSS tubing shall be ASTM A500 grade C.
 All heavy hex nuts including heavy hex coupling nuts shall be according to ASTM A563 grade DH.
 All fully threaded anchor rods shall be ASTM F1554 grade 105.
 All round head bolts shall be ASTM A449.
 All steel rail elements including shims shall be galvanized according to Article 509.05 of the Standard Specifications.
 Rail splice inserts may be built out of 2 - 3/8" bent plates in lieu of the 4 plate rail splice inserts shown, provided the outside dimensions are matched.
 A sufficient number shims of various thicknesses, built to the dimensions shown in the shim plate detail, shall be provided to adjust posts for plumbness and horizontal alignment. Cost included with Steel Railing, Type IL-OH.
 The spacer tubes shall be fastened to the bridge deck and bridge approach slab snug tight and given an additional 1/2 turn. The 1" diameter high strength bolts used to connect the spacer tubes to the post assemblies shall be tightened according to Article 505.04(f)(2) of the Standard Specifications.
 All HSS tubing serving as railing shall be CVN tested according to Article 1006.34(b) of the Standard Specifications.

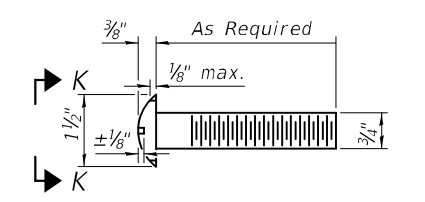

ROUND HEAD BOLT DETAIL

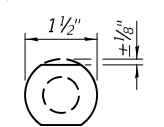
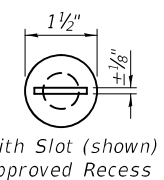

VIEW K-K

BILL OF MATERIAL

Item	Unit	Quantity
Steel Railing, Type IL-OH	Foot	199

MODEL: 000000-00000-019
 FILE NAME: p:\w\p\w\benley.com\FWIDOT\Documents\Bureau of Bridges and Structures\Projects\0960064\CADD Plans\0960064-74857.dgn

R-40BD 10-12-2021

(Sheet 4 of 4)

DESIGNED - ANDREW DIORIO	EXAMINED - <i>Mark Shuffler</i> ENGINEER OF BRIDGE DESIGN	DATE - MARCH 27, 2024
CHECKED - PAUL JOHNSON	PASSED - <i>Jayne F. Cluff</i> ENGINEER OF BRIDGES AND STRUCTURES	REVISED -
DRAWN - ANDRO R. SAMANIEGO		REVISED -
CHECKED - A.M.D. / P.S.J.		

**STATE OF ILLINOIS
 DEPARTMENT OF TRANSPORTATION**

**STEEL RAILING, TYPE IL-OH
 STRUCTURE NO. 096-0064**

F.A.P. RTE.	SECTION	COUNTY	TOTAL SHEETS	SHEET NO.
823	(24BR-1)BR	WAYNE	57	37
			CONTRACT NO. 74857	
		ILLINOIS	FED. AID PROJECT	

SHEET 19 OF 21 SHEETS

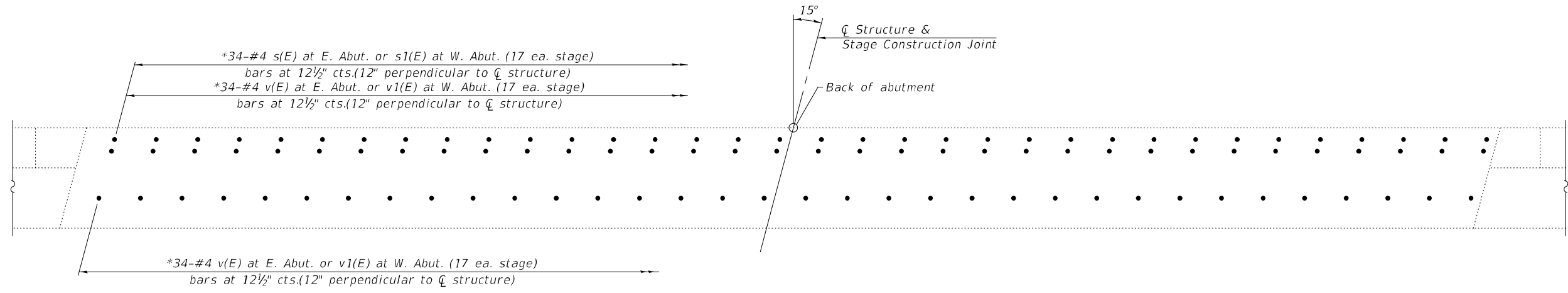

PLAN - EAST ABUTMENT
(West abutment similar)

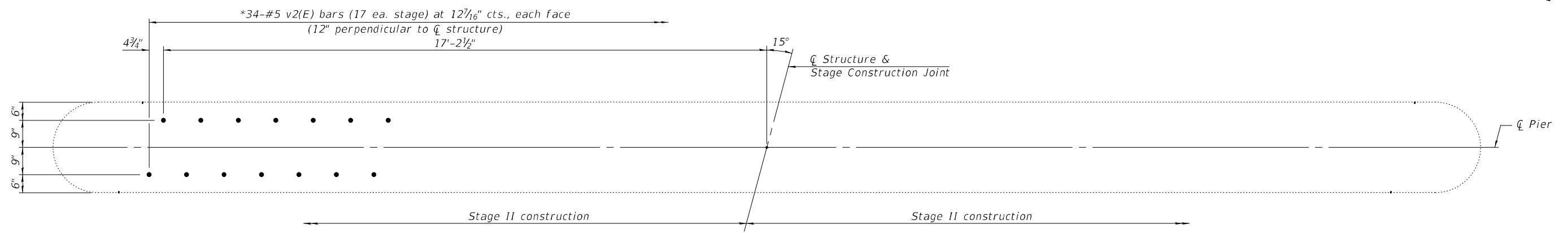

PLAN - PIER

* Drill and grout 9" min. into cap in accordance with Article 584 of the Standard Specifications.

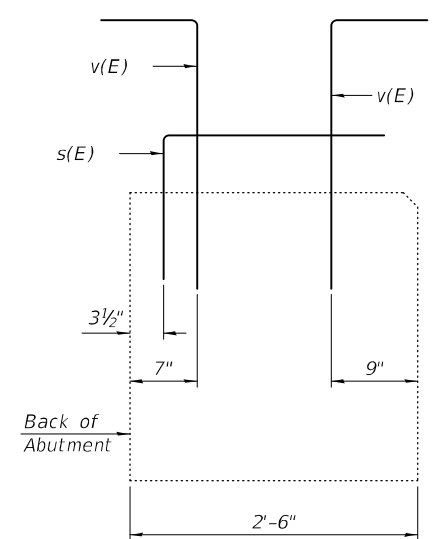

SECTION AT EAST ABUTMENT
(Horizontal dimensions are at Right L's)

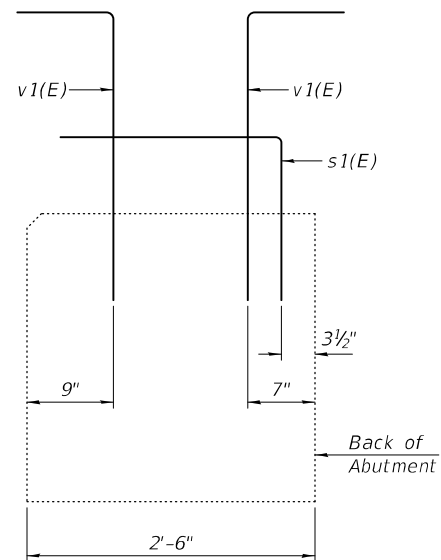

SECTION AT WEST ABUTMENT
(Horizontal dimensions are at Right L's)

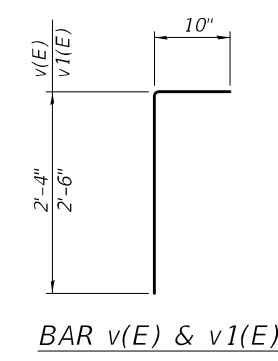

BAR v(E) & v1(E)

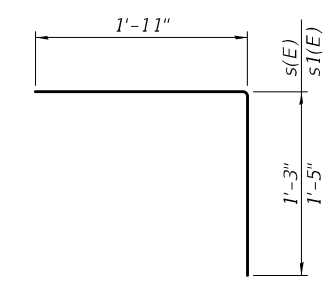

BAR s(E) & s1(E)

TWO ABUTMENTS & PIER
BILL OF MATERIAL

Bar	No.	Size	Length	Shape
v(E)	68	#5	3'-2"	┌
v1(E)	68	#5	3'-4"	┌
v2(E)	68	#5	2'-3"	┌
s(E)	34	#4	3'-2"	└
s1(E)	34	#4	3'-4"	└
Reinforcement Bars, Epoxy Coated			Pound	770

MODEL: 000000-00000-020
FILE NAME: p:\w\pwbentley.com\FWIDOT\Documents\DOT Offices\Bureau of Bridges and Structures\Projects\0960064\CADD Plans\0960064-74857.dgn
3/28/2024 9:28:24 AM

DESIGNED - ANDREW DIORIO
CHECKED - PAUL JOHNSON
DRAWN - ANDRO R. SAMANIEGO
CHECKED - A.M.D./P.S.J.

EXAMINED
PASSED
Mark Shuffler
ENGINEER OF BRIDGE DESIGN
Jayne F. [Signature]
ENGINEER OF BRIDGES AND STRUCTURES

DATE - MARCH 27, 2024
REVISED -
REVISED -

STATE OF ILLINOIS
DEPARTMENT OF TRANSPORTATION

EXISTING ABUTMENT & PIER DETAILS
STRUCTURE NO. 096-0064

SHEET 20 OF 21 SHEETS

F.A.P. RTE.	SECTION	COUNTY	TOTAL SHEETS	SHEET NO.
823	(24BR-1)BR	WAYNE	57	38
			CONTRACT NO. 74857	
		ILLINOIS FED. AID PROJECT		

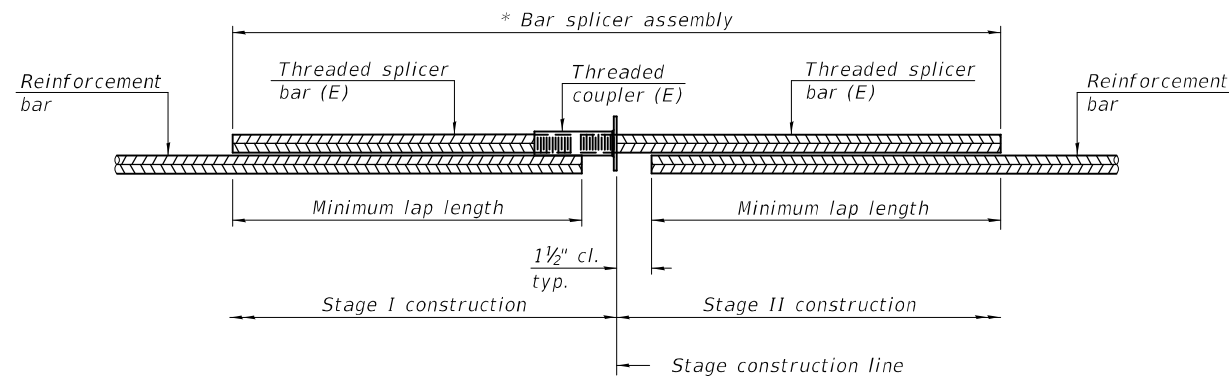

STANDARD BAR SPLICER ASSEMBLY PLAN

Only bar splicer assemblies as presented on the approved QPL list may be used.

Threaded splicer bar length = min. lap length + 1 1/2" + thread length

* Epoxy not required on Bar Splicer Assembly components used in conjunction with black bars.

Location	Bar size	No. assemblies required	Minimum lap length
Slab (Top)	#7	97	4'-8"
Slab (Bottom)	#7	116	4'-8"
Slab (Haunches)	#4	9	2'-5"
Appr. Slab (top)	#5	88	3'-4"
Appr. Slab (Bottom)	#8	116	4'-9"
Approach Footings	#5	80	3'-2"

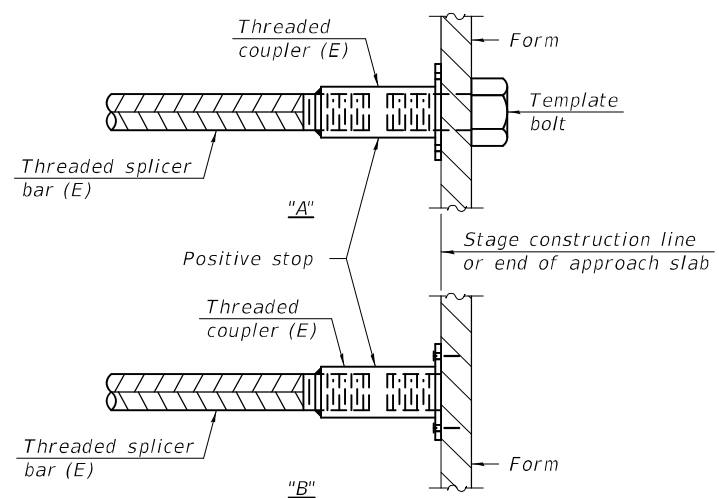

INSTALLATION AND SETTING METHODS

"A" : Set bar splicer assembly by means of a template bolt.

"B" : Set bar splicer assembly by nailing to wood forms or cementing to steel forms.

(E) : Indicates epoxy coating.

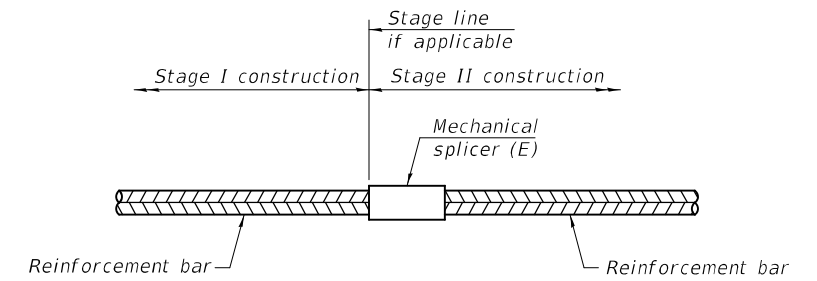

STANDARD MECHANICAL SPLICER

Location	Bar size	No. assemblies required

Notes:

Splicer bars shall be deformed with threaded ends and have a minimum 60 ksi yield strength.

All reinforcement shall be lapped and tied to the splicer bars.

Bar splicer assemblies shall be epoxy coated according to the requirements for reinforcement bars. See Section 508 of the Standard Specifications.

See approved list of bar splicer assemblies and mechanical splicers for alternatives.

MODEL: 000000-00000-021
FILE NAME: p:\w\l\p\w\benley.com\FW\DOT\Documents\DOT Offices\Bureau of Bridges and Structures\Projects\0960064\CADD Plans\0960064-74857.dgn

BSD-1

2-1-2023

DESIGNED - ANDREW DIORIO	EXAMINED	DATE - MARCH 27, 2024
CHECKED - PAUL JOHNSON	PASSED	REVISED -
DRAWN - ANDRO R. SAMANIEGO		REVISED -
CHECKED - A.M.D. / P.S.J.		

Mark Shuffin
ENGINEER OF BRIDGE DESIGN

Jaime F. ...
ENGINEER OF BRIDGES AND STRUCTURES

**STATE OF ILLINOIS
DEPARTMENT OF TRANSPORTATION**

**BAR SPLICER ASSEMBLY AND MECHANICAL SPLICER DETAILS
STRUCTURE NO. 096-0064**

F.A.P. RTE.	SECTION	COUNTY	TOTAL SHEETS	SHEET NO.
823	(24BR-1)BR	WAYNE	57	39
CONTRACT NO. 74857			ILLINOIS FED. AID PROJECT	

SHEET 21 OF 21 SHEETS

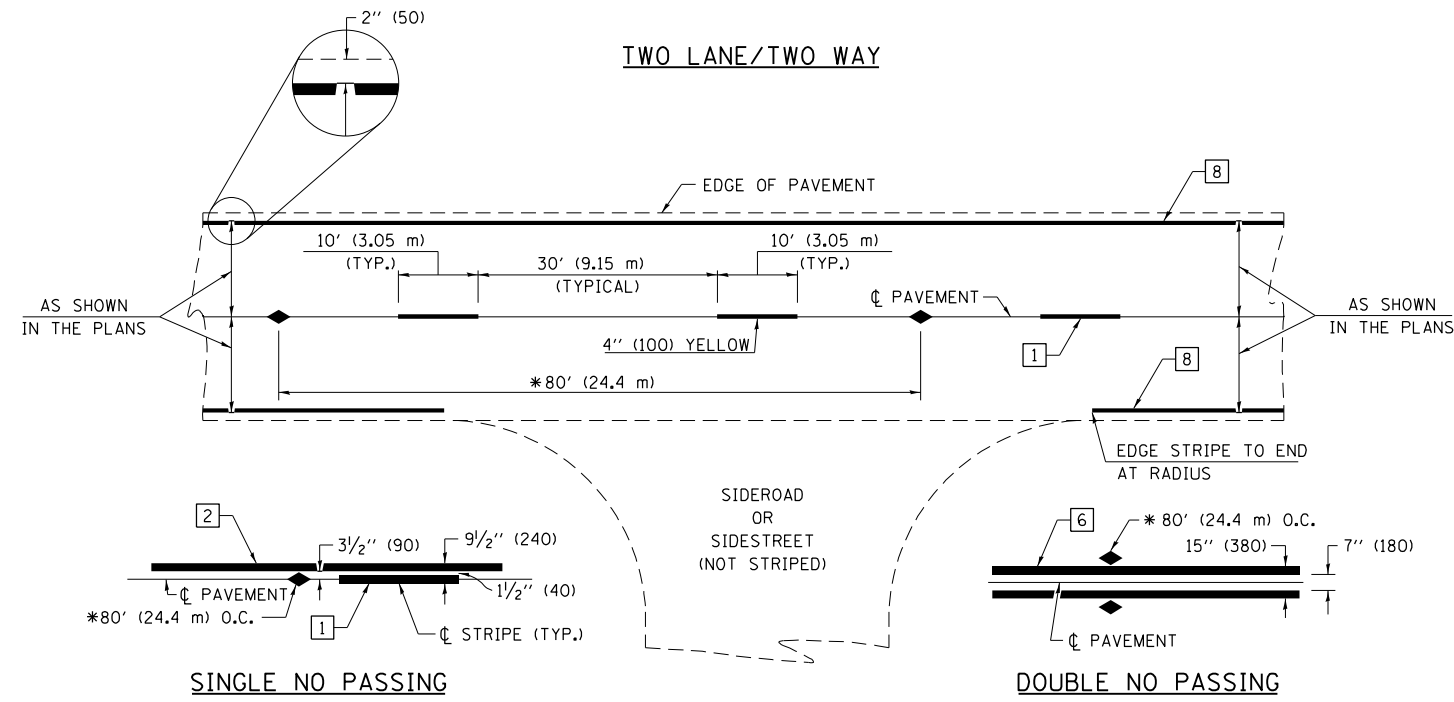

PAVEMENT MARKING LEGEND

- 1 4" (100) SKIP-DASH (YELLOW)
- 2 4" (100) SOLID (YELLOW)
- 3 12" (300) DIAGONAL (YELLOW)
- 4 4" (100) DOUBLE YELLOW (NARROW)
- 5 12" (300) SOLID WHITE
- 6 4" (100) DOUBLE YELLOW (WIDE)
- 7 6" (150) SKIP-DASH (WHITE)
- 8 4" (100) SOLID (WHITE)
- 9 12" (300) DIAGONAL (WHITE)
- 10 6" (150) SOLID (WHITE)
- 11 24" (600) STOP BAR (WHITE)
- 12 8" (200) SOLID (WHITE)
- 13 4" (100) PARKING WHITE

* REDUCE TO 40' (12.2 m) O.C. ON CURVES WITH POSTED OR ADVISORY SPEEDS OF 45 mph (70 km/h) OR LESS.

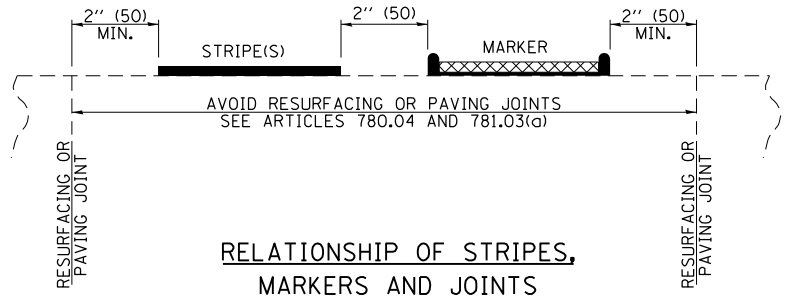

TYPICAL PAVEMENT MARKERS LEGEND

- ◆ TWO-WAY AMBER MARKER
- ▶ ONE-WAY AMBER MARKER
- ▷ ONE-WAY CRYSTAL MARKER

RAISED REFLECTIVE PAVEMENT MARKERS

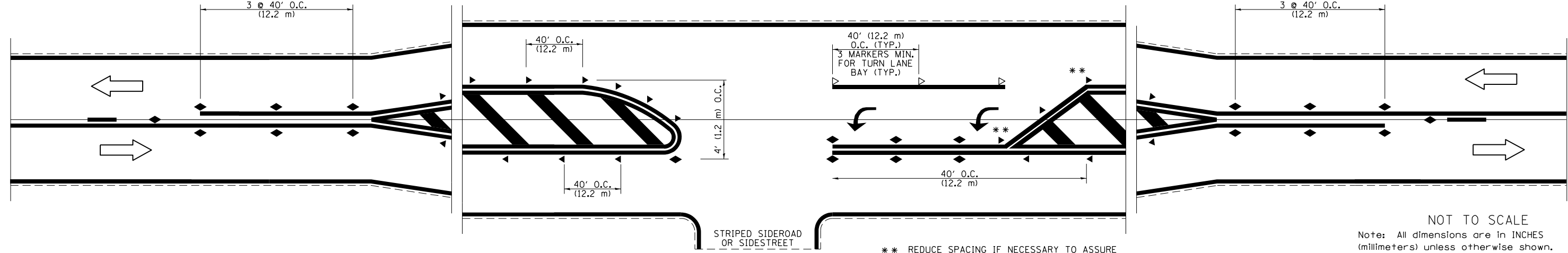

NOT TO SCALE
Note: All dimensions are in INCHES (millimeters) unless otherwise shown.

DISTRICT 7 DETAIL NO. 7800001

USER NAME = jessica.wille	DESIGNED -	REVISED - NAS 06/22
PLOT SCALE = 100,0000' / in.	DRAWN -	REVISED -
PLOT DATE = 2/1/2024	CHECKED -	REVISED -
	DATE -	REVISED -

**STATE OF ILLINOIS
DEPARTMENT OF TRANSPORTATION**

**PAVEMENT MARKING AND RAISED REFLECTIVE PAVEMENT MARKERS
(RURAL & URBAN APPLICATIONS)**

F.A.P. RTE.	SECTION	COUNTY	TOTAL SHEETS	SHEET NO.
823	(24BR-1)BR	WAYNE	57	40
CONTRACT NO. 74857				

SCALE: NO SCALE SHEET OF SHEETS STA. TO STA.

MODEL: Default FILE: \\naifc-pw-bentley.com\P\DOT\Documents\DOT Office\Director_7\Project\74857\CADD\Drawings\Drawings\74857-48-01.dwg

URBAN LEFT TURN

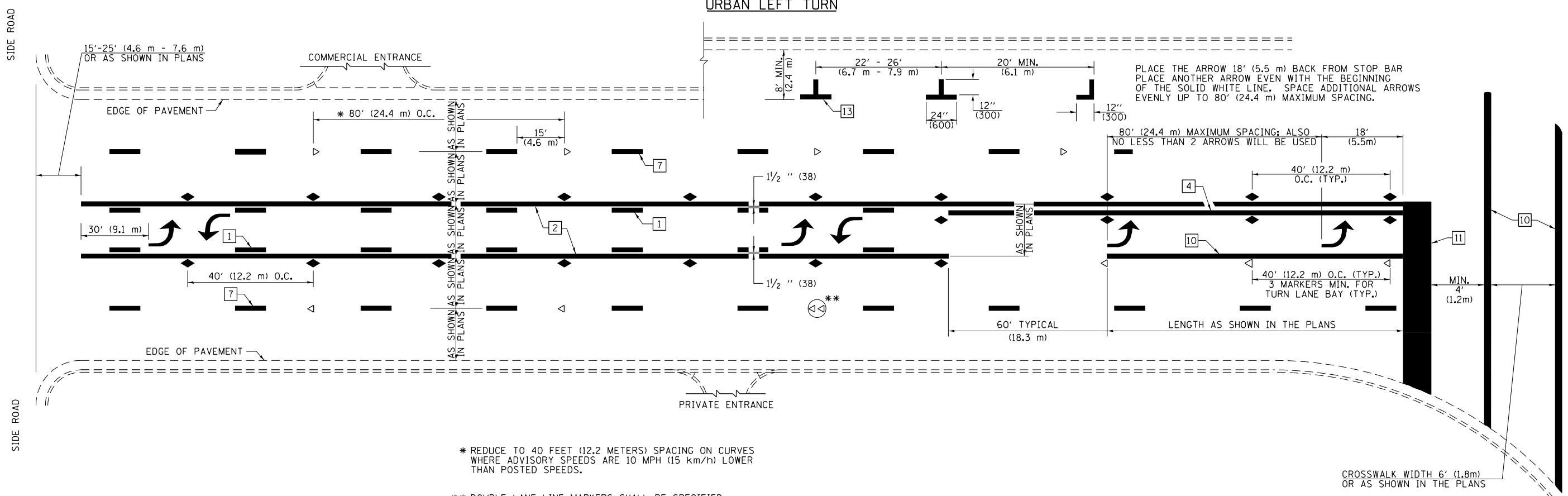

* REDUCE TO 40 FEET (12.2 METERS) SPACING ON CURVES WHERE ADVISORY SPEEDS ARE 10 MPH (15 km/h) LOWER THAN POSTED SPEEDS.

** DOUBLE LANE LINE MARKERS SHALL BE SPECIFIED AND SPACED AS SHOWN IN HIGHWAY STANDARD 781001 FOR MULTI-LANE DIVIDED AND UNDIVIDED HIGHWAYS.

PAVEMENT MARKING LEGEND

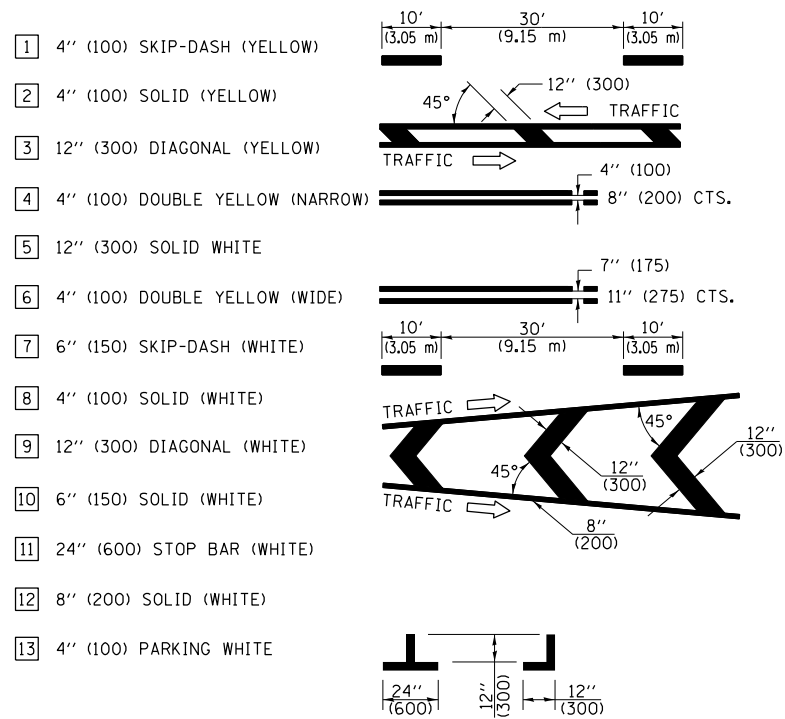

GENERAL NOTES

- TURN ARROW PAIRS SHALL BE PLACED AT 250' (75 m) INTERVALS AND SHALL BE EVENLY SPACED BETWEEN BOTH ENDS OF THE BIDIRECTIONAL LEFT TURN LANE. USE A MINIMUM OF TWO PAIRS PER BLOCK.
- THE SOLID YELLOW PAVEMENT MARKINGS [2] SHOULD GENERALLY START OR END NEAR THE RADIUS POINT OF EACH STREET RETURN EXCEPT WHERE ONE OR BOTH ENDS WOULD INCLUDE STOP BARS.
- THE SKIP-DASH PAVEMENT MARKINGS [1] OR [7] SHOULD BE CENTERED BETWEEN BOTH ENDS OF EACH CITY BLOCK AND SHALL BE PLACED SO THEY LINE UP ACROSS FROM EACH OTHER.
- USE LARGE ARROW SIZE FOR BOTH RURAL AND URBAN LOCATIONS. (SEE SECTION 780 FOR SYMBOLS TABLE)
- LANE LINE EXTENSIONS SHALL BE THE SAME COLOR AND WIDTH AS THE LANE LINE BEING EXTENDED.
- ALL WHITE SKIP-DASH LINES SHALL BE 6" IN WIDTH.

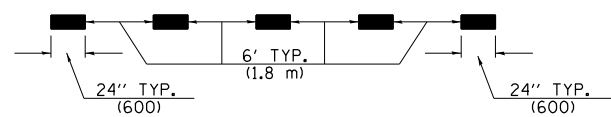

LANE LINE EXTENSIONS

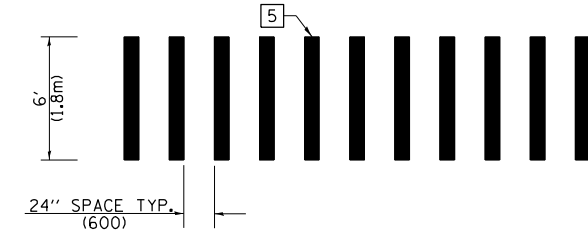

CROSSWALK DETAIL (DECATUR CITY LIMITS ONLY)

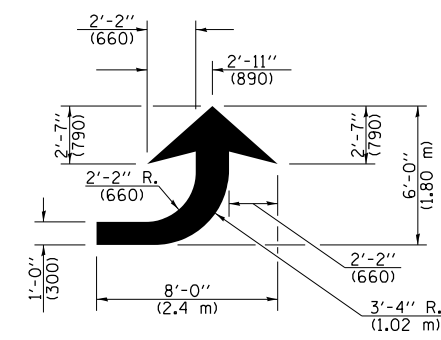

LEFT ARROW

REVERSE FOR RIGHT ARROW
AREA = 15.6 SQ. FT. (1.47 m²)
(WHITE)

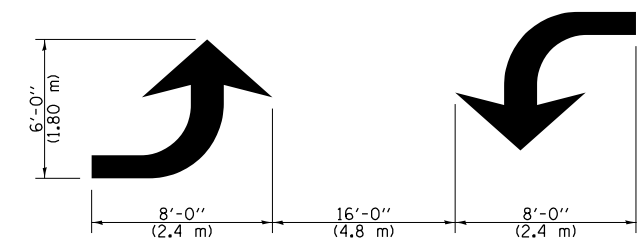

TYPICAL DOUBLE TURN ARROWS (WHITE)

NOT TO SCALE

Note: All dimensions are in INCHES (millimeters) unless otherwise shown.

DISTRICT 7 DETAIL NO. 7800001

USER NAME = jessica.wille	DESIGNED -	REVISED - NAS 06/22
PLOT SCALE = 100,0000' / 1in.	DRAWN -	REVISED -
PLOT DATE = 2/1/2024	CHECKED -	REVISED -
	DATE -	REVISED -

**STATE OF ILLINOIS
DEPARTMENT OF TRANSPORTATION**

**PAVEMENT MARKING AND RAISED REFLECTIVE PAVEMENT MARKERS
(RURAL & URBAN APPLICATIONS)**

SCALE: NO SCALE SHEET OF SHEETS STA. TO STA.

F.A.P. RTE.	SECTION	COUNTY	TOTAL SHEETS	SHEET NO.
823	(24BR-1)BR	WAYNE	57	41
CONTRACT NO. 74857				
ILLINOIS FED. AID PROJECT				

MODEL: Default
 FILE: 3dmarkup_pavement.pwd
 PROJECT: 74857\Documents\DOT Office\Director_7\Project\74857\CADD\Drawings\Drawings\74857-11-detailed.dwg
 PLOT DATE: 2/1/2024

ISLANDS

OPTION 1

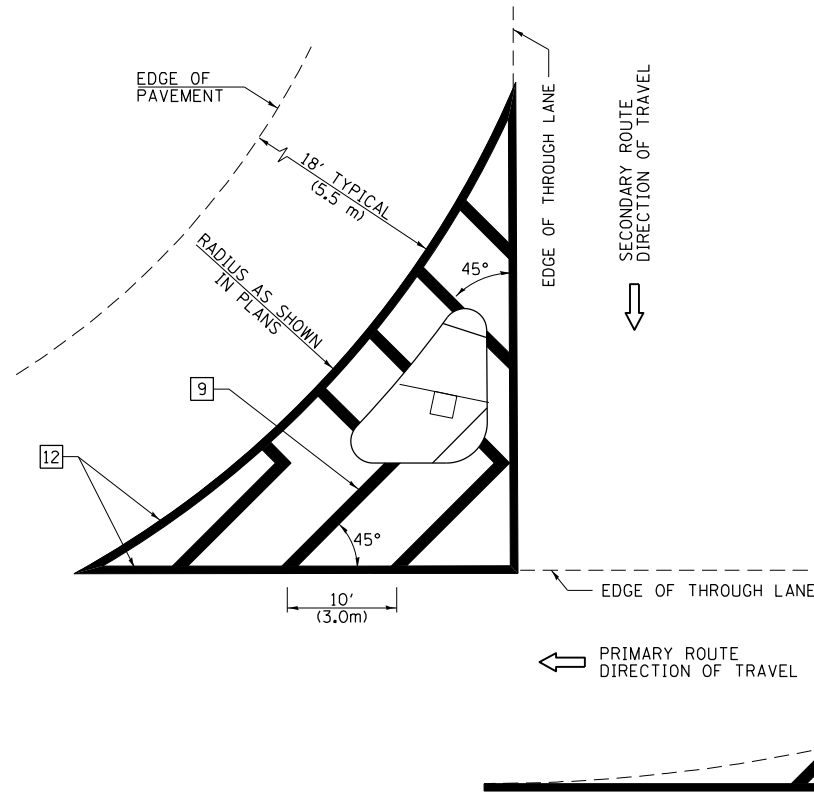

GENERAL NOTES

1. RAISED AND CORRUGATED MEDIANS SHALL BE OUTLINED WITH [2].
2. SOME OF THE INFORMATION INCLUDED WITH THIS DETAIL MAY NOT BE APPLICABLE TO THIS IMPROVEMENT.
3. PAVEMENT MARKINGS ARE TO BE EXTENDED THROUGH OMISSIONS WHEN APPLICABLE.
4. FINAL PAVEMENT MARKINGS SHALL BE IN PLACE PRIOR TO PLACING ANY RAISED REFLECTIVE PAVEMENT MARKERS.
5. THE FOLLOWING CRITERIA SHALL BE USED FOR SELECTING THE DIAGONAL PAVEMENT MARKING SPACING:

< 30 MPH (< 50 km/h)	15' (4.5 m)
30-45 MPH (50-75 km/h)	20' (6.0 m)
> 45 MPH (> 75 km/h)	30' (9.0 m)
6. THE USE OF ISLAND STRIPING OPTION 1 OR OPTION 2 SHALL BE AS SHOWN ON THE PLANS.

OPTION 2

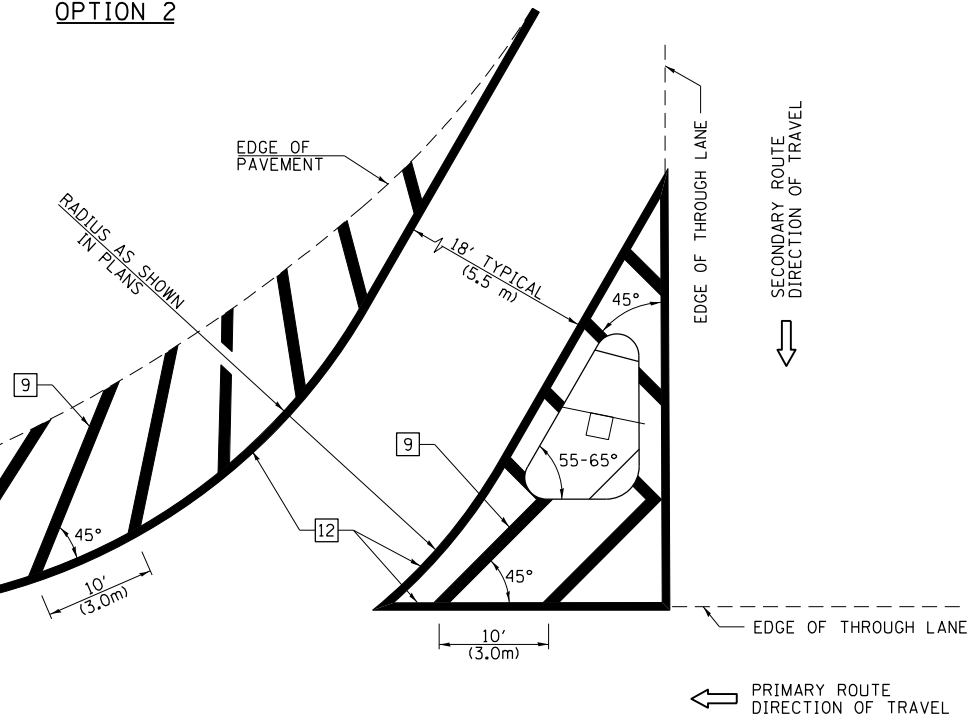

PAVEMENT MARKING LEGEND

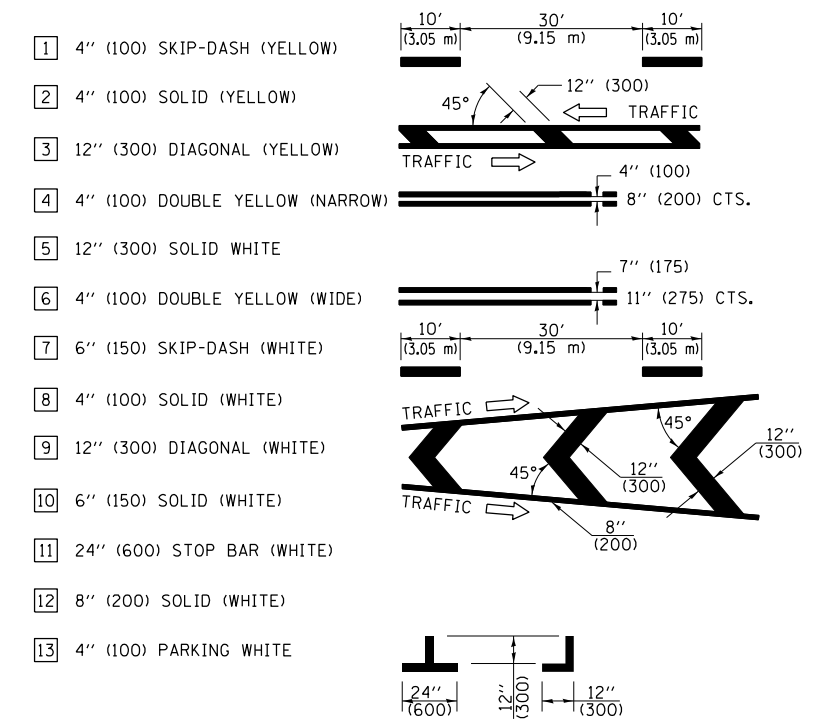

RURAL LEFT TURN STRIPING

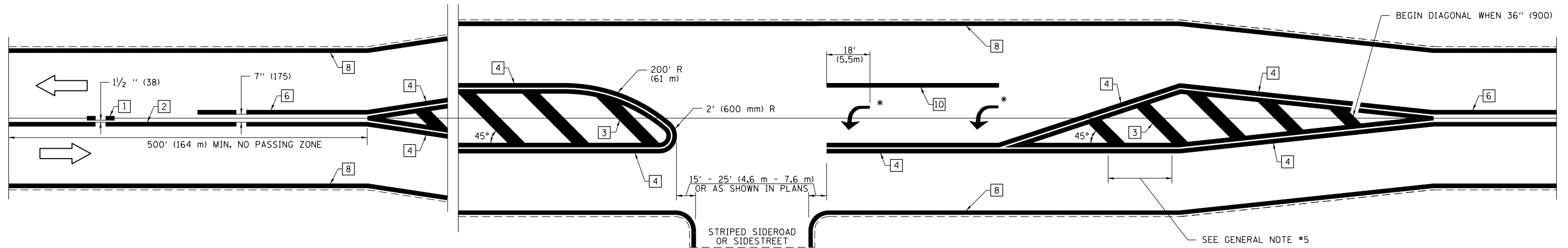

* PLACE AN ARROW 18' (5.5 m) BACK FROM END OF THE SOLID WHITE LINE. PLACE ANOTHER ARROW EVEN WITH THE BEGINNING OF THE SOLID WHITE LINE. SPACE ADDITIONAL ARROWS EVENLY UP TO 80' (24.4 m) MAXIMUM SPACING. USE MINIMUM OF 2 ARROWS.

NOT TO SCALE

Note: All dimensions are in INCHES (millimeters) unless otherwise shown.

DISTRICT 7 DETAIL NO. 7800001

USER NAME = jessica.ville	DESIGNED -	REVISOR - NAS	DATE - 06/22
PLOT SCALE = 100,0000' / in.	DRAWN -	REVISOR -	DATE -
PLOT DATE = 2/1/2024	CHECKED -	REVISOR -	DATE -
	DATE -	REVISOR -	DATE -

**STATE OF ILLINOIS
DEPARTMENT OF TRANSPORTATION**

**PAVEMENT MARKING AND RAISED REFLECTIVE PAVEMENT MARKERS
(RURAL & URBAN APPLICATIONS)**

SCALE: NO SCALE SHEET OF SHEETS STA. TO STA.

F.A.P. RTE.	SECTION	COUNTY	TOTAL SHEETS	SHEET NO.
823	(24BR-1)BR	WAYNE	57	42
CONTRACT NO. 74857				
ILLINOIS FED. AID PROJECT				

SUPPLEMENTAL PAVEMENT MARKING TREATMENT FOR RAILROAD-HIGHWAY GRADE CROSSING

PAVEMENT MARKING LEGEND

- 1 4" (100) SKIP-DASH (YELLOW)
 - 2 4" (100) SOLID (YELLOW)
 - 3 12" (300) DIAGONAL (YELLOW)
 - 4 4" (100) DOUBLE YELLOW (NARROW)
 - 5 12" (300) SOLID WHITE
 - 6 4" (100) DOUBLE YELLOW (WIDE)
 - 7 6" (150) SKIP-DASH (WHITE)
 - 8 4" (100) SOLID (WHITE)
 - 9 12" (300) DIAGONAL (WHITE)
 - 10 6" (150) SOLID (WHITE)
 - 11 24" (600) STOP BAR (WHITE)
 - 12 8" (200) SOLID (WHITE)
 - 13 4" (100) PARKING WHITE
-

PAVEMENT MARKINGS AT RAILROAD-HIGHWAY GRADE CROSSING

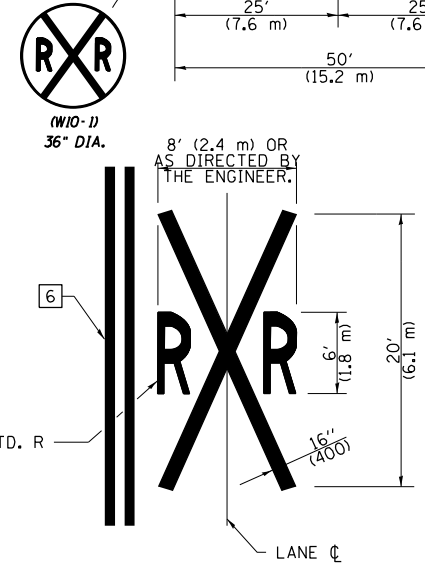
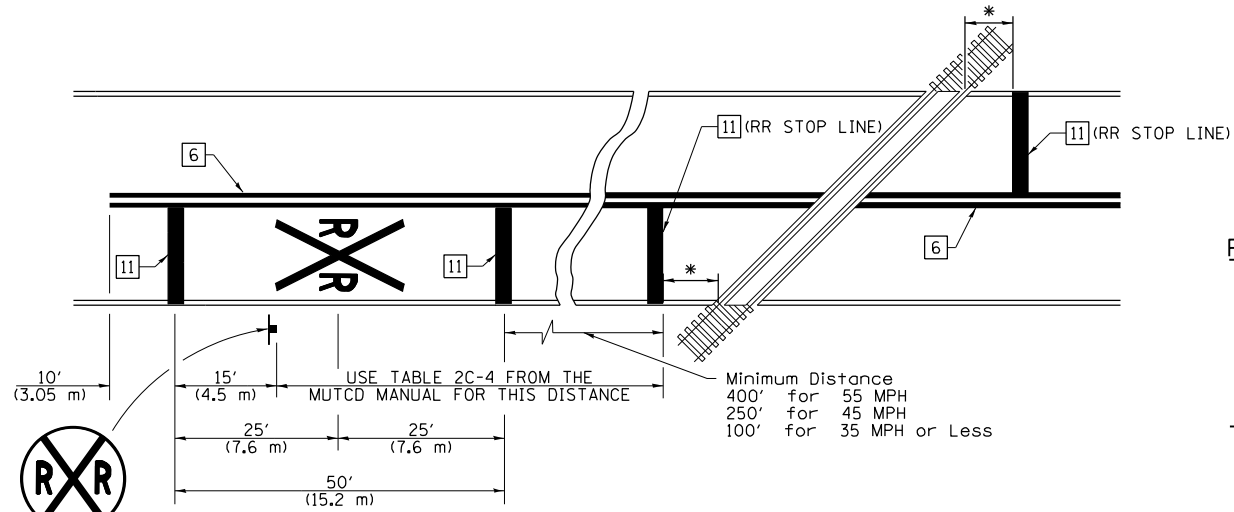

NOTES

THE TRAVERSE SPREAD OF THE "X" MAY VARY ACCORDING TO LANE WIDTH.

ON MULTI-LANE ROADS, THE STOP LINES SHALL EXTEND ACROSS ALL APPROACH LANES AND SEPARATE RRR SYMBOLS SHALL BE PLACED ADJACENT TO EACH OTHER IN EACH LANE.

WHEN THE PAVEMENT MARKING SYMBOL IS USED, A PORTION OF THE SYMBOL SHOULD BE LOCATED DIRECTLY ADJACENT TO THE ADVANCE WARNING SIGN (W10-1) AS PLACED BY TABLE II-1, CONDITION B OF THE MUTCD.

RAILROAD CROSSING WITH NON-SIGNALIZED INTERSECTION

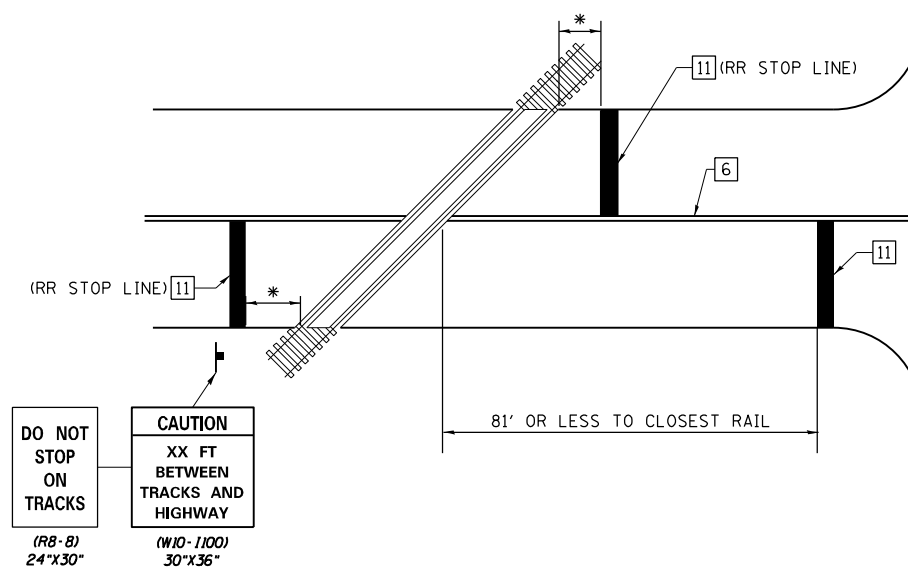

RAILROAD CROSSING WITH INTERCONNECT AND PRE-SIGNALS

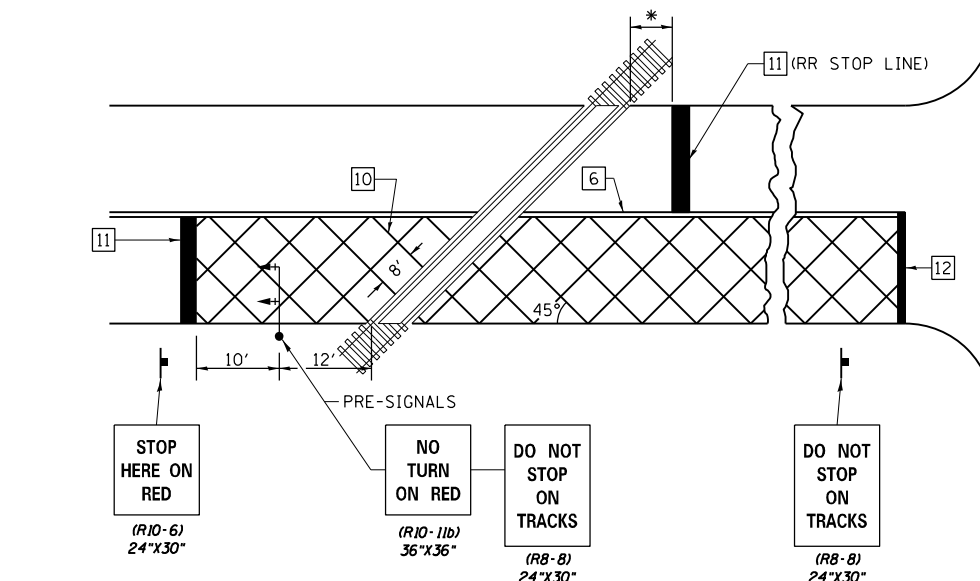

RAILROAD CROSSING WITH INTERCONNECT ONLY

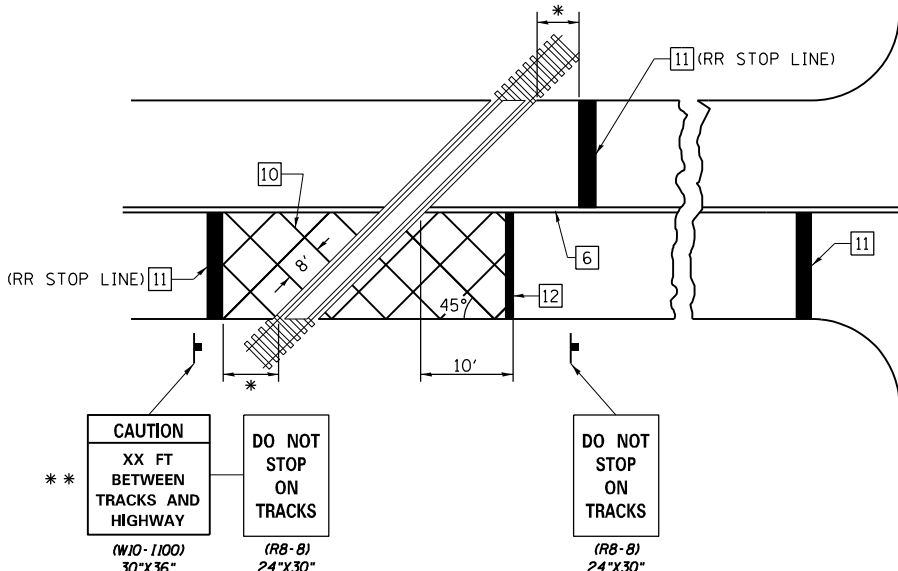

GENERAL NOTES

- SUPPLEMENTAL PAVEMENT MARKINGS TO BE INSTALLED ONLY ON APPROACHES TO INTERSECTIONS CONTROLLED BY TRAFFIC SIGNALS WHICH ARE INTERCONNECTED WITH THE RAILROAD WARNING SIGNALS.
- EXTEND PAVEMENT MARKINGS TO THE INTERSECTION ONLY WHERE PRE-SIGNALS ARE USED.
- WHEN PEDESTRIAN SIGNALS ARE PRESENT WITH INTERCONNECTED SIGNALS, WARNING SIGN W10-1101 (18"X24") SHALL BE PLACED NEAR EACH PEDESTRIAN SIGNAL HEAD. COUNTDOWN PEDESTRIAN SIGNAL HEADS SHALL NOT BE UTILIZED ALONG WITH INTERCONNECTED SIGNALS.
- PLEASE REFER TO THE IDOT BUREAU OF OPERATION MEMO OPS T-06 DATED DECEMBER 1, 2020 FOR ADDITIONAL INFORMATION.

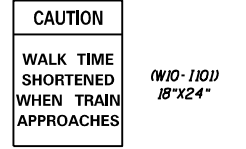

- * 15' FROM NEAR RAIL OR 8' FROM AND PARALLEL TO GATE IF PRESENT
- ** WARNING SIGN W10-1100 SHALL BE USED AS AN INTERIM MEASURE AT INTERCONNECTED SIGNAL LOCATIONS WHERE PRE-SIGNALS ARE TO BE INSTALLED IN THE FUTURE. THIS SIGN SHALL BE REMOVED WHEN THE PRE-SIGNALS ARE INSTALLED AND THE PAVEMENT MARKINGS ARE EXTENDED TO THE INTERSECTION.

NOT TO SCALE
Note: All dimensions are in INCHES (millimeters) unless otherwise shown.

DISTRICT 7 DETAIL NO. 7800001

USER NAME = jessica.hille	DESIGNED -	REVISED - NAS 06/22
PLOT SCALE = 100,0000' / in.	DRAWN -	REVISED -
PLOT DATE = 2/1/2024	CHECKED -	REVISED -
	DATE -	REVISED -

STATE OF ILLINOIS
DEPARTMENT OF TRANSPORTATION

PAVEMENT MARKING AND RAISED REFLECTIVE PAVEMENT MARKERS
(RURAL & URBAN APPLICATIONS)

F.A.P. RTE.	SECTION	COUNTY	TOTAL SHEETS	SHEET NO.
823	(24BR-1)BR	WAYNE	57	43
CONTRACT NO. 74857				

SCALE: NO SCALE SHEET OF SHEETS STA. TO STA.

ILLINOIS FED. AID PROJECT

MODEL: Default FILE: Mainfile: p:\idistrict-pw-beadefy.com\FWIDOT\Documents\1100T_Offices\Director_7\Project\74857\CADD\Drawings\Sheet\0774857-rh-detail.dwg

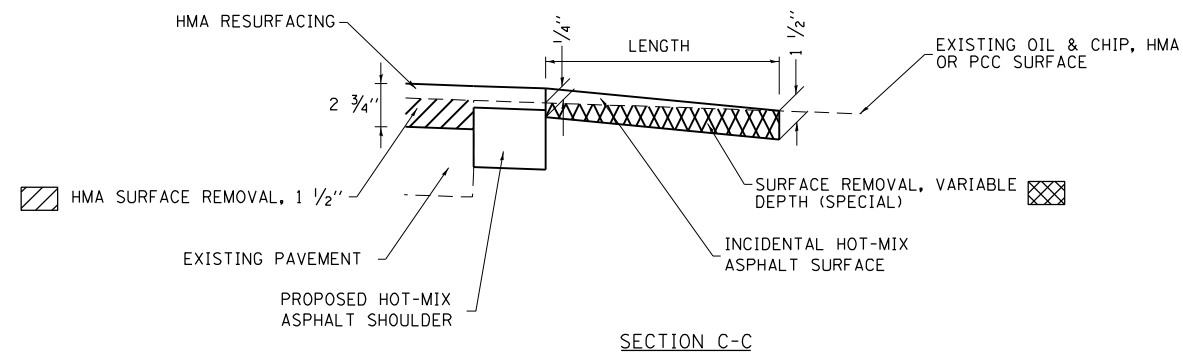
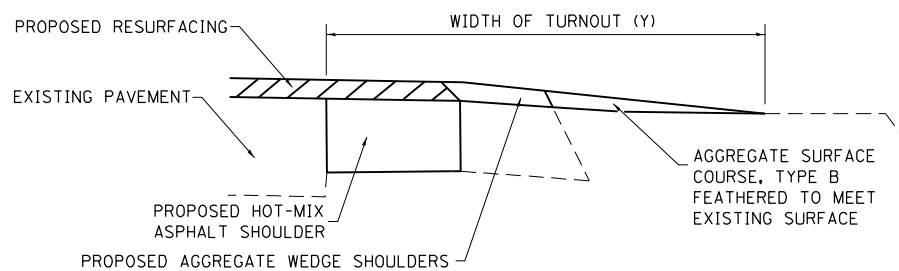
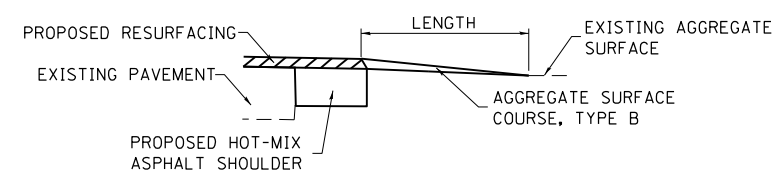
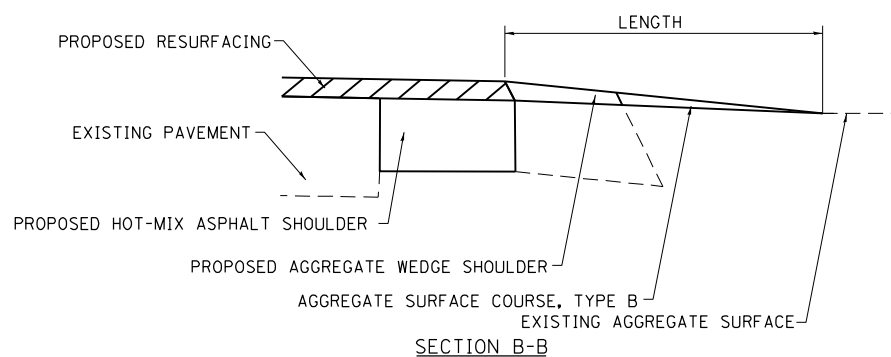
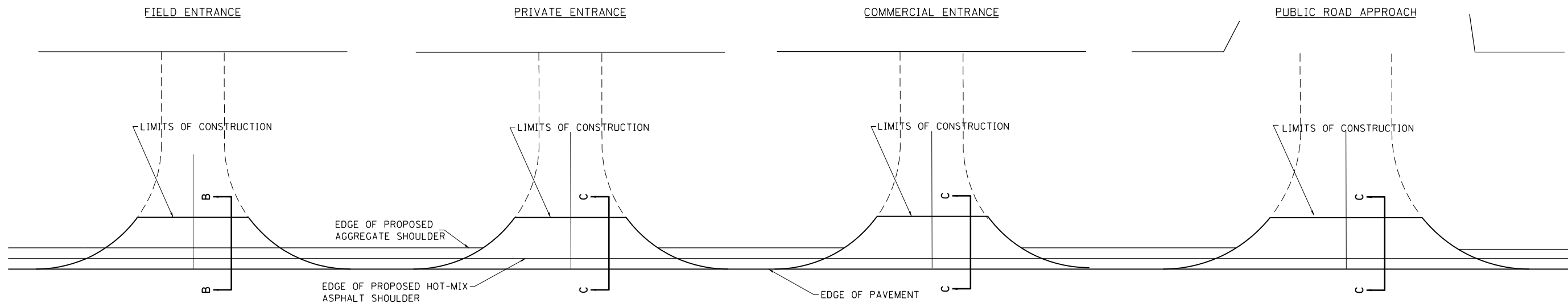

TYPICAL SECTION AT MAILBOX TURNOUT
NOTE: SEE STANDARD 406201 FOR MAILBOX TURNOUT DETAILS

NOTES

LENGTH = 10' UNLESS OTHERWISE NOTED ON PLANS

THE THICKNESS OF THE HOT-MIX ASPHALT SHOULDERS THROUGH AGGREGATE COMMERCIAL ENTRANCES AND PUBLIC ROADS SHALL BE 10". THE COST OF THE EXTRA THICKNESS SHALL BE INCLUDED WITH THE HOT-MIX ASPHALT SHOULDERS PAY ITEM.

MODEL: Default
FILE: Mailbox_Turnout_Spec.dwg
PROJECT: 24BR-1)BR
SHEET: 44
DATE: 2/1/2024

USER NAME = jessica.hille	DESIGNED -	REVISED -
PLOT SCALE = 100,0000' / in.	DRAWN -	REVISED -
PLOT DATE = 2/1/2024	CHECKED -	REVISED -
	DATE -	REVISED -

**STATE OF ILLINOIS
DEPARTMENT OF TRANSPORTATION**

**RURAL ENTRANCE AND MAILBOX TURNOUT DETAILS
SHOULDER (PROPOSED)**

SCALE: NO SCALE SHEET OF SHEETS STA. TO STA.

F.A.P. RTE. 823	SECTION (24BR-1)BR	COUNTY WAYNE	TOTAL SHEETS 57	SHEET NO. 44
ILLINOIS FED. AID PROJECT			CONTRACT NO. 74857	

FINAL SURVEY NO.	SURVEYED	DATE
NOTE BOOK NO.	PLOTTED	
	TEMPLATE	
	AREAS CHECKED	

ORIGINAL SURVEY NO.	SURVEYED	DATE
	PLOTTED	
	TEMPLATE	
	AREAS CHECKED	

MODEL: Definit
 FILE NAME: D:\Illinois\paw\kennedy.com\PROJECTS\7485\CAD\Drawings\CAD\Drawings\7485-5810-000.dwg
 PROJECT: 7485
 USER: jessica.ville

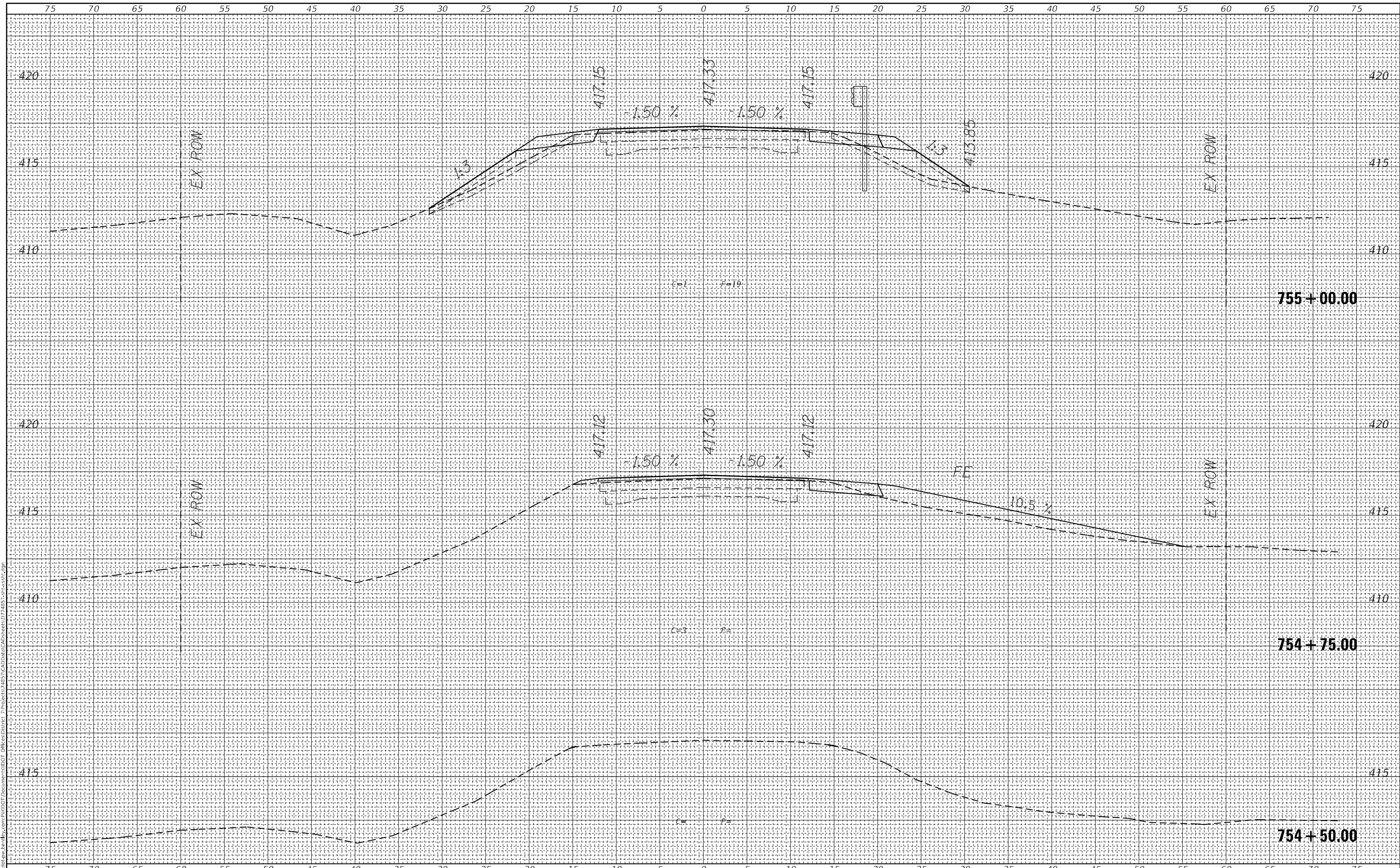

USER NAME = jessica.ville	DESIGNED - BLL	REVISED -
	DRAWN - BLL	REVISED -
PLOT SCALE = 10,0000' / in.	CHECKED -	REVISED -
PLOT DATE = 2/1/2024	DATE - 2/1/2024	REVISED -

**STATE OF ILLINOIS
 DEPARTMENT OF TRANSPORTATION**

CROSS SECTIONS

SCALE: 10,0000' / in. SHEET OF SHEETS STA. 754+50.00 TO STA. 755+00.00

F.A.P. RTE.	SECTION	COUNTY	TOTAL SHEETS	SHEET NO.
823	(24 BR-1) BR	WAYNE	57	45
CONTRACT NO. 74857				
ILLINOIS FED. AID PROJECT				

FINAL SURVEY NO.	SURVEYED	DATE
NOTE BOOK NO.	PLOTTED	
	TEMPLATE	
	AREAS CHECKED	

ORIGINAL SURVEY NO.	SURVEYED	DATE
	PLOTTED	
	TEMPLATE	
	AREAS CHECKED	

MODEL: Default
FILE NAME: D:\work\paw\kennedy.com\PROJECTS\DOT\Documents\DOT\Projects\7485\CAD\Drawings\CAD\Drawings\7485-58-0000.dwg

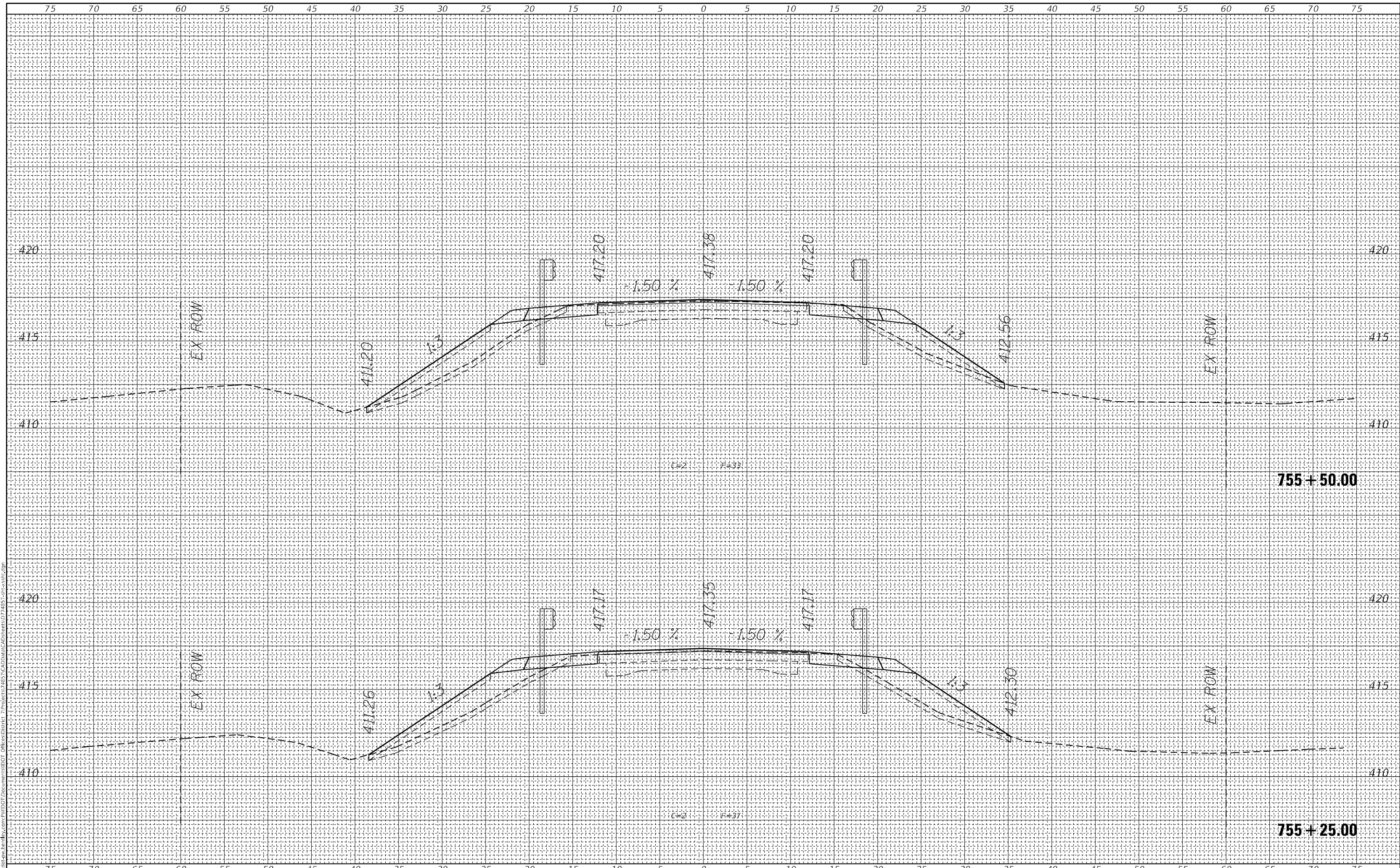

USER NAME = jessica.ville	DESIGNED - BLL	REVISED -
	DRAWN - BLL	REVISED -
PLOT SCALE = 10,000' / in.	CHECKED -	REVISED -
PLOT DATE = 2/1/2024	DATE - 2/1/2024	REVISED -

**STATE OF ILLINOIS
DEPARTMENT OF TRANSPORTATION**

CROSS SECTIONS

SCALE: 10,000' / in. SHEET OF SHEETS STA. 755+25.00 TO STA. 755+50.00

F.A.P. RTE. 823	SECTION (24 BR-1) BR	COUNTY WAYNE	TOTAL SHEETS 57	SHEET NO. 46
			CONTRACT NO. 74857	
ILLINOIS FED. AID PROJECT				

FINAL SURVEY NO.	SURVEYED	DATE
NOTE BOOK NO.	PLOTTED	
	TEMPLATE	
	AREAS CHECKED	

ORIGINAL SURVEY NO.	SURVEYED	DATE
	PLOTTED	
	TEMPLATE	
	AREAS CHECKED	

MODEL: Definit
 FILE NAME: D:\Illinois\paw\kennedy.com\PROJECTS\74857\CAD\Drawings\CAD\Drawings\74857-58\cross1.dwg

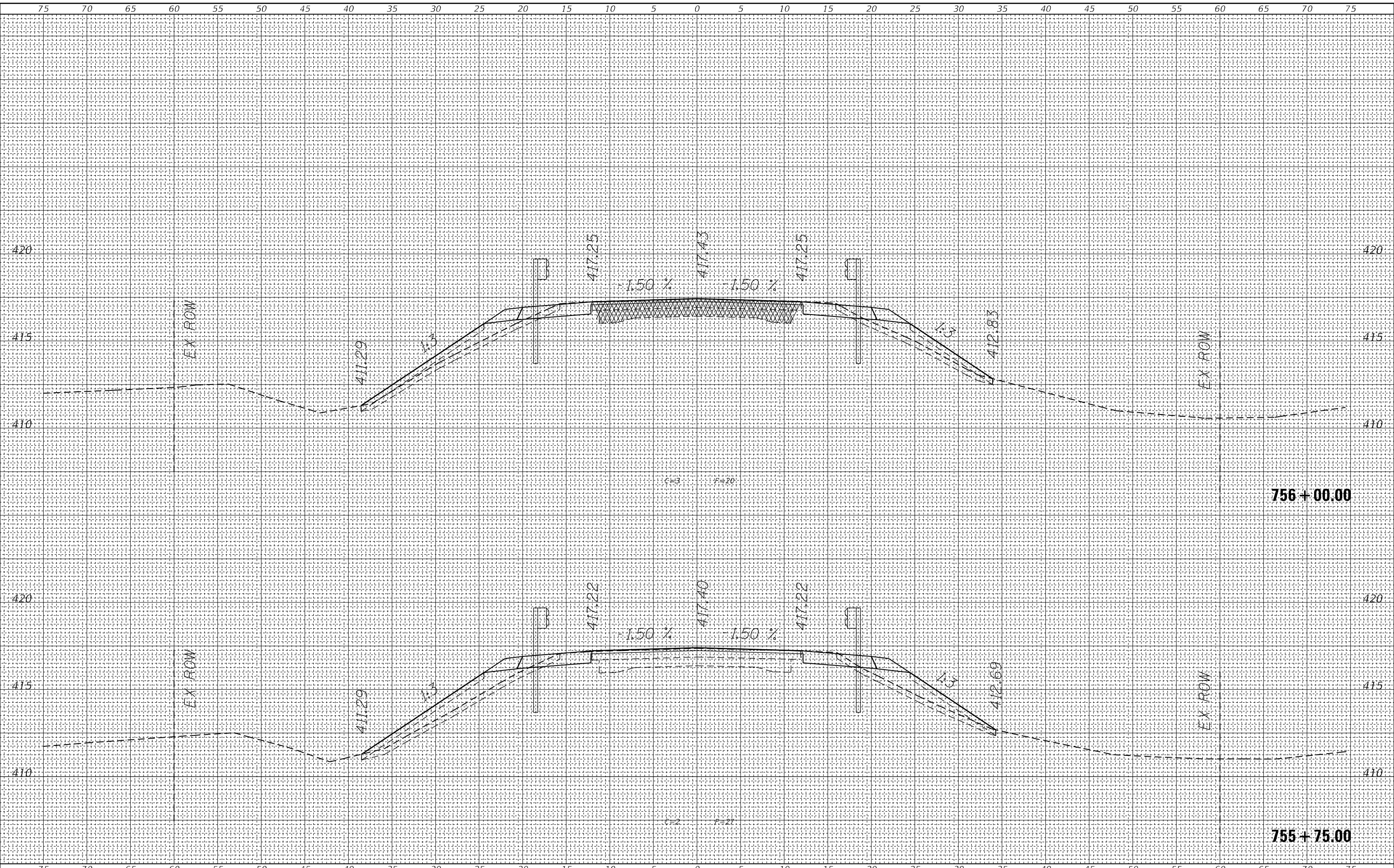

USER NAME = jessica.ville	DESIGNED - BLL	REVISED -
	DRAWN - BLL	REVISED -
PLOT SCALE = 10,000' / in.	CHECKED -	REVISED -
PLOT DATE = 2/1/2024	DATE - 2/1/2024	REVISED -

**STATE OF ILLINOIS
 DEPARTMENT OF TRANSPORTATION**

CROSS SECTIONS

SCALE: 10,000' / in. SHEET OF SHEETS STA. 755+75.00 TO STA. 756+00.00

F.A.P. RTE.	SECTION	COUNTY	TOTAL SHEETS	SHEET NO.
823	(24 BR-1) BR	WAYNE	57	47
CONTRACT NO. 74857				
ILLINOIS FED. AID PROJECT				

FINAL SURVEY NO.	SURVEYED	DATE
NOTE BOOK	PLOTTED	
AREAS CHECKED	TEMPLATE	
	AREAS CHECKED	

ORIGINAL SURVEY NO.	SURVEYED	DATE
NOTE BOOK	PLOTTED	
AREAS CHECKED	TEMPLATE	
	AREAS CHECKED	

MODEL: Definit
 FILE NAME: D:\w\illinois\paw\kennedy\com\p\w\DOT\Documents\DOT Office\Bentley\Project\74857\CAD\Draw\CAD\Draw\074857-58.dwg

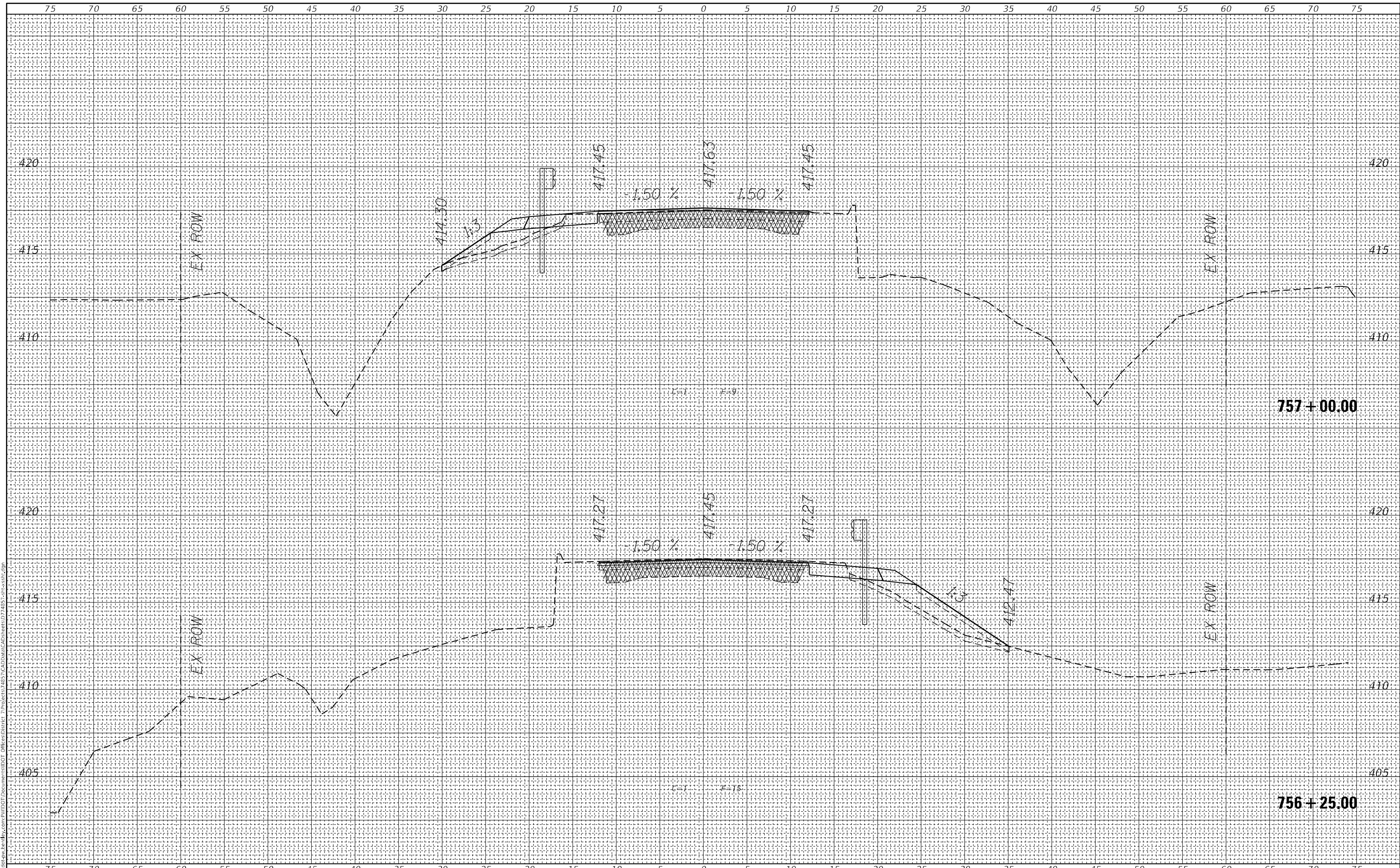

USER NAME = jessica.ville	DESIGNED - BLL	REVISED -
	DRAWN - BLL	REVISED -
PLOT SCALE = 10,0000 ' / in.	CHECKED -	REVISED -
PLOT DATE = 2/1/2024	DATE - 2/1/2024	REVISED -

**STATE OF ILLINOIS
 DEPARTMENT OF TRANSPORTATION**

CROSS SECTIONS

SCALE: 10,0000 ' / in. SHEET OF SHEETS STA. 756+25.00 TO STA. 757+00.00

F.A.P. RTE.	SECTION	COUNTY	TOTAL SHEETS	SHEET NO.
823	(24 BR-1) BR	WAYNE	57	48
CONTRACT NO. 74857				
ILLINOIS FED. AID PROJECT				

FINAL SURVEY NO.	SURVEYED	BY	DATE
NOTE BOOK	PLOTTED		
AREAS CHECKED	TEMPLATE		
	AREAS CHECKED		

ORIGINAL SURVEY NO.	SURVEYED	BY	DATE
NOTE BOOK	PLOTTED		
AREAS CHECKED	TEMPLATE		
	AREAS CHECKED		

MODEL: Definit
 FILE NAME: D:\work\paw\kennedy.com\PROJECTS\74857\CAD\Drawings\CAD\Drawings\74857-25-10-24.dwg
 PROJECT: 74857 CAD\Drawings\CAD\Drawings\74857-25-10-24.dwg

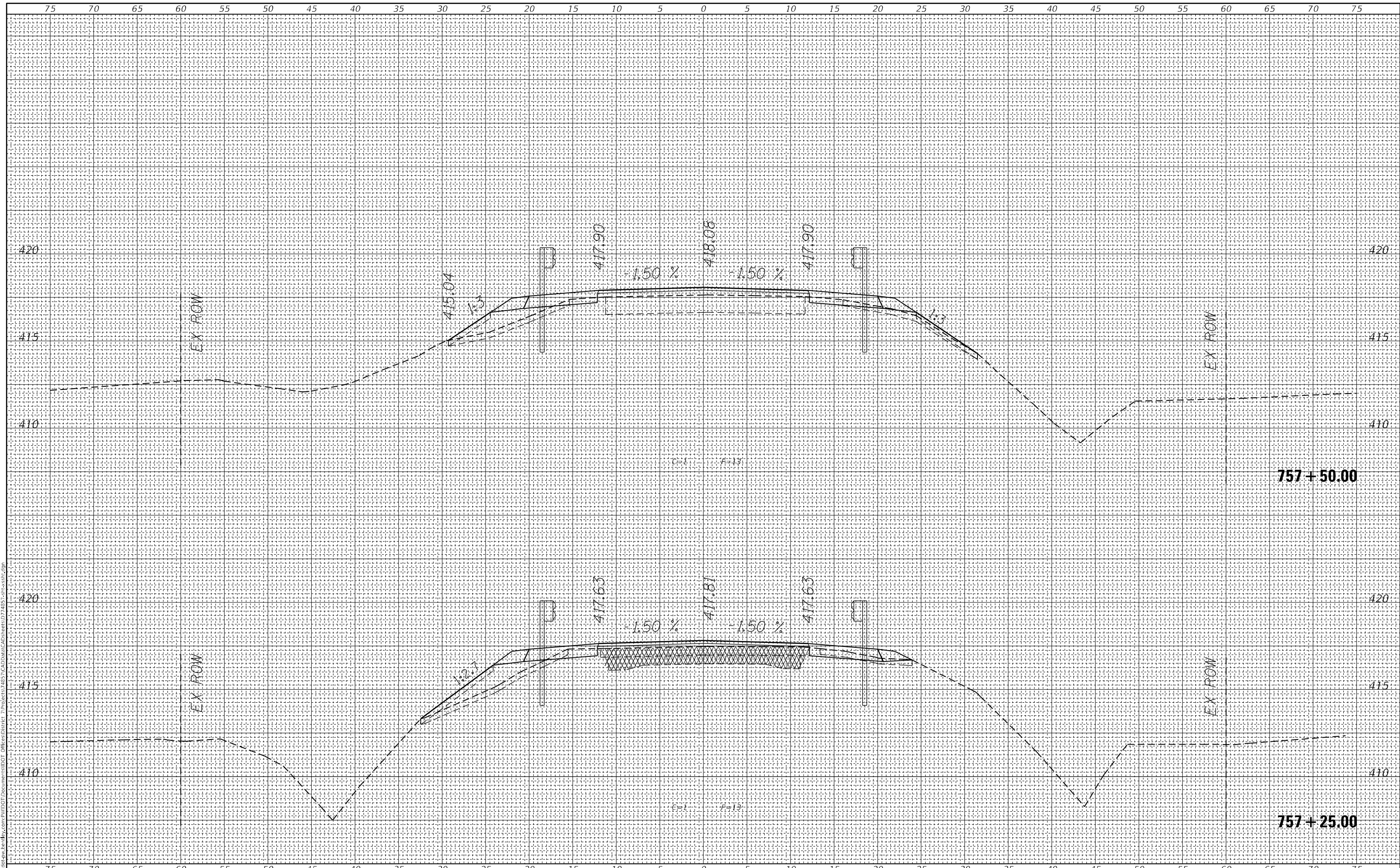

USER NAME = jessica.ville	DESIGNED - BLL	REVISED -
	DRAWN - BLL	REVISED -
PLOT SCALE = 10,0000 ' / in.	CHECKED -	REVISED -
PLOT DATE = 2/1/2024	DATE - 2/1/2024	REVISED -

**STATE OF ILLINOIS
 DEPARTMENT OF TRANSPORTATION**

CROSS SECTIONS

SCALE: 10,0000 ' / in. SHEET OF SHEETS STA. 757+25.00 TO STA. 757+50.00

F.A.P. RTE.	SECTION	COUNTY	TOTAL SHEETS	SHEET NO.
823	(24 BR-1) BR	WAYNE	57	49
				CONTRACT NO. 74857
				ILLINOIS FED. AID PROJECT

FINAL SURVEY NO.	SURVEYED	BY	DATE
NOTE BOOK NO.	PLOTTED		
	TEMPLATE		
	AREAS CHECKED		

ORIGINAL SURVEY NO.	SURVEYED	BY	DATE
	PLOTTED		
	TEMPLATE		
	AREAS CHECKED		

MODEL: Definit
 FILE NAME: D:\w\illinois\paw\kennedy.com\PROJECTS\74857\CAD\DATA\CAD\BR-1\74857-58-58585.dgn

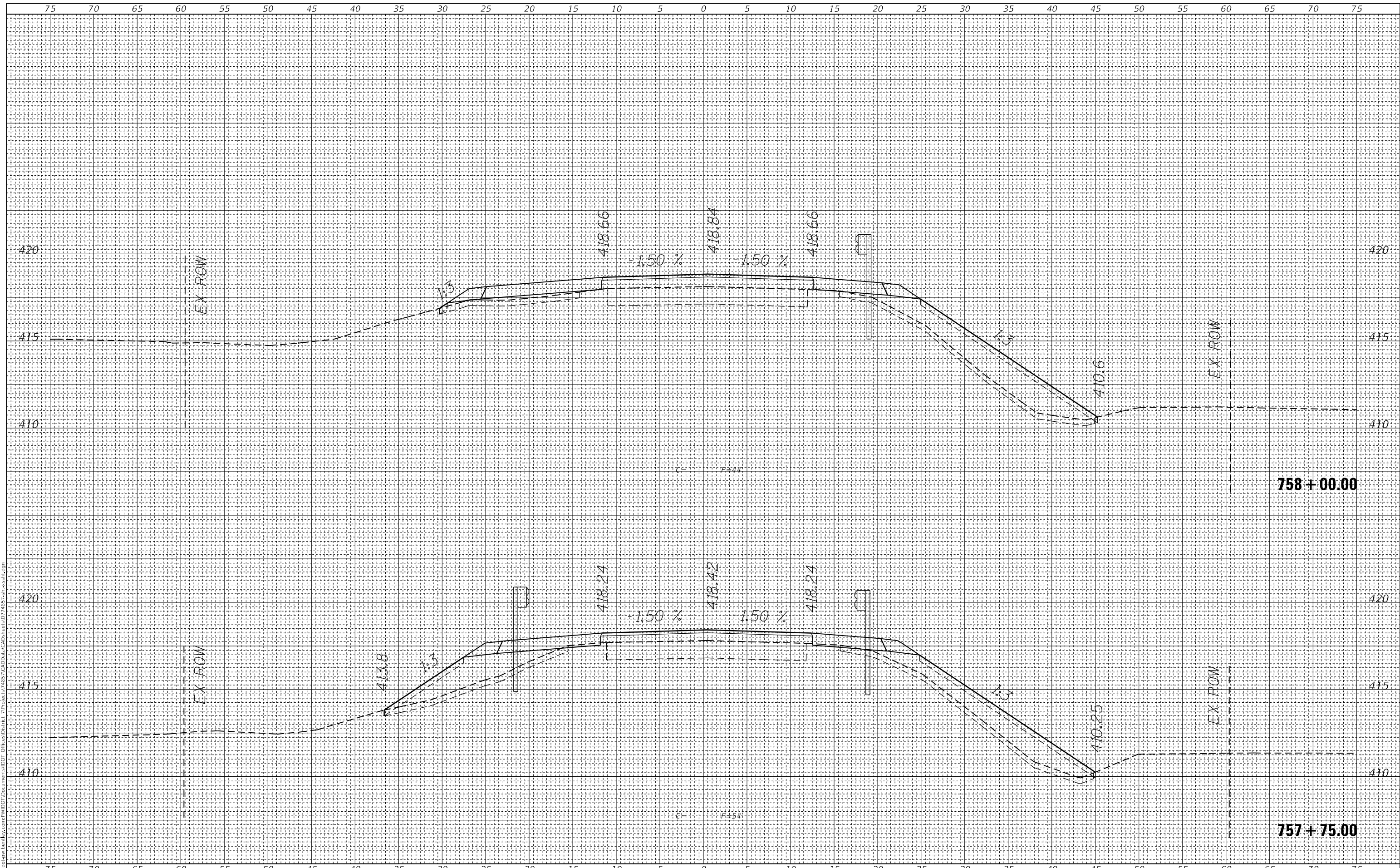

USER NAME = jessica.ville	DESIGNED - BLL	REVISED -
	DRAWN - BLL	REVISED -
PLOT SCALE = 10,0000 ' / in.	CHECKED -	REVISED -
PLOT DATE = 2/1/2024	DATE - 2/1/2024	REVISED -

**STATE OF ILLINOIS
 DEPARTMENT OF TRANSPORTATION**

CROSS SECTIONS

SCALE: 10,0000 ' / in. SHEET OF SHEETS STA. 757+75.00 TO STA. 758+00.00

F.A.P. RTE. 823	SECTION (24 BR-1) BR	COUNTY WAYNE	TOTAL SHEETS 57	SHEET NO. 50
			CONTRACT NO. 74857	
ILLINOIS FED. AID PROJECT				

FINAL SURVEY NO.	SURVEYED	DATE
NOTE BOOK	PLOTTED	
AREAS CHECKED	TEMPLATE	
	AREAS CHECKED	

ORIGINAL SURVEY NO.	SURVEYED	DATE
NOTE BOOK	PLOTTED	
AREAS CHECKED	TEMPLATE	
	AREAS CHECKED	

MODEL: Definit
FILE NAME: D:\Illinois\paw\kennedy.com\PROJECTS\74857\CAD\Drawings\CAD\Drawings\74857-58-55-58.dwg

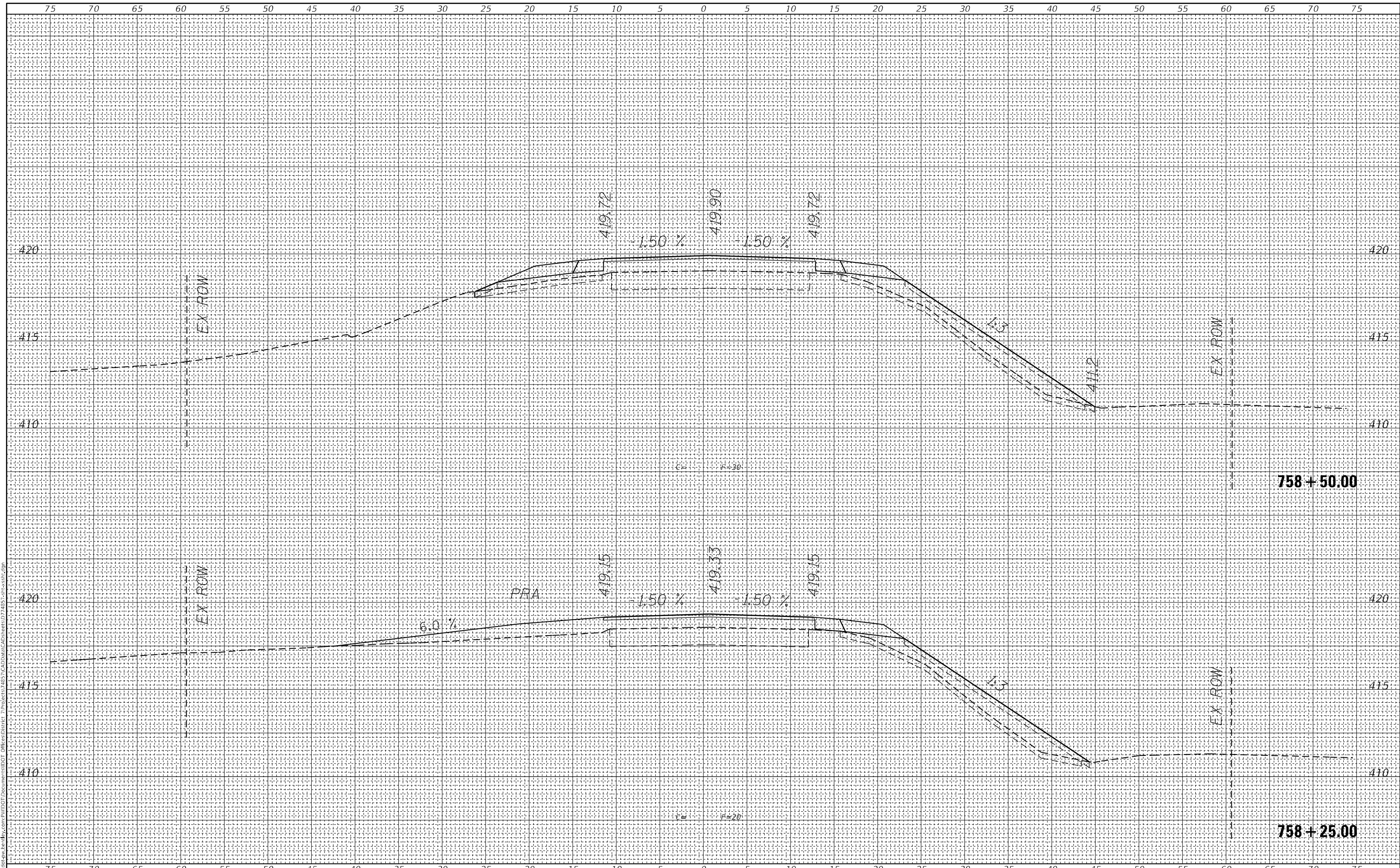

USER NAME = jessica.ville	DESIGNED -	BLL	REVISIED -
	DRAWN -	BLL	REVISIED -
PLOT SCALE = 10,0000' / in.	CHECKED -		REVISIED -
PLOT DATE = 2/1/2024	DATE -	2/1/2024	REVISIED -

**STATE OF ILLINOIS
DEPARTMENT OF TRANSPORTATION**

CROSS SECTIONS

SCALE: 10,0000' / in. SHEET OF SHEETS STA. 758+25.00 TO STA. 758+50.00

F.A.P. RTE.	SECTION	COUNTY	TOTAL SHEETS	SHEET NO.
823	(24 BR-1) BR	WAYNE	57	51
CONTRACT NO. 74857				
ILLINOIS FED. AID PROJECT				

FINAL SURVEY NO.	SURVEYED	BY	DATE
NOTE BOOK NO.	PLOTTED		
	TEMPLATE		
	AREAS CHECKED		

ORIGINAL SURVEY NO.	SURVEYED	BY	DATE
	PLOTTED		
	TEMPLATE		
	AREAS CHECKED		

MODEL: Definit
 FILE NAME: D:\work\paw\hwy\com\p\WIDOT\Documents\DOT\Drawings\DOT\Projects\74857\CAD\Drawings\CAD\Drawings\74857-58-58585.dwg

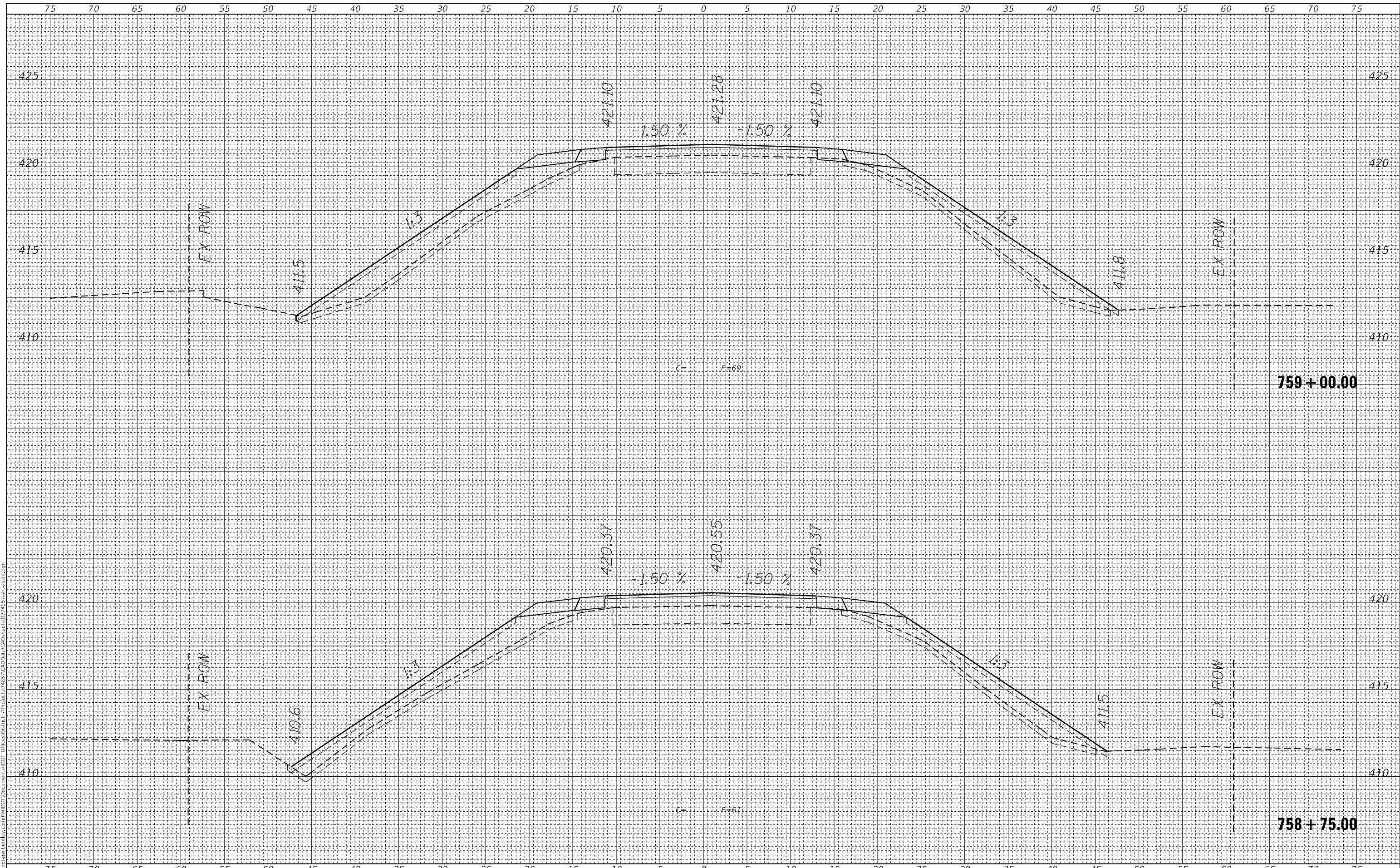

USER NAME = jessica.ville	DESIGNED - BLL	REVISIED -
	DRAWN - BLL	REVISIED -
PLOT SCALE = 10,0000 ' / in.	CHECKED -	REVISIED -
PLOT DATE = 2/1/2024	DATE - 2/1/2024	REVISIED -

**STATE OF ILLINOIS
 DEPARTMENT OF TRANSPORTATION**

CROSS SECTIONS

SCALE: 10,0000 ' / in. SHEET OF SHEETS STA. 758+75.00 TO STA. 759+00.00

F.A.P. RTE.	SECTION	COUNTY	TOTAL SHEETS	SHEET NO.
823	(24 BR-1) BR	WAYNE	57	52
CONTRACT NO. 74857				
ILLINOIS FED. AID PROJECT				

FINAL SURVEY NO.	SURVEYED	BY	DATE
NOTE BOOK NO.	PLOTTED		
	TEMPLATE		
	AREAS CHECKED		

ORIGINAL SURVEY NO.	SURVEYED	BY	DATE
	PLOTTED		
	TEMPLATE		
	AREAS CHECKED		

MODEL: Definit
 FILE NAME: D:\Illinois\paw\kennedy.com\PROJECTS\7485\CAD\DATA\CAD\DATA\7485-5810-SS12.dwg
 PROJECT: 7485\CAD\DATA\CAD\DATA\7485-5810-SS12.dwg

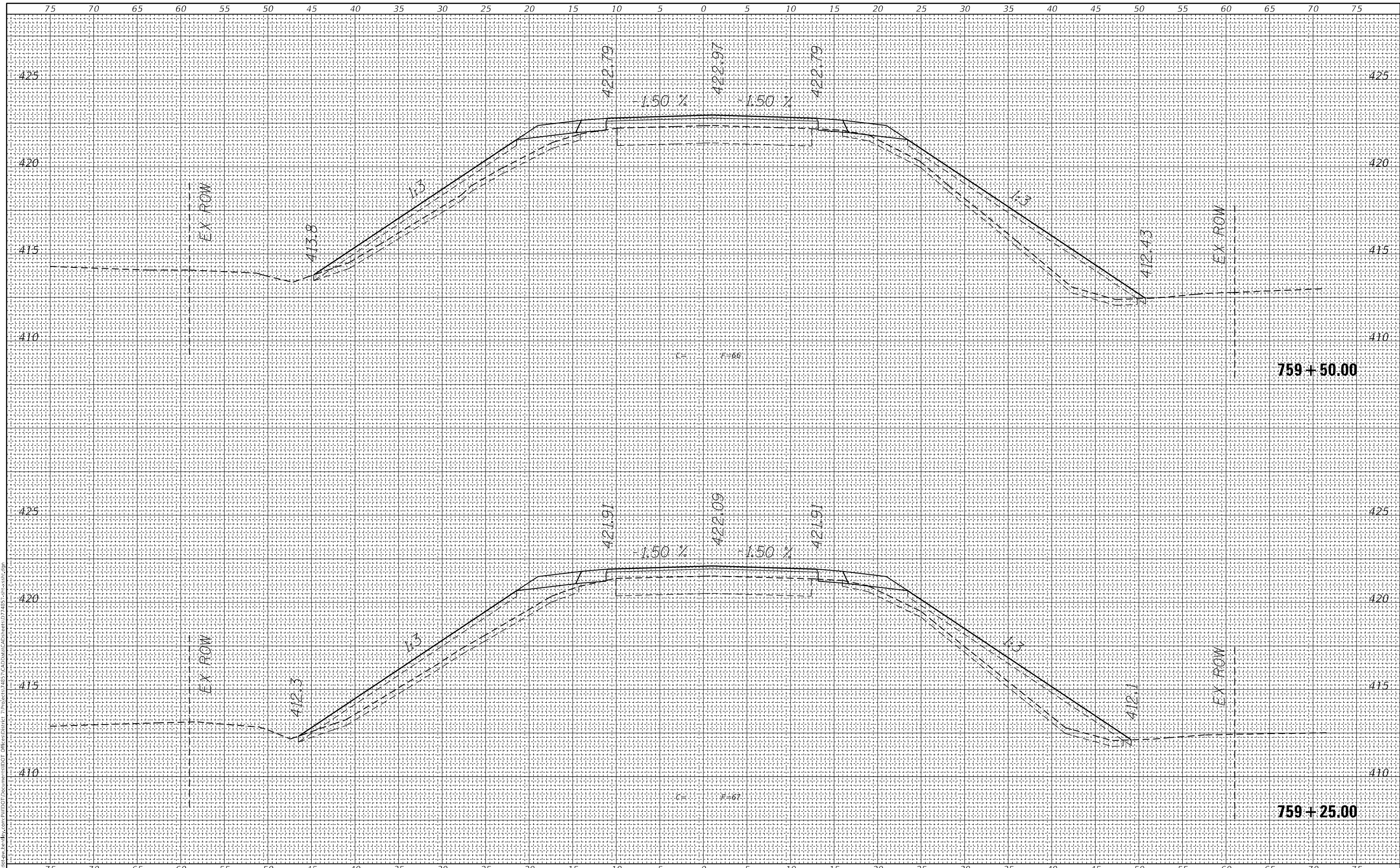

USER NAME = jessica.ville	DESIGNED - BLL	REVISED -
	DRAWN - BLL	REVISED -
PLOT SCALE = 10,0000 ' / in.	CHECKED -	REVISED -
PLOT DATE = 2/1/2024	DATE - 2/1/2024	REVISED -

**STATE OF ILLINOIS
 DEPARTMENT OF TRANSPORTATION**

CROSS SECTIONS

SCALE: 10,0000 ' / in. SHEET OF SHEETS STA. 759+25.00 TO STA. 759+50.00

F.A.P. RTE.	SECTION	COUNTY	TOTAL SHEETS	SHEET NO.
823	(24 BR-1) BR	WAYNE	57	53
CONTRACT NO. 74857				
ILLINOIS FED. AID PROJECT				

FINAL SURVEY NO.	SURVEYED	BY	DATE
NOTE BOOK	PLOTTED		
AREAS CHECKED	TEMPLATE		
	AREAS CHECKED		

ORIGINAL SURVEY NO.	SURVEYED	BY	DATE
NOTE BOOK	PLOTTED		
AREAS CHECKED	TEMPLATE		
	AREAS CHECKED		

MODEL: Default
 FILE NAME: D:\w\illinois\paw\kennedy.com\PROJECTS\74857\CAD\DATA\CAD\DATA\74857-58\cross1.dwg

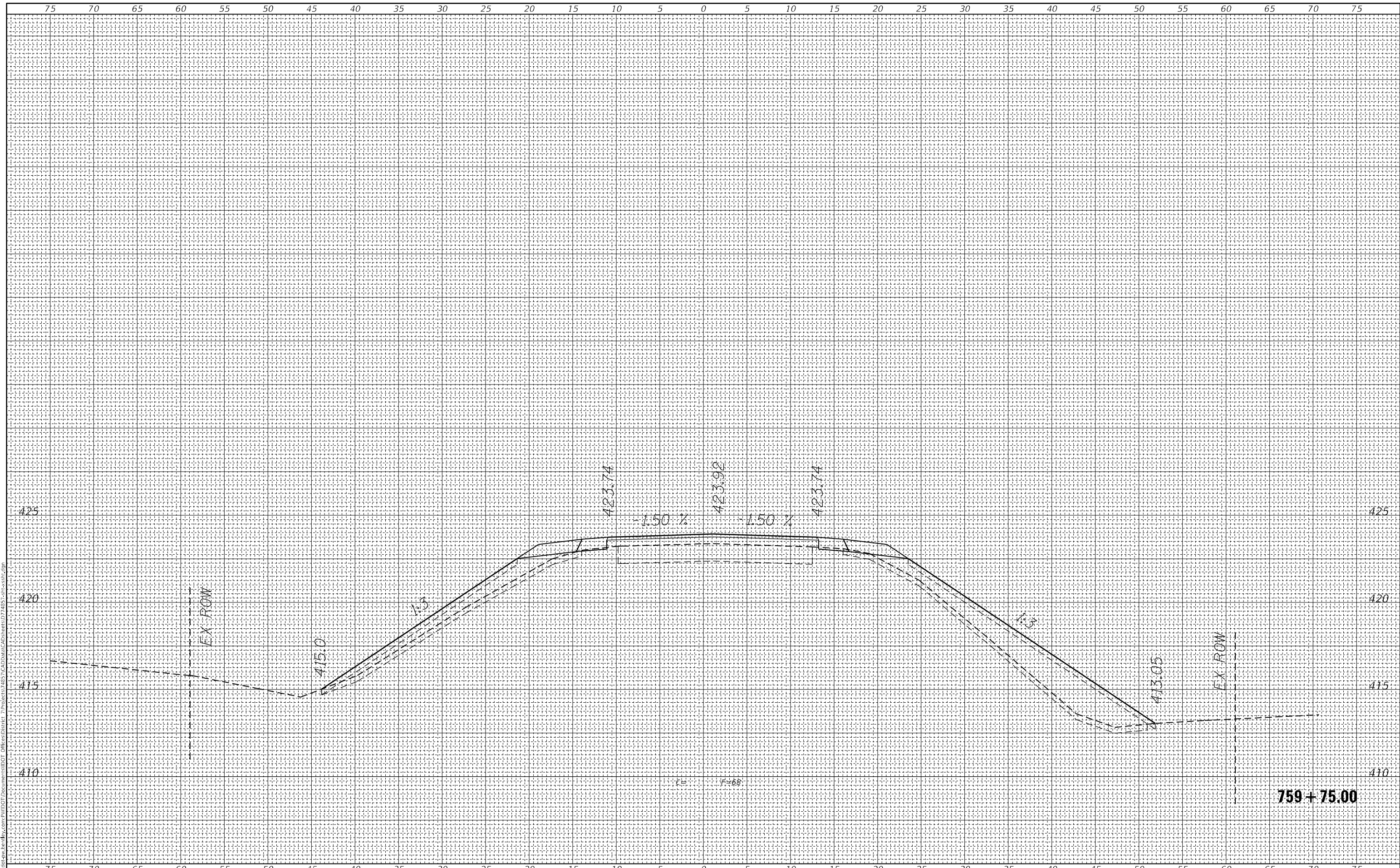

USER NAME = jessica.ville	DESIGNED - BLL	REVISIED -
	DRAWN - BLL	REVISIED -
PLOT SCALE = 10,0000' / in.	CHECKED -	REVISIED -
PLOT DATE = 2/1/2024	DATE - 2/1/2024	REVISIED -

**STATE OF ILLINOIS
 DEPARTMENT OF TRANSPORTATION**

CROSS SECTIONS

SCALE: 10,0000' / in. SHEET OF SHEETS STA. 759+75.00 TO STA. 759+75.00

F.A.P. RTE.	SECTION	COUNTY	TOTAL SHEETS	SHEET NO.
823	(24 BR-1) BR	WAYNE	57	54
CONTRACT NO. 74857				
ILLINOIS FED. AID PROJECT				

FINAL SURVEY NO.	SURVEYED	BY	DATE
NOTE BOOK	PLOTTED		
AREAS CHECKED	TEMPLATE		
	AREAS CHECKED		

ORIGINAL SURVEY NO.	SURVEYED	BY	DATE
NOTE BOOK	PLOTTED		
AREAS CHECKED	TEMPLATE		
	AREAS CHECKED		

MODEL: Definit
 FILE NAME: D:\work\paw\kennedy.com\PROJECTS\74857\CAD\DATA\CAD\BR-1\74857-24-10-24.dwg
 PROJECT: 74857-24-10-24

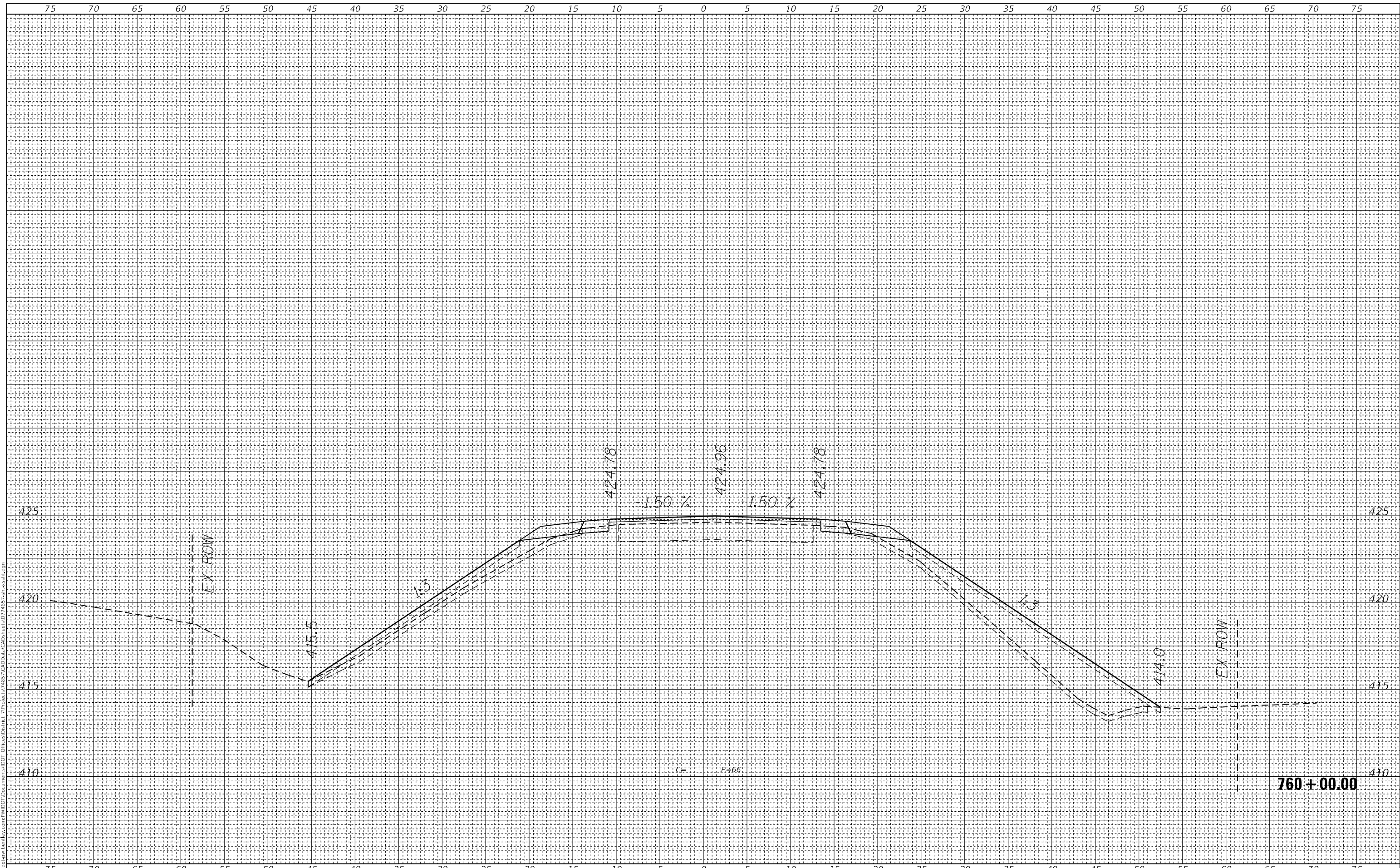

USER NAME = jessica.ville	DESIGNED - BLL	REvised -
	DRAWN - BLL	REvised -
PLOT SCALE = 10,0000' / in.	CHECKED -	REvised -
PLOT DATE = 2/1/2024	DATE - 2/1/2024	REvised -

**STATE OF ILLINOIS
 DEPARTMENT OF TRANSPORTATION**

CROSS SECTIONS

SCALE: 10,0000' / in. SHEET OF SHEETS STA. 760+00.00 TO STA. 760+00.00

F.A.P. RTE.	SECTION	COUNTY	TOTAL SHEETS	SHEET NO.
823	(24 BR-1) BR	WAYNE	57	55
CONTRACT NO. 74857				
ILLINOIS FED. AID PROJECT				

FINAL SURVEY NO.	SURVEYED	DATE
NOTE BOOK	PLOTTED	
AREAS CHECKED	TEMPLATE	
	AREAS CHECKED	

ORIGINAL SURVEY NO.	SURVEYED	DATE
NOTE BOOK	PLOTTED	
AREAS CHECKED	TEMPLATE	
	AREAS CHECKED	

MODEL: Definit
 FILE NAME: D:\w\illinois\paw\kennedy.com\PROJECTS\DOT\Documents\DOT\Drawings\Sheet\Project\74857\CAD\Drawings\CAD\Sheet\74857-56.dwg

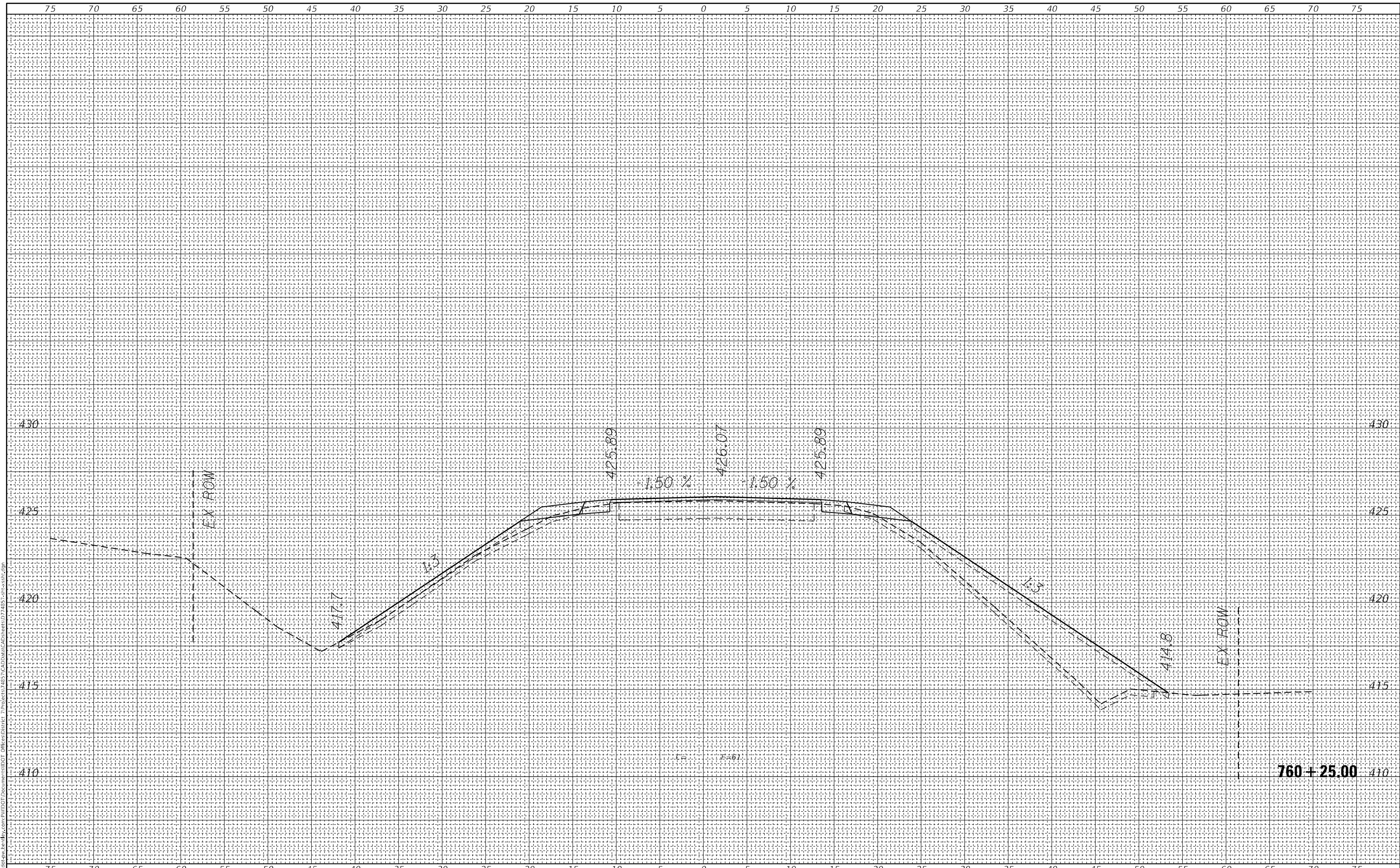

USER NAME = jessica.ville	DESIGNED - BLL	REVISED -
	DRAWN - BLL	REVISED -
PLOT SCALE = 10,0000' / in.	CHECKED -	REVISED -
PLOT DATE = 2/1/2024	DATE - 2/1/2024	REVISED -

**STATE OF ILLINOIS
 DEPARTMENT OF TRANSPORTATION**

CROSS SECTIONS

SCALE: 10,0000' / in. SHEET OF SHEETS STA. 760+25.00 TO STA. 760+25.00

F.A.P. RTE. 823	SECTION (24 BR-1) BR	COUNTY WAYNE	TOTAL SHEETS 57	SHEET NO. 56
			CONTRACT NO. 74857	
ILLINOIS FED. AID PROJECT				

FINAL SURVEY NO.	SURVEYED	BY	DATE
NOTE BOOK	PLOTTED		
AREAS CHECKED	TEMPLATE		
	AREAS CHECKED		

ORIGINAL SURVEY NO.	SURVEYED	BY	DATE
NOTE BOOK	PLOTTED		
AREAS CHECKED	TEMPLATE		
	AREAS CHECKED		

MODEL: Default
FILE NAME: D:\work\paw\kennedy.com\PROJECTS\DOT\Documents\DOT\Drawings\DOT\Drawings\DOT\7485\7485-55-55-55.dwg

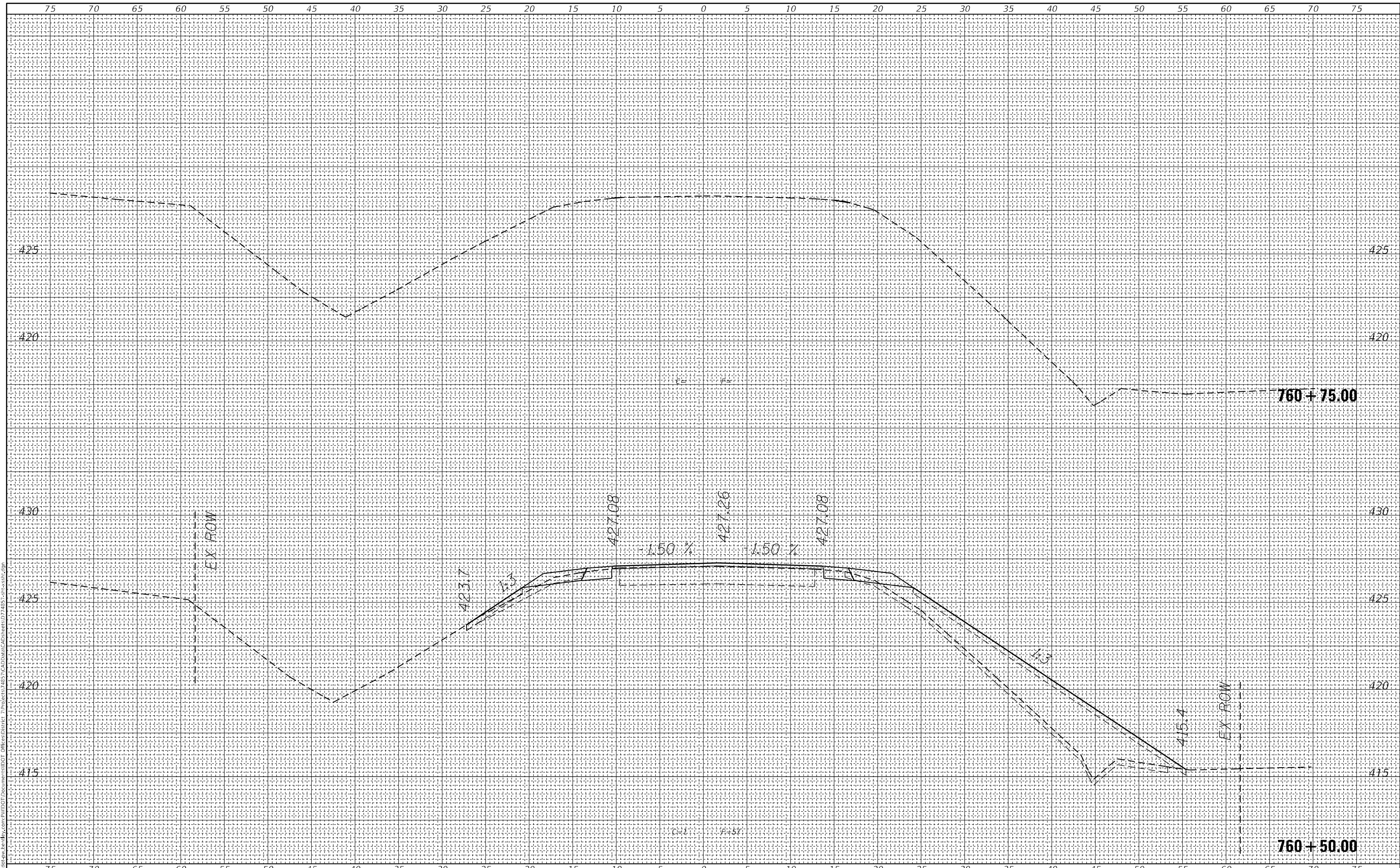

USER NAME = jessica.ville	DESIGNED - BLL	REVISIED -
	DRAWN - BLL	REVISIED -
PLOT SCALE = 10,0000' / in.	CHECKED -	REVISIED -
PLOT DATE = 2/1/2024	DATE - 2/1/2024	REVISIED -

**STATE OF ILLINOIS
DEPARTMENT OF TRANSPORTATION**

CROSS SECTIONS

SCALE: 10,0000' / in. SHEET OF SHEETS STA. 760+50.00 TO STA. 760+75.00

F.A.P. RTE.	SECTION	COUNTY	TOTAL SHEETS	SHEET NO.
823	(24 BR-1) BR	WAYNE	57	57
CONTRACT NO. 74857				
ILLINOIS FED. AID PROJECT				