

F.A. RTE.	SECTION	COUNTY	TOTAL SHEETS	SHEET NO.
*	**	WILLIAMSON	917	498

STA.	TO STA.
FED. ROAD DIST. NO.	ILLINOIS FED. AID PROJECT

* I-57, & OLD IL 13 (FAU 9629)
 ** (X1-6-2)VB-2,(X1-6)HBK-2

TYPICAL SECTION - STAGE 7A

- ① EXISTING BITUMINOUS RESURFACING (VARIES 4 1/2" TO 5 1/4")
- ② EXISTING PIPE UNDERDRAINS 4"
- ③ EXISTING BITUMINOUS SHOULDERS
- ④ EXISTING AGGREGATE SHOULDERS TYPE B (WEDGE)
- ⑤ EXISTING AGGREGATE BASE
- ⑥ EXISTING 10" P.C.C. PAVEMENT, 1 1/2" PARABOLIC CROWN
- ⑦ EXISTING 6" AGGREGATE SUB-BASE (4" ON RAMP "C")
- ⑧ PAVED SHOULDER REMOVAL
- ⑨ BITUMINOUS CONCRETE BINDER COURSE, SUPERPAVE, IL-19.0, N90 9 3/4"
- ⑩ SUB-BASE GRANULAR MATERIAL 6"
- ⑪ TEMPORARY PAINT PAVEMENT MARKING
- ⑫ PIPE UNDERDRAIN REMOVAL
- ⑬ TEMPORARY CONCRETE BARRIER
- ⑭ BITUMINOUS SHOULDERS SUPERPAVE 8"
- ⑮ BITUMINOUS CONCRETE BINDER COURSE, SUPERPAVE, IL-19.0, N90 12"
- ⑯ POLYMERIZED BITUMINOUS CONCRETE BINDER COURSE, SUPERPAVE, IL-19.0, N105 5"
- ⑰ BITUMINOUS SURFACE REMOVAL 5"
- ⑱ RUBBLIZING PORTLAND CEMENT CONCRETE PAVEMENT
- ⑲ AGGREGATE SHOULDERS TYPE A 8"
- ⑳ PAVEMENT REMOVAL
- ㉑ PROCESSING LIME MODIFIED SOILS 12"
- ㉒ BITUMINOUS CONCRETE BINDER COURSE, SUPERPAVE, IL-19.0, N90 11"
- ㉓ BITUMINOUS CONCRETE BINDER COURSE, SUPERPAVE, IL-19.0, N90 7 3/4"
- ㉔ CONCRETE GUTTER, TYPE B
- ㉕ SUB-BASE GRANULAR MATERIAL, TYPE C
- ㉖ POLYMERIZED BITUMINOUS CONCRETE BINDER COURSE, SUPERPAVE, IL-19.0, N105 (VAR)
- ㉗ POLYMERIZED BITUMINOUS CONCRETE SURFACE COURSE, SUPERPAVE, MIX E, N105 1 1/2"
- ㉘ CONCRETE BARRIER, DOUBLE FACE, 42 INCH HEIGHT
- ㉙ TEMPORARY SHEET PILING
- ㉚ BITUMINOUS SHOULDER SUPERPAVE 6 1/2"
- ㉛ STONE RIPRAP, CLASS A3
- ㉜ STEEL PLATE BEAM GUARDRAIL, TYPE A
- ㉝ AGGREGATE SHOULDERS, TYPE B (WEDGE)
- ㉞ BITUMINOUS CONCRETE BINDER COURSE, SUPERPAVE, IL-19.0, N90 12 3/4"
- ㉟ TEMPORARY STEEL PLATE BEAM GUARDRAIL, TYPE A
- ㊱ PIPE UNDERDRAIN 4"
- ㊲ POLYMERIZED BITUMINOUS CONCRETE BINDER COURSE, SUPERPAVE, IL-19.0, N105 2 1/4"
- ㊳ STABILIZED SUB-BASE (VARIABLE DEPTH)
- ㊴ STRIP REFLECTIVE CRACK CONTROL
- ㊵ BITUMINOUS CONCRETE BINDER COURSE, SUPERPAVE, IL-19.0, N90 5"
- ㊶ BITUMINOUS CONCRETE BINDER COURSE, SUPERPAVE, IL-19.0, N90 15"
- ㊷ BITUMINOUS CONCRETE BINDER COURSE, SUPERPAVE, IL-19.0, N90 (VAR)
- ㊸ SUB-BASE GRANULAR MATERIAL 10"
- ㊹ POLYMERIZED BITUMINOUS CONCRETE SURFACE COURSE, SUPERPAVE, MIX E, N105 (VAR.)
- ㊺ BITUMINOUS CONCRETE SURFACE COURSE, SUPERPAVE, MIX C, N70 1 1/2"

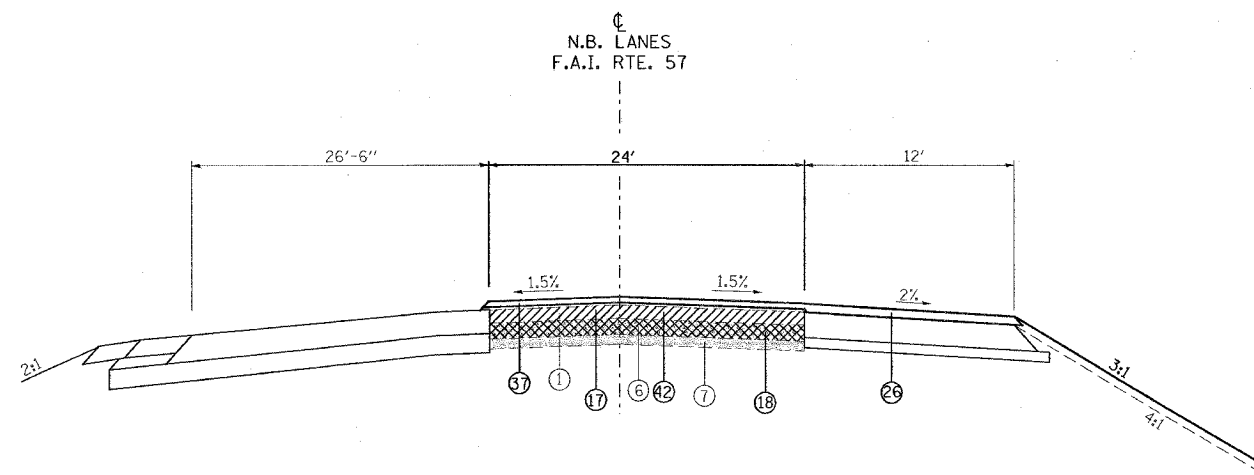

TO BE USED:
 STA. 1506+90 TO STA. 1509+70

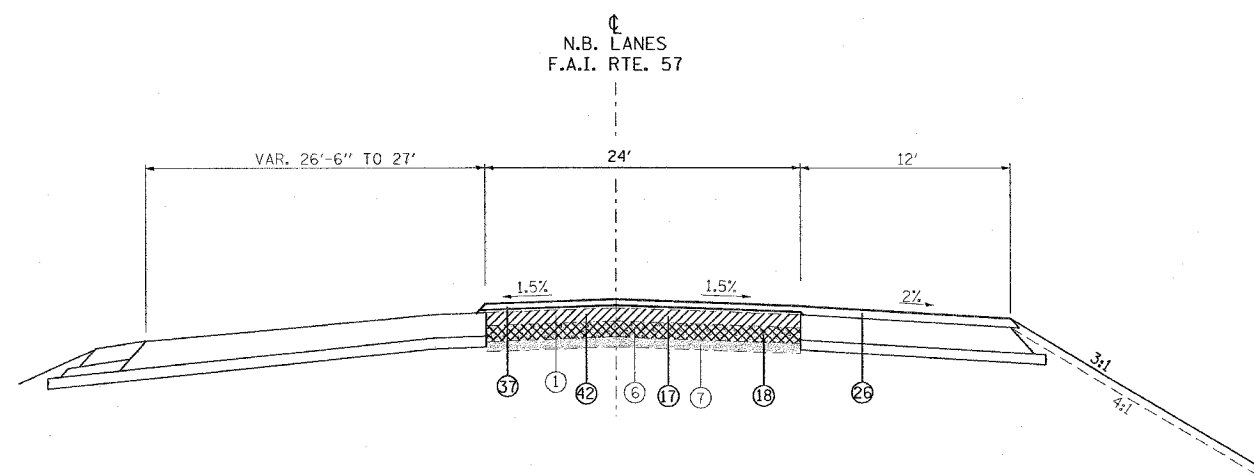

TO BE USED:
 STA. 1509+70 TO STA. 1513+00

STAGE 7A NOTES

USE NIGHT-TIME WORK HOURS FOR ALL WORK ON STAGE 7A
 APPLY TRAFFIC STANDARDS 701400, 701401, AND 701411

NORTHBOUND I-57

1. KEEP TEMPORARY CONCRETE BARRIER FROM STAGE 7 IN PLACE.
2. REDUCE TRAFFIC TO ONE LANE NEAR STA. 1513+00
3. RUBBLIZE AND RESURFACE EXISTING PAVEMENT ONE LANE AT A TIME.

SOUTHBOUND I-57

1. KEEP TEMPORARY CONCRETE BARRIER FROM STAGE 7 IN PLACE.
2. REDUCE TRAFFIC TO ONE LANE NEAR STA. 1507+17.
3. RUBBLIZE AND RESURFACE EXISTING PAVEMENT ONE LANE AT A TIME.

REVISIONS	
NAME	DATE

ILLINOIS DEPARTMENT OF TRANSPORTATION

**FAI-57
 STAGE 7A
 TYPICAL AND NOTES
 SHEET 1 OF 9**

SCALE: VERT. NONE
 HORIZ. DATE

DRAWN BY CNH
 CHECKED BY