

EXISTING BRIDGE CROSS SECTION
(Looking North)

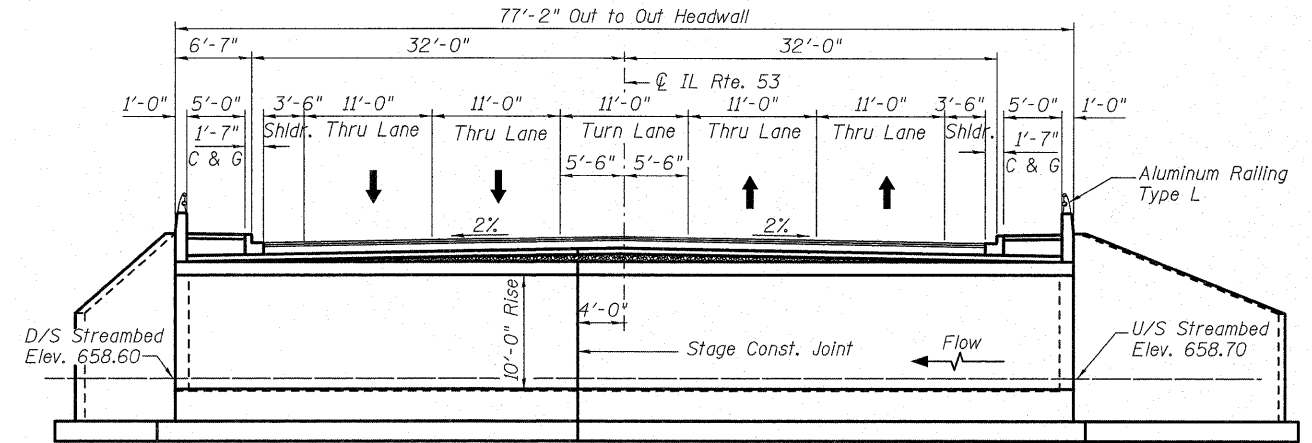

FINAL STAGE
(Looking North)

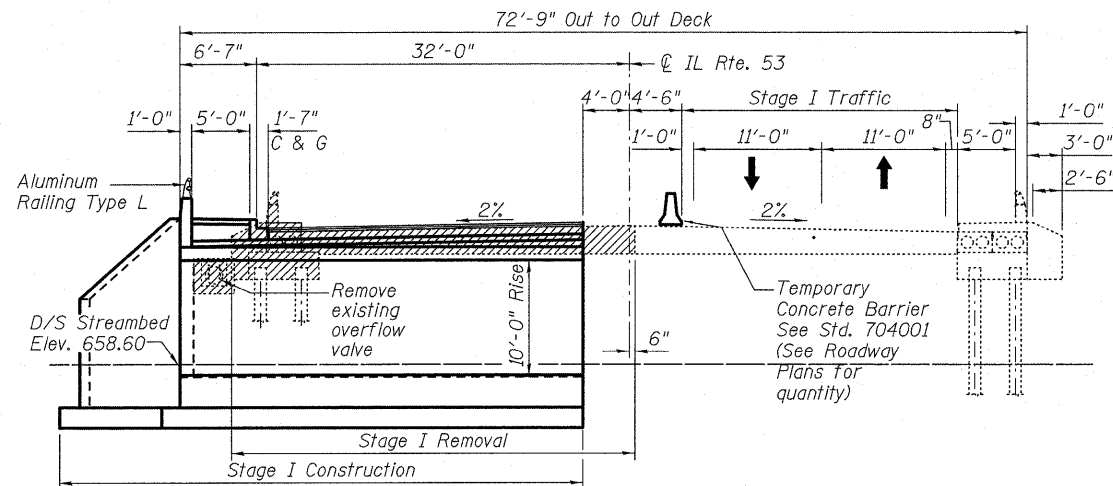

STAGE I REMOVAL & CONSTRUCTION
(Looking North)

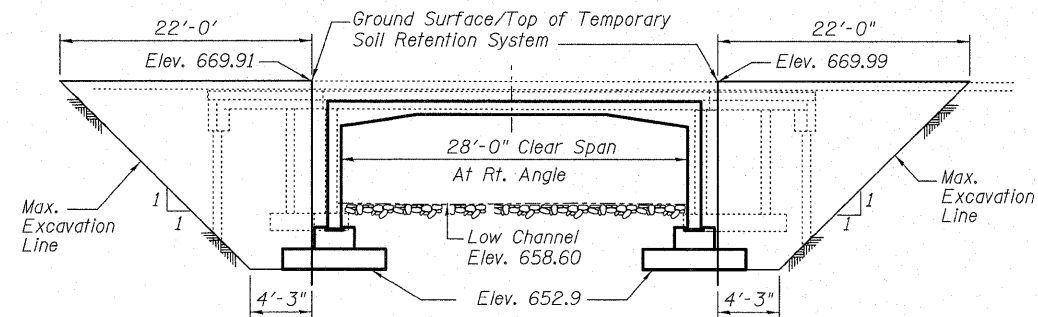

SOUTH END

NORTH END

TEMPORARY SOIL RETENTION SYSTEM

LEGEND

 Indicates removal of existing Structure except piles.

A cantilevered sheet piling design does not appear feasible and additional member or other retention systems may be necessary. The Contractor shall submit a temporary soil retention system design including plan details and calculations for review and acceptance by the Engineer.

GENERAL NOTES

- Reinforcement bars shall conform to the requirements of ASTM A 706 Gr 60. See Special Provisions.
- Reinforcement bars designated (E) shall be epoxy coated.
- The option of using a precast footing is not allowed.
- The option of using precast wingwall is not allowed.
- Layout of slope protection system may be varied in the field to suit ground conditions as directed by the Engineer.
- After the keyways have been grouted and cured, the joints on all three sides of the structure shall be externally sealed using 13" wide external sealing bands conforming to Article 1057.01. Cost included with Three-sided Precast Concrete Structure 28'x10'.
- All details shown are developed assuming the use of cast-in-place headwalls and wingwalls placed as shown. The Contractor has the option of using precast headwalls. If the precast option is used, the details for the headwall shall be submitted to the Engineer for approval.
- The footing design is based on the following maximum reactions applied at the top of the footing pedestal:
Vertical: 10.0 K/ft DL + 4.1 K/ft LL
Horizontal: 4.0 K/ft DL + 1.8 K/ft LL
- The contractor shall verify that the selected structure meet these design parameters. If the design parameters are exceeded, a complete footing design with calculations, details and the required structural seals shall be submitted for review and approval.
- Excavation behind existing abutment walls shall be performed to balance front and back soil pressure before removing the existing superstructure. The Contractor shall sawcut the upper portion of the existing abutment at the Stage Removal Line before Stage I Removal to ensure the remaining portion will not be prematurely damaged.
- Cost of excavation, furnishing and placing of Porous Granular Embankment behind the structure are included in the pay item Three Sided Precast Concrete Structures, 28'x10'.
- Structural Seal does not include the design of precast elements.
- Dimensions for the Three-sided Precast are for a Hy-Span section and will vary per manufacturer.

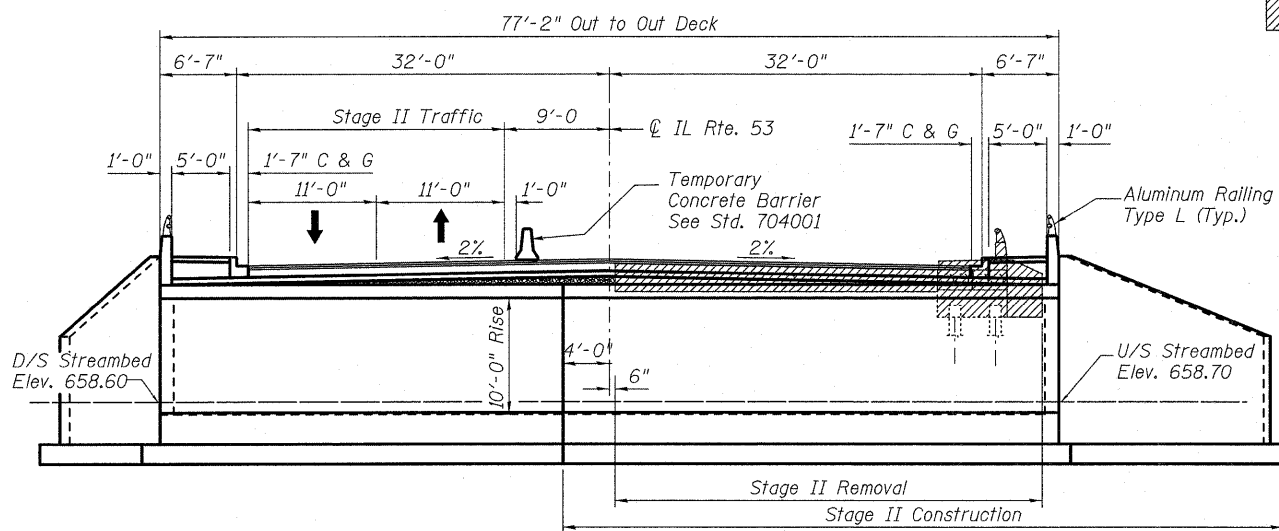

STAGE II REMOVAL & CONSTRUCTION
(Looking North)



USER NAME =	DESIGNED - JPM	REVISED -
	CHECKED - JXH	REVISED -
PLOT SCALE =	DRAWN - MPS	REVISED -
PLOT DATE =	CHECKED - JPM/JXH/TPG	REVISED -

**STATE OF ILLINOIS
DEPARTMENT OF TRANSPORTATION**

**STAGE CONSTRUCTION DETAILS
STRUCTURE NO. 022-3054 STA. 100 + 00.15**

SHEET NO. S3 OF S12 SHEETS

F.A.P. RTE.	SECTION	COUNTY	TOTAL SHEETS	SHEET NO.
BTO	534R-B	DUPAGE	51	31
DATE: NOVEMBER 16, 2011 ILLINOIS FED. AID PROJECT			CONTRACT NO. 60M83	