

DETAIL - "D"

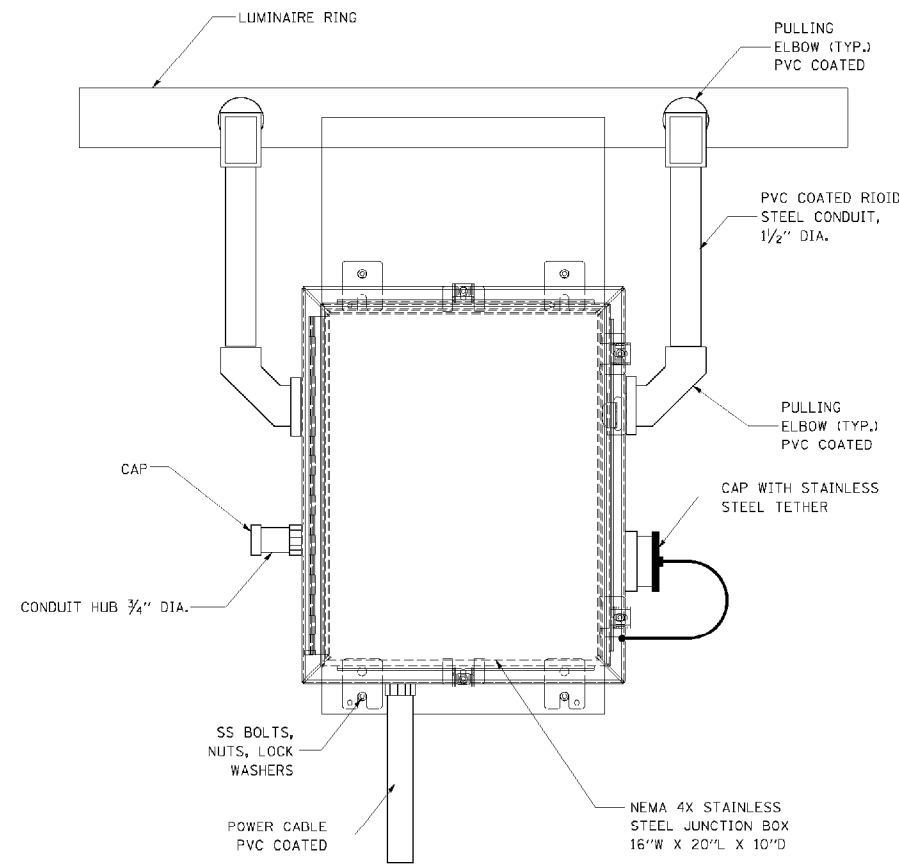

FRONT VIEW
N.T.S.

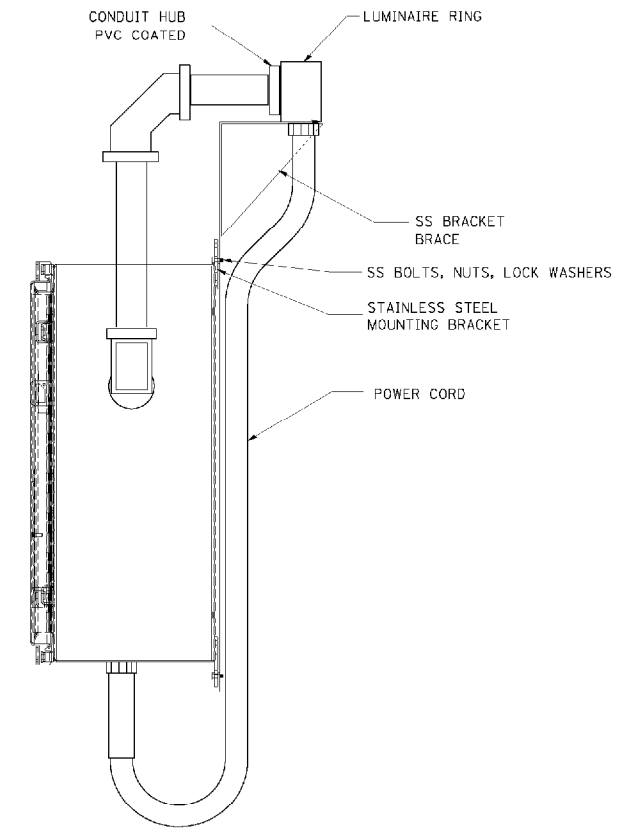

SIDE VIEW
N.T.S.

LUMINAIRE RING TERMINAL BOX

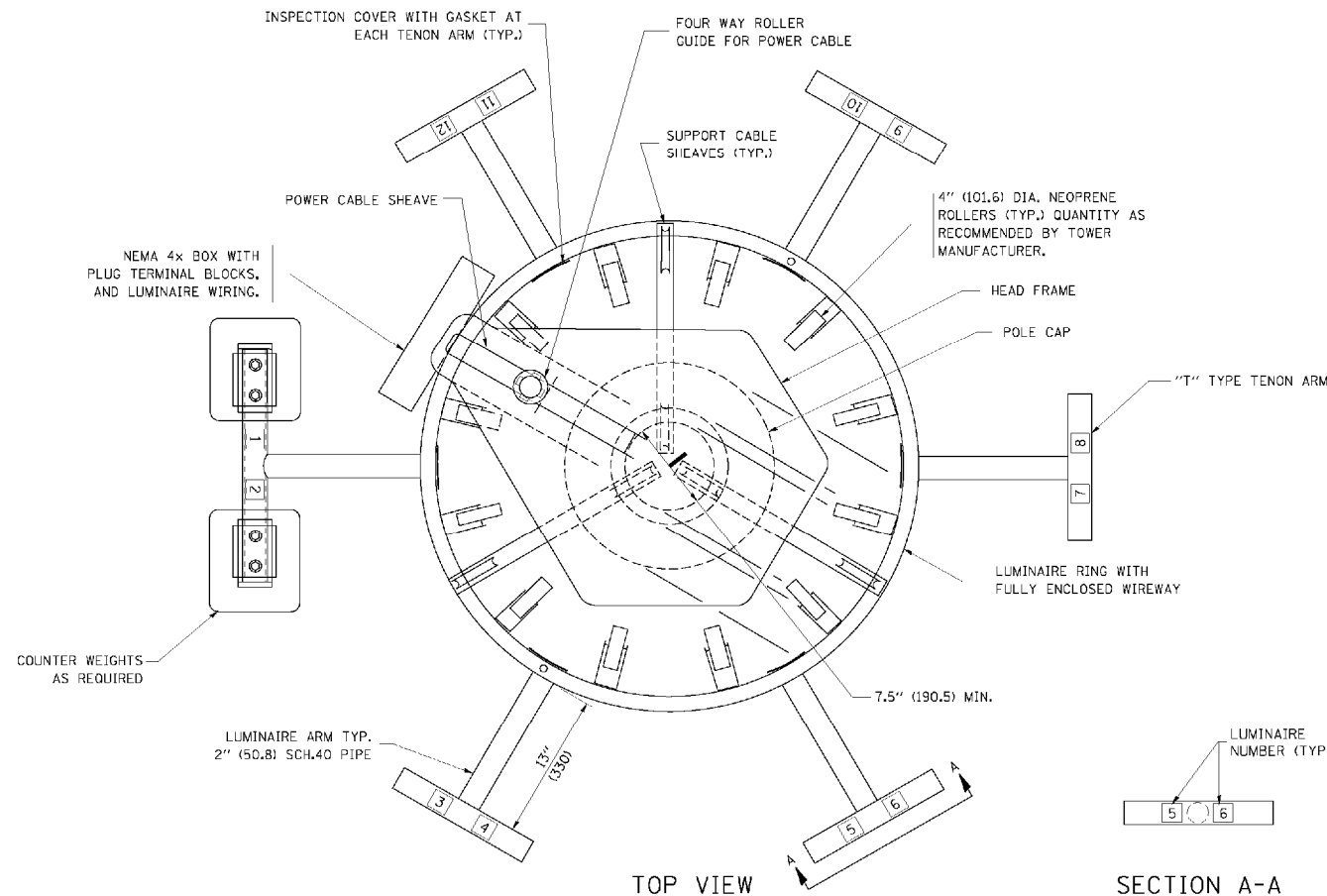

TOP VIEW

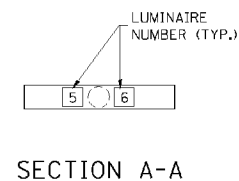

SECTION A-A

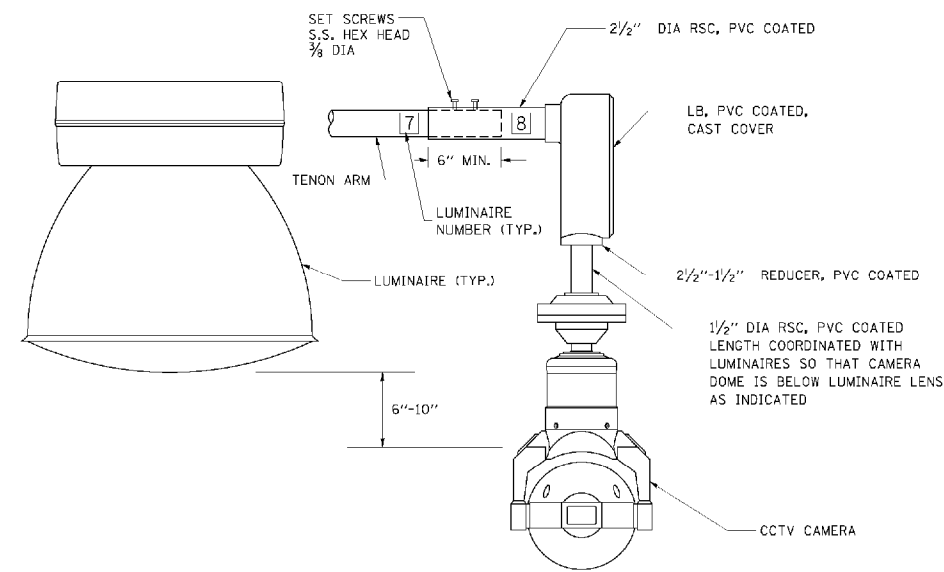

CCTV CAMERA MOUNTING DETAIL

NOTES:

- LUMINAIRE WIRES SHALL EXTEND 24 INCHES (609 mm) LONGER THAN THEIR RESPECTIVE TENON ARM AND SHALL BE TRAINED BACK INTO THE ARM WHICH SHALL THEN BE CLOSED WITH A CAP AS SPECIFIED. ALL WIRES SHALL BE CAPPED WITH HEAT SHRINK INSULATING BOOTS, CRIMP CAPS ARE UNACCEPTABLE. ALL RING WIRES SHALL BE TAGGED WITH WIRE MARKERS AT BOTH ENDS. THE TENON ARMS SHALL ALSO BE TAGGED CORRESPONDING TO THE WIRING CONTAINED WITHIN.
- SPLICING WILL NOT BE ALLOWED WITHIN THE LUMINAIRE RING.
- ALL TOWER SHAFT HARDWARE, SUCH AS GROUND LUGS, JUNCTION BOXES, HARDWARE FOR THE HANDHOLE DOOR, INCLUDING THE HANDLE/LATCH MECHANISM, HINGE AND DOOR STOP, SHALL BE STAINLESS STEEL. ALL CONDUIT AND CONDUIT FITTINGS SHALL BE PVC COATED GALVANIZED STEEL.
- ALL MULTI-CONDUCTOR CABLES SHALL BE FITTED WITH A HEAT-SHRINK MULTI-LEG BOOT. THE BOOT SHALL MEET MILITARY SPECIFICATION MIL-T-81765/1.

FILE NAME = c:\pwwork\pwwork\drivakosqn\d0108315\be005.dgn	USER NAME = drivakosqn	DESIGNED - DRAWN -	REVISED - 09-02-03 REVISED - 03-22-10	STATE OF ILLINOIS DEPARTMENT OF TRANSPORTATION	HIGH MAST LIGHT TOWER 120 FT TO 140 FT (36 m TO 43 m)			F.A. RTE. 80	SECTION 2011-046-L	COUNTY WILL	TOTAL SHEETS 106	SHEET NO. 54
PLOT SCALE - 50.0000 "/> <td>CHECKED -</td> <td>REVISED - 09-02-10</td> <td>SCALE: NONE</td> <td>SHEET NO. 2 OF 3 SHEETS</td> <td>STA.</td> <td>TO STA.</td> <td colspan="2" style="text-align: center;">BE-505</td> <td colspan="2">CONTRACT NO. 60P56</td>		CHECKED -	REVISED - 09-02-10		SCALE: NONE	SHEET NO. 2 OF 3 SHEETS	STA.	TO STA.	BE-505		CONTRACT NO. 60P56	
PLOT DATE - 9/21/2010		DATE -	REVISED -		FED. ROAD DIST. NO. 1 ILLINOIS FED. AID PROJECT							