

**ELEVATION
TYPICAL INTERIOR UNIT**
Even number of panels/interior unit required.

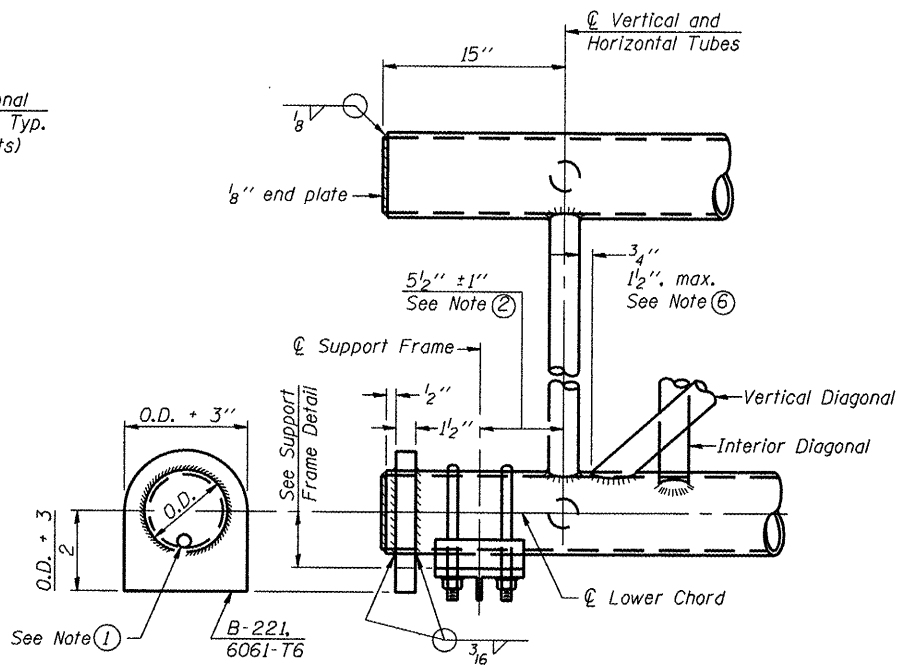

SUPPORT END DETAIL FOR EXTERIOR UNIT

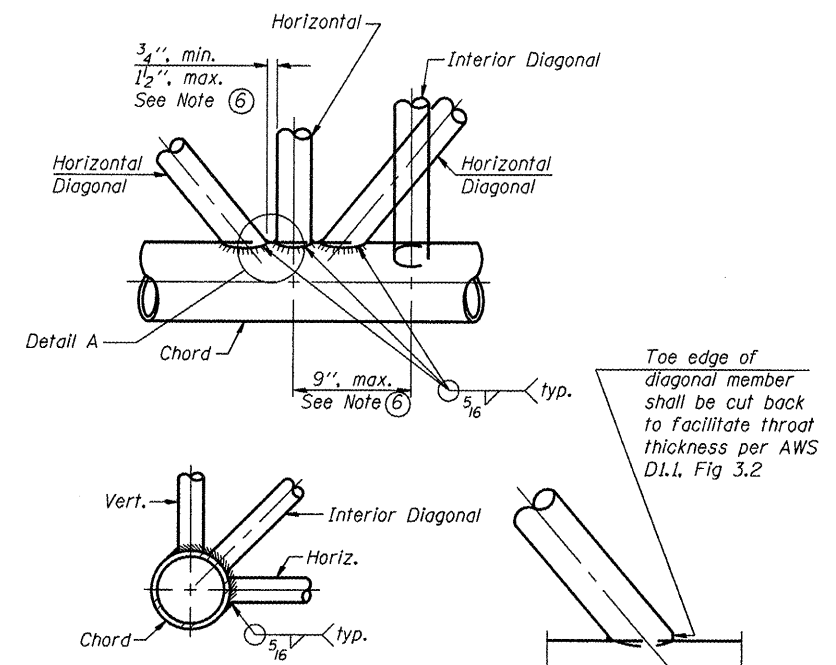

TYPICAL JOINT DETAILS

DETAIL A

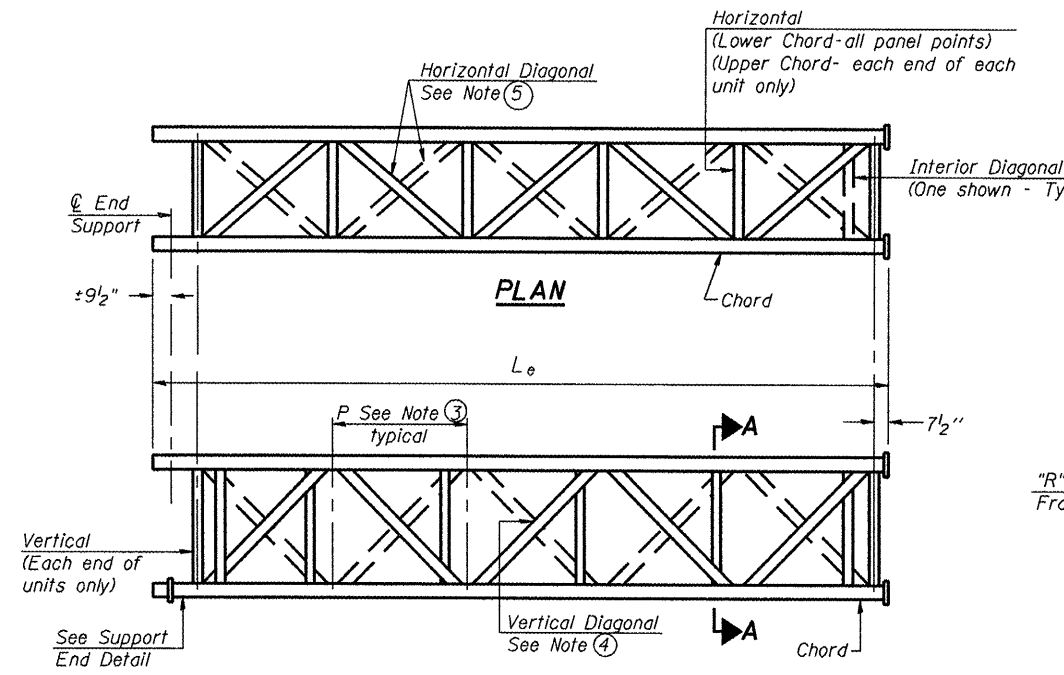

**ELEVATION
TYPICAL EXTERIOR UNIT**
Even or odd number of panels/exterior units allowed.

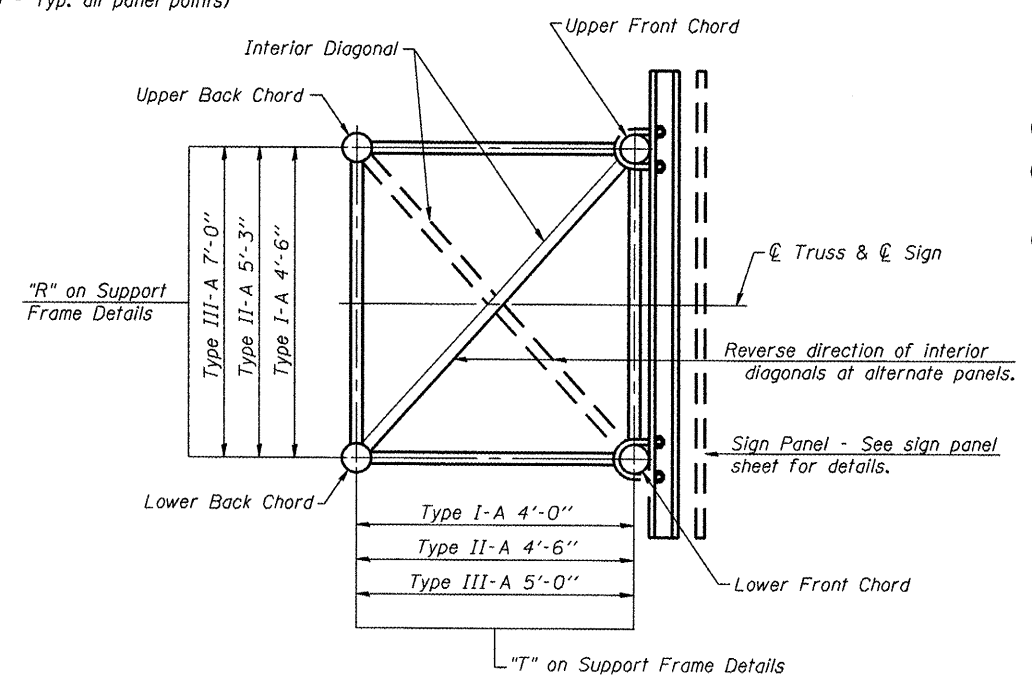

SECTION A-A

- ① Contractor may alternatively use standard aluminum drive-fit cap to close end. 1/2" ϕ drain hole in end plate/drive-fit cap. (Typ. at ends of all chords)
- ② 5 1/2" end dimension may vary by $\pm 1"$ to provide uniform panel spacing (P).
- ③ Panel spacing (P) shall be uniform for entire truss and between 4'-0" and 5'-0" for Type I-A or 4'-0" and 5'-6" for Types II-A and III-A.
- ④ Vertical Diagonals in front and back face shall alternate.
- ⑤ Hidden lines show wind bracing alternates direction between planes of top and bottom chords.
- ⑥ All diagonals shall be detailed for minimum offset from the panel point based on the following: Offset shall be such as to provide a 3/4" minimum to 1 1/2" maximum clearance between any diagonal and any horizontal or vertical member, and to provide clearance for U-bolt connections of signs or walkway brackets.

05-A-2

1-20-11

FILE NAME =	USER NAME = pateluj	DESIGNED -	REVISED -
cr:\pw\work\p\ridot\pateluj\d0258292\0366828-ahd-details.DGN		DRAWN -	REVISED -
		CHECKED -	REVISED -
		DATE -	REVISED -

**STATE OF ILLINOIS
DEPARTMENT OF TRANSPORTATION**

**OVERHEAD SIGN STRUCTURES - ALUMINUM TRUSS
DETAILS FOR TRUSS TYPES I-A, II-A AND III-A**

SCALE: _____ SHEET NO. 1 OF 1 SHEETS STA. _____ TO STA. _____

F.A.I. RTE.	SECTION	COUNTY	TOTAL SHEETS	SHEET NO.
VAR	D3 OVD MESSAGE SG - 2012	VAR	49	15
ILLINOIS			CONTRACT NO. 66B28	