

**TRUSS UNIT TABLE**

Structure Number	Station	Design Truss Type	Exterior Units (2)			Interior Unit				Upper & Lower Chord		Verticals; Horizontals; Vertical, Horizontal, and Interior Diagonals		Camber at Midspan	Splicing Flange					
			No. Panels per Unit	Unit Lgth.(L <sub>u</sub> )	Panel Lgth.(P)	No. Req'd.	No. Panels per Unit	Unit Lgth.(L <sub>i</sub> )	Panel Lgth.(P)	O.D.	Wall	O.D.	Wall		Bolts		Weld Sizes		A	B
															No./Splice	Dia.	W	W <sub>1</sub>		
3S0501080L096.0	785+00	III-A	7	32'-9 1/2"	4'-5"	0	--	--	--	7"	5/16"	3 1/4"	5/16"	0.77"	6	1"	7/16"	5/16"	11 1/2"	15"
3S0061080R072.5	437+50	III-A	7	32'-9 1/2"	4'-5"	0	--	--	--	7"	5/16"	3 1/4"	5/16"	0.77"	6	1"	7/16"	5/16"	11 1/2"	15"
3S0501039R049.0	190+00	III-A	7	32'-9 1/2"	4'-5"	0	--	--	--	7"	5/16"	3 1/4"	5/16"	0.77"	6	1"	7/16"	5/16"	11 1/2"	15"
3S0501039L068.5	540+00	III-A	7	32'-9 1/2"	4'-5"	0	--	--	--	7"	5/16"	3 1/4"	5/16"	0.77"	6	1"	7/16"	5/16"	11 1/2"	15"
3S0461057R305.0	555+00	III-A	7	32'-9 1/2"	4'-5"	0	--	--	--	7"	5/16"	3 1/4"	5/16"	0.77"	6	1"	7/16"	5/16"	11 1/2"	15"
3S0461057L319.9	547+30	III-A	7	32'-9 1/2"	4'-5"	0	--	--	--	7"	5/16"	3 1/4"	5/16"	0.77"	6	1"	7/16"	5/16"	11 1/2"	15"

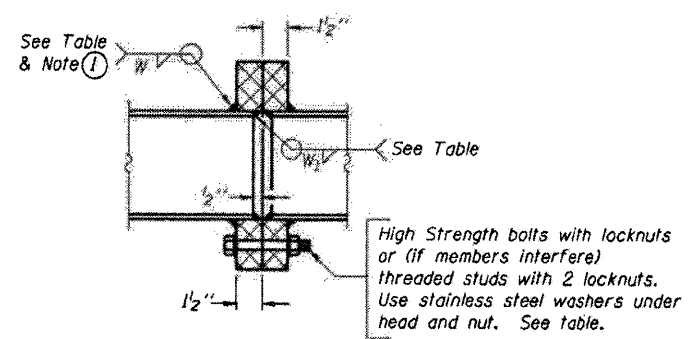

**SECTION B-B**

① Splicing Flanges shall be attached to each truss unit with the truss shop assembled to camber shown. Truss units shall be in proper alignment and flange surfaces shall be shop bolted into full contact before welding. Sufficient external welds or tacks shall be made to secure flanges until remaining welds are made after disassembly. Adjacent flanges shall be "match marked" to insure proper field assembly.

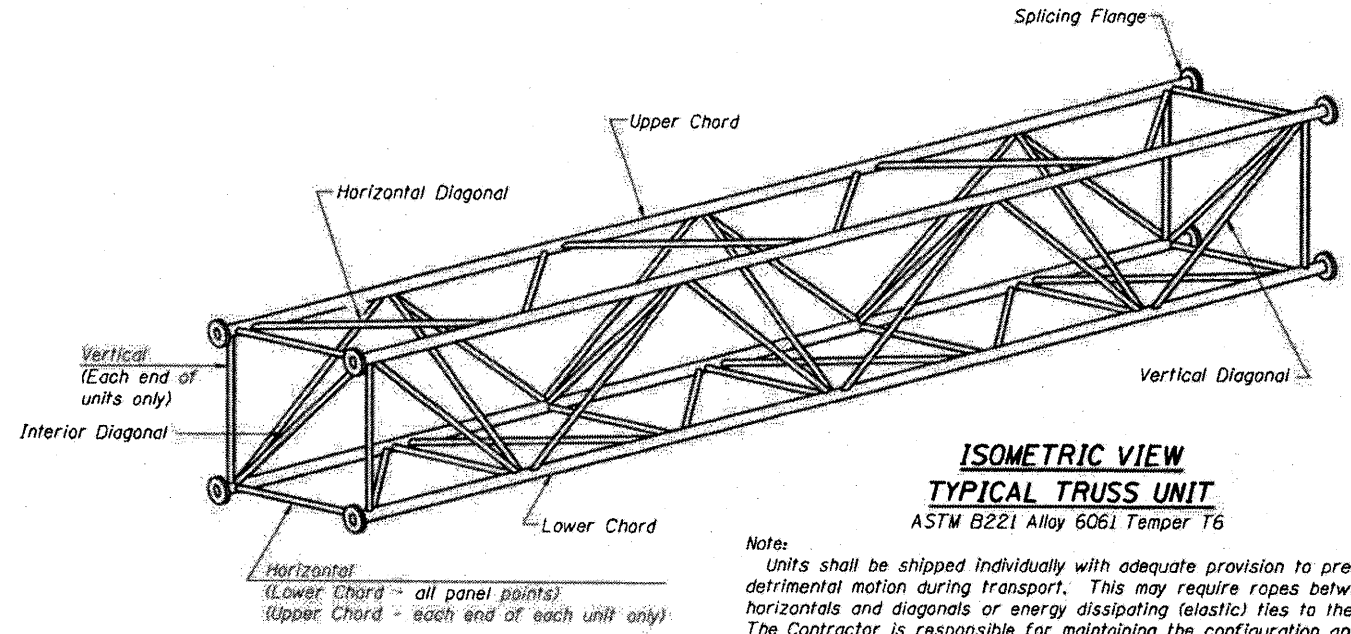

**ISOMETRIC VIEW TYPICAL TRUSS UNIT**  
ASTM B221 Alloy 6061 Temper T6

Note: Units shall be shipped individually with adequate provision to prevent detrimental motion during transport. This may require ropes between horizontals and diagonals or energy dissipating (elastic) ties to the vehicle. The Contractor is responsible for maintaining the configuration and protection of the units.

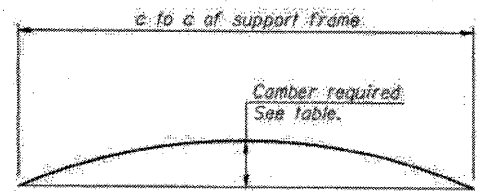

**CAMBER DIAGRAM**

Camber curve shown is theoretical. Actual camber attained by slope changes at splices between units.

**CAMBER ATTAINMENT EXAMPLES:**

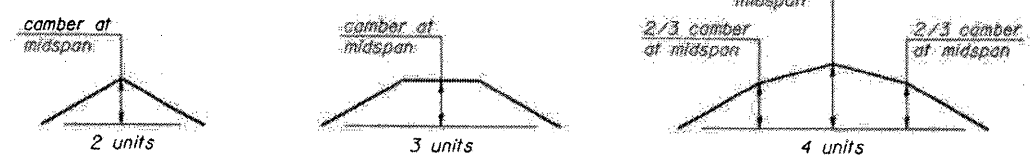

Camber shown is for fabrication only, measured with truss fully supported. (No-load condition)

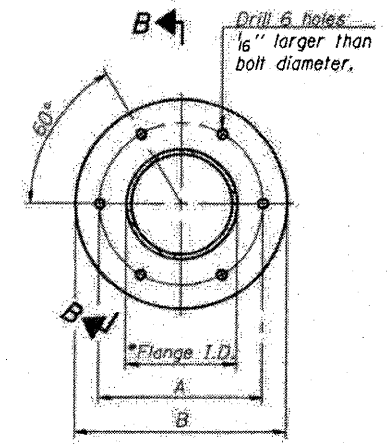

**TRUSS TYPES I-A, II-A, & III-A**

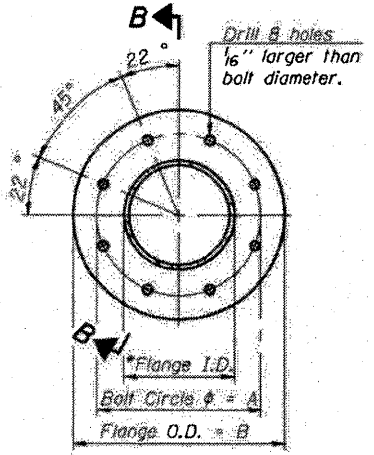

**TRUSS TYPES II-A & III-A**

**SPLICING FLANGES**

ASTM B221, Alloy 6061-T6 or ASTM B209, Alloy 6061-T651

\*To fit O.D. of Chord with maximum gap of 1/16"

0S4-A-2

1-20-11

FILE NAME: 03\pwr_sdr_k\spaldr\spaldr\02290292\030608	USER NAME: j.patel@jg	DESIGNED: YOGESH PATEL	REVISED: -	<b>STATE OF ILLINOIS DEPARTMENT OF TRANSPORTATION</b>	<b>OVERHEAD SIGN STRUCTURES - ALUMINUM TRUSS DETAILS FOR TRUSS TYPES I-A, II-A AND III-A</b>	F.A.I. RTE.:	SECTION:	COUNTY:	TOTAL SHEETS:	SHEET NO.:
PLT SCALE: 99.9999 / in.	DRAWN: YOGESH PATEL	CHECKED: RON WOODSHANK	REVISED: -			VAR:	D3 OVD MESSAGE 56 - 2012	VAR:	50	10
PLT DATE: 3/8/2012	DATE: -	REVISED: -	REVISED: -			SCALE:	SHEET NO. 1 OF 1 SHEETS	STA.:	TO STA.:	CONTRACT NO. 66028
						ILLINOIS				