

PILE DATA

Type: Steel HP12x63
 Nominal Required Bearing: 453 k
 Factored Resistance Available: ... 250 k
 Est. Length: 17'
 No. Production Piles: 5
 No. Test Piles: 1

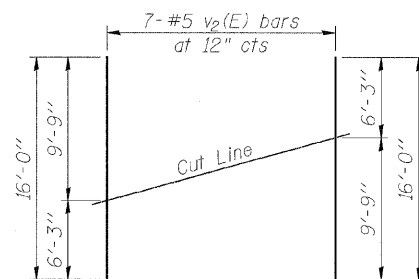

Order $v_2(E)$ full length. Cut as shown and use remainder of bars in opposite face.

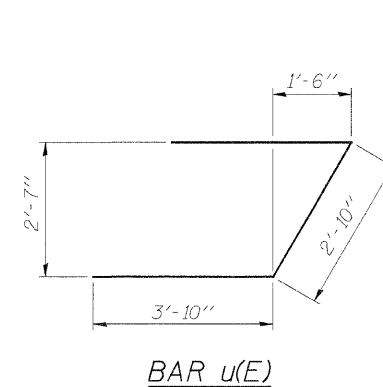
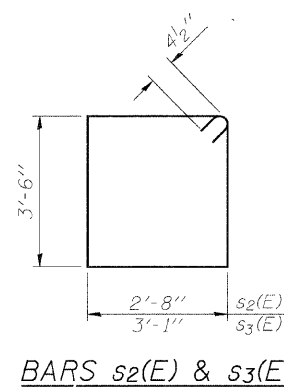
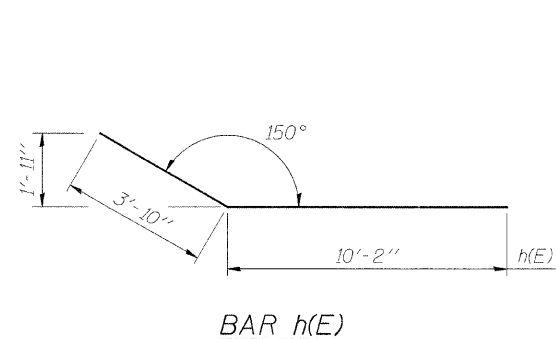

BILL OF MATERIAL

Bar	No.	Size	Length	Shape
$h(E)$	32	#6	14'-0"	—
$h_1(E)$	28	#4	13'-3"	—
$p(E)$	11	#7	38'-0"	—
$s_2(E)$	34	#4	13'-1"	□
$s_3(E)$	2	#4	13'-11"	□
$u(E)$	8	#6	10'-6"	—
$v_1(E)$	16	#5	9'-10"	—
$v_2(E)$	14	#5	16'-0"	—
$v_4(E)$	65	#5	4'-4"	—
Porous Granular Embankment, Special			Cu. Yd.	93
Structure Excavation			Cu. Yd.	92
Concrete Structures			Cu. Yd.	23.2
Concrete Encasement			Cu. Yd.	2.1
Reinforcement Bars, Epoxy Coated			Pound	2,920
Furnishing Steel Piles HP12x63			Foot	85
Driving Piles			Foot	85
Test Pile Steel HP12x63			Each	1
Geocomposite Wall Drain			Sq. Yd.	63
Concrete Headwall for Pipe Drains			Each	2
Pipe Underdrains for Structures 4"			Foot	101

NOTES:

For details of Bar Splicers, see Structural Sheet 17 of 18.
 For details of Piles and Concrete Encasement, see Structural Sheet 16 of 18.
 * See Riprap & Pile Layout, see Structural Sheet 2 of 18 for details.
 Pour steps monolithically with cap.
 All exposed edges shall have standard $\frac{3}{4}$ " chamfers, except as noted.

FILE: J:\1156000\050\013\Drawings\Struct\1156000050\013\NorthAbutment.dgn



DESIGNED - B.K.C.	REVISED -
CHECKED - M.A.C.	REVISED -
DRAWN - F.D.L.	REVISED -
CHECKED - B.K.C.	REVISED -

LASALLE COUNTY
C.H. 13 OVER TOMAHAWK CREEK
STATION 20 + 00

NORTH ABUTMENT DETAILS
STRUCTURE NO. 050-3604

STRUCTURAL SHEET NO. 15 OF 18 SHEETS

F.A.S. RTE.	SECTION	COUNTY	TOTAL SHEETS	SHEET NO.
260	10-00651-00-BR	LASALLE	51	32
WHA# 1156008		CONTRACT NO. 87466		
FED. ROAD DIST. NO. -		ILLINOIS	FED. AID PROJECT BRS-02601051	