

PROPOSED STAGE 1 TYPICAL CROSS SECTION *

STA. 15+25 TO STA. 15+75
STA. 19+25 TO STA. 19+75

* - HMA SURFACE REMOVAL BUTT JOINT
FROM STA. 15+25 TO STA. 16+10 AND
FROM STA. 18+95 TO STA. 19+75

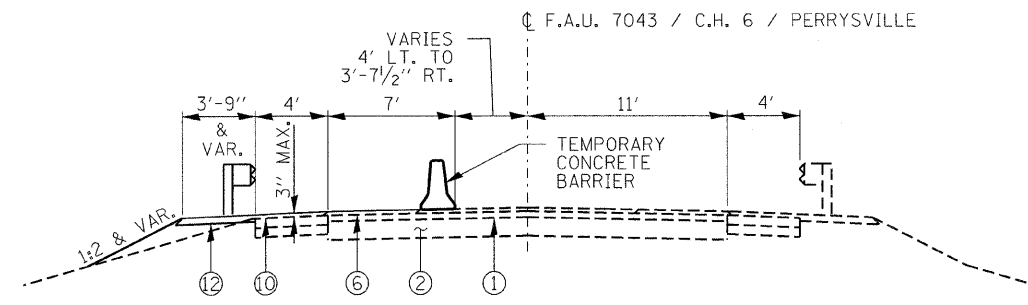

PROPOSED STAGE 2 TYPICAL CROSS SECTION

STA. 15+50 TO STA. 16+50
STA. 18+50 TO STA. 19+50

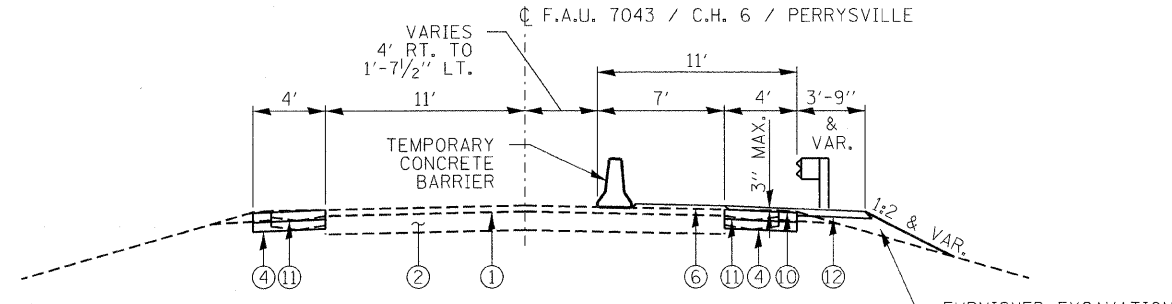

PROPOSED STAGE 1 TYPICAL CROSS SECTION

STA. 15+75 TO STA. 16+50 *
STA. 18+50 TO STA. 19+25 *

* - HMA SURFACE REMOVAL BUTT JOINT
FROM STA. 15+25 TO STA. 16+10 AND
FROM STA. 18+95 TO STA. 19+75

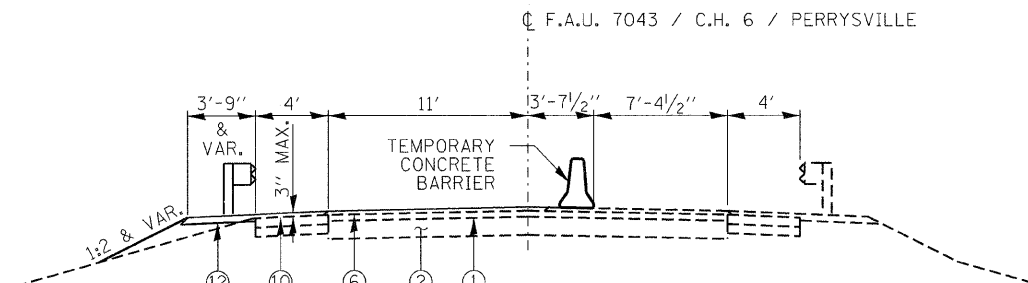

PROPOSED STAGE 2 TYPICAL CROSS SECTION

STA. 16+50 TO STA. 16+82.38
STA. 18+17.63 TO STA. 18+50

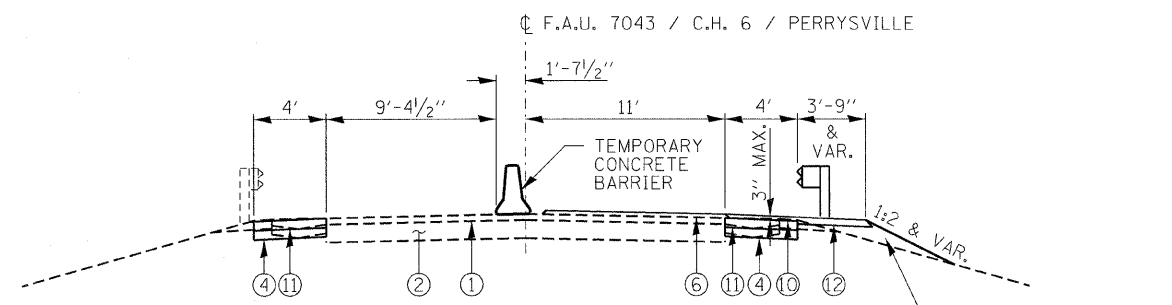

PROPOSED STAGE 1 TYPICAL CROSS SECTION

STA. 16+50 TO STA. 16+82.38
STA. 18+17.63 TO STA. 18+50

FURNISHED EXCAVATION

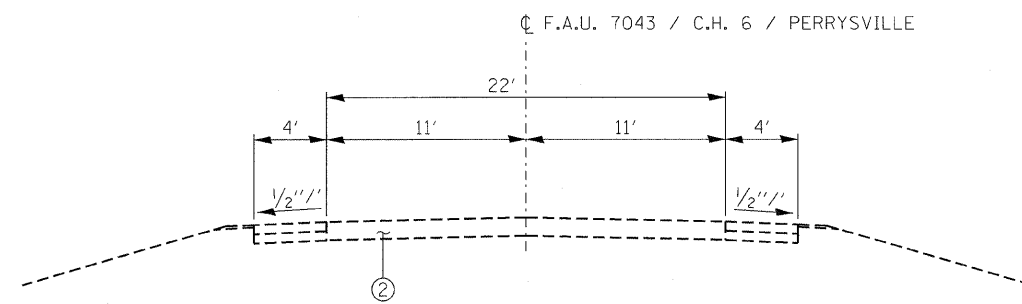

PROPOSED STAGE 2 TYPICAL CROSS SECTION

STA. 15+25 TO STA. 15+50
STA. 19+50 TO STA. 19+75

LEGEND

- ① EXIST HMA PAVEMENT (3")
- ② EXIST CONCRETE PAVEMENT (12" OR 16 1/2")
- ③ EXISTING GUTTER
- ④ SUBBASE GRANULAR MATERIAL, TYPE B (6")
- ⑤ HOT-MIX ASPHALT SURFACE COURSE, MIX "C", N50 (1.5")
- ⑥ LEVELING BINDER (MACHINE METHOD), N50
- ⑦ HOT-MIX ASPHALT SURFACE REMOVAL BUTT JOINT
- ⑧ BITUMINOUS MATERIALS (PRIME COAT)
- ⑨ AGGREGATE (PRIME COAT)
- ⑩ HOT-MIX ASPHALT SHOULDERS
- ⑪ PORTLAND CEMENT CONCRETE BASE COURSE WIDENING 6"
- ⑫ HOT-MIX ASPHALT SHOULDERS, 6"

FILE NAME = 100109-sht-stages.dgn	USER NAME =	DESIGNED - L.F.S.	REVISED -
HAMPTON, LENZINI AND RENWICK, INC. 3365 STEVENSON DRIVE, SUITE 201 SPRINGFIELD, ILLINOIS 62708	PLOT SCALE =	DRAWN - T.W.K.	REVISED -
ILLINOIS PROFESSIONAL DESIGN FIRM LS / PE / SE CORP. 184.000959	PLOT DATE = 2/9/2012	CHECKED - S.W.M.	REVISED -
		DATE - 02/09/12	REVISED -

**STATE OF ILLINOIS
VERMILION COUNTY HIGHWAY DEPARTMENT**

STAGE CONSTRUCTION TYPICAL SECTIONS C.H. 6 / PERRYSVILLE ROAD			
SCALE:	SHEET NO.	OF SHEETS	STA. TO STA.

F.A.U.	SECTION	COUNTY	TOTAL SHEETS	SHEET NO.
7043	09-00171-00-BR	VERMILION	66	10
CONTRACT NO. 91449				
ILLINOIS FED. AID PROJECT				