

INDEX OF SHEETS

SHEET NO.	DESCRIPTION
1	TITLE SHEET & SUMMARY OF QUANTITIES
2	PLAN & PROFILE, TYPICAL SECTIONS, GENERAL NOTES & STONE RIPRAP DITCH DESIGN
3-4	ROADWAY CROSS SECTIONS
5-14	BRIDGE DESIGN

THE FOLLOWING STANDARDS ARE A PART OF THESE PLANS AND ARE INCLUDED IN THE PROPOSAL:

000001-06	STANDARD SYMBOLS, ABBREVIATIONS & PATTERNS
280001-06	TEMPORARY EROSION CONTROL SYSTEMS
701901-02	TRAFFIC CONTROL DEVICES
B.L.R. 21-9	TYPICAL APPLICATION OF TRAFFIC CONTROL DEVICES FOR CONSTRUCTION ON RURAL LOCAL HIGHWAYS
B.L.R. 22-7	TYPICAL APPLICATION OF TRAFFIC CONTROL DEVICES FOR CONSTRUCTION ON RURAL LOCAL HIGHWAYS (TWO-LANE TWO-WAY RURAL TRAFFIC) (ROAD CLOSED TO THRU TRAFFIC)
B.L.R. 23-4	TRAFFIC BARRIER TERMINAL TYPE 1
B.L.R. 27-1	TRAFFIC BARRIER TERMINAL TYPE 5A

SUMMARY OF QUANTITIES

CODE NO.	ITEM	UNIT	QUANTITY
20100110	TREE REMOVAL (6 TO 15 UNITS DIAMETER)	UNIT	6.00
20100210	TREE REMOVAL (OVER 15 UNITS DIAMETER)	UNIT	30.00
20200100	EARTH EXCAVATION	CU YD	175.00
20300100	CHANNEL EXCAVATION	CU YD	377.00
20400800	FURNISHED EXCAVATION	CU YD	349.00
28000305	TEMPORARY DITCH CHECKS	FOOT	28.00
28100807	STONE DUMPED RIPRAP, CLASS A4	TON	360.00
40200800	AGGREGATE SURFACE COURSE, TYPE B	TON	330.00
50100100	REMOVAL OF EXISTING STRUCTURES	EACH	1.00
50300225	CONCRETE STRUCTURES	CU YD	26.20
50300280	CONCRETE ENCASEMENT	CU YD	2.80
50400505	PRECAST PRESTRESSED-CONCRETE DECK BEAMS (27" DEPTH)	SQ FT	1440.00
50800105	REINFORCEMENT BARS	POUND	2680.00
▲ 50900205	STEEL RAILING, TYPE S1	FOOT	125.00
51201400	FURNISHING STEEL PILES 10X42	FOOT	440.00
51202305	DRIVING PILES	FOOT	440.00
51500100	NAME PLATES	EACH	1.00
▲ 63100075	TRAFFIC BARRIER TERMINAL, TYPE 5A	EACH	2.00
*67100100	MOBILIZATION	L SUM	1.00
*X2501000	SEEDING, CLASS 2 (SPECIAL)	ACRE	0.50
*Z0068900	STONE LINED DITCH	TON	103.00
▲ *LR631020	TRAFFIC BARRIER TERMINAL, TYPE 1	EACH	2.00

▲ SPECIALTY ITEMS

DESIGN DESIGNATION:
 DESIGN SPEED: 30 MPH
 HIGHWAY CLASS - LOCAL ROAD
 EXISTING STRUCTURE NO.: 097-3098
 PROPOSED STRUCTURE NO.: 097-2775
 CURRENT A.D.T. = 50
 CONTRACT NO. 99474

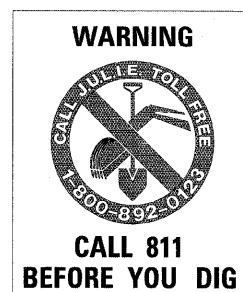

STATE OF ILLINOIS
DEPARTMENT OF TRANSPORTATION
PLANS FOR PROPOSED
FEDERAL AID – H.B.P. PROJECT

T.R. 251 WHITE COUNTY SECTION 09-08140-00-BR

PROJECT NO. BROS-193(054) JOB NO. C-99-517-10

CONTRACT # 99474 BEAR CREEK

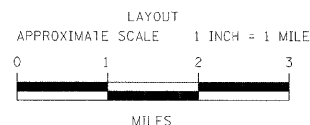
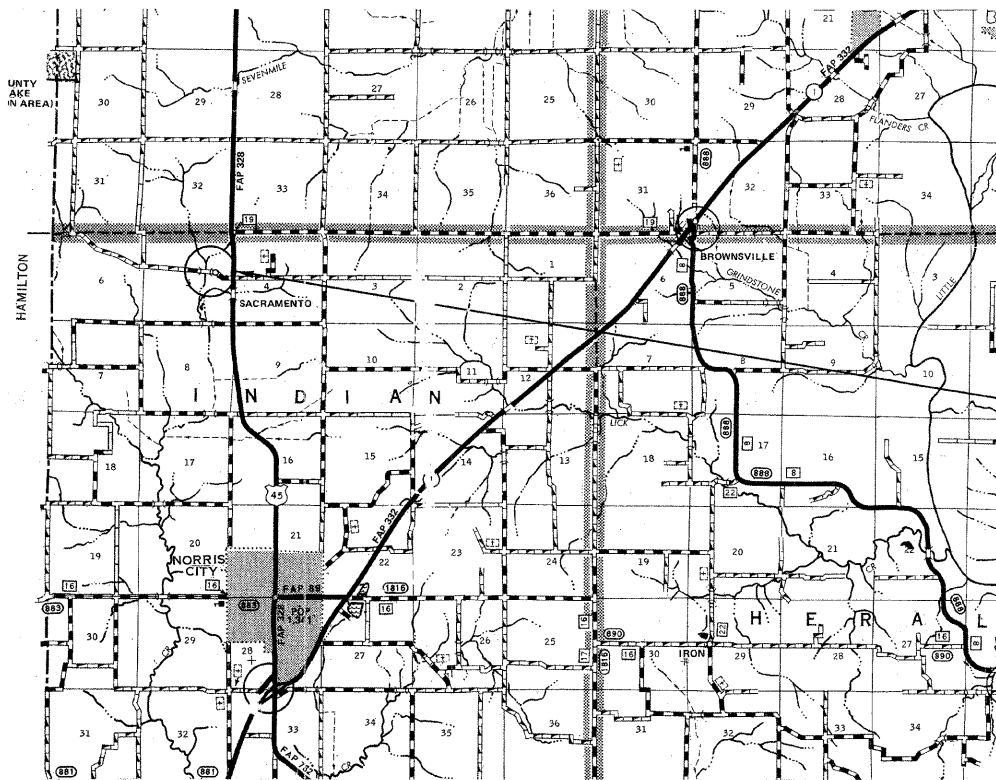

GROSS LENGTH	555.00 FT	0.105 MILES
OMISSIONS	0.00 FT	0.000 MILES
NET LENGTH	555.00 FT	0.105 MILES

PLAN	1" = 50'	
PROFILE	1" = 50'	
PROFILE VERT.	1" = 5'	
CROSS SECTION	1" = 5'	

SECTION 09-08140-00-BR
 BEGINS STATION 2+15

STATION 5+00, STRUCTURE NO. 097-3275
 A 60' LONG SINGLE SPAN PRESTRESSED CONCRETE DECK BEAM BRIDGE (27" DEPTH), 24" ROADWAY, 0.00% GRADE, 10° RT. FWD. SKEW, 3.0% S.E. RT.

SECTION 09-08140-03-BR
 ENDS STATION 7+70

STATE OF ILLINOIS
 DEPARTMENT OF TRANSPORTATION

APPROVED February 15th, 2012
Brian Ray
 COUNTY ENGINEER

PASSED FEBRUARY 23, 2012
Dennis W. Hillman
 ENGINEER OF LOCAL ROADS AND STREETS

RELEASING FOR BID
 BASED ON LIMITED
 REVIEW: FEBRUARY 23, 2012
Omer Osman
 OMER OSMAN, P.E.
 DEPUTY DIRECTOR OF HIGHWAYS
 REGION FIVE ENGINEER

TR	SECTION	COUNTY	TOTAL SHEETS	SHEET NO.
251	09-08140-00-BR	WHITE	14	1

FED. ROAD DIST. NO. 9 ILLINOIS
 PROJECT # BROS-193(054)
 JOB # C-99-517-10

FED. AID PROJECT
 CONTRACT # 99474
 BEAR CREEK

PHONE: (618)-262-8651
 FAX: (618)-263-3327
 LEC JOB # H111006WH

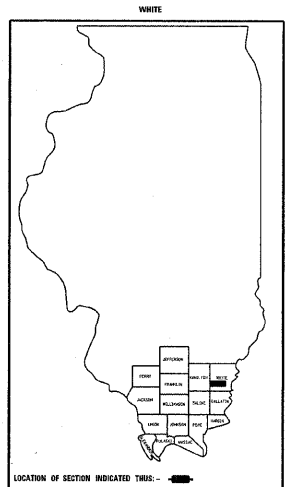

323 W. 3RD. ST.
 P.O. BOX 160
 MT. CARMEL, IL 62863

405 W. STATE ST.
 SUITE 1
 PRINCETON, IN 47670

PHONE: (812)-386-7611
 FAX: (812)-385-2812



PROFESSIONAL DESIGN FIRM
 LAND SURVEY &
 PROFESSIONAL ENGINEERING CORPORATION

184-000887
 (62-032435) (35-002769)

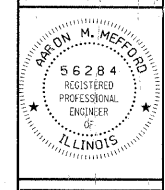

AARON M. MEFFORD
 NAME
Aaron Mefford
 SIGNATURE
 DATE
 2-15-12
 11-30-13 EXPIRES

T.R. 251
 OVER BEAR CREEK
 WHITE COUNTY, ILLINOIS

SHEET TITLE:
 TITLE SHEET

SCALE: VARS

BY: AMM
 DATE: 2/9/12
 REV:

1 OF 14 SHEETS

SHEET NO.
 1

GENERAL NOTES:

THIS SECTION SHALL BE CONSTRUCTED IN ACCORDANCE WITH THE PLANS, SPECIAL PROVISIONS AND "STANDARD SPECIFICATIONS FOR ROAD AND BRIDGE CONSTRUCTION", ADOPTED JANUARY 1, 2012.

THE WORK INVOLVED ON THIS SECTION CONSISTS OF THE REMOVAL OF THE EXISTING STRUCTURE, THE CONSTRUCTION OF A 60 FOOT LONG SINGLE SPAN PRECAST, PRESTRESSED CONCRETE DECK BEAM BRIDGE, EARTH APPROACHES, AGGREGATE SURFACE COURSE AND OTHER MISCELLANEOUS ITEMS NECESSARY TO COMPLETE THIS SECTION.

ALL ELEVATIONS ARE BASED ON U.S.G.S. MEAN SEA LEVEL DATUM.

IT SHALL BE THE CONTRACTOR'S RESPONSIBILITY TO CONTACT ALL THE UTILITIES, AFFECTING THE PROJECT, PRIOR TO CONSTRUCTION.

NOTE: CONSTRUCTION TRANSITION
STA. 2+15 TO STA 2+65
STA 7+20 TO STA 7+70

ALL QUANTITIES ARE INCLUDED IN THE PROPOSAL

TYPICAL CROSS SECTION PROPOSED

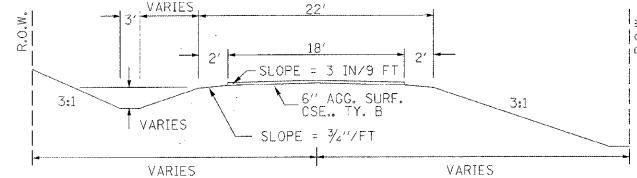

TYPICAL CROSS SECTION EXISTING

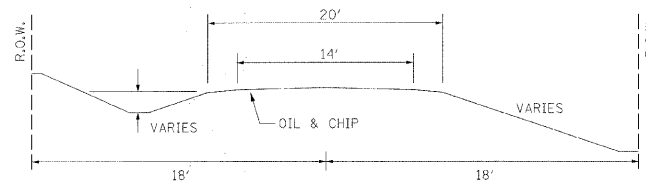

NOTE: CONSTRUCT SPECIAL DITCH

STA 2+50 TO STA 4+75 LT
STA 3+00 TO STA 4+75 RT
STA 5+10 TO STA 7+00 LT
STA 5+25 TO STA 7+50 RT

NOTE: CONSTRUCT STONE LINED DITCH

STA 4+25 TO STA 4+75 LT (0.62 TON/LIN FT)
STA 4+50 TO STA 4+75 RT (0.62 TON/LIN FT)
STA 5+10 TO STA 5+75 LT (0.62 TON/LIN FT)
STA 5+25 TO STA 5+50 RT (0.62 TON/LIN FT)
103 TON STONE LINED DITCH ALLOWED IN PROPOSAL.

SEE STONE LINED DITCH DETAIL.

UTILITIES:
J.U.L.T.E. 1-800-892-0123

WAYNE-WHITE ELECTRIC
1-618-842-2196

STONE LINED DITCH DESIGN

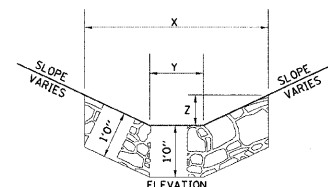
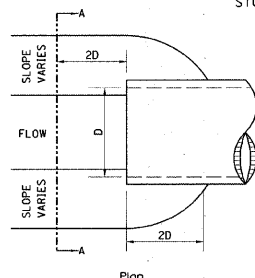

NOTE:

BOTTOM OF DITCH	SLOPE			
2 FT	X = 5 FT	6 FT	8 FT	
	Y = 2 FT	2 FT	2 FT	
	Z = 1 FT	1 FT	1 FT	
	0.40	0.48	0.62	TON/LIN. FT

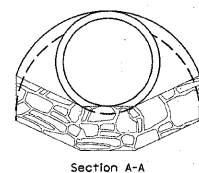

NOTE: FOR PLACEMENT, QUALITY GRADATION AND OTHER MISCELLANEOUS REQUIREMENTS FOR STONE LINED DITCH-SEE SPECIAL PROVISIONS.

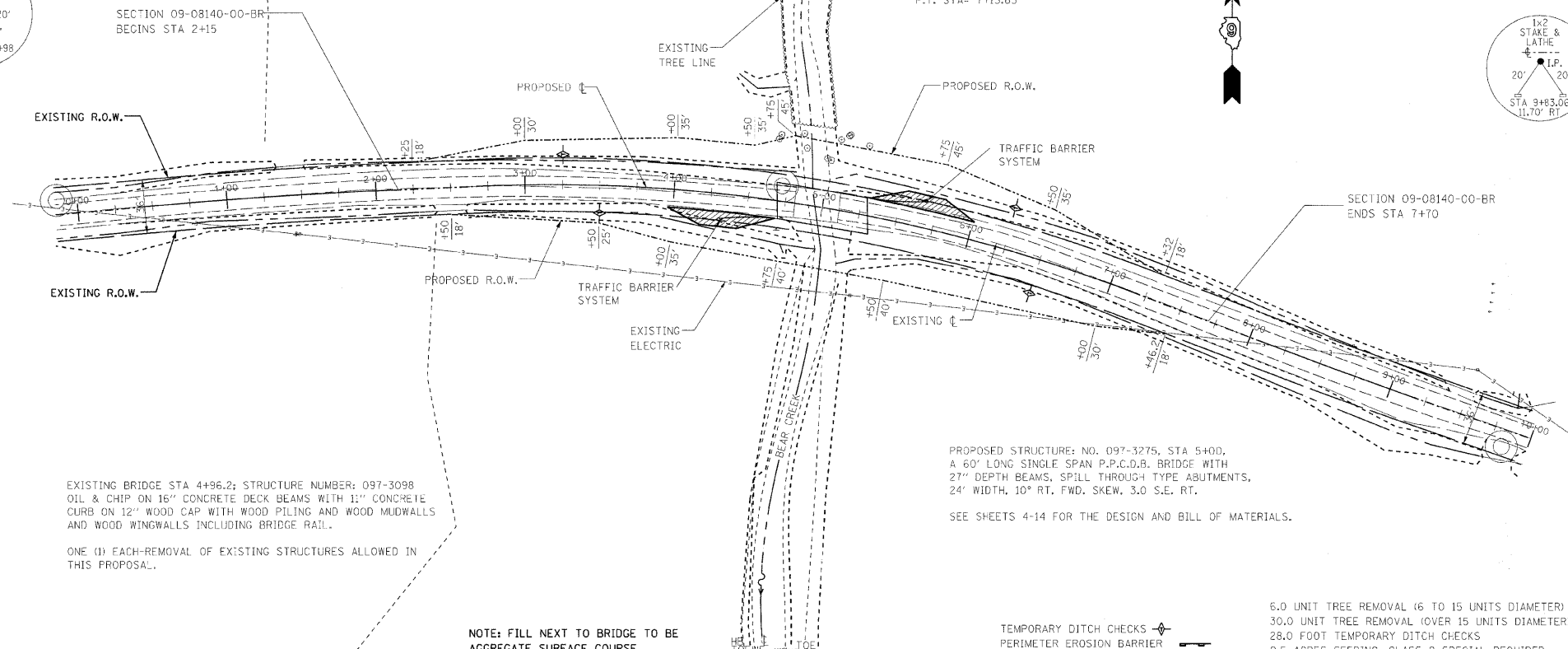
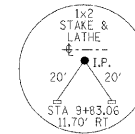
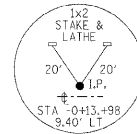

EXISTING BRIDGE STA 4+96.2; STRUCTURE NUMBER: 097-3098
OIL & CHIP ON 16" CONCRETE DECK BEAMS WITH 1" CONCRETE CURB ON 12" WOOD CAP WITH WOOD PILING AND WOOD MUDWALLS AND WOOD WINGWALLS INCLUDING BRIDGE RAIL.

ONE (1) EACH-REMOVAL OF EXISTING STRUCTURES ALLOWED IN THIS PROPOSAL.

NOTE: FILL NEXT TO BRIDGE TO BE AGGREGATE SURFACE COURSE

PROPOSED STRUCTURE: NO. 097-3275, STA 5+00, A 60' LONG SINGLE SPAN P.P.C.D.B. BRIDGE WITH 27" DEPTH BEAMS, SPILL THROUGH TYPE ABUTMENTS, 24' WIDTH, 10° RT. SKEW, 3.0 S.E. RT.

SEE SHEETS 4-14 FOR THE DESIGN AND BILL OF MATERIALS.

TEMPORARY DITCH CHECKS
PERIMETER EROSION BARRIER

6.0 UNIT TREE REMOVAL (6 TO 15 UNITS DIAMETER)
30.0 UNIT TREE REMOVAL (OVER 15 UNITS DIAMETER)
28.0 FOOT TEMPORARY DITCH CHECKS
0.5 ACRES SEEDING, CLASS 2 SPECIAL REQUIRED

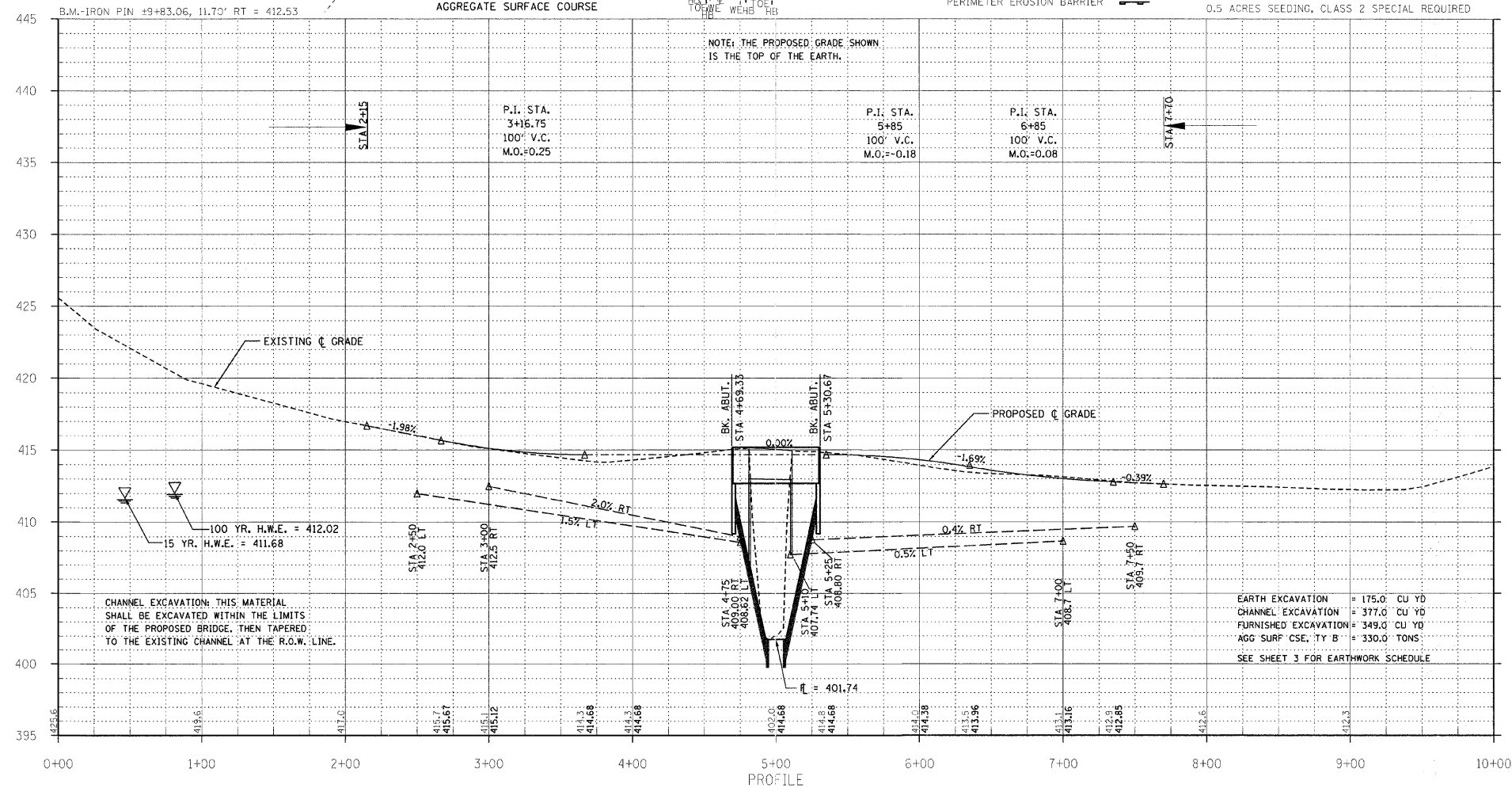

CHANNEL EXCAVATION: THIS MATERIAL SHALL BE EXCAVATED WITHIN THE LIMITS OF THE PROPOSED BRIDGE, THEN TAPERED TO THE EXISTING CHANNEL AT THE R.O.W. LINE.

EARTH EXCAVATION = 175.0 CU YD
CHANNEL EXCAVATION = 377.0 CU YD
FURNISHED EXCAVATION = 349.0 CU YD
AGG SURF CSE, TY B = 330.0 TONS
SEE SHEET 3 FOR EARTHWORK SCHEDULE

TR	SECTION	COUNTY	TOTAL SHEETS	SHEET NO.
251	09-08140-00-BR	WHITE	14	2
FED. ROAD DIST. NO. 9 ILLINOIS		BEAR CREEK		
PROJECT # BR05-1930541		CONTRACT # 99474		
LEC JOB # HILL006WH				

323 W. 3RD ST.
P.O. BOX 160
MT. CARMEL, IL
62863

PHONE:
(618) 262-8651
FAX:
(618)-263-3327

405 W. STATE ST
SUITE 1
PRINCETON, IN
47670

PHONE:
(812)-386-7611
FAX:
(812)-385-2812



PROFESSIONAL DESIGN FIRM
LAND SURVEY & PROFESSIONAL ENGINEERING CORPORATION
184-000887
(62-032435)(35-002789)

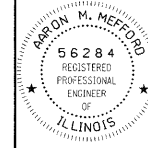

AARON M. MEFFORD
NAME

SIGNATURE

DATE
2-15-12

11-30-13
EXPIRES

TOWNSHIP ROUTE 251
OVER BEAR CREEK
WHITE COUNTY, ILLINOIS

SHEET TITLE:

PLAN & PROFILE

SCALE: VARIES

BY: AMM

DATE: 2/9/12

REV:

2 OF 14

SHEETS

SHEET NO.

2

C = 8.8
F = 94.0

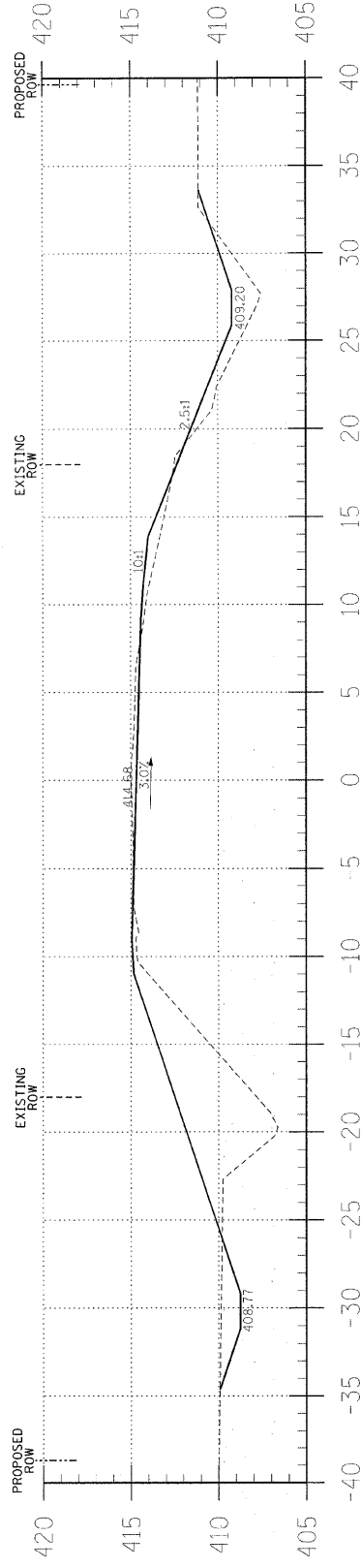

4+65

C = 14.3
F = 75.1

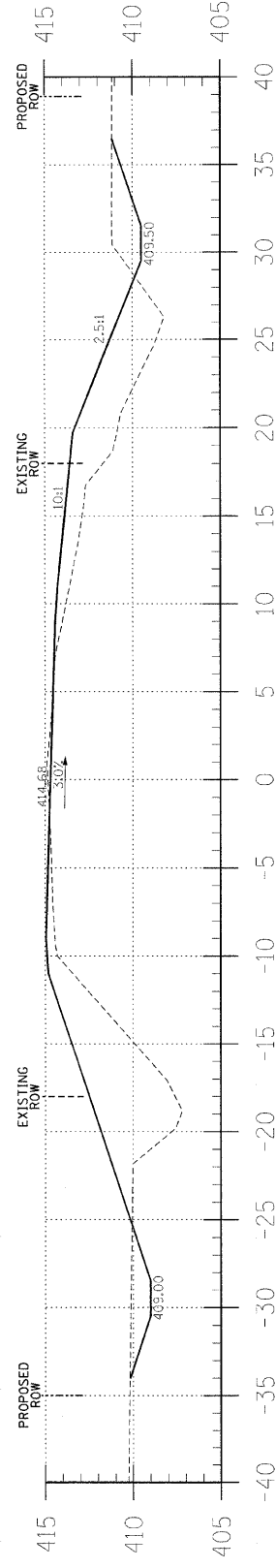

4+50

C = 9.8
F = 53.9

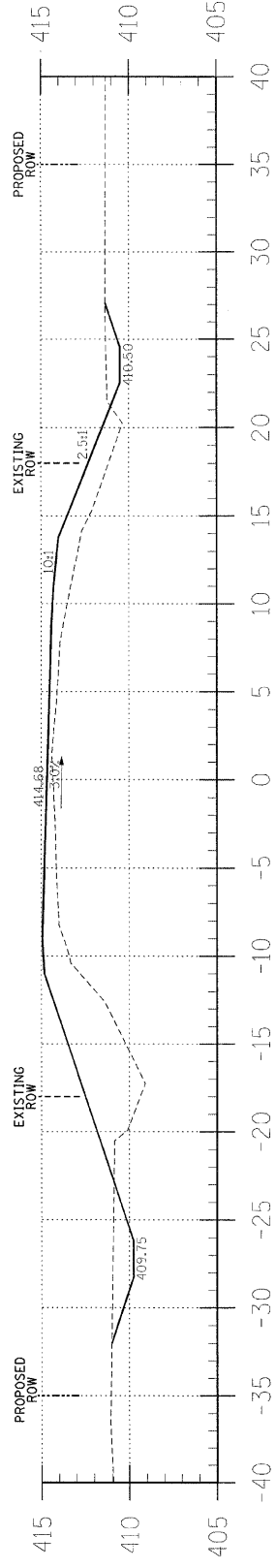

4+00

C = 8.4
F = 28.6

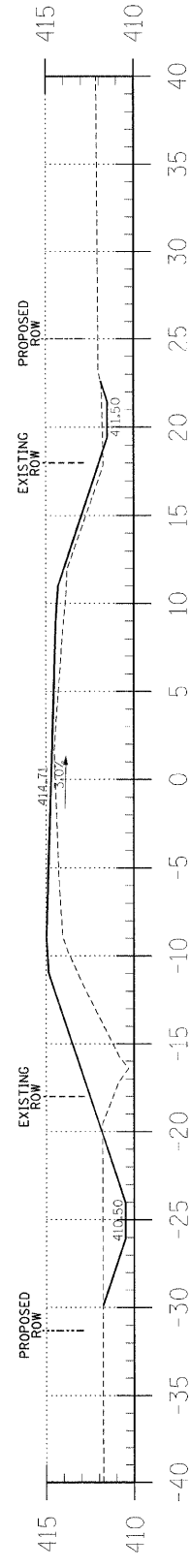

3+50

C = 10.9
F = 16.5

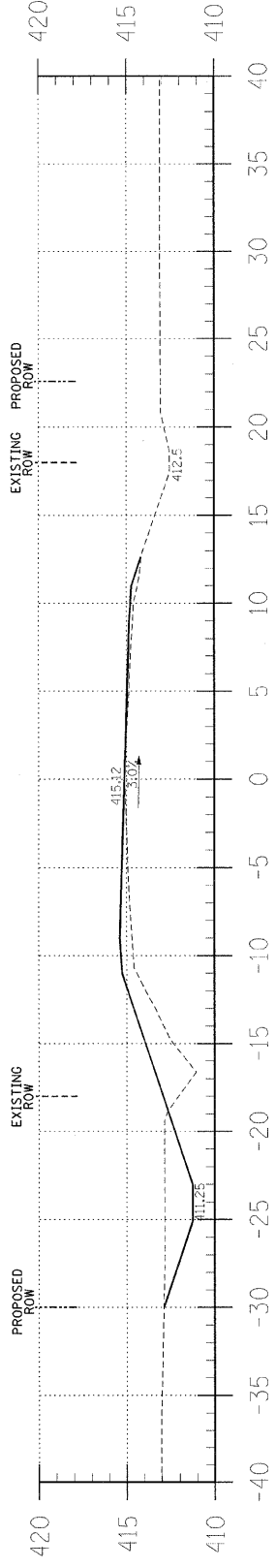

3+00

C = 0.0
F = 4.9

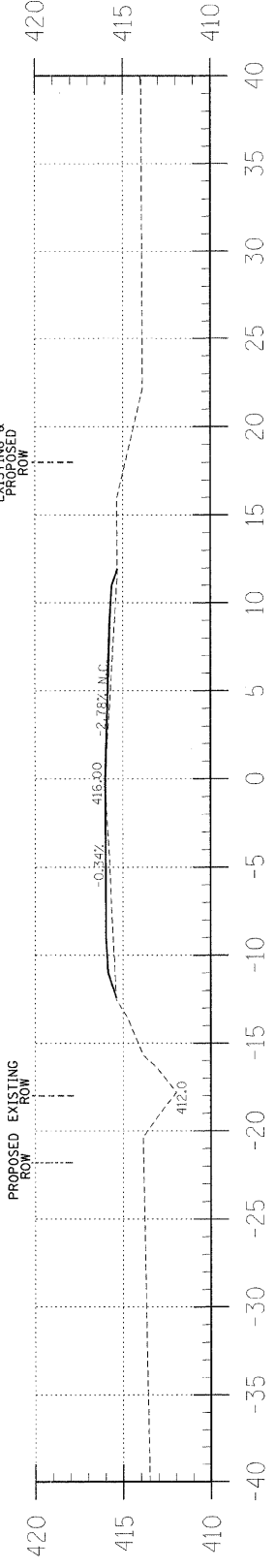

2+50

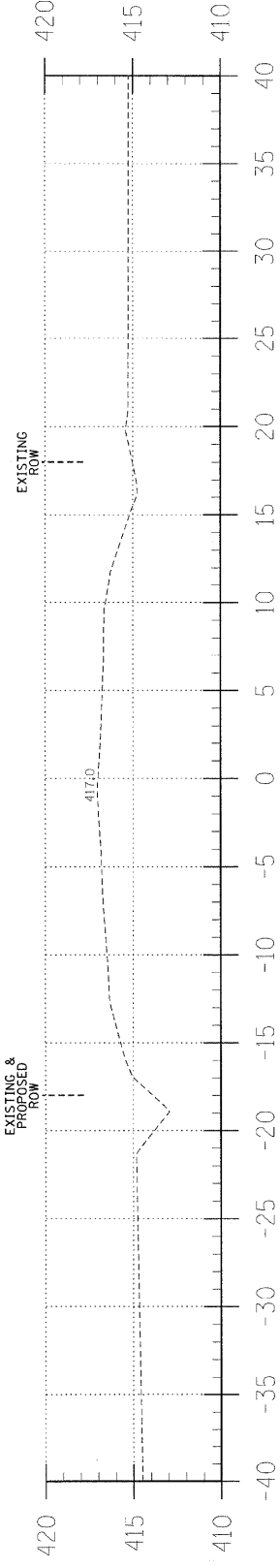

2+00

EARTHWORK SCHEDULE

LOCATION	EARTH EXCAVATION	CHANNEL EXCAVATION	ESTIMATED UNSUITABLE MATERIAL	SUITABLE MATERIAL ADJUSTED FOR SHRINKAGE	EMBANKMENT	EARTHWORK BALANCE WASTE (+) OR SHORTAGE (-)
	CUBIC YARD	CUBIC YARD	CUBIC YARD	CUBIC YARD	CUBIC YARD	CUBIC YARD
STA 0+00 TO 4+65.3	74.6	0.0	0.0	56.0	308.0	-252.0
STA 4+65.3 TO 5+30.7	0.0	377.1	186.5	141.4	0.0	141.4
STA 5+30.7 TO 10+00	100.0	0.0	0.0	75.0	312.9	-237.9
TOTAL	174.6	377.1	186.5	272.4	620.9	-348.5

TR	SECTION	COUNTY	TOTAL SHEETS	SHEET NO.
251	09-08140-00-BR	WHITE	14	3
FED. ROAD DIST. NO. 9 ILLINOIS		FED. AID PROJECT		
PROJECT# BROS-19310541		CONTRACT# 99474		
JOB NO. C-99-517-10		BEAR CREEK		

323 W. 3RD ST.
P.O. BOX 160
MT. CARMEL, IL
62863
PHONE:
(618)-262-8651
FAX:
(618)-263-3327

405 W STATE ST.
SUITE 1
PRINCETON, IN
47670
PHONE:
(812)-386-7611
FAX:
(812)-385-2812



PROFESSIONAL DESIGN FIRM
LAND SURVEY &
PROFESSIONAL ENGINEERING CORPORATION
184-000887
(62-032435)(35-002769)

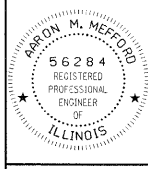

AARON M. MEFFORD
NAME
Aaron M. Mefford
SIGNATURE
DATE
2-15-12
11-30-13
EXPIRES

TOWNSHIP ROUTE 251
OVER BEAR CREEK
WHITE COUNTY, ILLINOIS

SHEET TITLE:
CROSS-SECTIONS
SCALE: 1" = 5'
BY: AMM
DATE: 2/12
REV:
3 OF 14 SHEETS
SHEET NO. 3

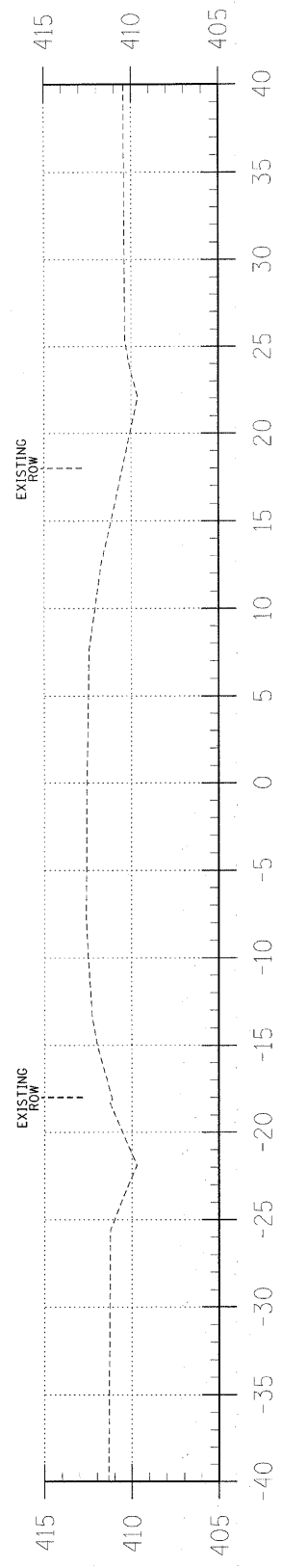

8+00

C = 0.6
F = 1.6

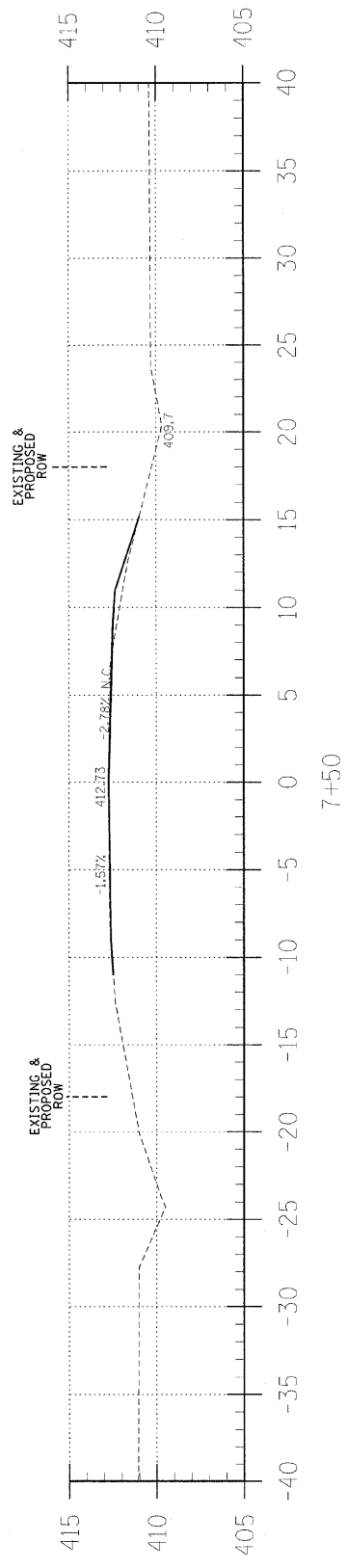

7+50

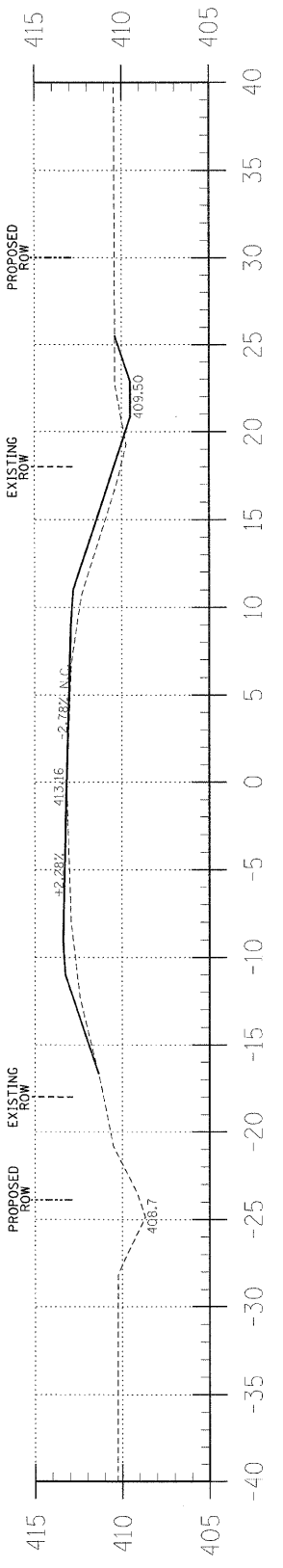

C = 2.9
F = 11.0

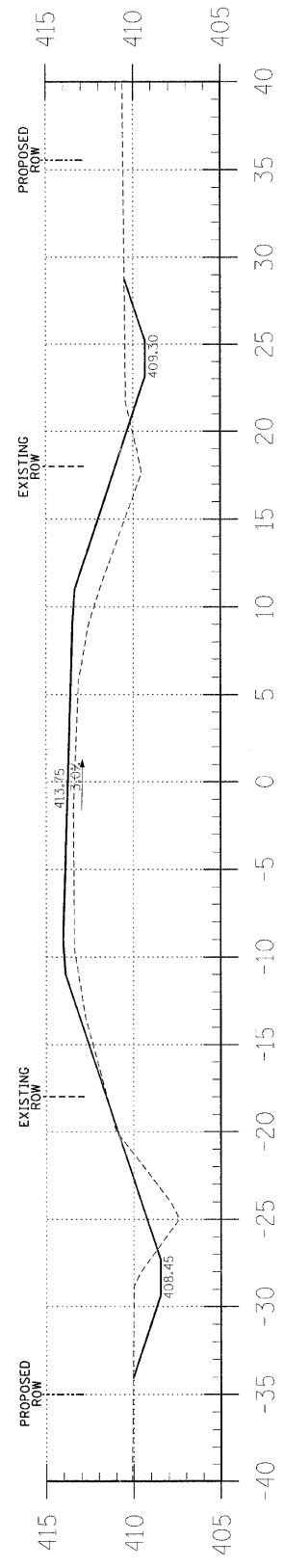

6+50

C = 12.3
F = 34.0

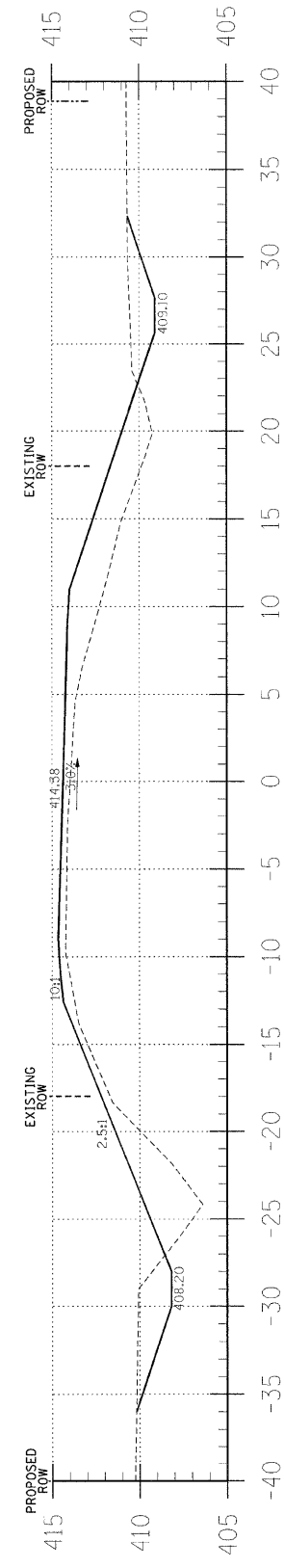

6+00

C = 18.2
F = 53.8

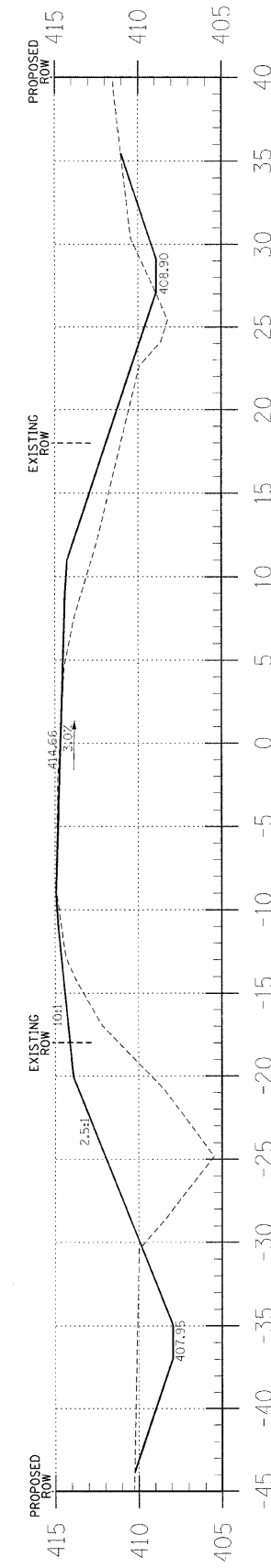

5+50

C = 22.6
F = 81.3

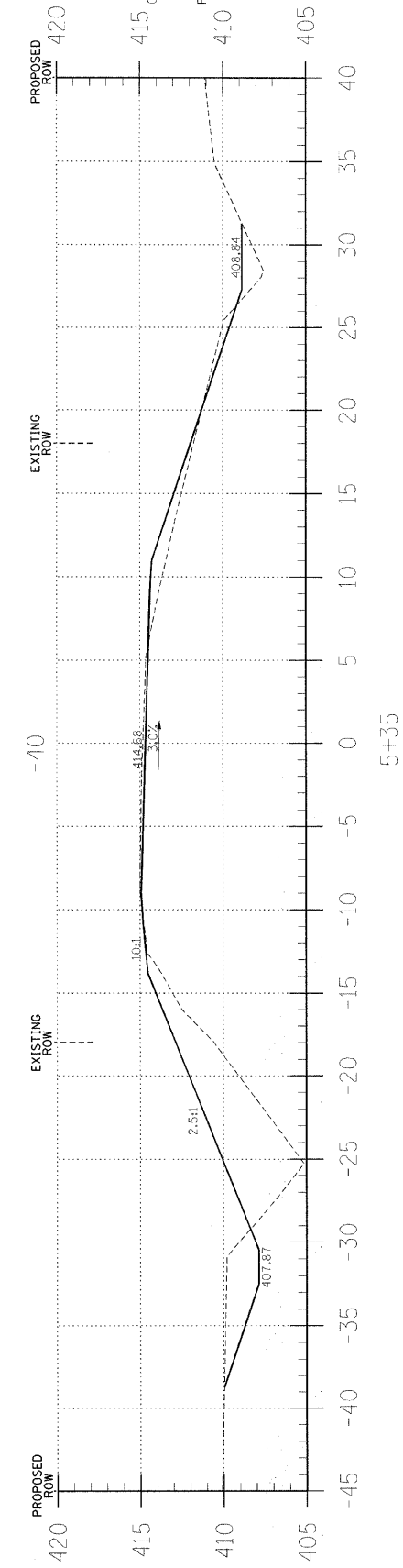

5+35

C = 14.5
F = 51.0

TR	SECTION	COUNTY	TOTAL SHEETS	SHEET NO.
251	09-08140-00-BR	WHITE	14	4
FED. ROAD DIST. NO. 9 ILLINOIS		FED. AID PROJECT		
PROJECT# BROS-1931054		CONTRACT# 99474		
JOB NO. C-99-517-10		BEAR CREEK		
LEC JOB # H111006WH				

323 W. 3RD ST.
P.O. BOX 160
MT. CARMEL, IL
62863
PHONE:
(618)-262-8651
FAX:
(618)-263-3327

405 W. STATE ST.
SUITE 1
PRINCETON, IN
47370
PHONE:
(812)-386-7611
FAX:
(812)-385-2812



PROFESSIONAL DESIGN FIRM
LAND SURVEY & PROFESSIONAL ENGINEERING CORPORATION
184-00687
(62-032435)(35-002769)



AARON M. MEFFORD
NAME
Signature
DATE
2-15-12
11-30-13 EXPIRES

TOWNSHIP ROUTE 251
OVER BEAR CREEK
WHITE COUNTY, ILLINOIS

SHEET TITLE:

CROSS-SECTIONS

SCALE: 1" = 5'
BY: AMM
DATE: 2/9/12
REV:

4 OF 14 SHEETS

SHEET NO. 4

BENCHMARK:

EXISTING STRUCTURE: Single span concrete deck bridge on timber abutments and wingwalls, 28' fc-fc. abuts.; 21.0' o-o. deck; Str. No. 097-3098
Structure closed to traffic during construction.

No Salvage

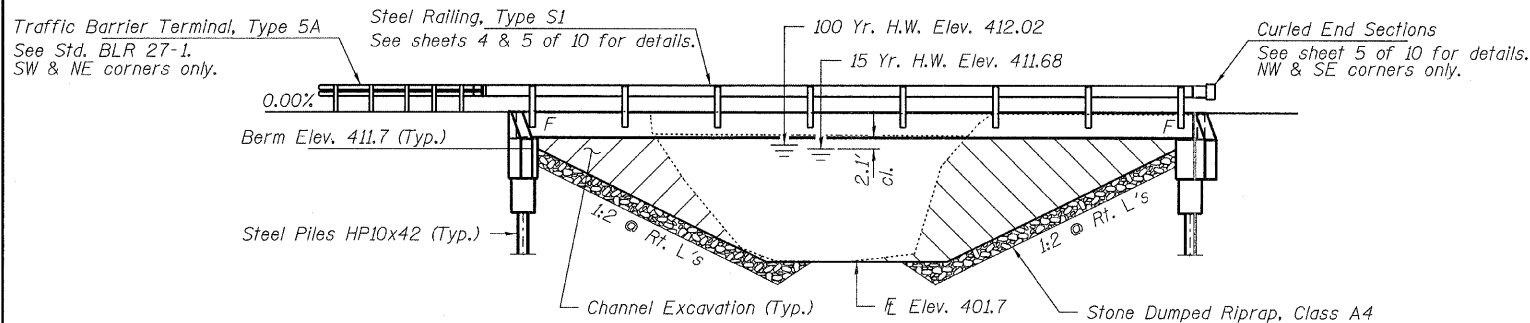

ELEVATION

BEAR CREEK
BUILT 201 BY
WHITE COUNTY
SEC. 09-08140-00-BR
INDIAN CREEK ROAD DISTRICT
STR. NO. 097-3275
LOADING HL-93

NAME PLATE
See Std. 515001

GENERAL NOTES

Layout of the slope protection system may be varied to suit ground conditions in the field as directed by the Engineer.
Reinforcement bars shall conform to the requirements of ASTM A 706 Gr 60. See Special Provisions.
Excavation required to construct the Abutments shall be included in the cost of Concrete Structures. No additional compensation will be allowed for Structure Excavation.
All proposed construction activities shall be in accordance with Nationwide Permit number 14 of the Department of the Army authorized under Section 404 of the Clean Water Act.
The IEPA has issued Section 401 Water Quality Certification for this activity. See Special Provisions for conditions.

INDEX OF STRUCTURE SHEETS

1. General Plan & Elevation
2. 27"x48" PPC Deck Beam
3. 27"x48" PPC Deck Beam Details
4. Superstructure Details
5. Steel Railing, Type S1
6. West Abutment
7. East Abutment
8. HP Pile Details
- 9-10. Boring

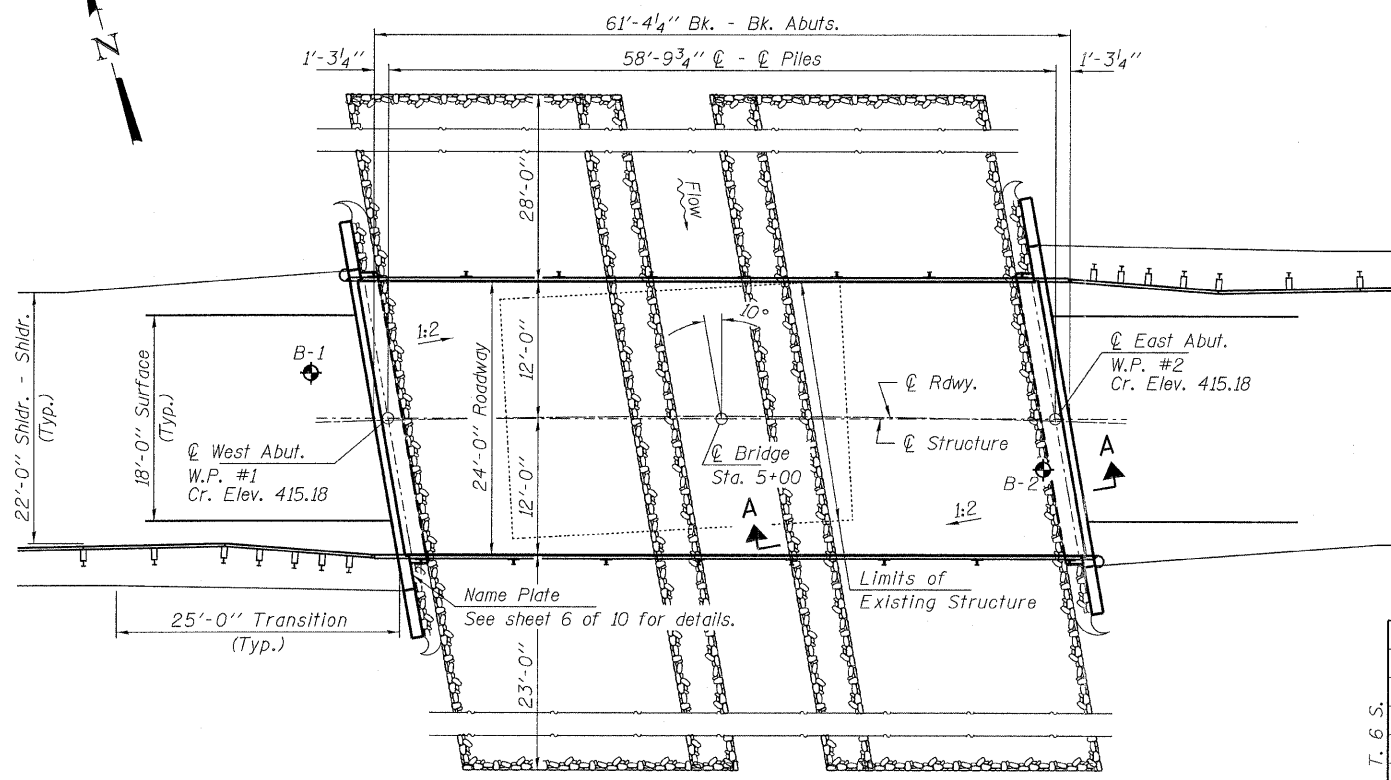

PLAN

DESIGN SCOUR ELEVATION TABLE

Design Scour Elevation (ft.)	S. Abut.	N. Abut.
	409.1	409.1

LOCATION SKETCH

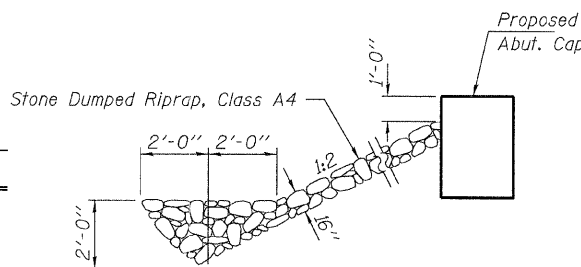
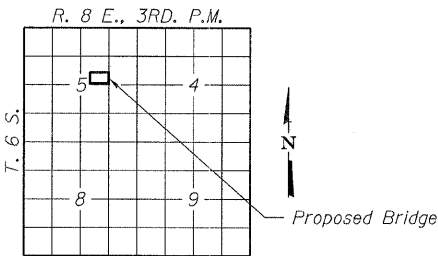

SECTION A-A

Note: See Special Provisions for Stone Dumped Riprap, Class A4.

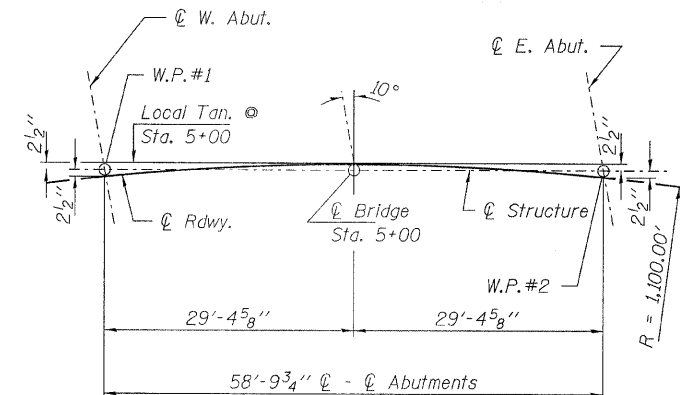

OFFSET SKETCH

DESIGN STRESSES

FIELD UNITS

f'c = 3,500 psi
fy = 60,000 psi (Reinf.)

PRECAST PRESTRESSED UNITS

f'c = 6,000 psi
f'cl = 5,000 psi
fpu = 270,000 psi (1/2" low lax. strands)
fpbt = 201,960 psi (1/2" low lax. strands)
fy = 60,000 psi (Reinf.)

LOADING HL-93

Design Specifications: 2010 AASHTO LRFD with all applicable Interims.
50#/Sq. Ft. included in dead load for future wearing surface.

SEISMIC DATA

Seismic Performance Zone (SPZ) = 3
Design Spectral Acceleration at 1.0 sec. (S_{D1}) = 0.309g
Design Spectral Acceleration at 0.2 sec. (S_{D5}) = 0.733g
Soil Site Class = D

WATERWAY INFORMATION

Flood	Freq. Yr.	Q C.F.S.	Opening Sq. Ft.		Natural Head - Ft.		Headwater El.	
			Exist.	Prop.	H.W.E. Exist.	Prop.	Exist.	Prop.
Design	15	1467	236	344	411.68	-	-	-
Base	100	2580	246	363	412.02	2.28	0.33	414.3
Max. Calc.	500							415.3

I certify that to the best of my knowledge, information and belief, this bridge design is structurally adequate for the design loading shown on the plans. The design is an economical one for the style of structure and complies with requirements of the current "AASHTO LRFD Specifications."

Steven Megginson 2/10/2012
ILLINOIS STRUCTURAL NO. 081-6064

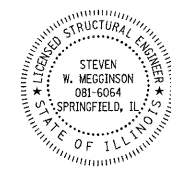

Expires 11-30-2012

TOTAL BILL OF MATERIAL

ITEM	UNIT	SUPER	SUB	TOTAL
Channel Excavation	Cu. Yd.			377
Stone Dumped Riprap, Class A4	Ton			360
Removal of Existing Structures	Each			1
Concrete Structures	Cu. Yd.		26.2	26.2
Concrete Encasement	Cu. Yd.		2.8	2.8
Precast Prestressed Concrete Deck Beams (27" Depth)	Sq. Ft.	1,440		1,440
Reinforcement Bars	Pound		2,680	2,680
Steel Railing, Type S1	Foot	125		125
Furnishing Steel Piles HP10x42	Foot		440	440
Driving Piles	Foot		440	440
Name Plates	Each			1

FILE NAME = 118871-shr-brIDGE.dgn	USER NAME =
HAMPTON, LENZINI AND RENWICK, INC.	DESIGNED - A.S.L.
3605 STEVENSON DRIVE, SUITE 201	CHECKED - S.W.M.
SPRINGFIELD, ILLINOIS 62703	DRAWN - D.A.B.
ILLINOIS PROFESSIONAL DESIGN FIRM	CHECKED - S.W.M.
LS / PE / SE CORP. 184-00999	REVISOR -
PLOT SCALE =	REVISOR -
PLOT DATE = 2/10/2012	REVISOR -

DESIGNED - A.S.L.	REVISOR -
CHECKED - S.W.M.	REVISOR -
DRAWN - D.A.B.	REVISOR -
CHECKED - S.W.M.	REVISOR -

STATE OF ILLINOIS
WHITE COUNTY HIGHWAY DEPARTMENT

GENERAL PLAN & ELEVATION
STRUCTURE NO. 097-3275
SHEET NO. 1 OF 10 SHEETS

T.R.	SECTION	COUNTY	TOTAL SHEETS	SHEET NO.
251	09-08140-00-BR	WHITE	14	5
INDIAN CREEK ROAD DISTRICT			CONTRACT NO. 99474	
ILLINOIS FED. AID PROJECT				

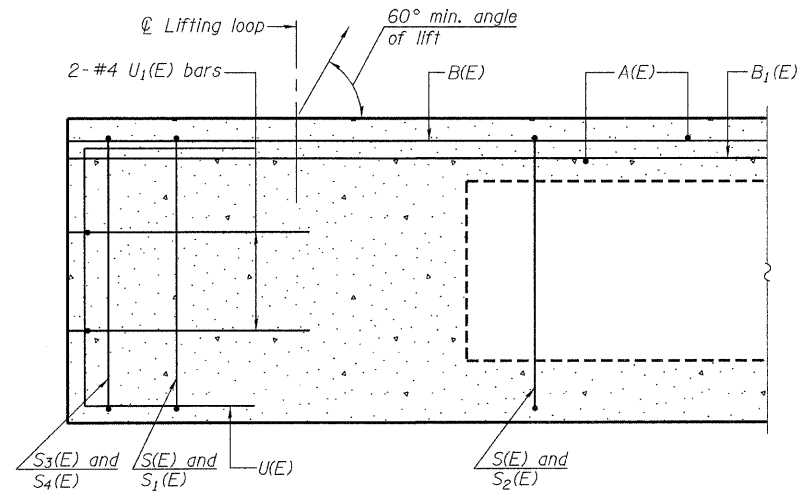

SECTION A-A

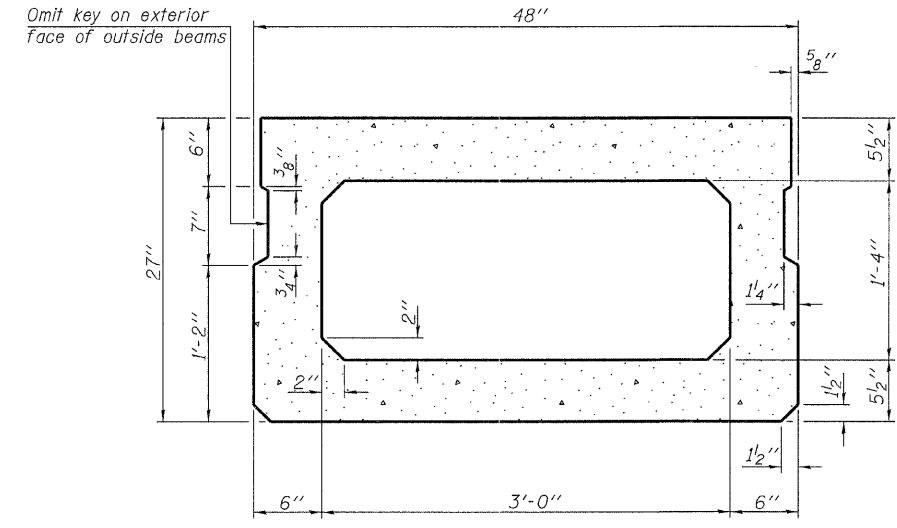

SECTION B-B
(Showing dimensions)

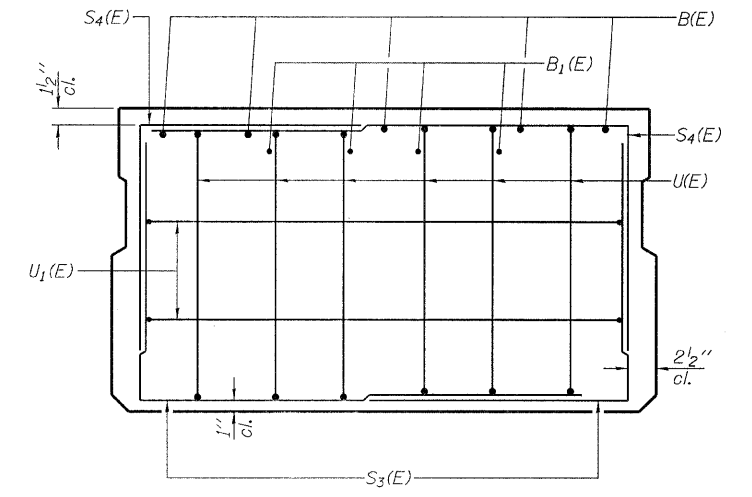

VIEW C-C

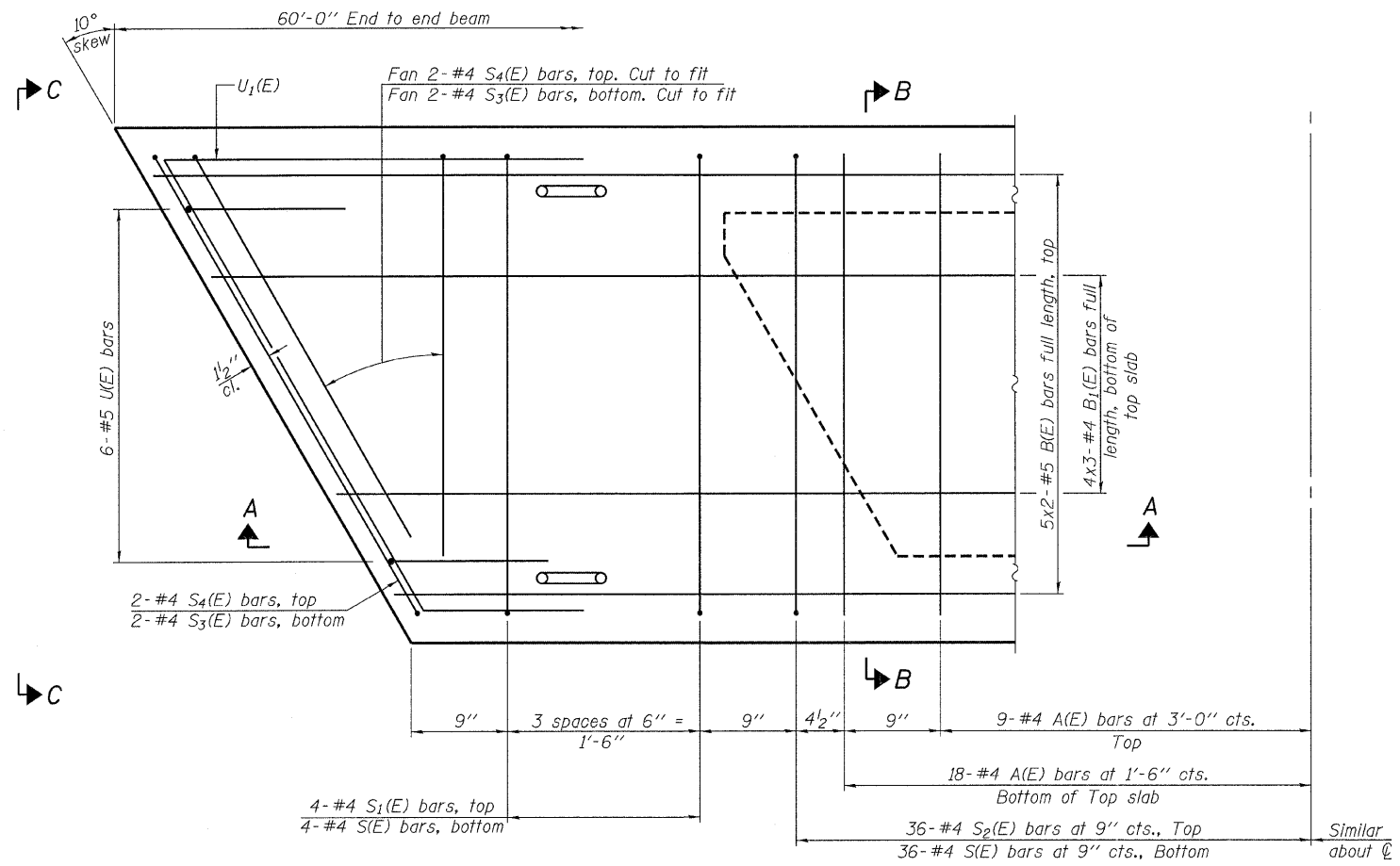

PLAN VIEW

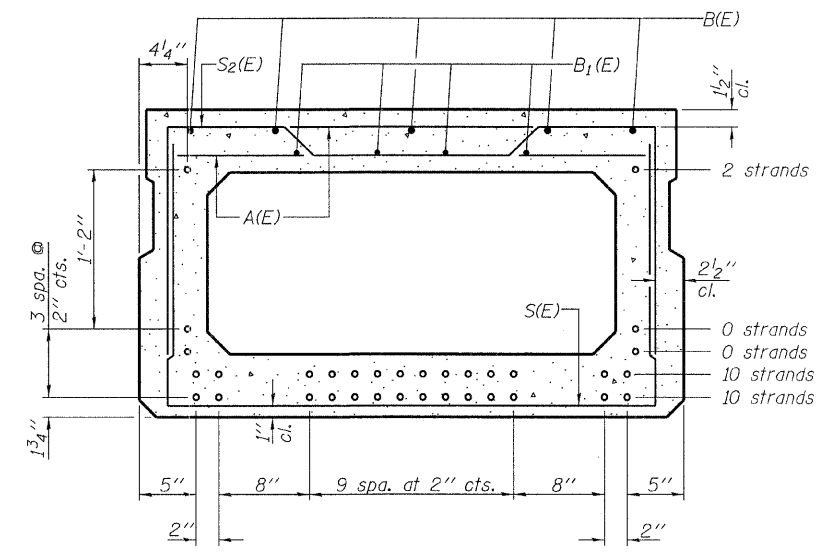

SECTION B-B

(Showing reinforcement and permissible strand locations)
Note: Place the number of strands specified in each row symmetrically about the centerline of beam in the permissible strand locations shown.

BAR LIST
ONE BEAM ONLY
(For information only)

Bar	No.	Size	Length	Shape
A(E)	54	#4	3'-7"	—
B(E)	10	#5	31'-2"	—
B1(E)	12	#4	21'-3"	—
S(E)	80	#4	7'-5"	┌
S1(E)	8	#4	6'-11"	┌
S2(E)	72	#4	7'-2"	┌
S3(E)	8	#4	4'-8"	┌
S4(E)	8	#4	4'-5"	┌
U(E)	12	#5	4'-6"	┌
U1(E)	4	#4	6'-8"	┌

Note: See sheets 3 & 4 of 10 for additional details and Bill of Material.

MINIMUM BAR LAP

#4 bar = 2'-0"
#5 bar = 2'-6"

Notes:
Spacing of S(E) and S2(E) bars may be adjusted up to 4" in the immediate area of the transverse tie diaphragms to miss the block outs for the transverse ties.
Bars indicated thus 5x2-#5 etc. indicates 5 lines of bars with 2 lengths per line.

PD-2748-R 7-1-10

FILE NAME = 110071-shc-bridge.dgn	USER NAME =	DESIGNED - A.S.L.	REVISED -
HAMPTON, LENZINI AND RENWICK, INC. 300 STEVENSON DRIVE, SUITE 201 SPRINGFIELD, ILLINOIS 62761		CHECKED - S.W.M.	REVISED -
ILLINOIS PROFESSIONAL DESIGN FIRM L5 / PE / SE CORP. 184.000959	PLOT SCALE =	DRAWN - D.A.B.	REVISED -
	PLOT DATE = 2/10/2012	CHECKED - S.W.M.	REVISED -

STATE OF ILLINOIS
WHITE COUNTY HIGHWAY DEPARTMENT

27" x 48" PPC DECK BEAM
STRUCTURE NO. 097-3275

SHEET NO. 2 OF 10 SHEETS

T.R.	SECTION	COUNTY	TOTAL SHEETS	SHEET NO.
251	09-08140-00-BR	WHITE	14	6
INDIAN CREEK ROAD DISTRICT		CONTRACT NO. 99474		
ILLINOIS FED. AID PROJECT				

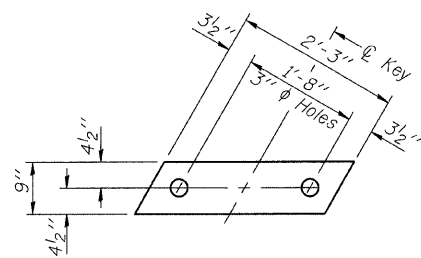

FABRIC BEARING PAD
(Interior - 10 Required)

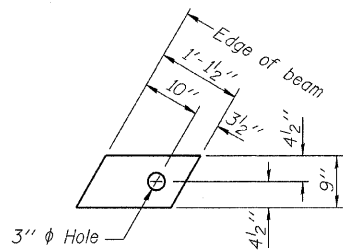

FABRIC BEARING PAD
(Exterior - 4 Required)

FIXED

Notes:
All bearing pads shall be 1" thick.
Omit holes when using expansion bearings.
Expansion bearing pad shall be bonded to the substructure.

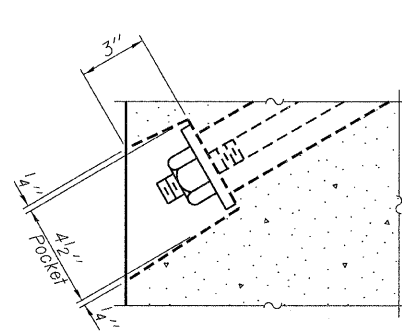

SECTION A-A

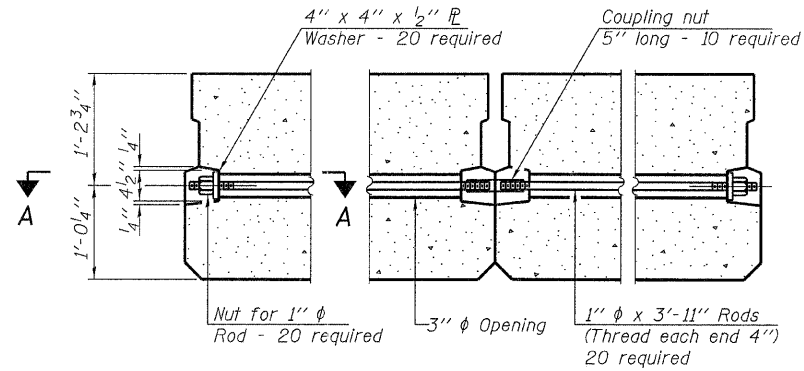

TYPICAL TRANSVERSE TIE ASSEMBLY

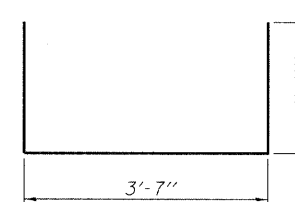

BAR S(E)

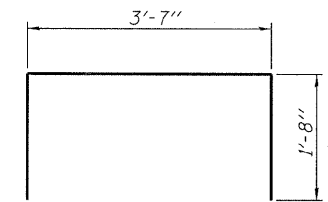

BAR S1(E)

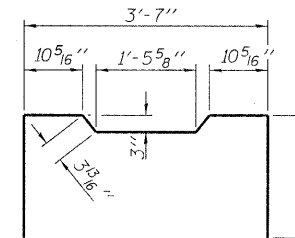

BAR S2(E)

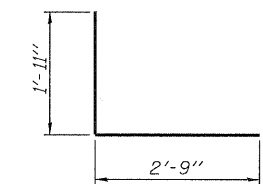

BAR S3(E)

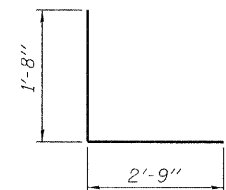

BAR S4(E)

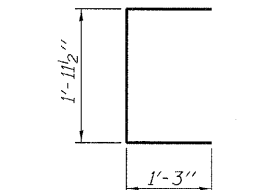

BAR U(E)

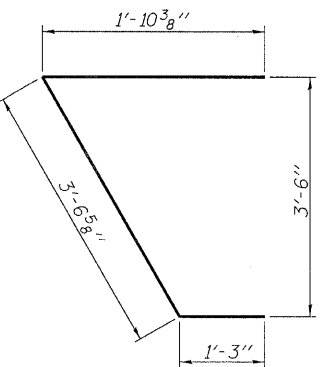

BAR U1(E)

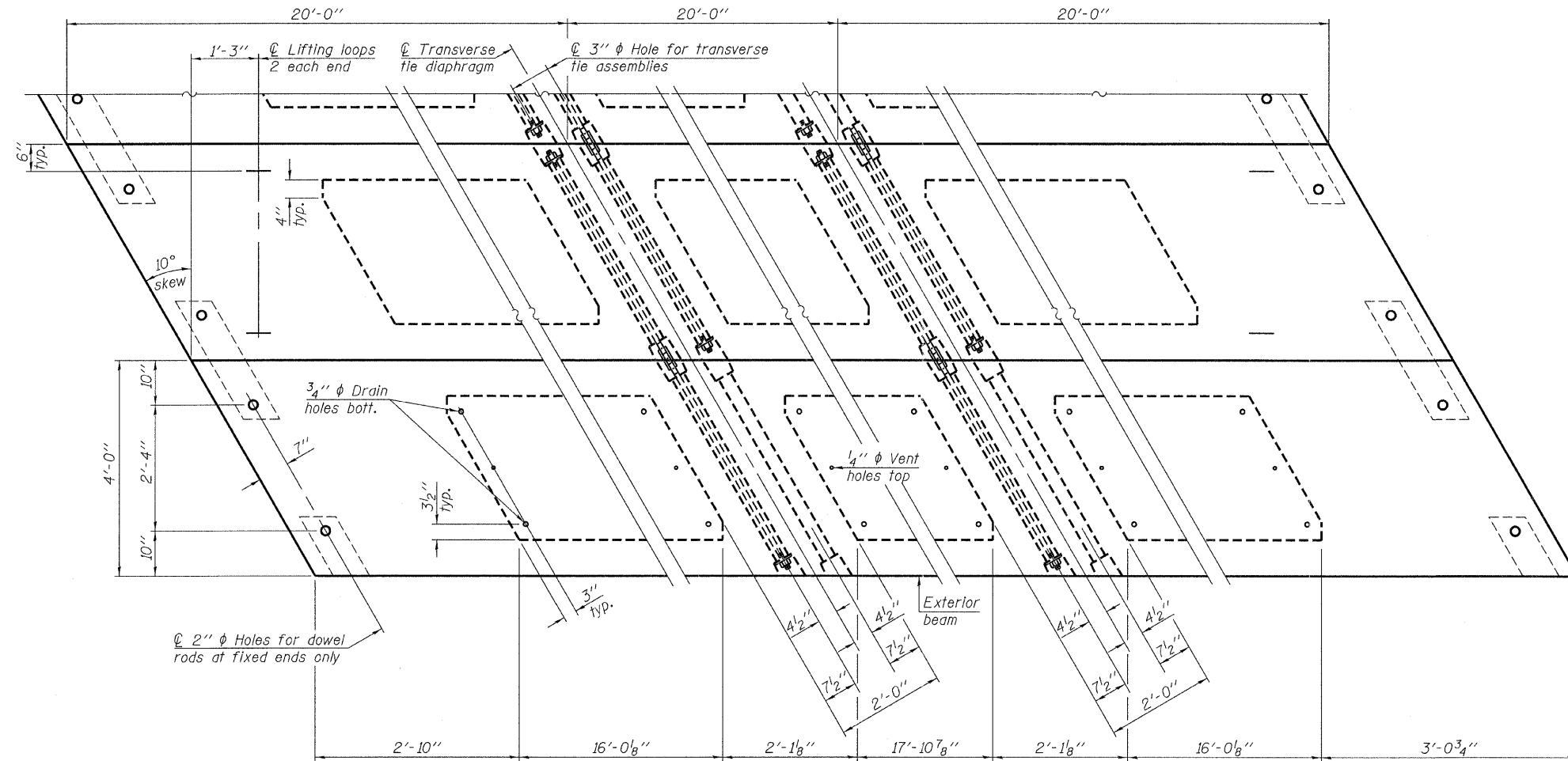

PLAN VIEW

NOTES

Prestressing steel shall be uncoated high strength, low relaxation 7-wire strand, Grade 270. The nominal diameter shall be 1/2" and the nominal cross-sectional area shall be 0.153 sq. in. The 1" rods in the transverse tie assembly shall be tightened to a snug fit and the threads set. Pockets on exterior faces of bridge shall be filled with grout after transverse tie assembly is in place.
Reinforcement bars shall conform to ASTM A 706, Grade 60. (See Special Provisions).
Two 1/8" fabric adjusting shims of the dimensions of the exterior bearing pad shall be provided for each bearing pad location.
A minimum 2 1/2" diameter lifting pin shall be used to engage the lifting loops during handling.
Corrosion Inhibitor, per Article 1020.05(b)(12) and 1021.06 of the Standard Specifications, shall be used in the concrete for precast prestressed concrete deck beams.
Compressive strength of prestressed concrete, f'c, shall be 6000 psi.
Compressive strength of prestressed concrete at release, f'ci, shall be 5000 psi.
All reinforcement shall be epoxy coated.

Note: Connect beams in pairs with the transverse tie configuration shown.

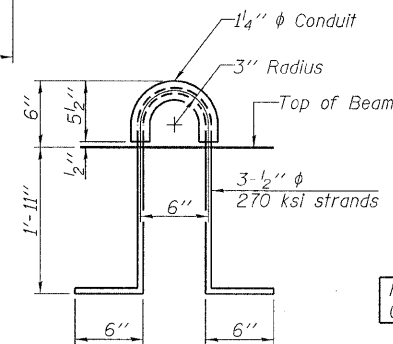

LIFTING LOOP DETAIL

BILL OF MATERIAL

Precast Prestressed Conc. Deck Bms. (27" depth)	Sq. Ft.	1,440
---	---------	-------

PD-2748-RD

7-1-10

FILE NAME = 110071-shr-bridge.dgn	USER NAME =	DESIGNED - A.S.L.	REVISED -
HAMPTON, LENZINI AND RENWICK, INC.		CHECKED - S.W.M.	REVISED -
2045 STEVENSON DRIVE, SUITE 201 SPRINGFIELD, ILLINOIS 62793	PLOT SCALE =	DRAWN - D.A.B.	REVISED -
ILLINOIS PROFESSIONAL DESIGN FIRM LS / PE / SE CORP. 184 000959	PLOT DATE = 2/10/2012	CHECKED - S.W.M.	REVISED -

**STATE OF ILLINOIS
WHITE COUNTY HIGHWAY DEPARTMENT**

**27" x 48" PPC DECK BEAM DETAILS
STRUCTURE NO. 097-3275**

SHEET NO. 3 OF 10 SHEETS

T.R.	SECTION	COUNTY	TOTAL SHEETS	SHEET NO.
251	09-08140-00-BR	WHITE	14	7
INDIAN CREEK ROAD DISTRICT		CONTRACT NO. 99474		
ILLINOIS FED. AID PROJECT				

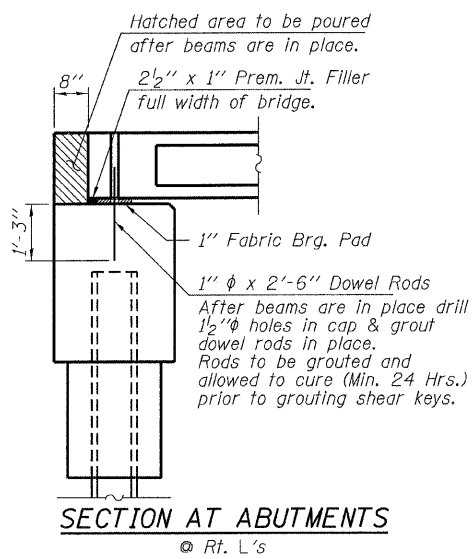
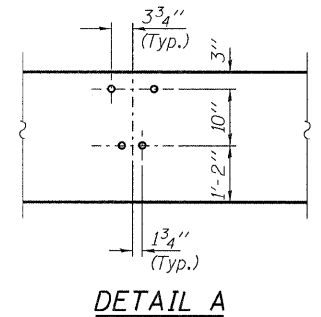
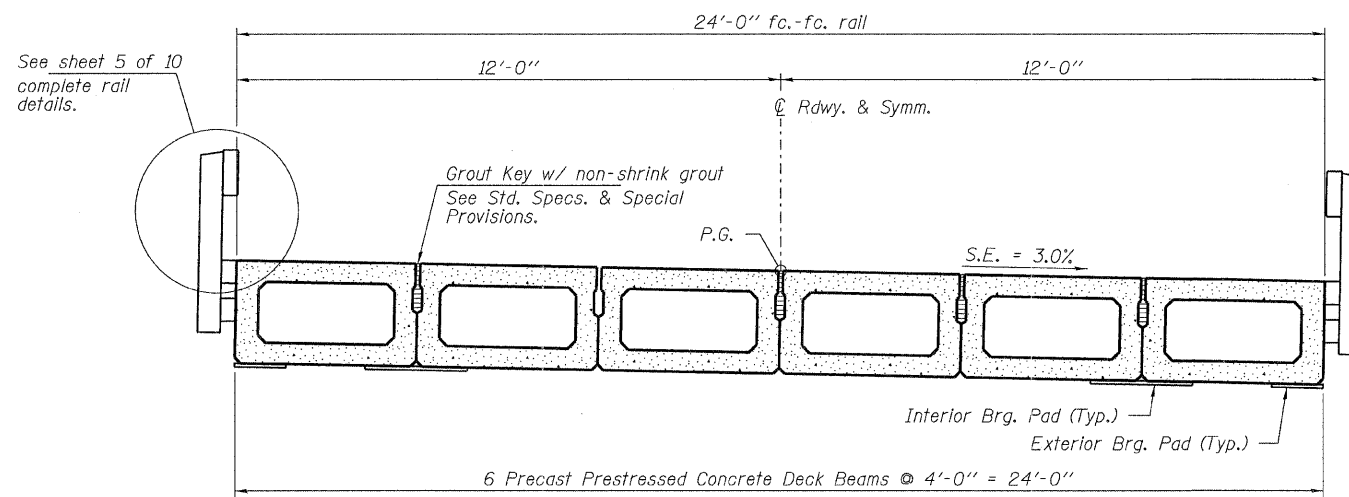
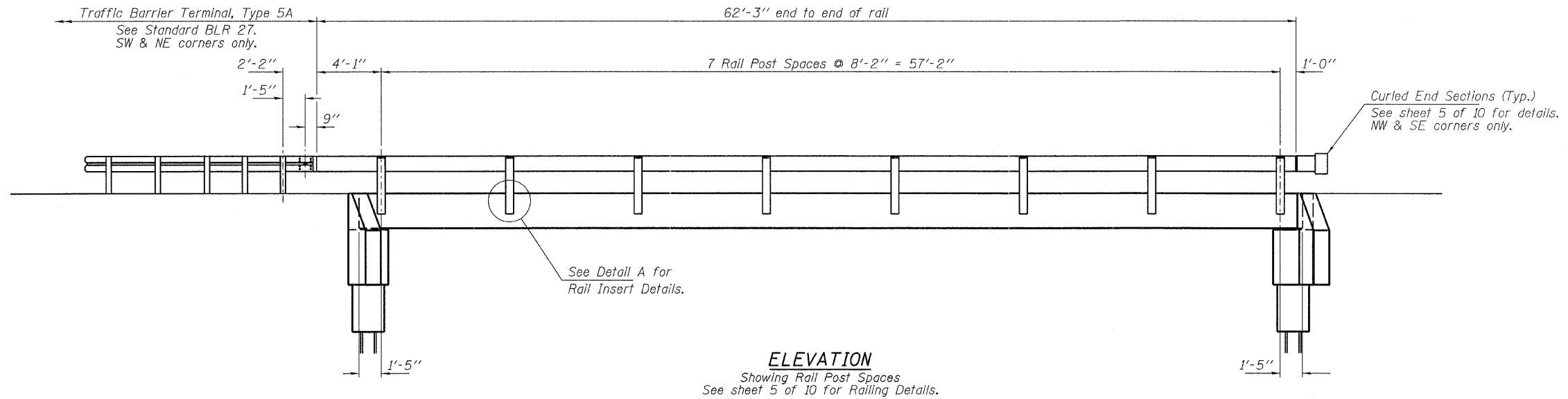

FILE NAME = 11071-sht-bridge.dgn	USER NAME =	DESIGNED - A.S.L.	REVISED -
HAMPTON, LENZINI AND RENWICK, INC.		CHECKED - S.W.M.	REVISED -
2395 STEVENSON DRIVE, SUITE 201 SPRINGFIELD, ILLINOIS 62705	PLOT SCALE =	DRAWN - D.A.B.	REVISED -
ILLINOIS PROFESSIONAL DESIGN FIRM LS / PE / SE CORP. 184-000959	PLOT DATE = 2/10/2012	CHECKED - S.W.M.	REVISED -

STATE OF ILLINOIS
WHITE COUNTY HIGHWAY DEPARTMENT

SUPERSTRUCTURE DETAILS
STRUCTURE NO. 097-3275

SHEET NO. 4 OF 10 SHEETS

T.R.	SECTION	COUNTY	TOTAL SHEETS	SHEET NO.
251	09-08140-00-BR	WHITE	14	8
INDIAN CREEK ROAD DISTRICT		CONTRACT NO. 99474		
ILLINOIS FED. AID PROJECT				

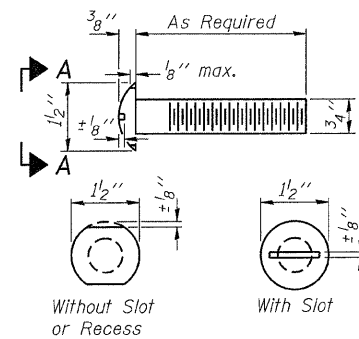

**VIEW A-A
ROUND HEAD BOLT**

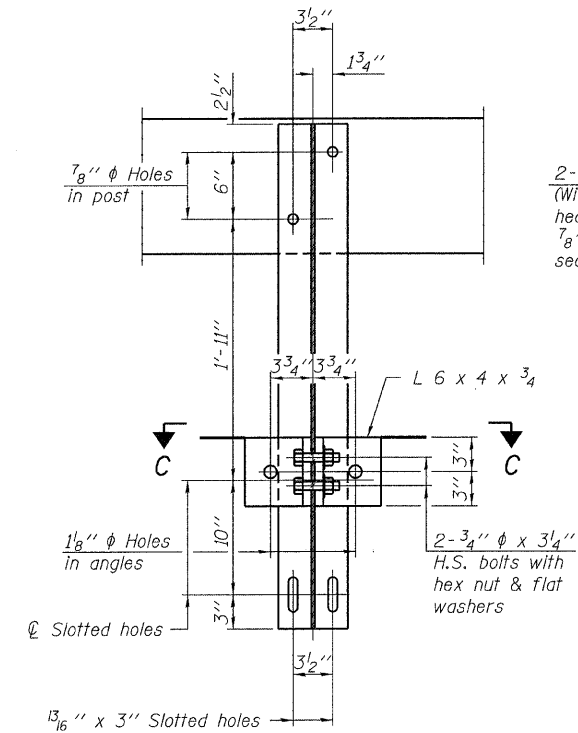
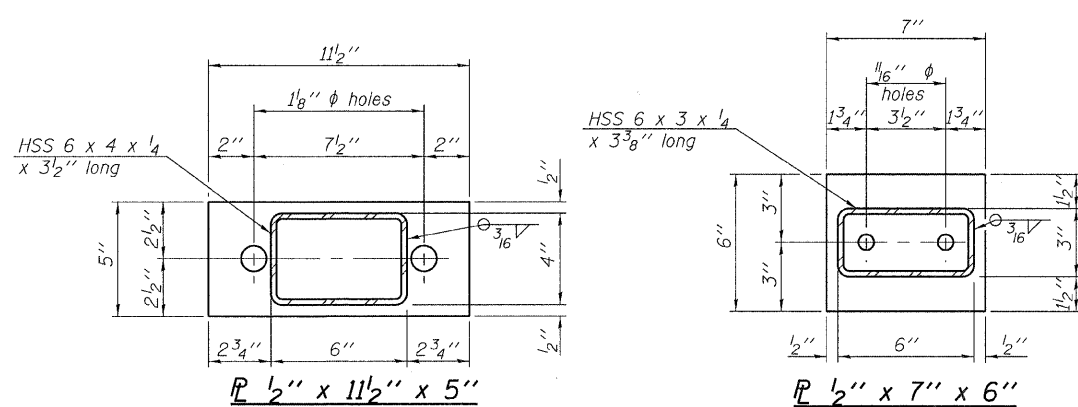

SECTION C-C

** Whenever the lower insert assemblies interfere with strand locations, the #3 bars shall be cut and adjusted in order to allow raising or lowering of the lower inserts. Maximum adjustment not to exceed 2".

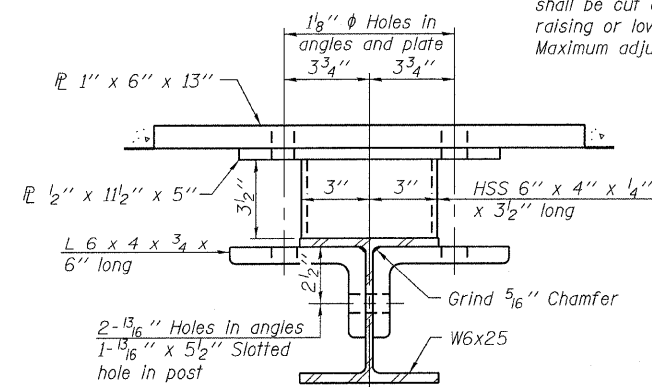

SECTION C-C

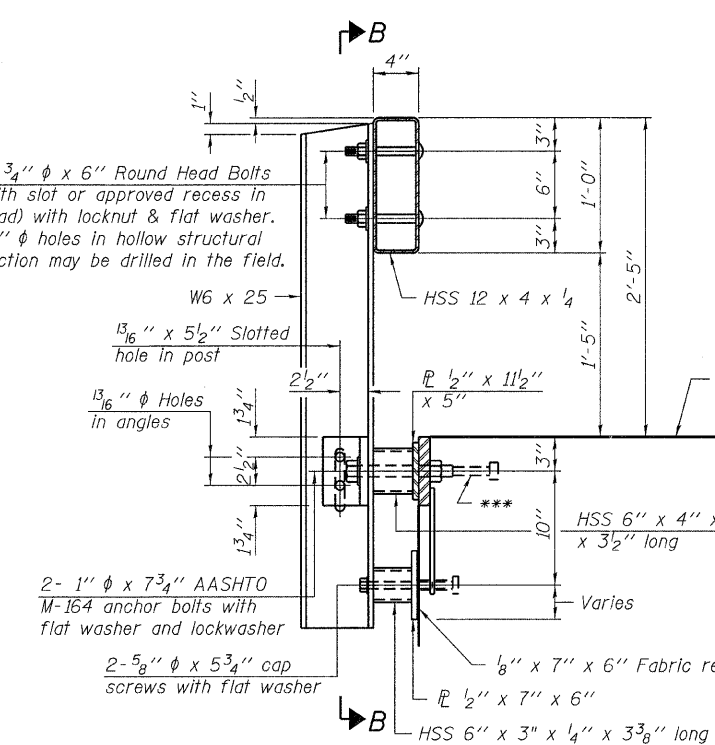

SECTION AT RAILING POST

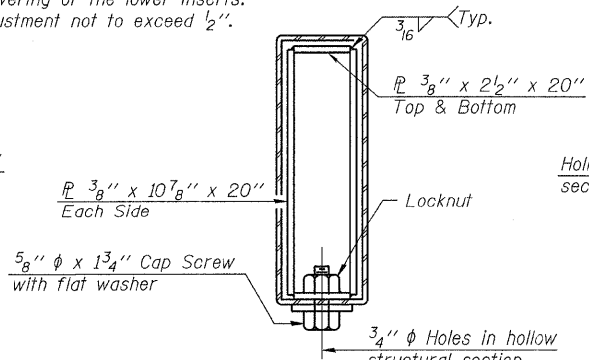

SECTIONS AT RAIL SPLICE

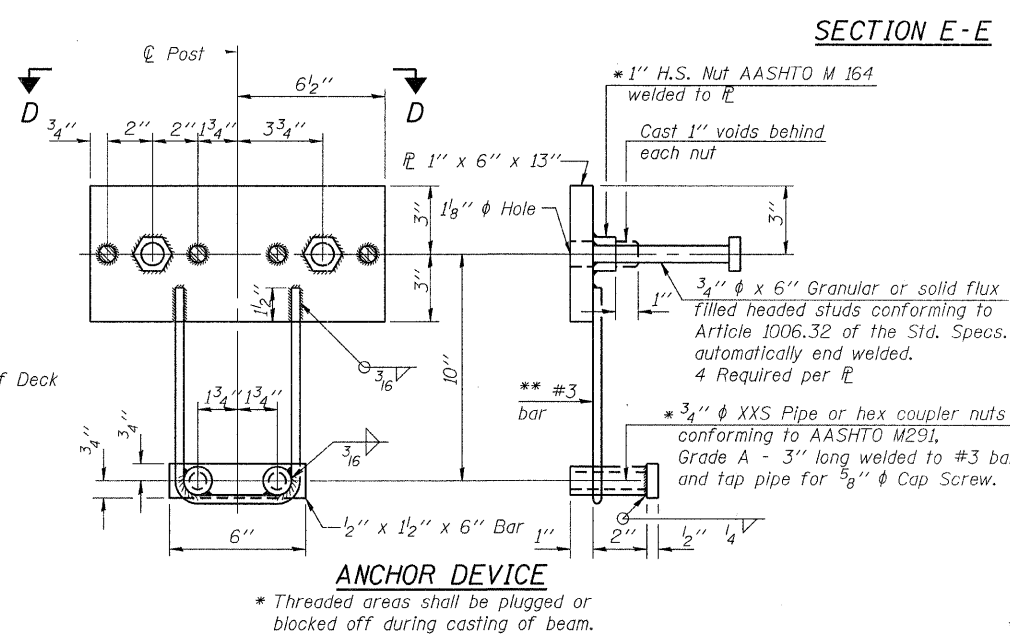

ANCHOR DEVICE

* Threaded areas shall be plugged or blocked off during casting of beam.

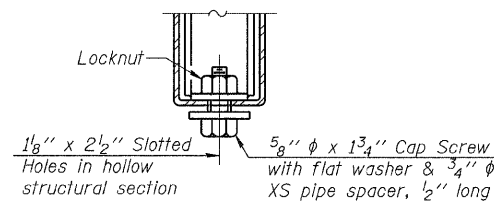

**RAIL SPLICE CONNECTION
AT EXPANSION JT.**

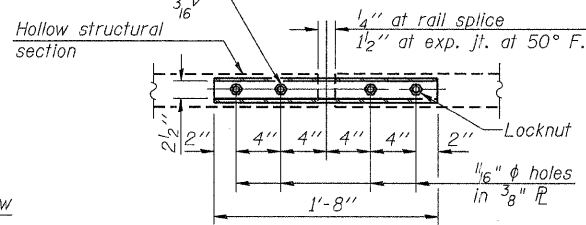

**PLAN-BOTT. SPLICE PL
TYPICAL**

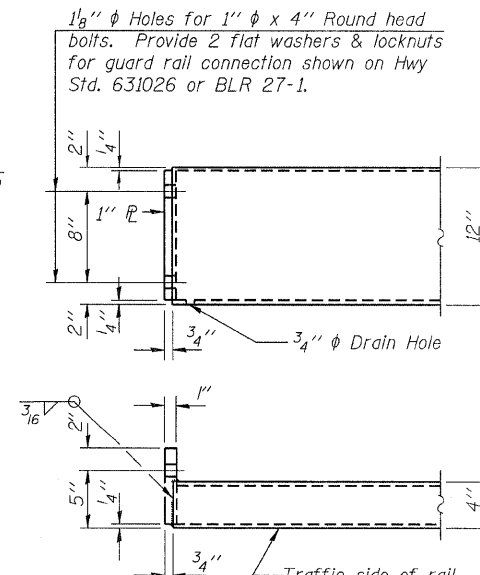

END OF RAIL DETAILS

Note: Cost of curled end sections shall be included with the Steel Railing. (2 Required)

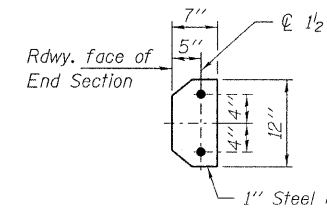

SECTION E-E

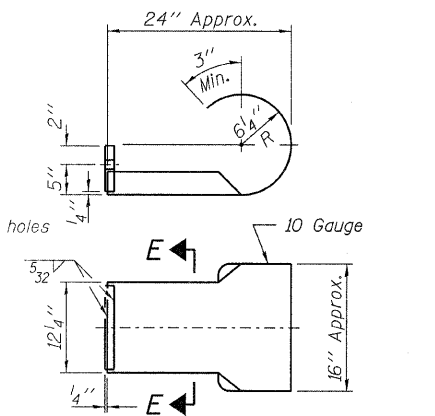

CURLLED END SECTION DETAILS

Notes:
All field drilled holes shall be coated with an approved zinc rich paint before erection.
For multi-span bridges, sufficient 1/4 inch x 6 inch x 1-2 inch galvanized steel shims shall be provided to align rail between adjacent spans. Cost included with Steel Railing, Type S-1.
All steel rail elements shall be galvanized according to Article 509.05 of the Standard Specifications.

*** The studs of the anchor devices shall be placed below the top reinforcement bars and the outermost longitudinal reinforcement bar shall be placed directly above the studs of the rail post anchor device.

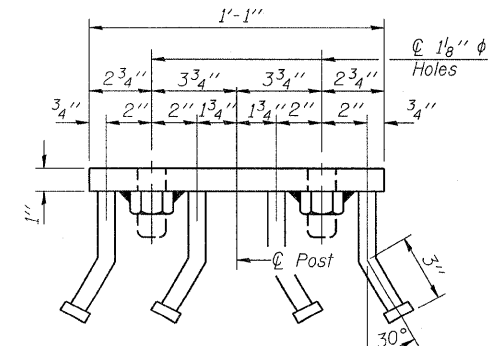

VIEW D-D

BILL OF MATERIAL

Item	Unit	Quantity
Steel Railing, Type S-1	Foot	125

R-23A 7-1-10 (10'-9" Maximum Post Spacing)

FILE NAME = 110871-shr-bridge.dgn	USER NAME =	DESIGNED - A.S.L.	REVISED -
HAMPTON, LENZINI AND RENWICK, INC.		CHECKED - S.W.M.	REVISED -
3085 STEVENSON DRIVE, SUITE 201 SPRINGFIELD, ILLINOIS 62703	PLOT SCALE =	DRAWN - D.A.B.	REVISED -
ILLINOIS PROFESSIONAL DESIGN FIRM 13 / PE / SE CORP. 184-000959	PLOT DATE = 2/10/2012	CHECKED - S.W.M.	REVISED -

**STATE OF ILLINOIS
WHITE COUNTY HIGHWAY DEPARTMENT**

**STEEL RAILING, TYPE S-1
STRUCTURE NO. 097-3275**

SHEET NO. 5 OF 10 SHEETS

T.R.	SECTION	COUNTY	TOTAL SHEETS	SHEET NO.
251	09-08140-00-BR	WHITE	14	9
INDIAN CREEK ROAD DISTRICT		CONTRACT NO. 99474		
ILLINOIS FED. AID PROJECT				

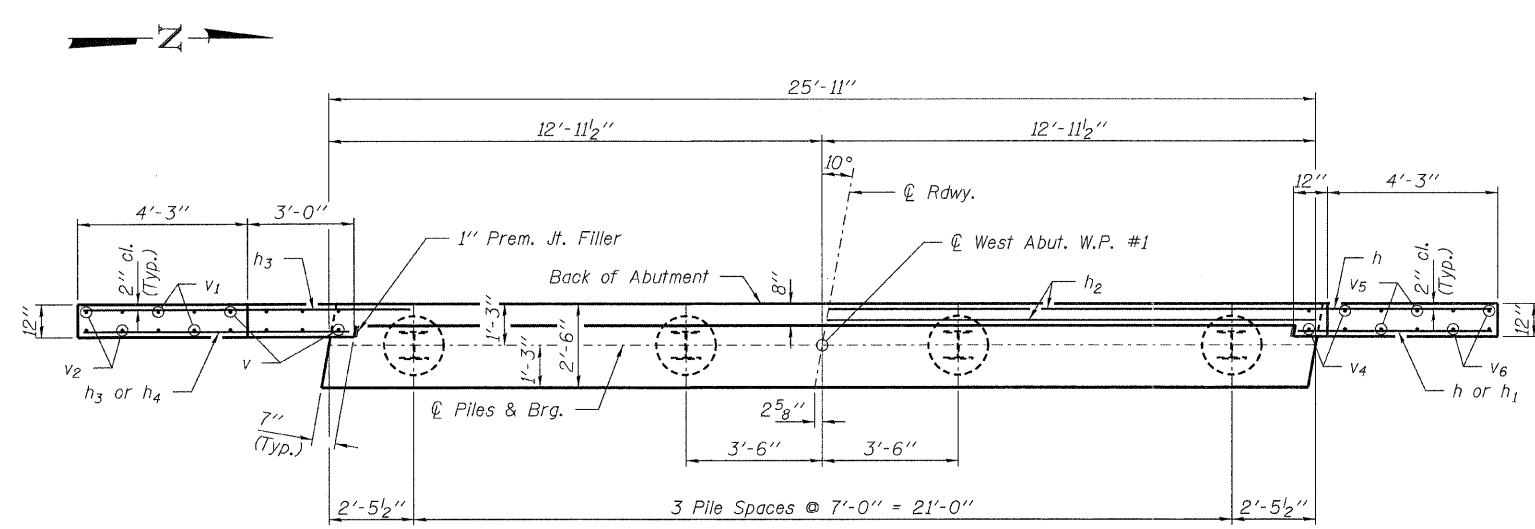

PLAN

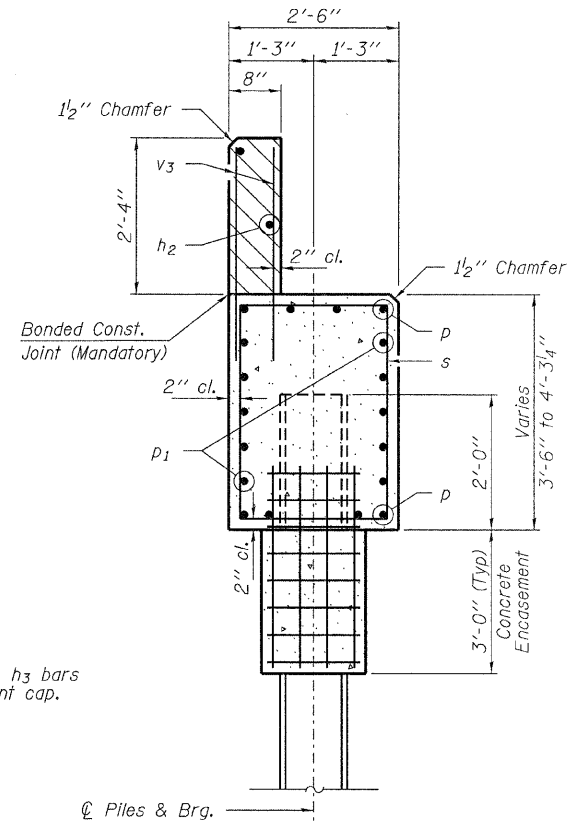

SECTION A-A

Hatched area to be poured after beams are in place.

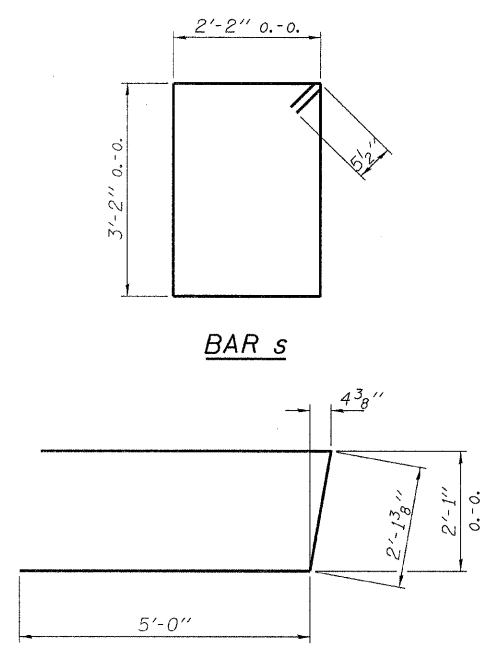

BAR s

BAR u

Note: Extend h & h3 bars into abutment cap.

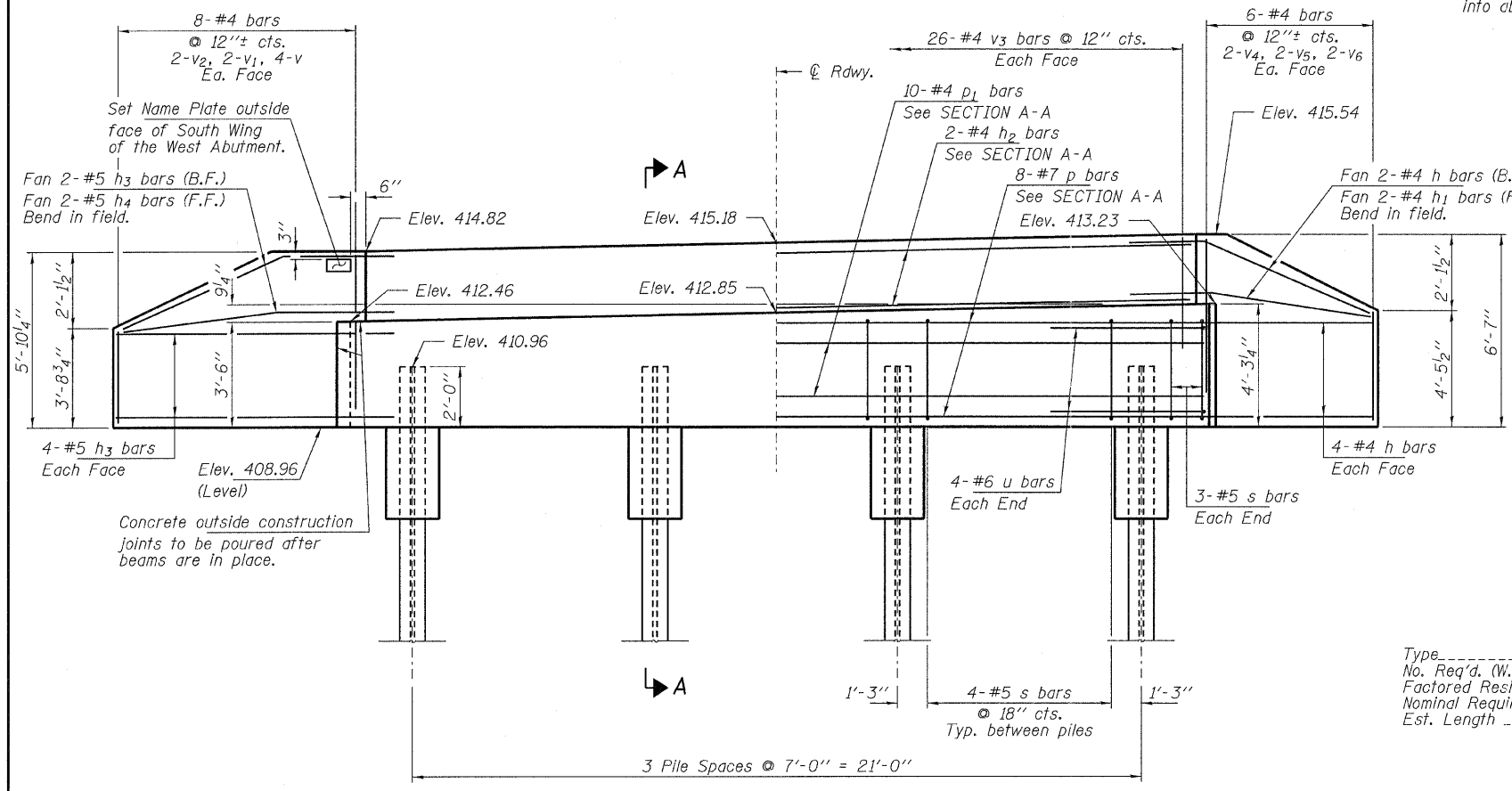

ELEVATION
(Looking West)

PILE DATA

Type ----- Steel HP10x42
 No. Req'd. (W. Abut.) ----- 4
 Factored Resistance Available (Rf) ----- 184 Kips/Pile
 Nominal Required Bearing (Rn) ----- 335 Kips/Pile
 Est. Length ----- 55 Ft/Pile

BILL OF MATERIAL - W. ABUT.

BAR	NO.	SIZE	LENGTH	SHAPE
h	10	#4	6'-6"	—
h1	2	#4	5'-0"	—
h2	2	#4	25'-7"	—
h3	10	#5	8'-6"	—
h4	2	#5	7'-0"	—
p	8	#7	25'-7"	—
p1	10	#4	25'-7"	—
s	18	#5	11'-7"	□
u	8	#6	12'-2"	U
v	8	#4	5'-5"	—
v1	4	#4	4'-5"	—
v2	4	#4	3'-5"	—
v3	52	#4	3'-2"	—
v4	4	#4	6'-2"	—
v5	4	#4	5'-2"	—
v6	4	#4	4'-2"	—
Concrete Structures			Cu. Yd.	13.1
Concrete Encasement			Cu. Yd.	1.4
Reinforcement Bars			Pound	1,340
Steel Piles HP10x42			Foot	220
Name Plates			Each	1

FILE NAME = 11071-sh-t-brj-dge.dgn
 USER NAME =
 DESIGNED - A.S.L.
 CHECKED - S.W.M.
 DRAWN - D.A.B.
 CHECKED - S.W.M.
 PLOT SCALE =
 PLOT DATE = 2/10/2012

DESIGNED - A.S.L.
 CHECKED - S.W.M.
 DRAWN - D.A.B.
 CHECKED - S.W.M.
 REVISIONS:
 REVISIONS:
 REVISIONS:
 REVISIONS:

STATE OF ILLINOIS
WHITE COUNTY HIGHWAY DEPARTMENT

WEST ABUTMENT
STRUCTURE NO. 097-3275
 SHEET NO. 7 OF 10 SHEETS

T.R.	SECTION	COUNTY	TOTAL SHEETS	SHEET NO.
251	09-08140-00-BR	WHITE	14	10
INDIAN CREEK ROAD DISTRICT			CONTRACT NO. 99474	
ILLINOIS FED. AID PROJECT				

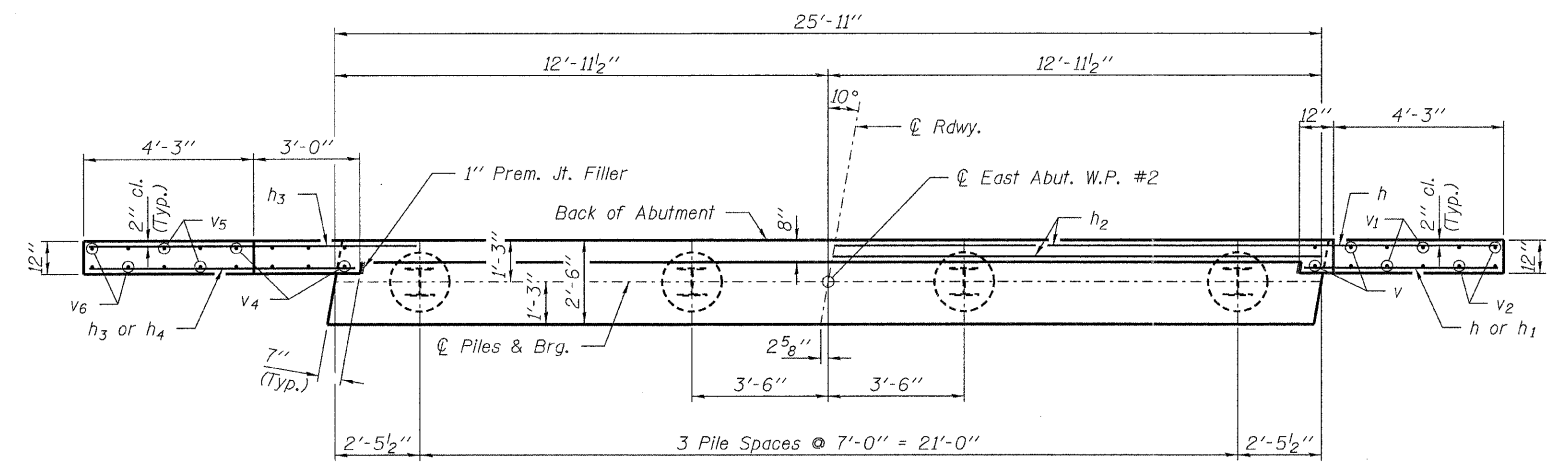
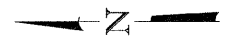

PLAN

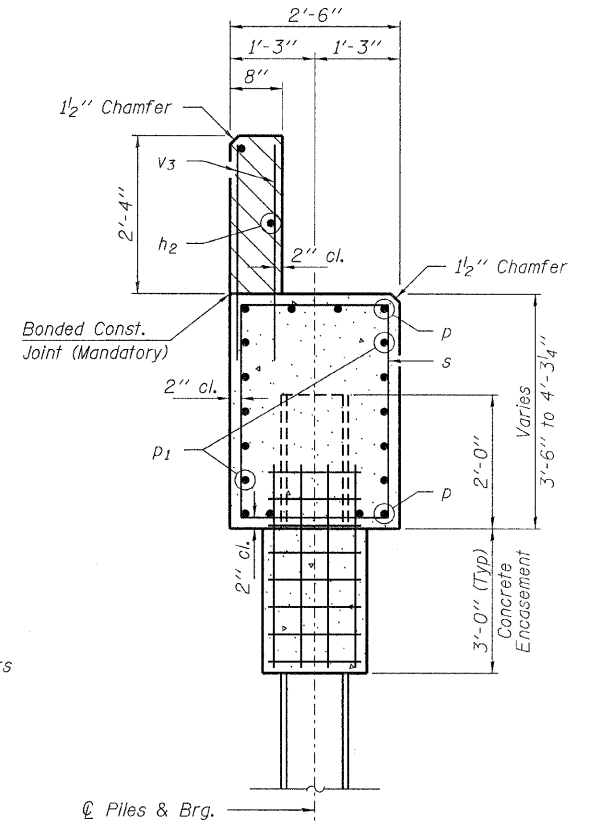

SECTION A-A

Hatched area to be poured after beams are in place.

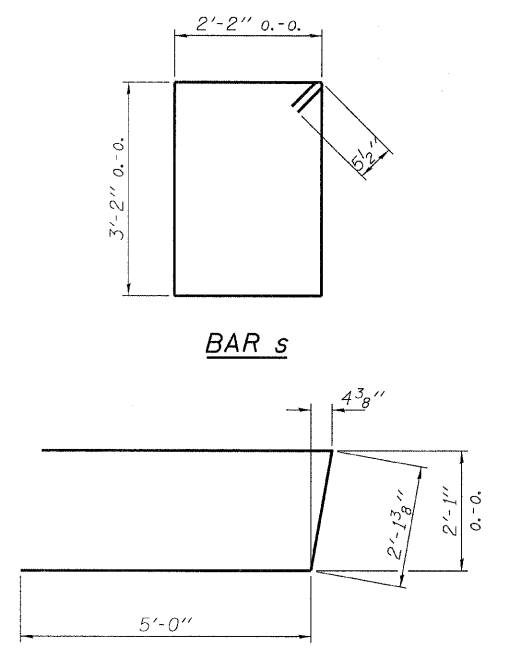

BAR s

BAR u

Note: Extend h & h3 bars into abutment cap.

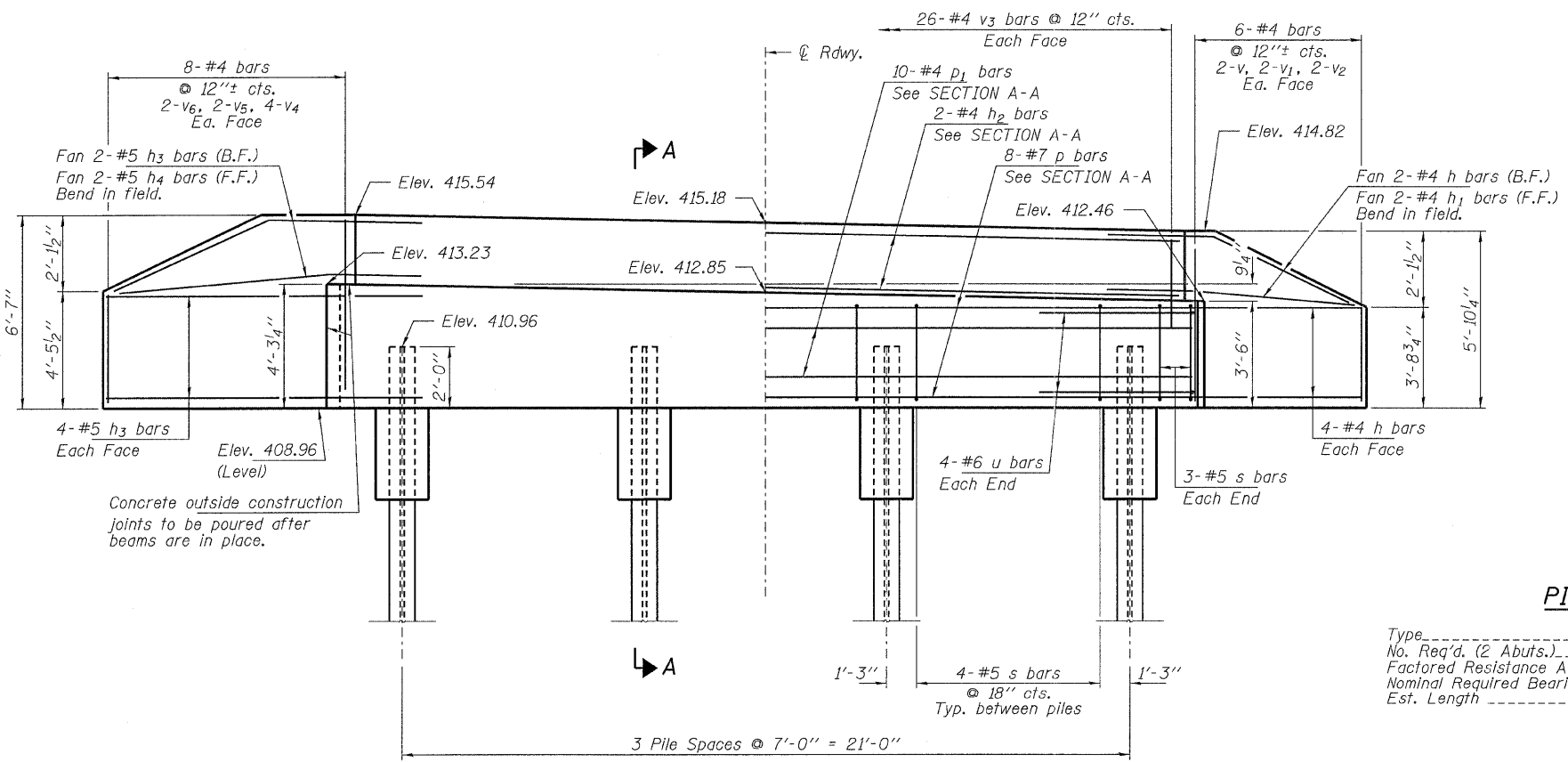

ELEVATION
(Looking East)

PILE DATA

Type ----- Steel HP10x42
 No. Req'd. (2 Abuts.) ----- 4
 Factored Resistance Available (Rf) ----- 184 Kips/Pile
 Nominal Required Bearing (Rn) ----- 335 Kips/Pile
 Est. Length ----- 55 Ft./Pile

BILL OF MATERIAL - E. ABUT.

BAR	NO.	SIZE	LENGTH	SHAPE
h	10	#4	6'-6"	—
h1	2	#4	5'-0"	—
h2	2	#4	25'-7"	—
h3	10	#5	8'-6"	—
h4	2	#5	7'-0"	—
p	8	#7	25'-7"	—
p1	10	#4	25'-7"	—
s	18	#5	11'-7"	□
u	4	#6	12'-2"	U
v	4	#4	5'-5"	—
v1	4	#4	4'-5"	—
v2	4	#4	3'-5"	—
v3	52	#4	3'-2"	—
v4	8	#4	6'-2"	—
v5	4	#4	5'-2"	—
v6	4	#4	4'-2"	—
Concrete Structures			Cu. Yd.	13.1
Concrete Encasement			Cu. Yd.	1.4
Reinforcement Bars			Pound	1,340
Steel Piles HP10x42			Foot	220

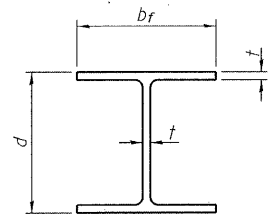

STEEL PILE TABLE

Designation	Depth <i>d</i>	Flange width <i>br</i>	Web and Flange thickness <i>t</i>	Encasement diameter <i>A</i>
HP 14x117	14 1/4"	14 7/8"	13/16"	30"
x102	14"	14 3/4"	1/16"	30"
x89	13 7/8"	14 3/4"	5/8"	30"
x73	13 5/8"	14 5/8"	1/2"	30"
HP 12x84	12 1/4"	12 1/4"	1/16"	24"
x74	12 1/8"	12 1/4"	5/8"	24"
x63	12"	12 1/8"	1/2"	24"
x53	11 3/4"	12"	7/16"	24"
HP 10x57	10"	10 1/4"	9/16"	24"
x42	9 3/4"	10 1/8"	7/16"	24"
HP 8x36	8"	8 1/8"	7/16"	18"

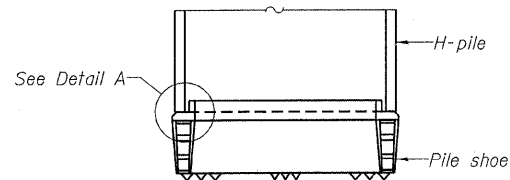

ELEVATION

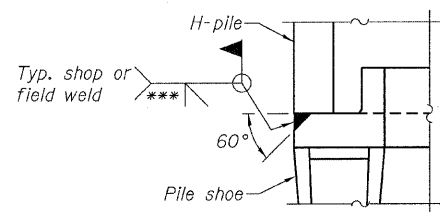

DETAIL A

H-PILE SHOE ATTACHMENT

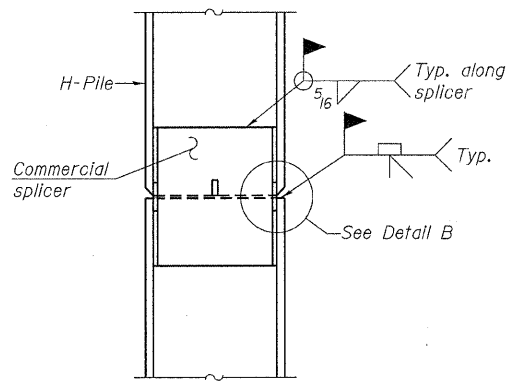

ELEVATION

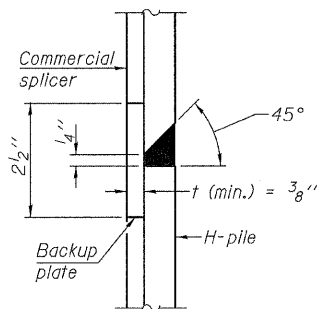

DETAIL "B"

WELDED COMMERCIAL SPLICE

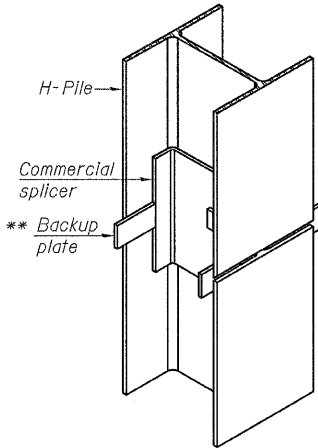

ISOMETRIC VIEW

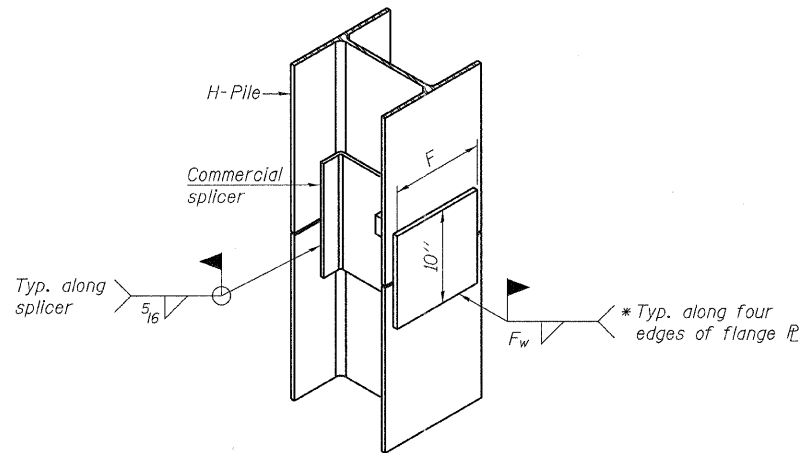

ISOMETRIC VIEW

WELDED COMMERCIAL SPLICE ALTERNATE

- * Interrupt welds 1/4" from end of web and/or each flange.
- ** Remove portions of backup plates that extend outside the flanges.
- *** Weld size per pile shoe manufacturer (5/16" min.).

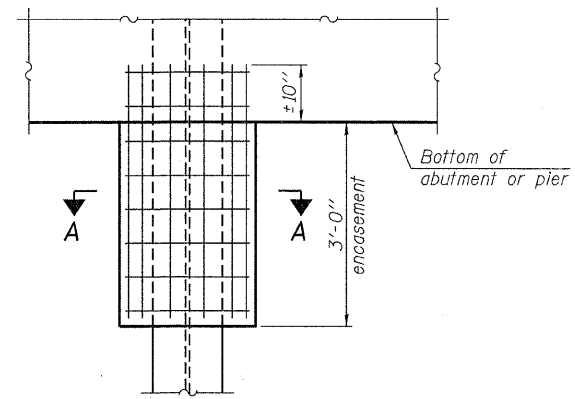

ELEVATION

PILE ENCASEMENT

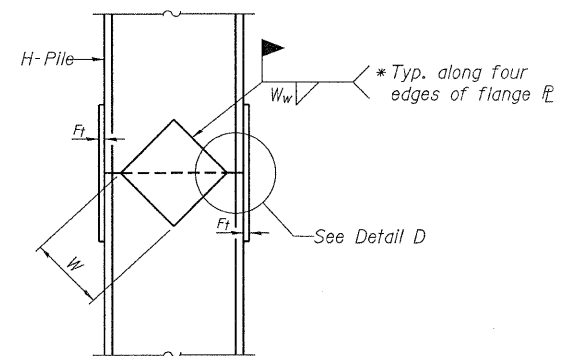

ELEVATION

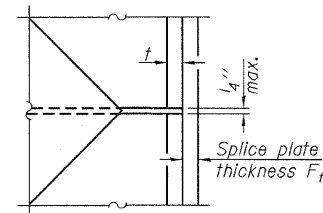

DETAIL D

WELDED PLATE FIELD SPLICE

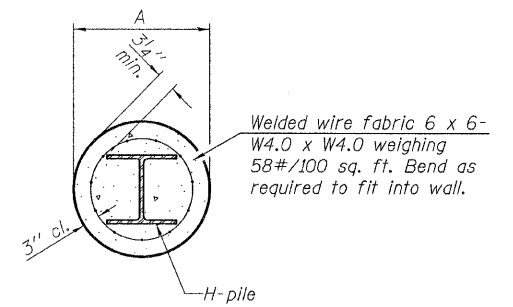

SECTION A-A

Note:
Forms for encasement may be omitted when soil conditions permit.

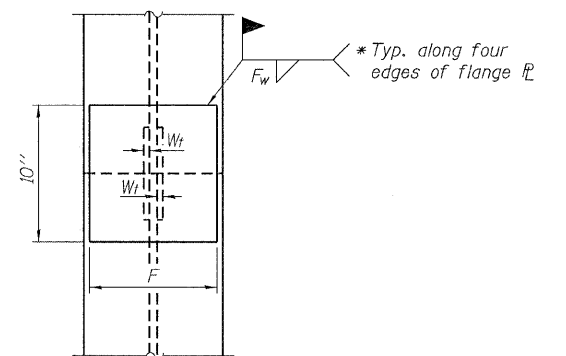

END VIEW

Designation	F	F _t	F _w	W	W _t	W _w
HP 14x117	12 1/2"	1"	7/8"	7 3/4"	5 1/8"	1/2"
x102	12 1/2"	7/8"	3/4"	7 3/4"	5 1/8"	1/2"
x89	12 1/2"	3/4"	1/16"	7 3/4"	5 1/8"	1/2"
x73	12 1/2"	5/8"	9/16"	7 3/4"	5 1/8"	1/2"
HP 12x84	10"	7/8"	1/16"	6 1/2"	5 1/8"	1/2"
x74	10"	7/8"	1/16"	6 1/2"	5 1/8"	1/2"
x63	10"	5/8"	1/2"	6 1/2"	1/2"	3/8"
x53	10"	5/8"	1/2"	6 1/2"	1/2"	3/8"
HP 10x57	8"	3/4"	9/16"	5 1/4"	1/2"	3/8"
x42	8"	5/8"	9/16"	5 1/4"	1/2"	3/8"
HP 8x36	7"	5/8"	7/16"	4 1/4"	1/2"	3/8"

Note:
The steel H-piles shall be according to AASHTO M270 Grade 50.

F-HP

7-1-10

FILE NAME = 11071-sht-bridge.dgn	USER NAME =	DESIGNED - A.S.L.	REVISED -	STATE OF ILLINOIS WHITE COUNTY HIGHWAY DEPARTMENT	HP PILE DETAILS STRUCTURE NO. 097-3275	T.R.	SECTION	COUNTY	TOTAL SHEETS	SHEET NO.	
HAMPTON, LENZINI AND RENWICK, INC. 300 STEVENSON DRIVE, SUITE 201 SPRINGFIELD, ILLINOIS 62761	PLOT SCALE =	CHECKED - S.W.M.	REVISED -			251	09-08140-00-BR	WHITE	14	12	
ILLINOIS PROFESSIONAL DESIGN FIRM L5 / PE / SE CORP. 184.000989	PLOT DATE = 2/10/2012	DRAWN - D.A.B.	REVISED -			INDIAN CREEK ROAD DISTRICT		CONTRACT NO. 99474		ILLINOIS FED. AID PROJECT	
		CHECKED - S.W.M.	REVISED -			SHEET NO. 8 OF 10 SHEETS					

HOLCOMB FOUNDATION ENGINEERING INC.									
P.O. Box 88		618-529-5262		Page 1 of 2		Carbondale, IL 62903		618-457-8991 fax	
Bridge Foundation Boring Log									
Project: H-11087		Bridge: Over Bear Creek		Date: 6/9/11		Section: 09-08140-00-BR		Station: _____	
Structure: _____		Bored by: B. Schwartz		Checked By: J. Holcomb		County: White		_____	
Boring No.: 2		Station: _____		Offset: _____		Surface Water Elev. _____		Ground Water Elev. _____	
Elevation		N		Cu tsf		w %		Elevation	
N		Cu tsf		w %		N		Cu tsf	
During Drilling		Upon Completion		During Drilling		Upon Completion		During Drilling	
Upon Completion		During Drilling		Upon Completion		During Drilling		Upon Completion	
Ground Surface		415.0		0					
Gray Mottled Brown Silty CLAY to Clayey SILT (A-6-4)									
		391.0							
11		2.25		20		Brown Clayey SAND (A-2-4)		6	
		388.5							
-5		3		1.08		27		2	
Brown Fine to Medium SAND (A-2-4) w/gravel									
		386.0							
-10		3		1.65		25		11	
Brown Sandy CLAY (A-6)									
		381.0							
-15		11		3.15		18			
Gray Silty CLAY (A-6) w/sand and pebbles									
		401.0							
-15		11		1.55		18		13	
Gray Mottled Brown Silty CLAY to Clayey SILT (A-6-4) w/sand									
		396.0							
-20		11		2.05		18		28	
Gray Mottled Brown Sandy CLAY (A-6)									
		393.5							
-20		3		0.55		21		37	
Gray Mottled Brown Silty CLAY (A-6) w/sand									
		371.0							
Gray Clayey SAND w/gravel (A-2-4)									

N = Standard Penetration Test Blows per foot to drive 2" O.D. Split Spoon Sampler 12" with a 140 lbs. hammer falling 30"

Qu = Unconfined Compressive Strength in tons/sq.ft. w = Water Content - percentage of oven dry weight - %

B = Bulge Failure S = Shear Failure E = Estimated Value P = Penetrometer

HOLCOMB FOUNDATION ENGINEERING INC.									
P.O. Box 88		618-529-5262		Page 2 of 2		Carbondale, IL 62903		618-457-8991 fax	
Bridge Foundation Boring Log									
Project: H-11087		Bridge: Over Bear Creek		Date: 6/9/11		Section: 09-08140-00-BR		Station: _____	
Structure: _____		Bored by: B. Schwartz		Checked By: J. Holcomb		County: White		_____	
Boring No.: 2		Station: _____		Offset: _____		Surface Water Elev. _____		Ground Water Elev. _____	
Elevation		N		Cu tsf		w %		Elevation	
N		Cu tsf		w %		N		Cu tsf	
During Drilling		Upon Completion		During Drilling		Upon Completion		During Drilling	
Upon Completion		During Drilling		Upon Completion		During Drilling		Upon Completion	
gray clayey sand (continued)									
		45		21		16			
		366.0							
-50		23		14		Gray Fine to Medium SAND (A-2-4) w/ gravel		23	
		361.0							
-55		26		15		14		26	
Gray Weathered Shale									
		358.5							
-60		100		/3"		11		100	
Gray Shale									
		353.5							
-65		100		/3"		9		100	
End Of Boring @ -61.5'									

N = Standard Penetration Test Blows per foot to drive 2" O.D. Split Spoon Sampler 12" with a 140 lbs. hammer falling 30"

Qu = Unconfined Compressive Strength in tons/sq.ft. w = Water Content - percentage of oven dry weight - %

B = Bulge Failure S = Shear Failure E = Estimated Value P = Penetrometer

BORING 2

FILE NAME = 110871-ht-bridge.dgn	USER NAME =	DESIGNED - A.S.L.	REVISED -	STATE OF ILLINOIS WHITE COUNTY HIGHWAY DEPARTMENT	BORING STRUCTURE NO. 097-3275	T.R.	SECTION	COUNTY	TOTAL SHEETS	SHEET NO.	
HAMPTON, LENZINI AND RENWICK, INC. 300 STEVENSON DRIVE, SUITE 201 SPRINGFIELD, ILLINOIS 62703	PLOT SCALE =	CHECKED - S.W.M.	REVISED -			251	09-08140-00-BR	WHITE	14	14	
ILLINOIS PROFESSIONAL DESIGN FIRM L3 / PE / SE CORP. 164300899	PLOT DATE = 2/10/2012	DRAWN - D.A.B.	REVISED -			INDIAN CREEK ROAD DISTRICT CONTRACT NO. 99474					
		CHECKED - S.W.M.	REVISED -			ILLINOIS FED. AID PROJECT					