

F.A.I. RTE.	SECTION	COUNTY	TOTAL SHEETS	SHEET NO.
90	*	COOK	81	7
STA.	TO STA.			
FED. ROAD DIST. NO. 1	ILLINOIS	FED. AID PROJECT		
• (1012, 1214, 1415, & 1517) RS-3				

62746

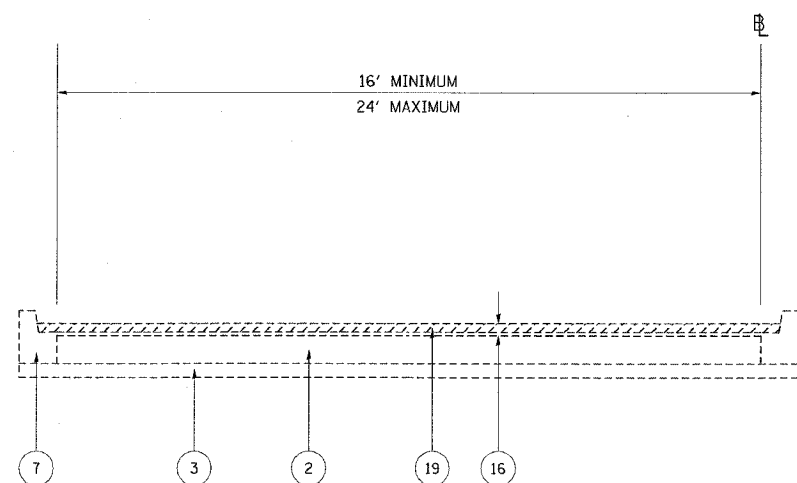

**KENNEDY EXPRESSWAY
EXISTING TYPICAL SECTION
RAMPS**

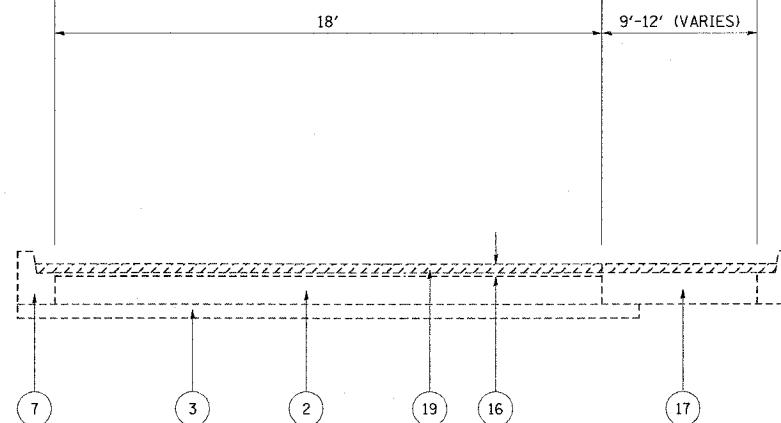

**KENNEDY EXPRESSWAY
EXISTING TYPICAL SECTION
CUMBERLAND ENTRANCE RAMP #4**

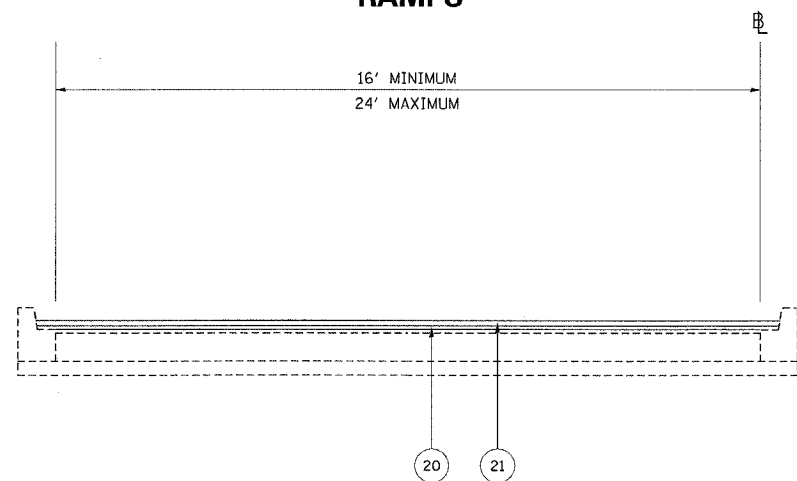

**KENNEDY EXPRESSWAY
PROPOSED TYPICAL SECTION
RAMPS**

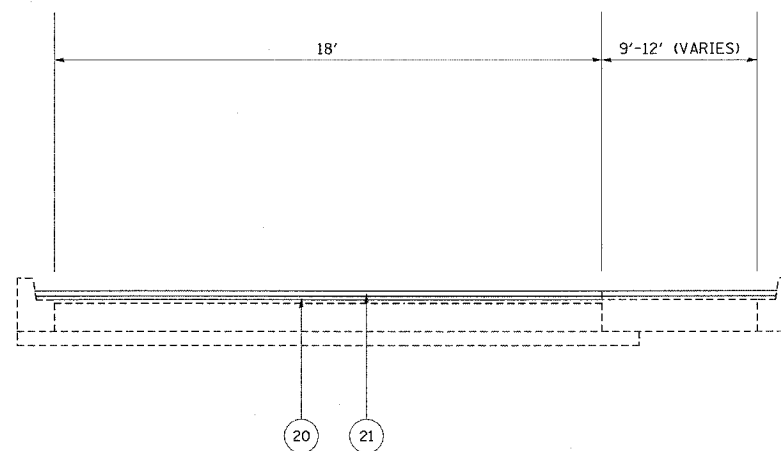

**KENNEDY EXPRESSWAY
PROPOSED TYPICAL SECTION
CUMBERLAND ENTRANCE RAMP #4**

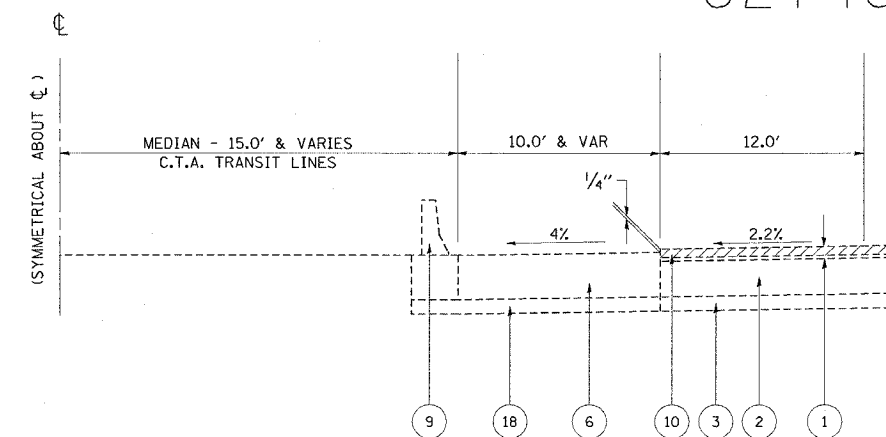

**KENNEDY EXPRESSWAY
STA. 3610+38.00 TO STA. 3646+77.10
EXISTING TYPICAL SECTION**

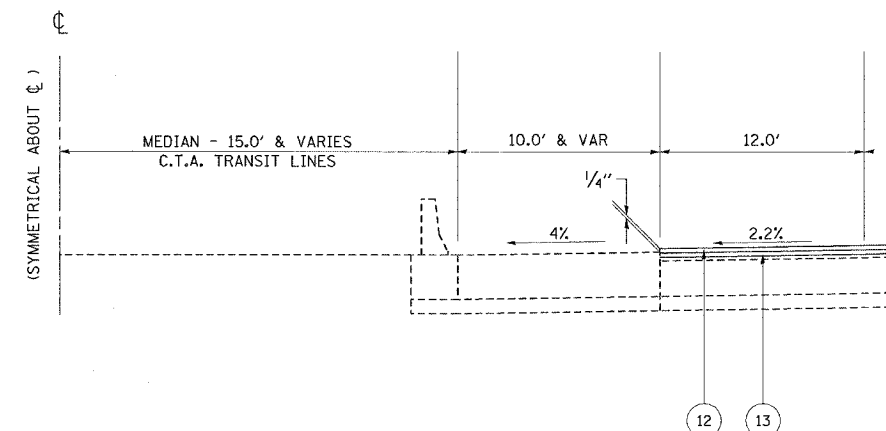

**KENNEDY EXPRESSWAY
STA. 3610+38.00 TO STA. 3646+77.10
PROPOSED TYPICAL SECTION**

2006

LEGEND

- | | | | |
|----|---|----|--|
| 1 | EXISTING BITUMINOUS CONCRETE COURSE, ± 4¾" | 13 | PROP. POLY. BIT. CONC. BINDER COURSE, SMA, SUPERPAVE, N80, 1¾" |
| 2 | EXISTING PORTLAND CEMENT CONCRETE PAVEMENT, 10" (STD. REINFORCED) | 14 | PROPOSED BITUMINOUS CONCRETE SURFACE COURSE, SUPERPAVE, MIX'D", N70, 2" |
| 3 | EXISTING AGGREGATE SUB-BASE, 6" | 16 | EXISTING BITUMINOUS CONCRETE COURSE, ± 2½" |
| 6 | EXISTING P.C.C. SHOULDER, 13" | 17 | EXISTING BITUMINOUS SHOULDER, 10" |
| 7 | EXISTING COMBINATION CONCRETE CURB AND GUTTER, TYPE VARIES (SEE NOTE 2) | 18 | EXISTING SUB-BASE GRANULAR MATERIAL, TYPE B, 6" |
| 9 | EXISTING BARRIER WALL | 19 | PROPOSED BITUMINOUS SURFACE REMOVAL, 2½" |
| 10 | PROPOSED BITUMINOUS SURFACE REMOVAL, 4" | 20 | PROPOSED POLYMERIZED LEVELING BINDER (MACHINE METHOD), SUPERPAVE, IL-4.75, N50, ¾" |
| 12 | PROP. POLY. BIT. CONC. SURFACE COURSE, SMA, SUPERPAVE, N80, 1¾" | 21 | POLY. BIT. CONC. SURFACE COURSE, SUPERPAVE, MIX'F", N90, 1¾" |

NOTES

- MATCH EXISTING ELEVATIONS AT EDGE OF SHOULDER.
- SOME LOCATIONS DO NOT HAVE CURB AND GUTTER. ALSO SHOULDER WIDTH VARIES FROM 10.0' MAXIMUM TO 4.0' MINIMUM.
- MATCH EXISTING ELEVATIONS AT EDGE OF PAVEMENT.

REVISIONS	
NAME	DATE

ILLINOIS DEPARTMENT OF TRANSPORTATION

**KENNEDY EXPRESSWAY
TYPICAL SECTIONS**

SCALE: VERT. NONE
HORIZ. DATE 2/3/2006

DRAWN BY EWK
CHECKED BY