

F.A.U. RTE.	SECTION	COUNTY	TOTAL SHEETS	SHEET NO.
8239	RS,R	MONTGOMERY	302	144
STA.		TO STA.		
FED. ROAD DIST. NO.	ILLINOIS	FED. AID PROJECT		

**CONTRACT NO. 72526**

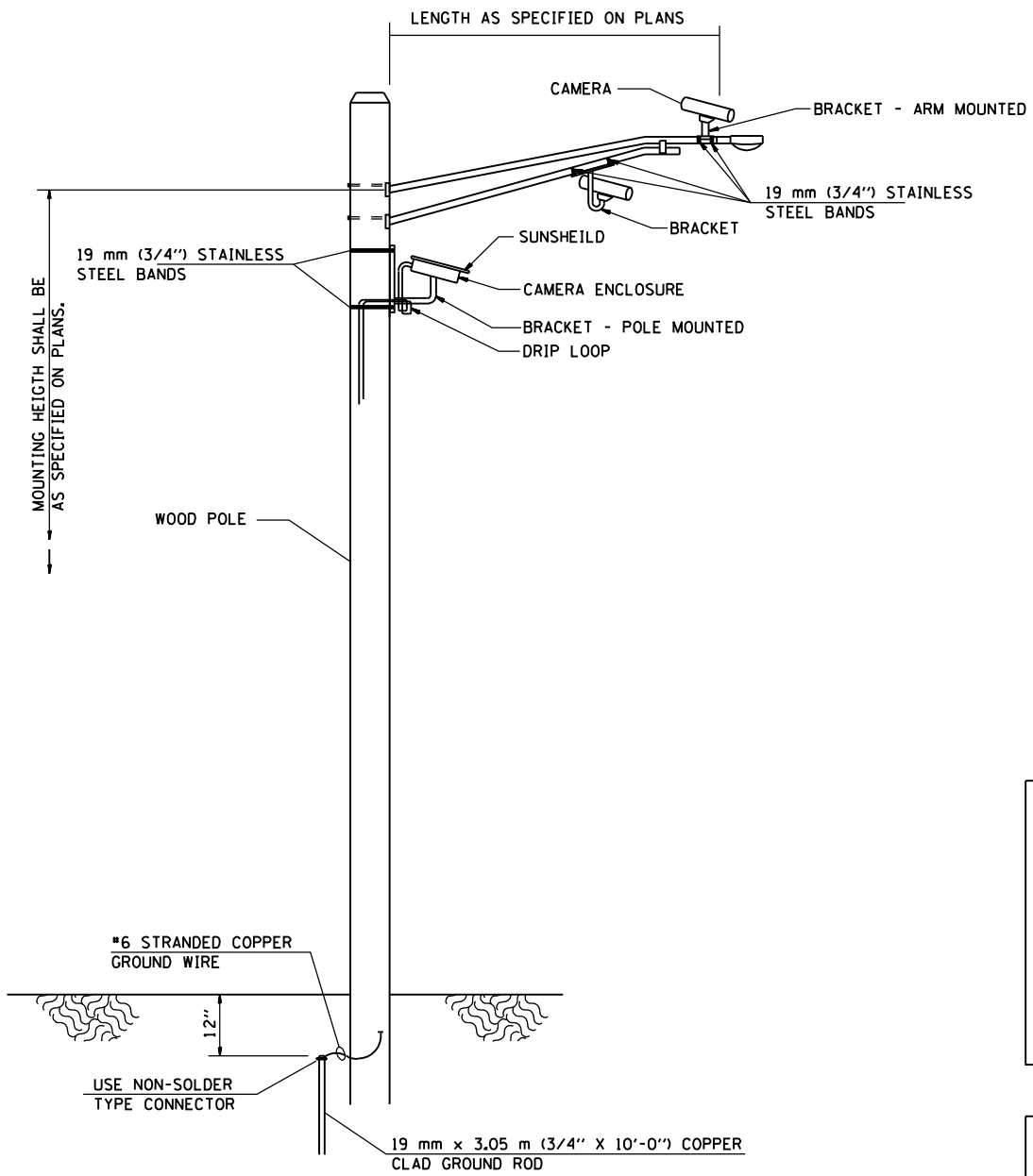

**VIDEO DETECTION SYSTEM INSTALLATION  
ARM MOUNTED OR POLE MOUNTED CAMERA**

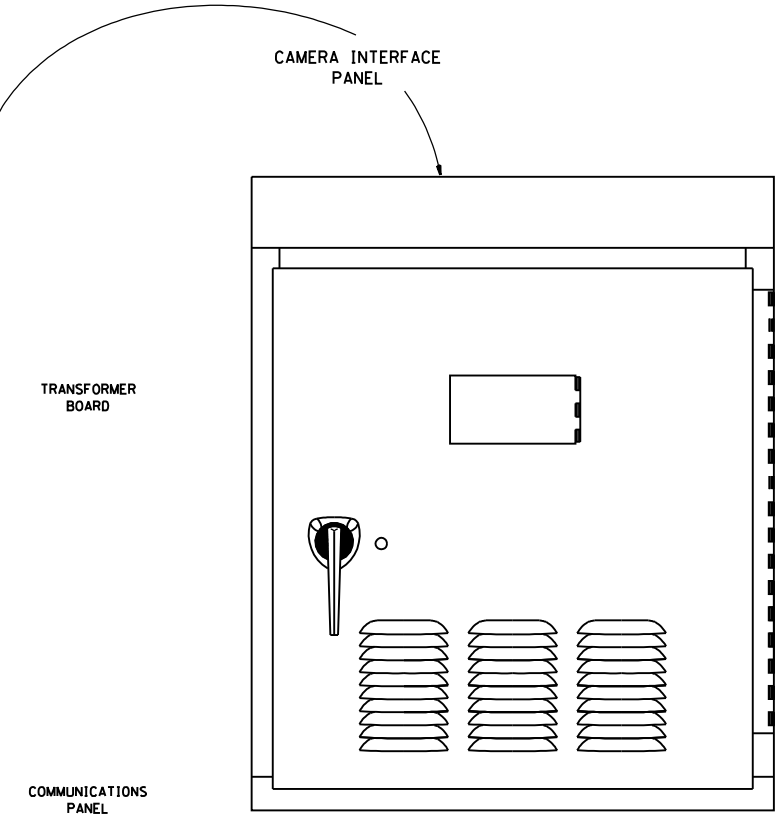
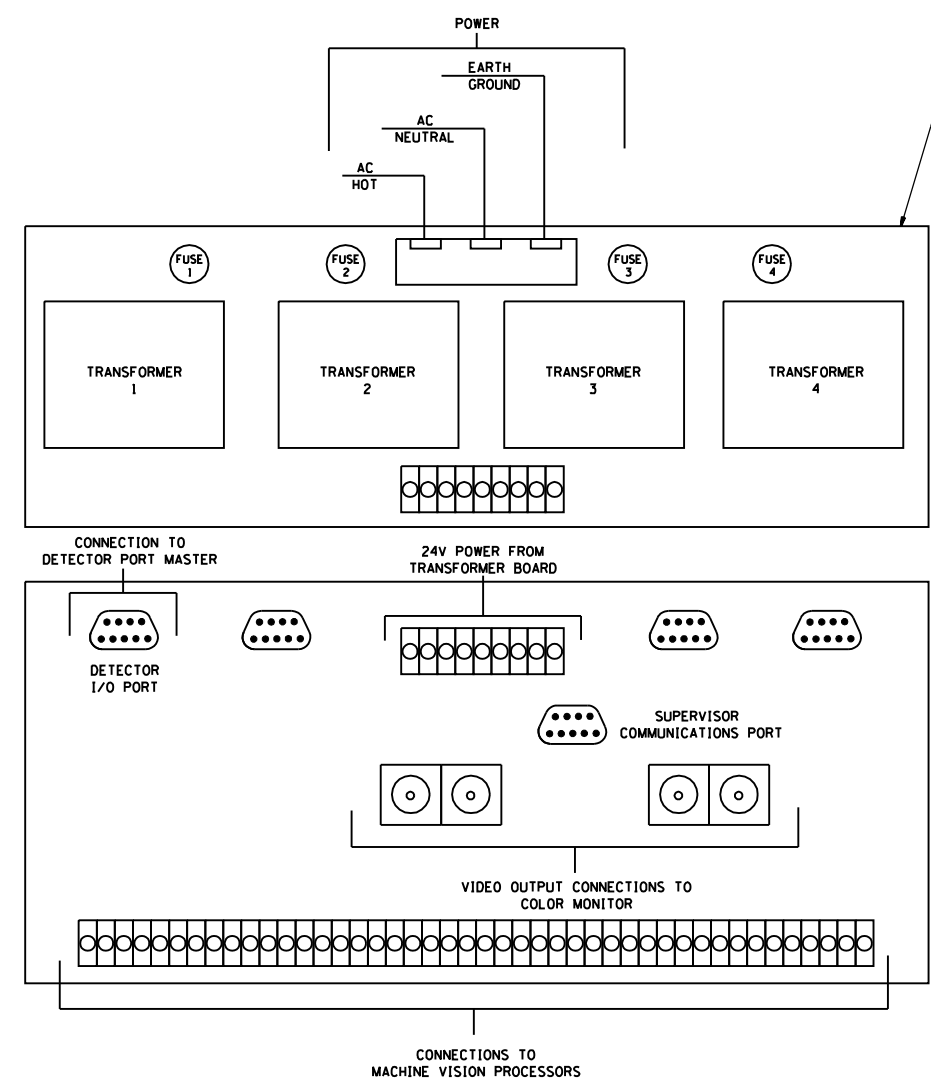
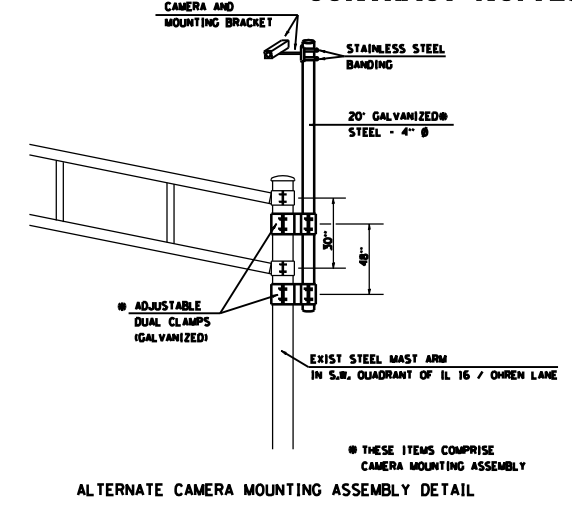
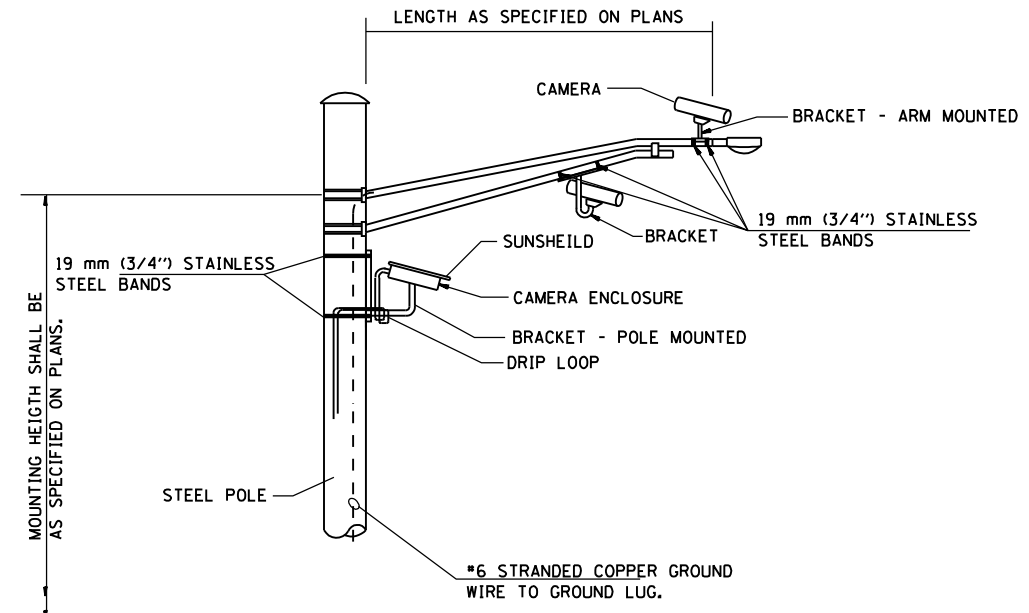

REVISIONS	
NAME	DATE
WCD	31OCT97

ILLINOIS DEPARTMENT OF TRANSPORTATION

**VIDEO DETECTION SYSTEM  
INSTALLATION DETAIL**

SCALE: VERT.    DRAWN BY: CADD  
 HORIZ.        CHECKED BY: WCD  
 DATE: MARCH 12, 1996