

F.A.P. RTE.	SECTION	COUNTY	TOTAL SHEETS	SHEET NO.
315	34-4	HANCOCK	452	264
FED. ROAD DIST. NO.		ILLINOIS FED. AID PROJECT		
D-98-591-02				

**CONTRACT NO. 72680**

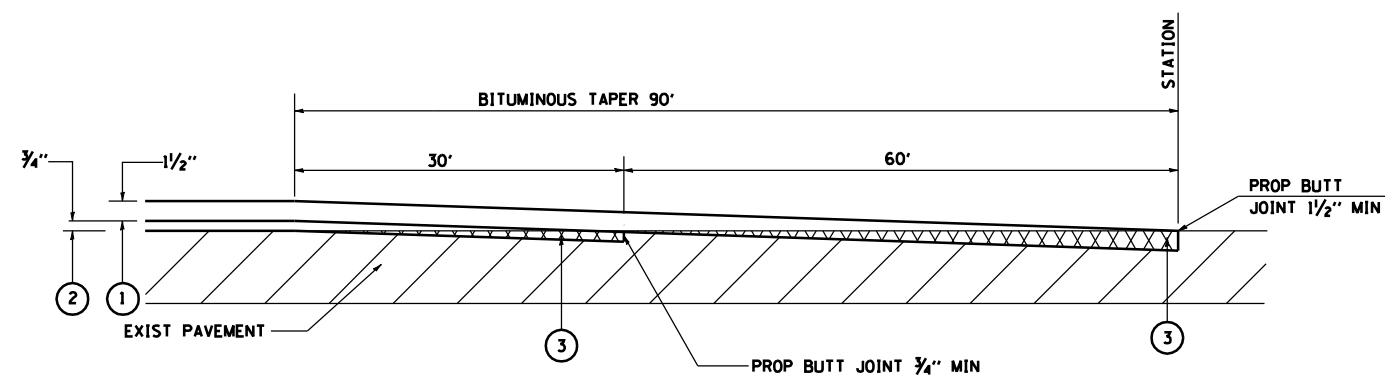

- LEGEND**
- ① PROPOSED BITUMINOUS SURFACE COURSE
  - ② PROPOSED LEVELING BINDER COURSE
  - ③ PROPOSED BITUMINOUS SURFACE REMOVAL - BUTT JOINT

**MAINLINE BUTT JOINT**  
STA 1150+43.87 EBL

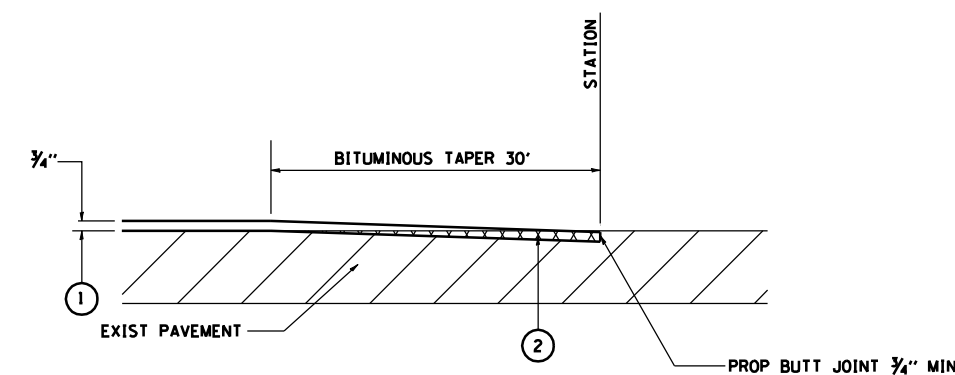

- LEGEND**
- ① PROPOSED LEVELING BINDER COURSE
  - ② PROPOSED BITUMINOUS SURFACE REMOVAL - BUTT JOINT

**MAINLINE BUTT JOINT**  
STA 1156+00.54 EBL  
STA 1174+00.00 EBL

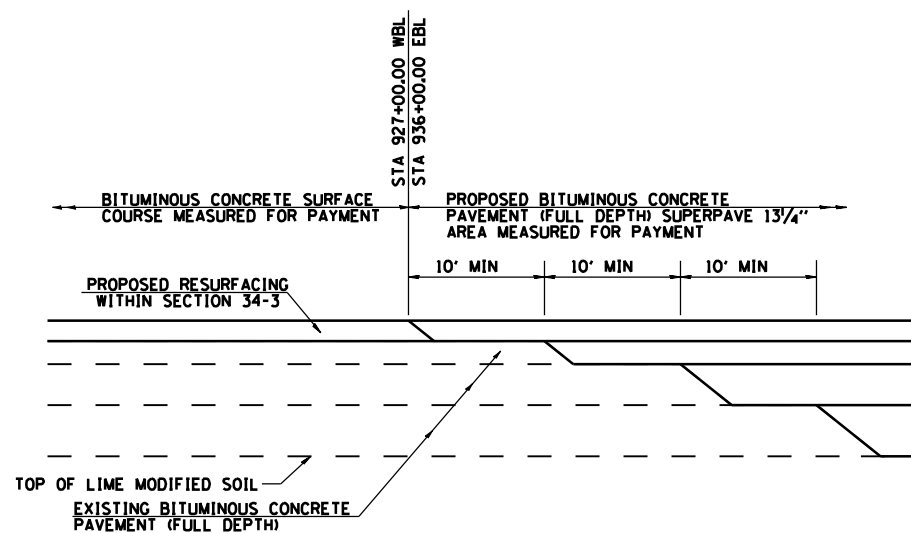

1. THE EXISTING TERMINATION SHALL BE CLEANED AND PRIMED AS DIRECTED BY THE ENGINEER.
2. PRIOR TO PLACING A SURFACE OR BINDER COURSE AT A FULL DEPTH PAVEMENT TERMINATION, THE CONTRACTOR SHALL SAW THE EDGE OF THE EXISTING COURSE AND REMOVE EXCESS BITUMINOUS MATERIAL AS DIRECTED BY THE ENGINEER. THE COST OF SAWING AND REMOVING THIS MATERIAL SHALL BE INCLUDED IN THE COST OF THE BITUMINOUS CONCRETE PAVEMENT (FULL DEPTH) OF THE TYPE AND THICKNESS SPECIFIED.
3. THE COST OF CLEANING, PRIMING AND REMOVING MATERIAL AT THE EXISTING TERMINATION SHALL BE INCLUDED IN THE COST OF THE BITUMINOUS CONCRETE PAVEMENT (FULL-DEPTH) OF THE TYPE AND THICKNESS SPECIFIED.

**DETAIL OF TERMINATION OF EXISTING FULL-DEPTH BITUMINOUS CONCRETE PAVEMENT AT WEST END**

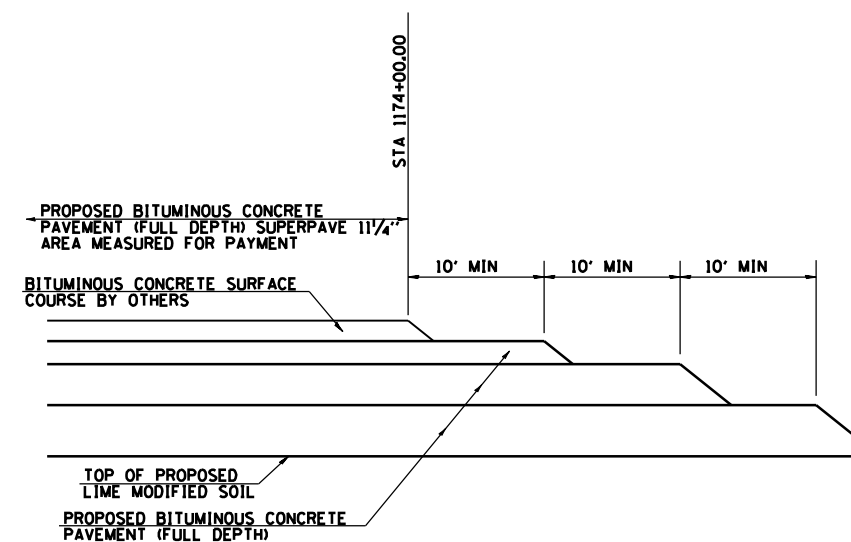

**DETAIL OF TERMINATION OF PROPOSED FULL-DEPTH BITUMINOUS CONCRETE PAVEMENT AT EAST END**

REVISIONS	
NAME	DATE

ILLINOIS DEPARTMENT OF TRANSPORTATION

**FAP ROUTE 315  
SPECIAL DETAILS  
BITUMINOUS BUTT JOINT  
PAVEMENT TERMINATION**

DATE 1/31/06  
DRAWN BY JCG  
CHECKED BY JRB