

ANCHOR BOLT DETAIL

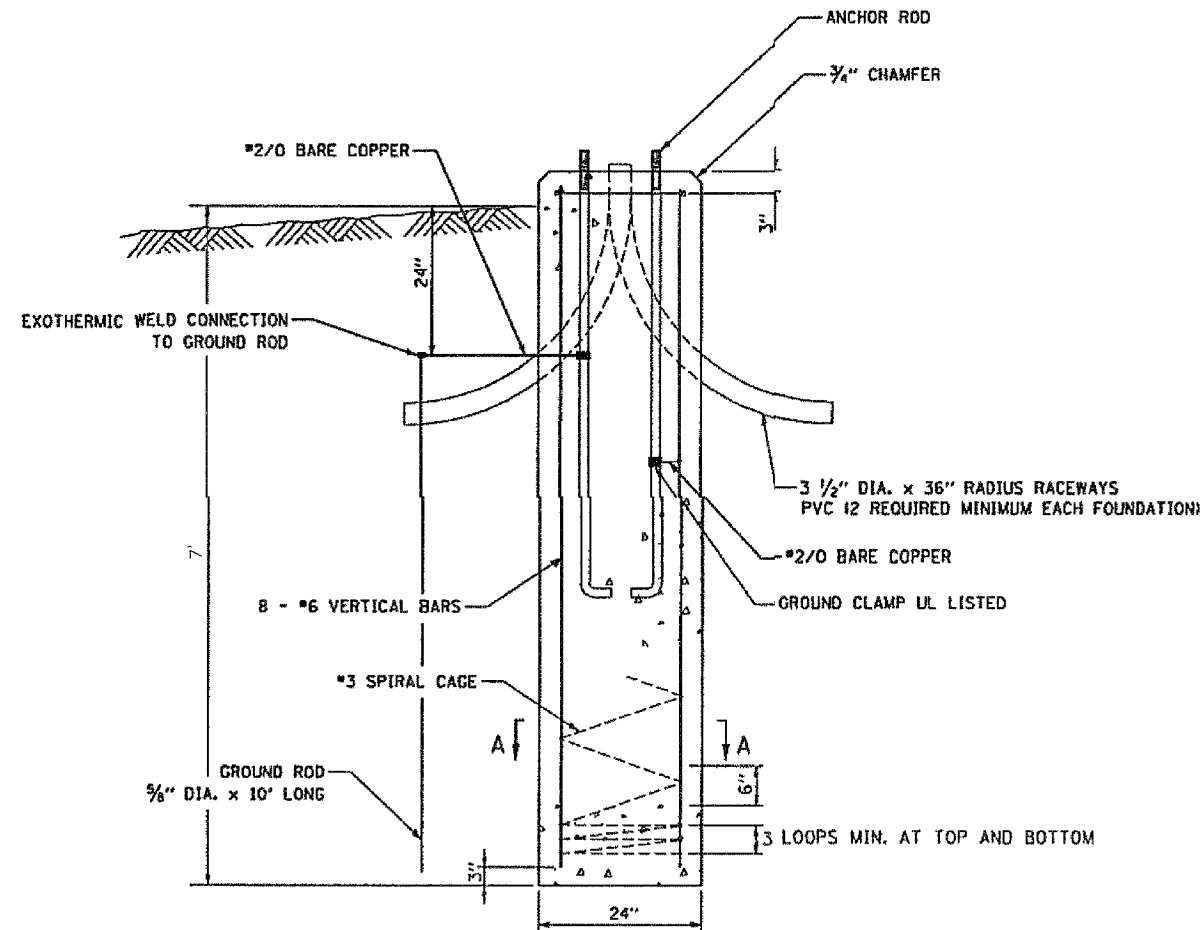

ROADWAY LIGHT POLE FOUNDATION

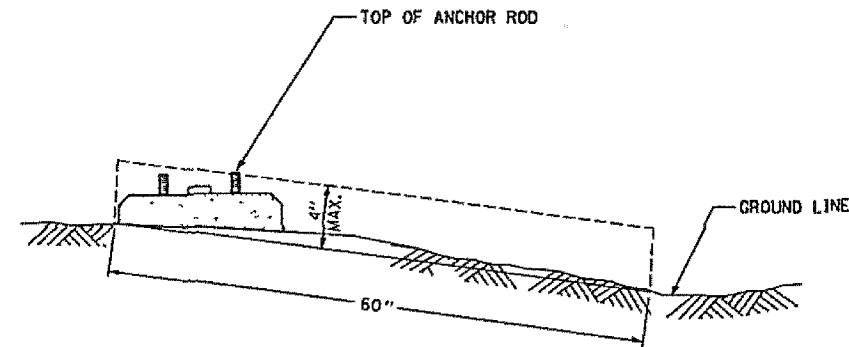

FOUNDATION EXTENSION DETAIL

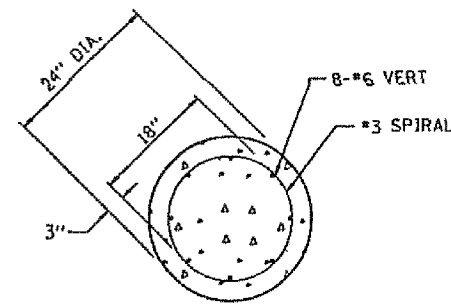

NOTES:

- ALL DIMENSIONS ARE SHOWN IN INCHES, UNLESS NOTED OTHERWISE.
- THE ANCHOR RODS AND RACEWAYS SHALL BE SECURED IN THE PROPER LOCATION BEFORE PLACEMENT OF THE CONCRETE.
- THE FOUNDATION SHALL NOT PROTRUDE MORE THAN 4 INCHES ABOVE THE FINISHED GRADE WITHIN A 60 INCH CHORD ACROSS THE FOUNDATION, WITH ANCHOR RODS INCLUDED, IN ACCORDANCE WITH AASHTO GUIDELINES. IF THE FOUNDATION HEIGHT, INCLUDING ANCHOR RODS, EXTENDS BEYOND THESE SPECIFIED LIMITS, THE FOUNDATION SHALL BE REPLACED AT THE CONTRACTOR'S EXPENSE. SEE FOUNDATION EXTENSION DETAIL.
- THE HOLE FOR THE FOUNDATION SHALL BE MADE BY DRILLING WITH AN AUGER OF THE SAME DIAMETER OF THE FOUNDATION. IF SOIL CONDITIONS REQUIRE THE USE OF A LINER TO FORM THE HOLE, THE LINER SHALL BE WITHDRAWN AS THE CONCRETE IS DEPOSITED.
- THE TOP OF THE FOUNDATION SHALL BE CONSTRUCTED LEVEL. A LINER OR FORM SHALL BE USED TO PRODUCE A UNIFORM SMOOTH SIDE TO THE TOP OF THE FOUNDATION. FOUNDATION TOP SHALL BE CHAMFERED 3/4 INCH.
- THE CONCRETE SHALL BE CLASS SI. CONCRETE SHALL CURE ACCORDING TO ARTICLE 1020.13 BEFORE LIGHT POLES ARE INSTALLED.
- THE ANCHOR ROD SHALL BE A HOOK ROD TYPE. COLD BENDING OF THE ANCHOR ROD WILL NOT BE ALLOWED. THE RADIUS OF THE HOOK BEND SHALL NOT BE LESS THAN FOUR TIMES THE NOMINAL DIAMETER OF THE ANCHOR ROD. A TACK WELDED ANCHOR ROD MAY BE SUBSTITUTED WITH THE APPROVAL OF THE ENGINEER.
- THE ANCHOR RODS SHALL BE ACCORDING TO ASTM F 1554 GRADE 105. NUTS SHALL BE HEXAGON NUTS ACCORDING TO ASTM A 194 2H OR ASTM A 563 DH, AND WASHERS SHALL BE ACCORDING TO ASTM F 436.
- ANCHOR RODS, NUTS, AND WASHERS SHALL BE COMPLETELY GALVANIZED BY EITHER HOT-DIPPED PROCESS CONFORMING TO AASHTO M 232, THE MECHANICAL PLATING METHOD CONFORMING TO AASHTO M 298, CLASS 50 WITH A MAXIMUM COATING THICKNESS OF 6 MILS, OR THE ELECTROLYTIC PROCESS ACCORDING TO AASHTO F 1136.
- THE ANCHOR RODS SHALL BE THREADED A MINIMUM OF 6 INCHES WITH A MINIMUM OF 3 INCHES OF THREADED ANCHOR ROD EMBEDDED IN THE FOUNDATION.
- ANCHOR RODS SHALL PROJECT 2 3/4" ABOVE THE TOP OF THE FOUNDATION. IF BREAKAWAY COUPLINGS ARE SPECIFIED, THE CONTRACTOR SHALL CAREFULLY COORDINATE THE ANCHOR ROD PROJECTION WITH THE INSTALLATION REQUIREMENTS OF THE BREAKAWAY COUPLINGS.
- THE CONTRACTOR SHALL USE A #3 SPIRAL AT 6" PITCH OR MAY SUBSTITUTE #3 TIES AT 12" ON CENTER WITH APPROVAL OF THE ENGINEER.
- THE CABLE TRENCHES AND FOUNDATIONS SHALL BE BACKFILLED AND COMPACTED AS SPECIFIED BEFORE THE LIGHT POLE IS ERECTED.
- THE RACEWAYS SHALL PROJECT 1" ABOVE THE TOP OF THE FOUNDATION.

Ciorba Group, Inc.
CONSULTING ENGINEERS
5507 North Cumberland Avenue, Suite 402 Chicago, Illinois 60656
Tel. 773.775.4006 Fax 773.775.4014 Email chicago@ciorba.com

VILLAGE OF MOKENA
LAPORTE ROAD REHABILITATION

LIGHTING DETAILS

DESIGN: KDM
DRAWN: KDM
CHECKED: JMV

DATE: DEC. 2005
SCALE: NONE
FILE NO.: 3232