

FAM. SITE:	SECTION	COUNTY	TOTAL SHEETS	SHEET NO.
1585	02-00079-00-LT	COOK	9	5
STA.		TO STA.		
FED. ROAD DIST. NO.	ILLINOIS	FED. AID PROJECT		

**CONTROLLER #1**  
240/480V, 1Ø, 3 WIRE, 60 HZ.

CIRCUIT	WATTS	AMPS
A	580	2.60
B	580	2.60
C	1160	5.20
D	870	3.90
<b>TOTAL LOAD</b>	<b>3190</b>	<b>14.30</b>

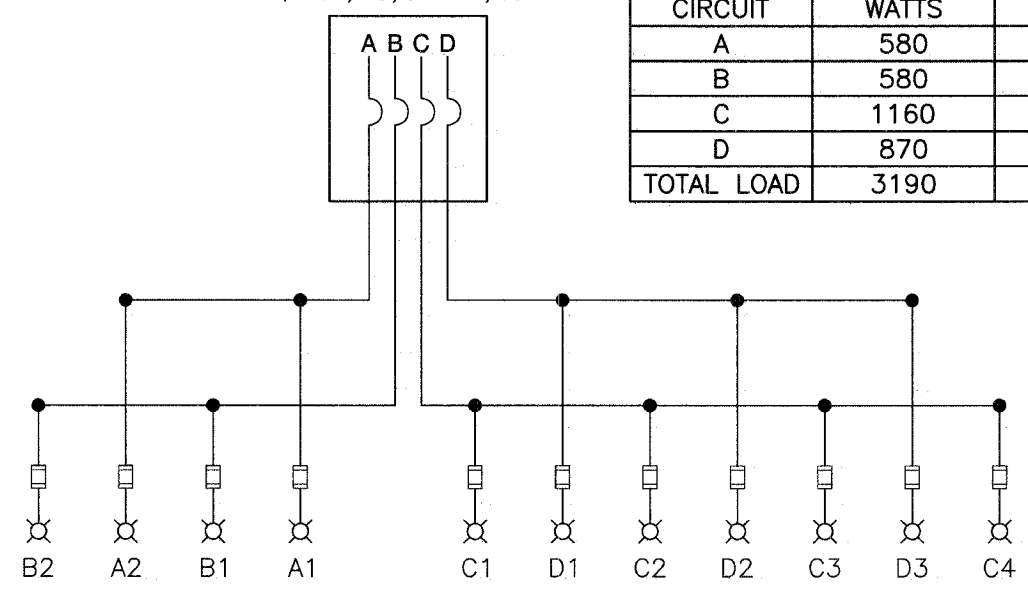

**SINGLE LINE LEGEND**

- ⊗ LUMINAIRE, 250W HPS, STREET LIGHT
- FUSE, 3.5 AMP
- ⌋ CIRCUIT BREAKER
- CONNECTION

<p><b>ROBINSON ENGINEERING, LTD.</b> CONSULTING REGISTERED PROFESSIONAL ENGINEERS AND PROFESSIONAL LAND SURVEYORS 17000 SOUTH PARK AVENUE SOUTH HOLLAND, ILLINOIS 60473 (708) 331-6700 FAX (708) 331-3826 © COPYRIGHT 2005</p>		<p><b>REVISIONS</b></p> <table border="1"> <thead> <tr> <th>No.</th> <th>Date</th> <th>Remarks</th> </tr> </thead> <tbody> <tr><td> </td><td> </td><td> </td></tr> <tr><td> </td><td> </td><td> </td></tr> <tr><td> </td><td> </td><td> </td></tr> <tr><td> </td><td> </td><td> </td></tr> <tr><td> </td><td> </td><td> </td></tr> <tr><td> </td><td> </td><td> </td></tr> <tr><td> </td><td> </td><td> </td></tr> <tr><td> </td><td> </td><td> </td></tr> <tr><td> </td><td> </td><td> </td></tr> <tr><td> </td><td> </td><td> </td></tr> </tbody> </table>		No.	Date	Remarks																														
No.	Date	Remarks																																		
<p>119TH STREET STREET LIGHTING SINGLE LINE WIRING DIAGRAM</p>																																				
<p><b>ALSIP, ILLINOIS</b></p>		<p>Drawn by: RM Date: 12/20/05 Checked by: TRL/PAP Scale: NONE Sheet 5 of 9 Project No. 02-160.02</p>																																		