

F.A. RTE.	SECTION	COUNTY	TOTAL SHEETS	SHEET NO.
*		McHENRY	22	22
STA.	TO STA.			
FED. ROAD DIST. NO.	ILLINOIS FED. AID PROJECT			
* D1-00101-00-TL				
CONTRACT NO. 83844				

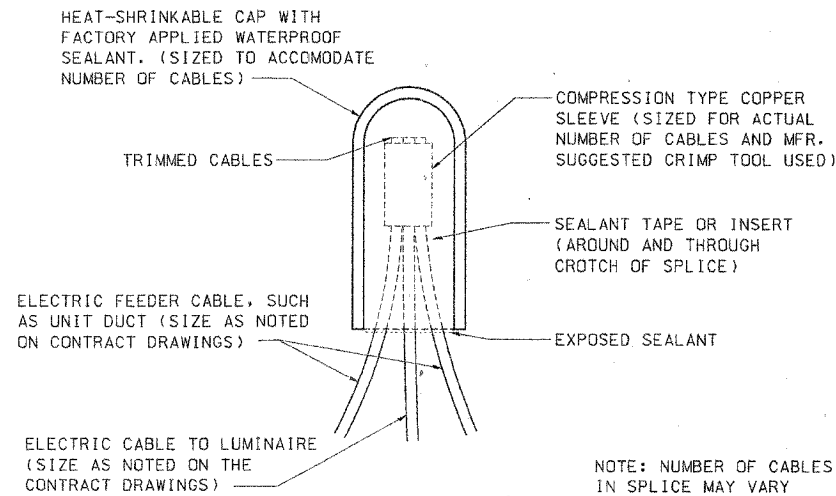

SPLICING ELECTRIC CABLE

NOTE: NUMBER OF CABLES IN SPLICE MAY VARY

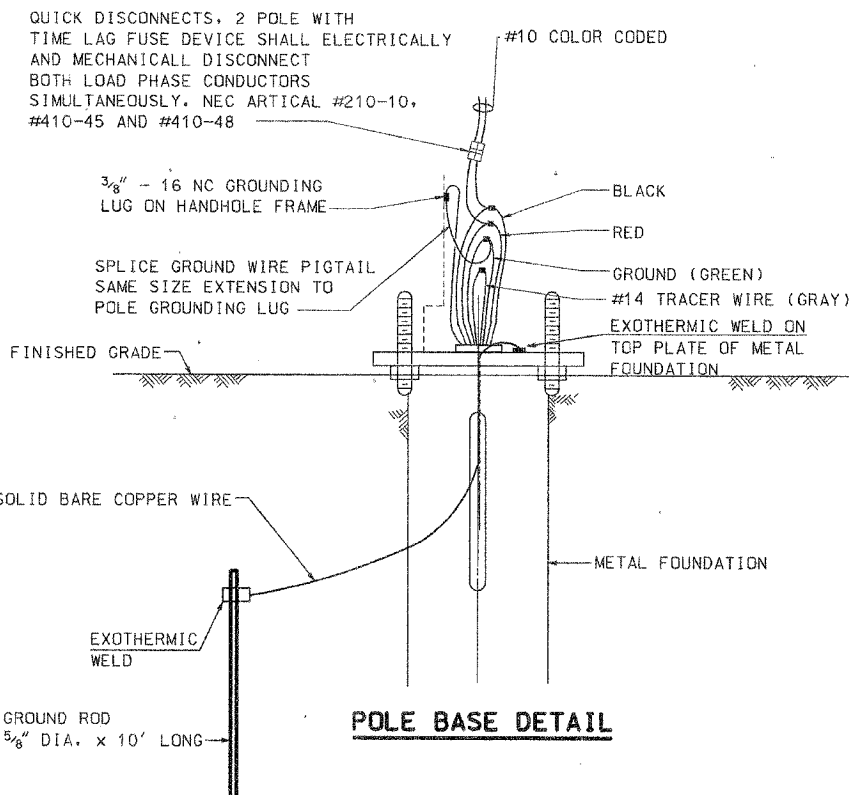

POLE BASE DETAIL

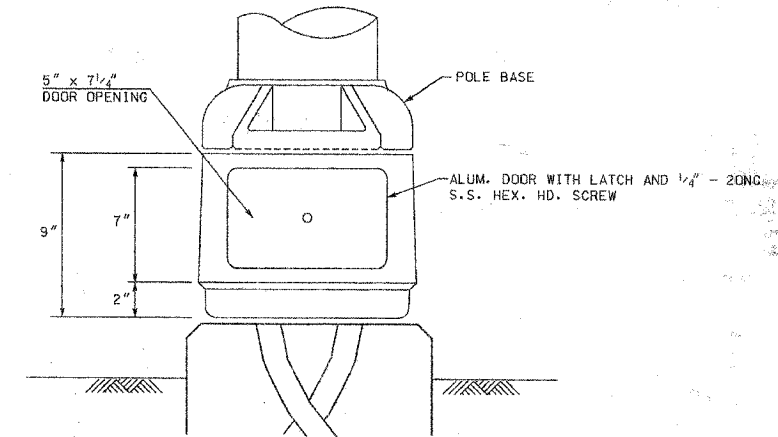

BREAKAWAY DEVICE, TRANSFORMER BASE
THE BREAKAWAY TRANSFORMER BASE SHALL HAVE A LISTING OF APPROVAL BY FHWA COMPLIANCE TO 1985 AASHTO REQUIREMENTS.

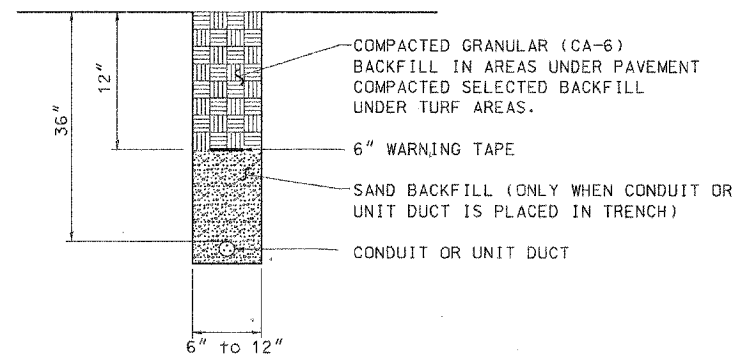

TRENCH AND BACKFILL

THIS DRAWING IS THE EXCLUSIVE PROPERTY OF SUNJOY INC. AND IS PROVIDED ONLY FOR THE PROJECT LISTED ON THIS DRAWING. THIS DRAWING SHALL NOT BE DUPLICATED, USED OR DISCLOSED, IN WHOLE OR IN PART, FOR ANY PURPOSE WHATSOEVER WITHOUT THE WRITTEN PERMISSION OF SUNJOY INC.



Sunjoy Inc.
Area Lighting
212 TIMBERCREST DRIVE
SCHALMBURG, ILLINOIS
60193-1572

McHENRY COUNTY DIVISION OF TRANSPORTATION
CITY OF CRYSTAL LAKE
INTERSECTION OF GOLF COURSE ROAD
WITH ACKMAN ROAD

LIGHT POLE FOUNDATION AND ELECTRICAL DETAILS

SCALE: NONE
DATE: NOV. 23, 2005

DRAWN BY HKQ
CHECKED BY JS