

F.A.I. RTE.	SECTION	COUNTY	TOTAL SHEETS	SHEET NO.
57	*	**	7	7

STA. \_\_\_\_\_ TO STA. \_\_\_\_\_

FED. ROAD DIST. NO. ILLINOIS FED. AID PROJECT

- \* SECTION GPS MONUMENT SETTINGS FY06
- \*\* JEFFERSON AND WILLIAMSON COUNTIES

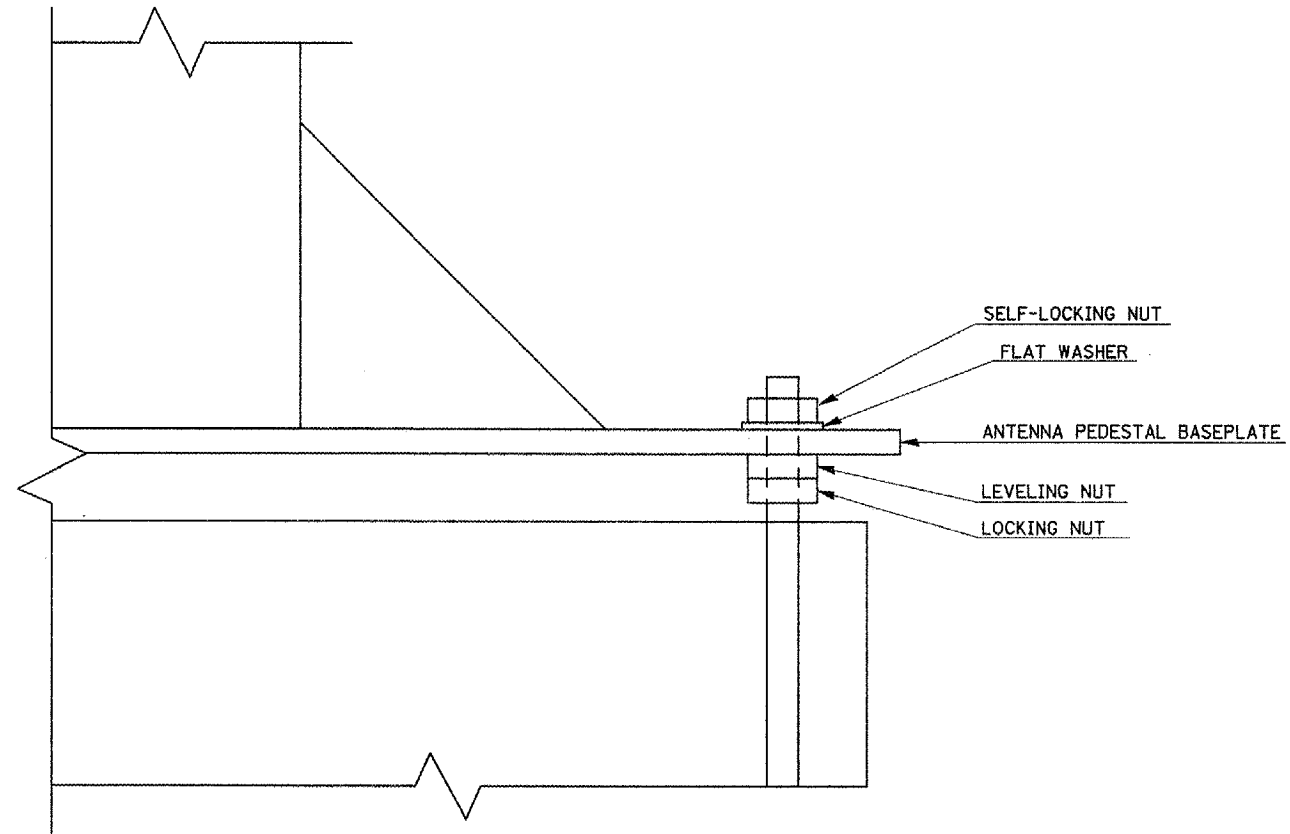

**NOTES**

- \* NUTS AND WASHERS SHALL BE GALVANIZED STEEL
- \* ANTENNA PEDESTAL SHALL BE LEVELED USING LEVELING NUTS AND SECURED USING THE LOCKING NUTS

REVISIONS	
NAME	DATE

ILLINOIS DEPARTMENT OF TRANSPORTATION

**PEDESTAL LEVELING DETAILS**

SCALE: VERT. \_\_\_\_\_  
 HORIZ. \_\_\_\_\_  
 DATE \_\_\_\_\_ DRAWN BY \_\_\_\_\_  
 CHECKED BY \_\_\_\_\_

PLT DATE = 2/15/2008  
 FILE NAME = s:\p\m\m\9802981\9802981.dgn  
 USER NAME = evanston