

RETURN WITH BID

LETTING DATE April 28, 2006

ITEM NUMBER 3A

Proposal Submitted By

Name

Address

City/State

Zip Code

Telephone Number

FEIN Number

FAX Number

BIDDERS NEED NOT RETURN THE ENTIRE PROPOSAL
(See instructions inside front cover)

NOTICE TO PROSPECTIVE BIDDERS

This proposal can be used for bidding purposes
by only those companies that request and receive written
AUTHORIZATION TO BID from IDOT's Central Bureau of
Construction.
(SEE INSTRUCTIONS ON THE INSIDE OF COVER)

PROPOSAL COVER SHEET



Illinois Department of Transportation
DIVISION OF AERONAUTICS

AIRPORT Aurora Municipal

MUNICIPAL DESIGNATION Aurora

COUNTY DESIGNATION Kane

ILLINOIS PROJECT NO. ARR-3468

FEDERAL PROJECT NO. 3-17-0003-B31

PLEASE MARK THE APPROPRIATE BOX BELOW:

A Bid Bond is included.

A Cashier's Check or a Certified Check is included.

INSTRUCTIONS

ABOUT IDOT PROPOSALS: All proposals issued by IDOT are potential bidding proposals. Each proposal contains all Certifications and Affidavits, a Proposal Signature Sheet and a Proposal Bid Bond required for Prime Contractors to submit a bid after written **Authorization to Bid** has been issued by IDOT’s Central Bureau of Construction.

HOW MANY PROPOSALS SHOULD PROSPECTIVE BIDDERS REQUEST?: Prospective bidders should, prior to submitting their initial request for plans and proposals, determine their needs and request the total number of plans and proposals needed for each item requested. There will be a nonrefundable charge of \$15 for each set of plans and specifications issued.

WHO CAN BID?: Bids will be accepted from only those companies that request and receive written **Authorization to Bid** from IDOT’s Central Bureau of Construction.

WHAT CONSTITUTES WRITTEN AUTHORIZATION TO BID?: When a prospective prime bidder submits a “Request for Proposal Forms and Plans” he/she must indicate at that time which items are being requested For Bidding purposes. Only those items requested For Bidding will be analyzed. After the request has been analyzed, the bidder will be issued a **Proposal Denial and/or Authorization Form**, approved by the Central Bureau of Construction, that indicates which items have been approved For Bidding. If **Authorization to Bid** cannot be approved, the **Proposal Denial and/or Authorization Form** will indicate the reason for denial. If a contractor has requested to bid but has not received a **Proposal Denial and/or Authorization Form**, they should contact the Central Bureau of Construction in advance of the letting date.

WHAT MUST BE INCLUDED WHEN BIDS ARE SUBMITTED?: Bidders need not return the entire proposal when bids are submitted. That portion of the proposal that must be returned includes the following:

1. All documents from the Proposal Cover Sheet through the Proposal Bid Bond
2. Other special documentation and/or information that may be required by the contract special provisions

All proposal documents, including Proposal Guaranty Checks or Proposal Bid Bonds, should be stapled together to prevent loss when bids are processed by IDOT personnel.

ABOUT SUBMITTING BIDS: It is recommended that bidders deliver bids in person to insure they arrive at the proper location prior to the time specified for the receipt of bids. Any bid received at the place of letting after the time specified will not be accepted.

WHO SHOULD BE CALLED IF ASSISTANCE IS NEEDED?

Questions Regarding	Call
Prequalification and/or Authorization to Bid	217/782-3413
Preparation and submittal of bids	217/782-7806
Mailing of plans and proposals	217/782-7806



1. Proposal of _____

Taxpayer Identification Number (Mandatory) _____

for the improvement officially known as:

- (a) Aurora Municipal Airport
- (b) The proposed improvement shown in detail on the plans issued by the Department schedule and detail sheets included herein, includes, in general, the following described work:

Construct Runway 33 instrument landing system; Relocate Runway 9 localizer.

TO THE DEPARTMENT OF TRANSPORTATION

2. The plans for the proposed work are those issued by the Department of Transportation to cover the work described above.

The specifications are those prepared by the Department of Transportation, Division of Aeronautics and designated as "Standard Specifications for Construction of Airports," adopted January, 1985, the "Supplemental Specifications and Recurring Special Provisions," adopted July 1, 2004 and the "Special Provisions" thereto, adopted and in effect on the date of invitation for bids.

3. **COMPLETION TIME/LIQUIDATED DAMAGES.** It being understood and agreed that the completion within the time limit is an essential part of the contract, the bidder agrees to complete the work within 107 calendar days, unless additional time is granted by the Engineer in accordance with the provisions of the specifications. In case of failure to complete the work on or before the time named herein, or within such extra time as may have been allowed by extensions, the bidder agrees that the Department of Transportation shall withhold from such sum as may be due him/her under the terms of this contract, the costs, as set forth below, which costs shall be considered and treated not as a penalty but as damages due to the State from the bidder by reason of the failure of the bidder to complete the work within the time specified in the contract. The following Schedule of Deductions supersedes the table given in Section 60-09 of the Division's Standard Specifications for Construction of Airports.

Schedule of Deductions for Each Day of Overrun in Contract Time

<u>Original Contract Amount</u>		<u>Daily Charge</u>
<u>From More Than</u>	<u>To and Including</u>	<u>Calendar Day</u>
\$ 0	\$ 25,000	\$ 300
25,000	100,000	375
100,000	500,000	550
500,000	1,000,000	725
1,000,000	2,000,000	900
2,000,000	3,000,000	1,100
3,000,000	5,000,000	1,300
5,000,000	7,500,000	1,450
7,500,000	10,000,000	1,650

A daily charge shall be made for every day shown on the calendar beyond the specified contract time in calendar days.

RETURN WITH BID

4. **ASSURANCE OF EXAMINATION AND INSPECTION/WAIVER.** The undersigned further declares that he/she has carefully examined the proposal, plans, specifications, supplemental and applicable recurring special provisions, form of contract and contract bonds, and special provisions, and that he/she has inspected in detail the site of the proposed work, and that he/she has familiarized themselves with all of the local conditions affecting the contract and the detailed requirements of construction, and understands that in making this proposal he/she waives all right to plead any misunderstanding regarding the same.

5. **EXECUTION OF CONTRACT AND CONTRACT BONDS.** The undersigned further agrees to execute a contract for this work and present the same to the department within fifteen (15) days after the contract has been mailed to him/her. The undersigned further agrees that he/she and his/her surety will execute and present within fifteen (15) days after the contract has been mailed to him/her contract bonds satisfactory to and in the form prescribed by the Department of Transportation, in the penal sum of the full amount of the contract, guaranteeing the faithful performance of the work in accordance with the terms of the contract and guaranteeing payment in full all bills and accounts for materials and labor used in the construction of the work.

6. **PROPOSAL GUARANTY.** Accompanying this proposal is either a bid bond on the department form, executed by a corporate surety company satisfactory to the department, or a proposal guaranty check consisting of a bank cashier's check or a properly certified check for not less than 5 per cent of the amount bid or for the amount specified in the following schedule:

<u>Amount of Bid</u>	<u>Proposal Guaranty</u>	<u>Amount of Bid</u>	<u>Proposal Guaranty</u>
Up to \$5,000	to \$5,000\$150	\$2,000,000	to \$3,000,000 \$100,000
\$5,000	to \$10,000\$300	\$3,000,000	to \$5,000,000 \$150,000
\$10,000	to \$50,000\$1,000	\$5,000,000	to \$7,500,000 \$250,000
\$50,000	to \$100,000\$3,000	\$7,500,000	to \$10,000,000 \$400,000
\$100,000	to \$150,000\$5,000	\$10,000,000	to \$15,000,000 \$500,000
\$150,000	to \$250,000\$7,500	\$15,000,000	to \$20,000,000 \$600,000
\$250,000	to \$500,000\$12,500	\$20,000,000	to \$25,000,000\$700,000
\$500,000	to \$1,000,000\$25,000	\$25,000,000	to \$30,000,000 \$800,000
\$1,000,000	to \$1,500,000\$50,000	\$30,000,000	to \$35,000,000 \$900,000
\$1,500,000	to \$2,000,000\$75,000	over	\$35,000,000 \$1,000,000

Bank cashier's checks or properly certified checks accompanying proposals shall be made payable to the Treasurer, State of Illinois, when the state is awarding authority; the county treasurer, when a county is the awarding authority; or the city, village, or town treasurer, when a city, village, or town is the awarding authority.

If a combination bid is submitted, the proposal guaranties which accompany the individual proposals making up the combination will be considered as also covering the combination bid.

The amount of the proposal guaranty check is _____ \$(). If this proposal is accepted and the undersigned shall fail to execute contract bonds as required herein, it is hereby agreed that the amount of the proposal guaranty shall become the property of the State of Illinois, and shall be considered as payment of damages due to delay and other causes suffered by the State because of the failure to execute said contract and contract bonds; otherwise, the bid bond shall become void or the proposal guaranty check shall be returned to the undersigned.

RETURN WITH BID

(e) The plans and Special Provisions for each separate contract shall be construed separately for all requirements, except as described in paragraphs (a) through (d) listed above.

When a combination bid is submitted, the schedule below must be completed in each proposal comprising the combination.

If alternate bids are submitted for one or more of the sections comprising the combination, a combination bid must be submitted for each alternate.

Schedule of Combination Bids

Combination No.	Sections Included in Combination	Combination Bid	
		Dollars	Cents

8. **SCHEDULE OF PRICES.** The undersigned submits herewith his/her schedule of prices covering the work to be performed under this contract; he/she understands that he/she must show in the schedule the unit prices (with no more than two decimal places, i.e. \$25.35, not \$25.348) for which he/she proposes to perform each item of work, that the extensions must be made by him/her, and that if not so done his/her proposal may be rejected as irregular.

The undersigned further agrees that the unit prices submitted herewith are for the purpose of obtaining a gross sum, and for use in computing the value of additions and deductions; that if there is a discrepancy between the gross sum bid and that resulting from the summation of the quantities multiplied by their respective unit prices, the latter shall govern.

STATE JOB #- - - -

ILLINOIS DEPARTMENT OF TRANSPORTATION
 SCHEDULE OF PRICES
 CONTRACT NUMBER - AU062

ECMS002 DTGECM03 ECMR003 PAGE 1
 RUN DATE - 03/23/06
 RUN TIME - 203144

COUNTY NAME	CODE	DIST	AIRPORT NAME	FED PROJECT	ILL PROJECT
KANE	089	01	AURORA MUNICIPAL	3-17-0003-B31	AR-R -3468

ITEM NUMBER	PAY ITEM DESCRIPTION	UNIT OF MEASURE	QUANTITY	UNIT PRICE		TOTAL PRICE	
				DOLLARS	CENTS	DOLLARS	CTS
AR108082	1/C #2 XLP-USE	L.F.	285.000 X		=		
AR110212	2" STEEL DUCT, DIRECT BURY	L.F.	130.000 X		=		
AR110214	4" STEEL DUCT, DIRECT BURY	L.F.	76.000 X		=		
AR110314	4" STEEL DUCT, JACKED	L.F.	172.000 X		=		
AR110550	SPLIT DUCT	L.F.	18.000 X		=		
AR125565	SPLICE CAN	EACH	2.000 X		=		
AR125907	REMOVE REILS	PAIR	1.000 X		=		
AR125942	ADJUST BASE MOUNTED LIGHT	EACH	8.000 X		=		
AR125968	RELOCATE PAPI	EACH	1.000 X		=		
AR127410	LOCALIZER	L.S.	1.000 X		=		
AR127415	DME	L.S.	1.000 X		=		
AR127420	GLIDESLOPE	L.S.	1.000 X		=		
AR127430	SHELTER BUILDING	EACH	4.000 X		=		
AR127450	MALSR INSTALLATION	L.S.	1.000 X		=		
AR127903	REMOVE SHELTER BUILDING	EACH	1.000 X		=		

AURORA MUNICIPAL
KANE

ILLINOIS DEPARTMENT OF TRANSPORTATION
SCHEDULE OF PRICES
CONTRACT NUMBER - AU062

ECMS002 DTGECM03 ECMR003 PAGE 2
RUN DATE - 03/23/06
RUN TIME - 203144

ITEM NUMBER	PAY ITEM DESCRIPTION	UNIT OF MEASURE	QUANTITY	UNIT PRICE		TOTAL PRICE	
				DOLLARS	CENTS	DOLLARS	CTS
AR127961	RELOCATE LOCALIZER	L.S.	1.000 X		=		
AR150510	ENGINEER'S FIELD OFFICE	L.S.	1.000 X		=		
AR151410	CLEARING	ACRE	0.500 X		=		
AR152410	UNCLASSIFIED EXCAVATION	C.Y.	6,230.000 X		=		
AR156510	SILT FENCE	L.F.	5,000.000 X		=		
AR156513	SEPARATION FABRIC	S.Y.	8,675.000 X		=		
AR156520	INLET PROTECTION	EACH	3.000 X		=		
AR162506	CLASS E FENCE 6'	L.F.	410.000 X		=		
AR162716	ELECTRIC GATE-16'	EACH	1.000 X		=		
AR209606	CRUSHED AGG. BASE COURSE - 6"	S.Y.	1,685.000 X		=		
AR209608	CRUSHED AGG. BASE COURSE - 8"	S.Y.	6,990.000 X		=		
AR401610	BITUMINOUS SURFACE COURSE	TON	100.000 X		=		
AR602510	BITUMINOUS PRIME COAT	GAL.	90.000 X		=		
AR620520	PAVEMENT MARKING-WATERBORNE	S.F.	38,100.000 X		=		
AR620525	PAVEMENT MARKING-BLACK BORDER	S.F.	7,525.000 X		=		

AURORA MUNICIPAL
KANE

ILLINOIS DEPARTMENT OF TRANSPORTATION
SCHEDULE OF PRICES
CONTRACT NUMBER - AU062

ECMS002 DTGECM03 ECMR003 PAGE 3
RUN DATE - 03/23/06
RUN TIME - 203144

ITEM NUMBER	PAY ITEM DESCRIPTION	UNIT OF MEASURE	QUANTITY	UNIT PRICE		TOTAL PRICE	
				DOLLARS	CENTS	DOLLARS	CTS
AR701218	18" CMP	L.F.	47.000 X		=		
AR701224	24" CMP	L.F.	72.000 X		=		
AR701900	REMOVE PIPE	L.F.	117.000 X		=		
AR705900	REMOVE UNDERDRAIN	L.F.	50.000 X		=		
AR752218	METAL END SECTION 18"	EACH	2.000 X		=		
AR752224	METAL END SECTION 24"	EACH	4.000 X		=		
AR800025	3 1/C #4 XLP-USE, 1/C #8 GND.	L.F.	185.000 X		=		
AR800030	ILS POWER MODIFICATIONS	L.S.	1.000 X		=		
AR800033	TREE CLEARING AND GRUBBING (6"-15 IN-DIA		12.000 X		=		
AR800034	TREE CLEARING AND GRUBBING (+15") IN-DIA		165.000 X		=		
AR800101	DELINEATOR	EACH	3.000 X		=		
AR800119	REMOVE GRAVEL	C.Y.	1,440.000 X		=		
AR800123	CABLE BARRIER GATE	EACH	1.000 X		=		
AR800124	ADJUST GLIDESLOPE	L.S.	1.000 X		=		
AR800127	RELOCATE GATE	EACH	1.000 X		=		

AURORA MUNICIPAL
KANE

ILLINOIS DEPARTMENT OF TRANSPORTATION
SCHEDULE OF PRICES
CONTRACT NUMBER - AU062

ECMS002 DTGECM03 ECMR003 PAGE 4
RUN DATE - 03/23/06
RUN TIME - 203144

ITEM NUMBER	PAY ITEM DESCRIPTION	UNIT OF MEASURE	QUANTITY	UNIT PRICE		TOTAL PRICE	
				DOLLARS	CENTS	DOLLARS	CTS
AR800145	LOCALIZER GROUND CHECK POINT	EACH	6.000 X			=	
AR800158	3-1/C #6 XLP-USE 600V, 1/C #8 GND	L.F.	950.000 X			=	
AR901510	SEEDING	ACRE	43.000 X			=	
AR908510	MULCHING	ACRE	43.000 X			=	
AR910420	BOLLARD	EACH	8.000 X			=	
TOTAL						\$	

NOTE:

1. EACH PAY ITEM SHOULD HAVE A UNIT PRICE AND A TOTAL PRICE.
2. THE UNIT PRICE SHALL GOVERN IF NO TOTAL PRICE IS SHOWN OR IF THERE IS A DISCREPANCY BETWEEN THE PRODUCT OF THE UNIT PRICE MULTIPLIED BY THE QUANTITY.
3. IF A UNIT PRICE IS OMITTED, THE TOTAL PRICE WILL BE DIVIDED BY THE QUANTITY IN ORDER TO ESTABLISH A UNIT PRICE.
4. A BID MAY BE DECLARED UNACCEPTABLE IF NEITHER A UNIT PRICE NOR A TOTAL PRICE IS SHOWN.

RETURN WITH BID

THE PRECEDING SCHEDULE OF PRICES MUST BE

COMPLETED AND RETURNED.

RETURN WITH BID

**STATE REQUIRED ETHICAL
STANDARDS GOVERNING CONTRACT
PROCUREMENT: ASSURANCES, CERTIFICATIONS
AND DISCLOSURES**

I. GENERAL

A. Article 50 of the Illinois Procurement Code establishes the duty of all State chief procurement officers, State purchasing officers, and their designees to maximize the value of the expenditure of public moneys in procuring goods, services, and contracts for the State of Illinois and to act in a manner that maintains the integrity and public trust of State government. In discharging this duty, they are charged by law to use all available information, reasonable efforts, and reasonable actions to protect, safeguard, and maintain the procurement process of the State of Illinois.

B. In order to comply with the provisions of Article 50 and to carry out the duty established therein, all bidders are to adhere to ethical standards established for the procurement process, and to make such assurances, disclosures and certifications required by law. By execution of the Proposal Signature Sheet, the bidder indicates that each of the mandated assurances has been read and understood, that each certification is made and understood, and that each disclosure requirement has been understood and completed.

C. In addition to all other remedies provided by law, failure to comply with any assurance, failure to make any disclosure or the making of a false certification shall be grounds for termination of the contract and the suspension or debarment of the bidder.

II. ASSURANCES

A. The assurances hereinafter made by the bidder are each a material representation of fact upon which reliance is placed should the Department enter into the contract with the bidder. The Department may terminate the contract if it is later determined that the bidder rendered a false or erroneous assurance, and the surety providing the performance bond shall be responsible for the completion of the contract.

B. Felons

1. The Illinois Procurement Code provides:

Section 50-10. Felons. Unless otherwise provided, no person or business convicted of a felony shall do business with the State of Illinois or any state agency from the date of conviction until 5 years after the date of completion of the sentence for that felony, unless no person held responsible by a prosecutorial office for the facts upon which the conviction was based continues to have any involvement with the business.

2. The bidder assures the Department that the award and execution of the contract would not cause a violation of Section 50-10.

RETURN WITH BID

C. Conflicts of Interest

1. The Illinois Procurement Code provides in pertinent part:

Section 50-13. Conflicts of Interest.

(a) Prohibition. It is unlawful for any person holding an elective office in this State, holding a seat in the General Assembly, or appointed to or employed in any of the offices or agencies of state government and who receives compensation for such employment in excess of 60% of the salary of the Governor of the State of Illinois, or who is an officer or employee of the Capital Development Board or the Illinois Toll Highway Authority, or who is the spouse or minor child of any such person to have or acquire any contract, or any direct pecuniary interest in any contract therein, whether for stationery, printing, paper, or any services, materials, or supplies, that will be wholly or partially satisfied by the payment of funds appropriated by the General Assembly of the State of Illinois or in any contract of the Capital Development Board or the Illinois Toll Highway authority.

(b) Interests. It is unlawful for any firm, partnership, association or corporation, in which any person listed in subsection (a) is entitled to receive (i) more than 7 1/2% of the total distributable income or (ii) an amount in excess of the salary of the Governor, to have or acquire any such contract or direct pecuniary interest therein.

(c) Combined interests. It is unlawful for any firm, partnership, association, or corporation, in which any person listed in subsection (a) together with his or her spouse or minor children is entitled to receive (i) more than 15%, in the aggregate, of the total distributable income or (ii) an amount in excess of 2 times the salary of the Governor, to have or acquire any such contract or direct pecuniary interest therein.

(d) Securities. Nothing in this Section invalidates the provisions of any bond or other security previously offered or to be offered for sale or sold by or for the State of Illinois.

(e) Prior interests. This Section does not affect the validity of any contract made between the State and an officer or employee of the State or member of the General Assembly, his or her spouse, minor child or any combination of those persons if that contract was in existence before his or her election or employment as an officer, member, or employee. The contract is voidable, however, if it cannot be completed within 365 days after the officer, member, or employee takes office or is employed.

The current salary of the Governor is \$145,877.00. Sixty percent of the salary is \$87,526.20.

2. The bidder assures the Department that the award and execution of the contract would not cause a violation of Section 50-13, or that an effective exemption has been issued by the Board of Ethics to any individual subject to the Section 50-13 prohibitions pursuant to the provisions of Section 50-20 of the Code and Executive Order Number 3 (1998). Information concerning the exemption process is available from the Department upon request.

D. Negotiations

1. The Illinois Procurement Code provides in pertinent part:

Section 50-15. Negotiations.

(a) It is unlawful for any person employed in or on a continual contractual relationship with any of the offices or agencies of State government to participate in contract negotiations on behalf of that office or agency with any firm, partnership, association, or corporation with whom that person has a contract for future employment or is negotiating concerning possible future employment.

2. The bidder assures the Department that the award and execution of the contract would not cause a violation of Section 50-15, and that the bidder has no knowledge of any facts relevant to the kinds of acts prohibited therein.

RETURN WITH BID

E. Inducements

1. The Illinois Procurement Code provides:

Section 50-25. Inducement. Any person who offers or pays any money or other valuable thing to any person to induce him or her not to bid for a State contract or as recompense for not having bid on a State contract is guilty of a Class 4 felony. Any person who accepts any money or other valuable thing for not bidding for a State contract or who withholds a bid in consideration of the promise for the payment of money or other valuable thing is guilty of a Class 4 felony.

2. The bidder assures the Department that the award and execution of the contract would not cause a violation of Section 50-25, and that the bidder has no knowledge of any facts relevant to the kinds of acts prohibited therein.

F. Revolving Door Prohibition

1. The Illinois Procurement Code provides:

Section 50-30. Revolving door prohibition. Chief procurement officers, associate procurement officers, State purchasing officers, their designees whose principal duties are directly related to State procurement, and executive officers confirmed by the Senate are expressly prohibited for a period of 2 years after terminating an affected position from engaging in any procurement activity relating to the State agency most recently employing them in an affected position for a period of at least 6 months. The prohibition includes, but is not limited to: lobbying the procurement process; specifying; bidding; proposing bid, proposal, or contract documents; on their own behalf or on behalf of any firm, partnership, association, or corporation. This Section applies only to persons who terminate an affected position on or after January 15, 1999.

2. The bidder assures the Department that the award and execution of the contract would not cause a violation of Section 50-30, and that the bidder has no knowledge of any facts relevant to the kinds of acts prohibited therein.

G. Reporting Anticompetitive Practices

1. The Illinois Procurement Code provides:

Section 50-40. Reporting anticompetitive practices. When, for any reason, any vendor, bidder, contractor, chief procurement officer, State purchasing officer, designee, elected official, or State employee suspects collusion or other anticompetitive practice among any bidders, offers, contractors, proposers, or employees of the State, a notice of the relevant facts shall be transmitted to the Attorney General and the chief procurement officer.

2. The bidder assures the Department that it has not failed to report any relevant facts concerning the practices addressed in Section 50-40 which may involve the contract for which the bid is submitted.

H. Confidentiality

1. The Illinois Procurement Code provides:

Section 50-45. Confidentiality. Any chief procurement officer, State purchasing officer, designee, or executive officer who willfully uses or allows the use of specifications, competitive bid documents, proprietary competitive information, proposals, contracts, or selection information to compromise the fairness or integrity of the procurement, bidding, or contract process shall be subject to immediate dismissal, regardless of the Personnel code, any contract, or any collective bargaining agreement, and may in addition be subject to criminal prosecution.

2. The bidder assures the Department that it has no knowledge of any fact relevant to the practices addressed in Section 50-45 which may involve the contract for which the bid is submitted.

RETURN WITH BID

I. Insider Information

1. The Illinois Procurement Act provides:

Section 50-50. Insider information. It is unlawful for any current or former elected or appointed State official or State employee to knowingly use confidential information available only by virtue of that office or employment for actual or anticipated gain for themselves or another person.

2. The bidder assures the Department that it has no knowledge of any facts relevant to the practices addressed in Section 50-50 which may involve the contract for which the bid is submitted.

III. CERTIFICATIONS

A. The certifications hereinafter made by the bidder are each a material representation of fact upon which reliance is placed should the Department enter into the contract with the bidder. The Department may terminate the contract if it is later determined that the bidder rendered a false or erroneous certification, and the surety providing the performance bond shall be responsible for completion of the contract.

B. Bribery

1. The Illinois Procurement Code provides:

Section 50-5. Bribery.

(a) Prohibition. No person or business shall be awarded a contract or subcontract under this Code who:

(1) has been convicted under the laws of Illinois or any other state of bribery or attempting to bribe an officer or employee of the State of Illinois or any other state in that officer's or employee's official capacity; or

(2) has made an admission of guilt of that conduct that is a matter of record but has not been prosecuted for that conduct.

(b) Businesses. No business shall be barred from contracting with any unit of State or local government as a result of a conviction under this Section of any employee or agent of the business if the employee or agent is no longer employed by the business and:

(1) the business has been finally adjudicated not guilty; or

(2) the business demonstrates to the governmental entity with which it seeks to contract, and that entity finds that the commission of the offense was not authorized, requested, commanded, or performed by a director, officer, or high managerial agent on behalf of the business as provided in paragraph (2) of subsection (a) of Section 5-4 of the Criminal Code of 1961.

(c) Conduct on behalf of business. For purposes of this Section, when an official, agent, or employee of a business committed the bribery or attempted bribery on behalf of the business and in accordance with the direction or authorization of a responsible official of the business, the business shall be chargeable with the conduct.

(d) Certification. Every bid submitted to and contract executed by the State shall contain a certification by the contractor that the contractor is not barred from being awarded a contract or subcontract under this Section. A contractor who makes a false statement, material to the certification, commits a Class 3 felony.

2. The bidder certifies that it is not barred from being awarded a contract under Section 50.5.

RETURN WITH BID

C. Educational Loan

1. Section 3 of the Educational Loan Default Act provides:

§ 3. No State agency shall contract with an individual for goods or services if that individual is in default, as defined in Section 2 of this Act, on an educational loan. Any contract used by any State agency shall include a statement certifying that the individual is not in default on an educational loan as provided in this Section.

2. The bidder, if an individual as opposed to a corporation, partnership or other form of business organization, certifies that the bidder is not in default on an educational loan as provided in Section 3 of the Act.

D. Bid-Rigging/Bid Rotating

1. Section 33E-11 of the Criminal Code of 1961 provides:

§ 33E-11. (a) Every bid submitted to and public contract executed pursuant to such bid by the State or a unit of local government shall contain a certification by the prime contractor that the prime contractor is not barred from contracting with any unit of State or local government as a result of a violation of either Section 33E-3 or 33E-4 of this Article. The State and units of local government shall provide the appropriate forms for such certification.

(b) A contractor who makes a false statement, material to the certification, commits a Class 3 felony.

A violation of Section 33E-3 would be represented by a conviction of the crime of bid-rigging which, in addition to Class 3 felony sentencing, provides that any person convicted of this offense or any similar offense of any state or the United States which contains the same elements as this offense shall be barred for 5 years from the date of conviction from contracting with any unit of State or local government. No corporation shall be barred from contracting with any unit of State or local government as a result of a conviction under this Section of any employee or agent of such corporation if the employee so convicted is no longer employed by the corporation and: (1) it has been finally adjudicated not guilty or (2) if it demonstrates to the governmental entity with which it seeks to contract and that entity finds that the commission of the offense was neither authorized, requested, commanded, nor performed by a director, officer or a high managerial agent in behalf of the corporation.

A violation of Section 33E-4 would be represented by a conviction of the crime of bid-rotating which, in addition to Class 2 felony sentencing, provides that any person convicted of this offense or any similar offense of any state or the United States which contains the same elements as this offense shall be permanently barred from contracting with any unit of State or local government. No corporation shall be barred from contracting with any unit of State or local government as a result of a conviction under this Section of any employee or agent of such corporation if the employee so convicted is no longer employed by the corporation and: (1) it has been finally adjudicated not guilty or (2) if it demonstrates to the governmental entity with which it seeks to contract and that entity finds that the commission of the offense was neither authorized, requested, commanded, nor performed by a director, officer or a high managerial agent in behalf of the corporation.

2. The bidder certifies that it is not barred from contracting with the Department by reason of a violation of either Section 33E-3 or Section 33E-4.

E. International Anti-Boycott

1. Section 5 of the International Anti-Boycott Certification Act provides:

§ 5. State contracts. Every contract entered into by the State of Illinois for the manufacture, furnishing, or purchasing of supplies, material, or equipment or for the furnishing of work, labor, or services, in an amount exceeding the threshold for small purchases according to the purchasing laws of this State or \$10,000.00, whichever is less, shall contain certification, as a material condition of the contract, by which the contractor agrees that neither the contractor nor any substantially-owned affiliated company is participating or shall participate in an international boycott in violation of the provisions of the U.S. Export Administration Act of 1979 or the regulations of the U.S. Department of Commerce promulgated under that Act.

2. The bidder makes the certification set forth in Section 5 of the Act.

RETURN WITH BID

F. Drug Free Workplace

1. The Illinois “Drug Free Workplace Act” applies to this contract and it is necessary to comply with the provisions of the “Act” if the contractor is a corporation, partnership, or other entity (including a sole proprietorship) which has 25 or more employees.

2. The bidder certifies that if awarded a contract in excess of \$5,000 it will provide a drug free workplace by:

(a) Publishing a statement notifying employees that the unlawful manufacture, distribution, dispensation, possession or use of a controlled substance, including cannabis, is prohibited in the contractor’s workplace; specifying the actions that will be taken against employees for violations of such prohibition; and notifying the employee that, as a condition of employment on such contract, the employee shall abide by the terms of the statement, and notify the employer of any criminal drug statute conviction for a violation occurring in the workplace no later than five (5) days after such conviction.

(b) Establishing a drug free awareness program to inform employees about the dangers of drug abuse in the workplace; the contractor’s policy of maintaining a drug free workplace; any available drug counseling, rehabilitation, and employee assistance programs; and the penalties that may be imposed upon employees for drug violations.

(c) Providing a copy of the statement required by subparagraph (1) to each employee engaged in the performance of the contract and to post the statement in a prominent place in the workplace.

(d) Notifying the Department within ten (10) days after receiving notice from an employee or otherwise receiving actual notice of the conviction of an employee for a violation of any criminal drug statute occurring in the workplace.

(e) Imposing or requiring, within 30 days after receiving notice from an employee of a conviction or actual notice of such a conviction, an appropriate personnel action, up to and including termination, or the satisfactory participation in a drug abuse assistance or rehabilitation program approved by a federal, state or local health, law enforcement or other appropriate agency.

(f) Assisting employees in selecting a course of action in the event drug counseling, treatment, and rehabilitation is required and indicating that a trained referral team is in place.

(g) Making a good faith effort to continue to maintain a drug free workplace through implementation of the actions and efforts stated in this certification.

G. Debt Delinquency

1. The Illinois Procurement Code provides:

Section 50-11 and 50-12. Debt Delinquency.

The contractor or bidder certifies that it, or any affiliate, is not barred from being awarded a contract under 30 ILCS 500. Section 50-11 prohibits a person from entering into a contract with a State agency if it knows or should know that it, or any affiliate, is delinquent in the payment of any debt to the State as defined by the Debt Collection Board. Section 50-12 prohibits a person from entering into a contract with a State agency if it, or any affiliate, has failed to collect and remit Illinois Use Tax on all sales of tangible personal property into the State of Illinois in accordance with the provisions of the Illinois Use Tax Act. The contractor further acknowledges that the contracting State agency may declare the contract void if this certification is false or if the contractor, or any affiliate, is determined to be delinquent in the payment of any debt to the State during the term of the contract.

RETURN WITH BID

H. Sarbanes-Oxley Act of 2002

1. The Illinois Procurement Code provides:

Section 50-60(c).

The contractor certifies in accordance with 30 ILCS 500/50-10.5 that no officer, director, partner or other managerial agent of the contracting business has been convicted of a felony under the Sarbanes-Oxley Act of 2002 or a Class 3 or Class 2 felony under the Illinois Securities Law of 1953 for a period of five years prior to the date of the bid or contract. The contractor acknowledges that the contracting agency shall declare the contract void if this certification is false.

I. Section 42 of the Environmental Protection Act

The contractor certifies in accordance with 30 ILCS 500/50-12 that the bidder or contractor is not barred from being awarded a contract under this Section which prohibits the bidding on or entering into contracts with the State of Illinois or a State agency by a person or business found by a court or the Pollution Control Board to have committed a willful or knowing violation of Section 42 of the Environmental Protection Act for a period of five years from the date of the order. The contractor acknowledges that the contracting agency may declare the contract void if this certification is false.

RETURN WITH BID

IV. DISCLOSURES

A. The disclosures hereinafter made by the bidder are each a material representation of fact upon which reliance is placed should the Department enter into the contract with the bidder. The Department may terminate the contract if it is later determined that the bidder rendered a false or erroneous disclosure, and the surety providing the performance bond shall be responsible for completion of the contract.

B. Financial Interests and Conflicts of Interest

1. Section 50-35 of the Illinois Procurement Code provides that all bids of more than \$10,000 shall be accompanied by disclosure of the financial interests of the bidder. This disclosed information for the successful bidder, will be maintained as public information subject to release by request pursuant to the Freedom of Information Act.

The financial interests to be disclosed shall include ownership or distributive income share that is in excess of 5%, or an amount greater than 60% of the annual salary of the Governor, of the bidding entity or its parent entity, whichever is less, unless the contractor or bidder is a publicly traded entity subject to Federal 10K reporting, in which case it may submit its 10K disclosure in place of the prescribed disclosure. The disclosure shall include the names, addresses, and dollar or proportionate share of ownership of each person making the disclosure, their instrument of ownership or beneficial relationship, and notice of any potential conflict of interest resulting from the current ownership or beneficial interest of each person making the disclosure having any of the relationships identified in Section 50-35 and on the disclosure form.

In addition, all disclosures shall indicate any other current or pending contracts, proposals, leases, or other ongoing procurement relationships the bidding entity has with any other unit of state government and shall clearly identify the unit and the contract, proposal, lease, or other relationship.

2. Disclosure Forms. Disclosure Form A is attached for use concerning the individuals meeting the above ownership or distributive share requirements. Subject individuals should be covered each by one form. In addition, a second form (Disclosure Form B) provides for the disclosure of current or pending procurement relationships with other (non-IDOT) state agencies. **The forms must be included with each bid or incorporated by reference.**

C. Disclosure Form Instructions

Form A: For bidders that have previously submitted the information requested in Form A

The Department has retained the Form A disclosures submitted by all bidders responding to these requirements for the April 24, 1998 or any subsequent letting conducted by the Department. The bidder has the option of submitting the information again or the bidder may sign the following certification statement indicating that the information previously submitted by the bidder is, as of the date of signature, current and accurate. The Certification must be signed and dated by a person who is authorized to execute contracts for the bidding company. Before signing this certification, the bidder should carefully review its prior submissions to ensure the Certification is correct. If the Bidder signs the Certification, the Bidder should proceed to Form B instructions.

CERTIFICATION STATEMENT

I have determined that the Form A disclosure information previously submitted is current and accurate, and all forms are hereby incorporated by reference in this bid. Any necessary additional forms or amendments to previously submitted forms are attached to this bid.

(Bidding Company)

Name of Authorized Representative (type or print)

Title of Authorized Representative (type or print)

Signature of Authorized Representative

Date

Form A: For bidders who have NOT previously submitted the information requested in Form A

If the bidder is a publicly traded entity subject to Federal 10K reporting, the 10K Report may be submitted to meet the requirements of Form A. If a bidder is not subject to Federal 10K reporting, the bidder must determine if any individuals are required by law to complete a financial disclosure form. To do this, the bidder should answer each of the following questions. A "YES" answer indicates Form A must be completed. If the answer to each of the following questions is "NO", then the NOT APPLICABLE STATEMENT on the second page of Form A must be signed and dated by a person that is authorized to execute contracts for the bidding company. Note These questions are for assistance only and are not required to be completed.

1. Does anyone in your organization have a direct or beneficial ownership share of greater than 5% of the bidding entity or parent entity? YES _____ NO _____
2. Does anyone in your organization have a direct or beneficial ownership share of less than 5%, but which has a value greater than \$87,526.20? YES _____ NO _____
3. Does anyone in your organization receive more than \$87,526.20 of the bidding entity's or parent entity's distributive income? (Note: Distributive income is, for these purposes, any type of distribution of profits. An annual salary is not distributive income.) YES _____ NO _____
4. Does anyone in your organization receive greater than 5% of the bidding entity's or parent entity's total distributive income, but which is less than \$87,526.20? YES _____ NO _____

(Note: Only one set of forms needs to be completed per person per bid even if a specific individual would require a yes answer to more than one question.)

A "YES" answer to any of these questions requires the completion of Form A. The bidder must determine each individual in the bidding entity or the bidding entity's parent company that would cause the questions to be answered "Yes". Each form must be signed and dated by a person that is authorized to execute contracts for your organization. **Photocopied or stamped signatures are not acceptable.** The person signing can be, but does not have to be, the person for which the form is being completed. The bidder is responsible for the accuracy of any information provided.

If the answer to each of the above questions is "NO", then the NOT APPLICABLE STATEMENT on page 2 of Form A must be signed and dated by a person that is authorized to execute contracts for your company.

Form B: Identifying Other Contracts & Procurement Related Information Disclosure Form B must be completed for each bid submitted by the bidding entity. It must be signed by an individual who is authorized to execute contracts for the bidding entity. *Note: Signing the NOT APPLICABLE STATEMENT on Form A does not allow the bidder to ignore Form B. Form B must be completed, signed and dated or the bidder may be considered nonresponsive and the bid will not be accepted.*

The Bidder shall identify, by checking Yes or No on Form B, whether it has any pending contracts (including leases), bids, proposals, or other ongoing procurement relationship with any other (non-IDOT) State of Illinois agency. If "No" is checked, the bidder only needs to complete the signature box on the bottom of Form B. If "Yes" is checked, the bidder must do one of the following:

Option I: If the bidder did not submit an Affidavit of Availability to obtain authorization to bid, the bidder must list all non-IDOT State of Illinois agency pending contracts, leases, bids, proposals, and other ongoing procurement relationships. These items may be listed on Form B or on an attached sheet(s). Do not include IDOT contracts. Contracts with cities, counties, villages, etc. are not considered State of Illinois agency contracts and are not to be included. Contracts with other State of Illinois agencies such as the Department of Natural Resources or the Capital Development Board must be included. Bidders who submit Affidavits of Availability are suggested to use Option II.

Option II: If the bidder is required and has submitted an Affidavit of Availability in order to obtain authorization to bid, the bidder may write or type "See Affidavit of Availability" which indicates that the Affidavit of Availability is incorporated by reference and includes all non-IDOT State of Illinois agency pending contracts, leases, bids, proposals, and other ongoing procurement relationships. For any contracts that are not covered by the Affidavit of Availability, the bidder must identify them on Form B or on an attached sheet(s). These might be such things as leases.

D. Bidders Submitting More Than One Bid

Bidders submitting multiple bids may submit one set of forms consisting of all required Form A disclosures and one Form B for use with all bids. Please indicate in the space provided below the bid item that contains the original disclosure forms and the bid items which incorporate the forms by reference.

- The bid submitted for letting item _____ contains the Form A disclosures or Certification Statement and the Form B disclosures. The following letting items incorporate the said forms by reference:

**ILLINOIS DEPARTMENT
OF TRANSPORTATION**

**Form A
Financial Information &
Potential Conflicts of Interest
Disclosure**

Contractor Name		
Legal Address		
City, State, Zip		
Telephone Number		Fax Number (if available)

Disclosure of the information contained in this Form is required by the Section 50-35 of the Illinois Procurement Code (30 ILCS 500). Vendors desiring to enter into a contract with the State of Illinois must disclose the financial information and potential conflict of interest information as specified in this Disclosure Form. This information shall become part of the publicly available contract file. This Form A must be completed for bids in excess of \$10,000, and for all open-ended contracts. **A publicly traded company may submit a 10K disclosure in satisfaction of the requirements set forth in Form A. See Disclosure Form Instructions.**

DISCLOSURE OF FINANCIAL INFORMATION

1. Disclosure of Financial Information. The individual named below has an interest in the BIDDER (or its parent) in terms of ownership or distributive income share in excess of 5%, or an interest which has a value of more than \$87,526.20 (60% of the Governor’s salary as of 10/1/2000). **(Make copies of this form as necessary and attach a separate Disclosure Form A for each individual meeting these requirements)**

FOR INDIVIDUAL (type or print information)	
NAME:	_____
ADDRESS	_____
Type of ownership/distributable income share:	
stock _____	sole proprietorship _____
partnership _____	other: (explain on separate sheet): _____
% or \$ value of ownership/distributable income share: _____	

2. Disclosure of Potential Conflicts of Interest. Check “Yes” or “No” to indicate which, if any, of the following potential conflict of interest relationships apply. If the answer to any question is “Yes”, please attach additional pages and describe.

(a) State employment, currently or in the previous 3 years, including contractual employment of services.
Yes _____ No _____

(b) State employment of spouse, father, mother, son, or daughter, including contractual employment for services in the previous 2 years.
Yes _____ No _____

(c) Elective status; the holding of elective office of the State of Illinois, the government of the United States, any unit of local government authorized by the Constitution of the State of Illinois or the statutes of the State of Illinois currently or in the previous 3 years.
Yes _____ No _____

(d) Relationship to anyone holding elective office currently or in the previous 2 years; spouse, father, mother, son, or daughter
Yes _____ No _____

RETURN WITH BID/OFFER

(e) Appointive office; the holding of any appointive government office of the State of Illinois, the United States of America, or any unit of local government authorized by the Constitution of the State of Illinois or the statutes of the State of Illinois, which office entitles the holder to compensation in excess of the expenses incurred in the discharge of that office currently or in the previous 3 years.

Yes _____ No _____

(f) Relationship to anyone holding appointive office currently or in the previous 2 years; spouse, father, mother, son, or daughter.

Yes _____ No _____

(g) Employment, currently or in the previous 3 years, as or by any registered lobbyist of the State government.

Yes _____ No _____

(h) Relationship to anyone who is or was a registered lobbyist in the previous 2 years; spouse, father, mother, son, or daughter.

Yes _____ No _____

(i) Compensated employment, currently or in the previous 3 years, by any registered election or reelection committee registered with the Secretary of State or any county clerk of the State of Illinois, or any political action committee registered with either the Secretary of State or the Federal Board of Elections.

Yes _____ No _____

(j) Relationship to anyone; spouse, father, mother, son, or daughter; who was a compensated employee in the last 2 years by any registered election or re-election committee registered with the Secretary of State or any county clerk of the State of Illinois, or any political action committee registered with either the Secretary of State or the Federal Board of Elections.

Yes _____ No _____

APPLICABLE STATEMENT

This Disclosure Form A is submitted on behalf of the INDIVIDUAL named on previous page.

Completed by:

Name of Authorized Representative (type or print)

Completed by:

Title of Authorized Representative (type or print)

Completed by:

_____ Date
Signature of Individual or Authorized Representative

NOT APPLICABLE STATEMENT

I have determined that no individuals associated with this organization meet the criteria that would require the completion of this Form A.

This Disclosure Form A is submitted on behalf of the CONTRACTOR listed on the previous page.

Name of Authorized Representative (type or print)

Title of Authorized Representative (type or print)

_____ Date
Signature of Authorized Representative

**ILLINOIS DEPARTMENT
OF TRANSPORTATION**

**Form B
Other Contracts &
Procurement Related Information
Disclosure**

Contractor Name		
Legal Address		
City, State, Zip		
Telephone Number		Fax Number (if available)

Disclosure of the information contained in this Form is required by the Section 50-35 of the Illinois Procurement Act (30 ILCS 500). This information shall become part of the publicly available contract file. This Form B must be completed for bids in excess of \$10,000, and for all open-ended contracts.

DISCLOSURE OF OTHER CONTRACTS AND PROCUREMENT RELATED INFORMATION

1. Identifying Other Contracts & Procurement Related Information. The BIDDER shall identify whether it has any pending contracts (including leases), bids, proposals, or other ongoing procurement relationship with any other State of Illinois agency: Yes _____ No _____

If **“No”** is checked, the bidder only needs to complete the signature box on the bottom of this page.

2. If “Yes” is checked. Identify each such relationship by showing State of Illinois agency name and other descriptive information such as bid or project number (attach additional pages as necessary). SEE DISCLOSURE FORM INSTRUCTIONS:

THE FOLLOWING STATEMENT MUST BE SIGNED

Name of Authorized Representative (type or print)	

Title of Authorized Representative (type or print)	
_____	_____
Signature of Authorized Representative	Date

RETURN WITH BID

SPECIAL NOTICE TO CONTRACTORS

The following requirements of the Illinois Department of Human Rights' Rules and Regulations are applicable to bidders on all construction contracts advertised by the Illinois Department of Transportation:

CONSTRUCTION EMPLOYEE UTILIZATION PROJECTION

- (a) All bidders on construction contracts shall complete and submit, along with and as part of their bids, a Bidder's Employee Utilization Form (Form BC-1256) setting forth a projection and breakdown of the total workforce intended to be hired and/or allocated to such contract work by the bidder including a projection of minority and female employee utilization in all job classifications on the contract project.
- (b) The Department of Transportation shall review the Employee Utilization Form, and workforce projections contained therein, of the contract awardee to determine if such projections reflect an underutilization of minority persons and/or women in any job classification in accordance with the Equal Employment Opportunity Clause and Section 7.2 of the Illinois Department of Human Rights' Rules and Regulations for Public Contracts adopted as amended on September 17, 1980. If it is determined that the contract awardee's projections reflect an underutilization of minority persons and/or women in any job classification, it shall be advised in writing of the manner in which it is underutilizing and such awardee shall be considered to be in breach of the contract unless, prior to commencement of work on the contract project, it submits revised satisfactory projections or an acceptable written affirmative action plan to correct such underutilization including a specific timetable geared to the completion stages of the contract.
- (c) The Department of Transportation shall provide to the Department of Human Rights a copy of the contract awardee's Employee Utilization Form, a copy of any required written affirmative action plan, and any written correspondence related thereto. The Department of Human Rights may review and revise any action taken by the Department of Transportation with respect to these requirements.

RETURN WITH BID

PART II. WORKFORCE PROJECTION - continued

- B. Included in "Total Employees" under Table A is the total number of **new hires** that would be employed in the event the undersigned bidder is awarded this contract.

The undersigned bidder projects that: (number) _____ new hires would be recruited from the area in which the contract project is located; and/or (number) _____ new hires would be recruited from the area in which the bidder's principal office or base of operation is located.

- C. Included in "Total Employees" under Table A is a projection of numbers of persons to be employed directly by the undersigned bidder as well as a projection of numbers of persons to be employed by subcontractors.

The undersigned bidder estimates that (number) _____ persons will be directly employed by the prime contractor and that (number) _____ persons will be employed by subcontractors.

PART III. AFFIRMATIVE ACTION PLAN

- A. The undersigned bidder understands and agrees that in the event the foregoing minority and female employee utilization projection included under **PART II** is determined to be an underutilization of minority persons or women in any job category, and in the event that the undersigned bidder is awarded this contract, he/she will, prior to commencement of work, develop and submit a written Affirmative Action Plan including a specific timetable (geared to the completion stages of the contract) whereby deficiencies in minority and/or female employee utilization are corrected. Such Affirmative Action Plan will be subject to approval by the contracting agency and the **Department of Human Rights**.
- B. The undersigned bidder understands and agrees that the minority and female employee utilization projection submitted herein, and the goals and timetable included under an Affirmative Action Plan if required, are deemed to be part of the contract specifications.

Company _____ Telephone Number _____

 Address _____

NOTICE REGARDING SIGNATURE

The Bidder's signature on the Proposal Signature Sheet will constitute the signing of this form. The following signature block needs to be completed only if revisions are required.

Signature: _____ Title: _____ Date: _____

- Instructions: All tables must include subcontractor personnel in addition to prime contractor personnel.
- Table A - Include both the number of employees that would be hired to perform the contract work and the total number currently employed (Table B) that will be allocated to contract work, and include all apprentices and on-the-job trainees. The "Total Employees" column should include all employees including all minorities, apprentices and on-the-job trainees to be employed on the contract work.
 - Table B - Include all employees currently employed that will be allocated to the contract work including any apprentices and on-the-job trainees currently employed.
 - Table C - Indicate the racial breakdown of the total apprentices and on-the-job trainees shown in Table A.

RETURN WITH BID

CERTIFICATIONS REQUIRED BY STATE AND/OR FEDERAL LAW. The bidder is required by State and/or Federal law to make the below certifications and assurances as a part of the proposal and contract upon award. It is understood by the bidder that the certifications and assurances made herein are a part of the contract.

By signing the Proposal Signature Sheet, the bidder certifies that he/she has read and completed each of the following certifications and assurances, that required responses are true and correct and that the certified signature of the Proposal Signature Sheet constitutes an endorsement and execution of each certification and assurance as though each was individually signed:

A. By the execution of this proposal, the signing bidder certifies that the bidding entity has not, either directly or indirectly, entered into any agreement, participated in any collusion, or otherwise taken any action, in restraint of free competitive bidding in connection with the submitted bid. This statement made by the undersigned bidder is true and correct under penalty of perjury under the laws of the United States.

B. **CERTIFICATION, EQUAL EMPLOYMENT OPPORTUNITY:**

1. Have you participated in any previous contracts or subcontracts subject to the equal opportunity clause.
YES _____ NO _____

2. If answer to #1 is yes, have you filed with the Joint Reporting Committee, the Director of OFCC, any Federal agency, or the former President's Committee on Equal Employment Opportunity, all reports due under the applicable filing requirements of those organizations? YES _____ NO _____

C. **BUY AMERICAN - STEEL AND MANUFACTURED PRODUCTS FOR CONSTRUCTION CONTRACTS (JAN 1991)**

(a) The Aviation Safety and Capacity Expansion Act of 1990 provides that preference be given to steel and manufactured products produced in the United States when funds are expended pursuant to a grant issued under the Airport Improvement Program. The following terms apply:

1. Steel and manufactured products. As used in this clause, steel and manufactured products include (1) steel produced in the United States or (2) a manufactured product produced in the United States, if the cost of its components mined, produced or manufactured in the United States exceeds 60 percent of the cost of all its components and final assembly has taken place in the United States. Components of foreign origin of the same class or kind as the products referred to in subparagraphs (b)(1) or (2) shall be treated as domestic.

2. Components. As used in this clause, components means those articles, materials, and supplies incorporated directly into steel and manufactured products.

3. Cost of Components. This means the costs for production of the components, exclusive of final assembly labor costs.

(b) The successful bidder will be required to assure that only domestic steel and manufactured products will be used by the Contractor, subcontractors, materialmen, and suppliers in the performance of this contract, except those-

- (1) that the U.S. Department of Transportation has determined, under the Aviation Safety and Capacity Expansion Act of 1990, are not produced in the United States in sufficient and reasonably available quantities of a satisfactory quality;

- (2) that the U.S. Department of Transportation has determined, under the Aviation Safety and Capacity Expansion Act of 1990, that domestic preference would be inconsistent with the public interest; or

- (3) that inclusion of domestic material will increase the cost of the overall project contract by more than 25 percent.

(End of Clause)

RETURN WITH BID

D. BUY AMERICAN CERTIFICATE (JAN 1991)

By submitting a bid/proposal under this solicitation, except for those items listed by the offeror below or on a separate and clearly identified attachment to this bid/proposal, the offeror certifies that steel and each manufactured product, is produced in the United States (as defined in the clause Buy American - Steel and Manufactured Products or Buy American - Steel and Manufactured Products For Construction Contracts) and that components of unknown origin are considered to have been produced or manufactured outside the United States.

Offerors may obtain from (IDOT, Division of Aeronautics) lists of articles, materials, and supplies excepted from this provision.

PRODUCT

COUNTRY OF ORIGIN

E. NPDES CERTIFICATION

In accordance with the provisions of the Illinois Environmental Protection Act, the Illinois Pollution Control Board Rules and Regulations (35 Ill. Adm. Code, Subtitle C, Chapter I), and the Clean Water Act, and the regulations thereunder, this certification is required for all construction contracts that will result in the disturbance of five or more acres total land area.

The undersigned bidder certifies under penalty of law that he/she understands the terms and conditions of the general National Pollutant Discharge Elimination System (NPDES) permit (ILR100000) that authorizes the storm water discharges associated with industrial activity from the construction site identified as part of this certification.

The Airport Owner or its Agent will:

- 1) prepare, sign and submit the Notice of Intent (NOI)
- 2) conduct site inspections and complete and file the inspection reports
- 3) submit Incidence of Non-Compliance (ION) forms
- 4) submit Notice of Termination (NOT) form

Prior to the issuance of the Notice-to-Proceed, for each erosion control measure identified in the Storm Water Pollution Prevention Plan, the contractor or subcontractor responsible for the control measure(s) must sign the above certification (forms to be provided by the Department).

F. NON-APPROPRIATION CLAUSE

By submitting a bid/proposal under this solicitation the offeror certifies that he/she understands that obligations of the State will cease immediately without penalty or further payment being required in any fiscal year the Illinois General Assembly fails to appropriate or otherwise make available sufficient funds for this contract.

G. Contractor is not delinquent in the payment of any debt to the State (or if delinquent has entered into a deferred payment plan to pay the debt), and Contractor acknowledges the contracting state agency may declare the contract void if this certification is false (30 ILCS 500/50-11, effective July 1, 2002).

RETURN WITH BID

NOTICE TO BIDDERS

1. **TIME AND PLACE OF OPENING BIDS.** Sealed proposals for the improvement described herein will be received by the Department of Transportation at the Harry R. Hanley Building, 2300 South Dirksen Parkway in Springfield, Illinois until 10:00 o'clock a.m., April 28, 2006. All bids will be gathered, sorted, publicly opened and read in the auditorium at the Department of Transportation's Harry R. Hanley Building shortly after the 10:00 a.m. cut off time.
2. **DESCRIPTION OF WORK.** The proposed improvement, shown in detail on the plans issued by the Department includes, in general, the following described work:

Construct Runway 33 instrument landing system; Relocate Runway 9 localizer.
3. **INSTRUCTIONS TO BIDDERS.** (a) This Notice, the invitation for bids, proposal and award shall, together with all other documents in accordance with Article 10-15 of the Illinois Standard Specifications for Construction of Airports, become part of the contract. Bidders are cautioned to read and examine carefully all documents, to make all required inspections, and to inquire or seek explanation of the same prior to submission of a bid.

(b) State law, and, if the work is to be paid wholly or in part with Federal-aid funds, Federal law requires the bidder to make various certifications as a part of the proposal and contract. By execution and submission of the proposal, the bidder makes the certification contained therein. A false or fraudulent certification shall, in addition to all other remedies provided by law, be a breach of contract and may result in termination of the contract.
4. **AWARD CRITERIA AND REJECTION OF BIDS.** This contract will be awarded to the lowest responsive and responsible bidder considering conformity with the terms and conditions established by the Department in the proposal and contract documents. The issuance of plans and proposal forms for bidding based upon a prequalification rating shall not be the sole determinant of responsibility. The Department reserves the right to determine responsibility at the time of award, to reject any or all proposals, to readvertise the proposed improvement, and to waive technicalities.
5. **PRE-BID CONFERENCE.** There will be a pre-bid conference held at N/A at the Aurora Municipal Airport administration building. For engineering information, contact Craig Loudon of Crawford, Murphy & Tilly, Inc. at (630) 820-1022.
6. **DISADVANTAGED BUSINESS POLICY.** The DBE goal for this contract is 18.0%.
7. **SPECIFICATIONS AND DRAWINGS.** The work shall be done in accordance with the Illinois Standard Specifications for Construction of Airports, the Illinois Division of Aeronautics Supplemental Specifications and Recurring Special Provisions, the Special Provisions dated March 3, 2006 and the Construction Plans dated March 3, 2006 as approved by the Department of Transportation, Division of Aeronautics.

RETURN WITH BID

- 8. INSPECTION OF RECORDS.** The Contractor shall maintain an acceptable cost accounting system. The Sponsor, the FAA, and the Comptroller General of the United States shall have access to any books, documents, paper, and records of the Contractor which are directly pertinent to the specific contract for the purposes of making an audit, examination, excerpts, and transcriptions. The Contractor shall maintain all required records for three years after the Sponsor makes final payment and all other pending matters are closed.
- 9. RIGHTS TO INVENTIONS.** All rights to inventions and materials generated under this contract are subject to Illinois law and to regulations issued by the FAA and the Sponsor of the Federal grant under which this contract is executed. Information regarding these rights is available from the FAA and the Sponsor.
- 10. TERMINATION OF CONTRACT.**
1. The Sponsor may, by written notice, terminate this contract in whole or in part at any time, either for the Sponsor's convenience or because of failure to fulfill the contract obligations. Upon receipt of such notice services shall be immediately discontinued (unless the notice directs otherwise) and all materials as may have been accumulated in performing this contract, whether completed or in progress, delivered to the Sponsor.
 2. If the termination is for the convenience of the Sponsor, an equitable adjustment in the contract price shall be made, but no amount shall be allowed for anticipated profit on unperformed services.
 3. If the termination is due to failure to fulfill the Contractor's obligations, the Sponsor may take over the work and prosecute the same to completion by contract or otherwise. In such case, the Contractor shall be liable to the Sponsor for any additional cost occasioned to the Sponsor thereby.
 4. If, after notice of termination for failure to fulfill contract obligations, it is determined that the Contractor had not so failed, the termination shall be deemed to have been effected for the convenience of the Sponsor. In such event, adjustment in the contract price shall be made as provided in paragraph 2 of this clause.
 5. The rights and remedies of the sponsor provided in this clause are in addition to any other rights and remedies provided by law or under this contract.

RETURN WITH BID

11. BIDDING REQUIREMENTS AND BASIS OF AWARD. When alternates are included in the proposal, the following shall apply:

a. Additive Alternates

- (1) Bidders must submit a bid for the Base Bid and for all Additive Alternates.
- (2) Award of this contract will be made to the lowest responsible qualified bidder computed as follows:

The lowest aggregate amount of (i) the Base Bid plus (ii) any Additive Alternate(s) which the Department elects to award.

The Department may elect not to award any Additive Alternates. In that case, award will be to the lowest responsible qualified bidder of the Base Bid.

b. Optional Alternates

- (1) Bidders must submit a bid for the Base Bid and for either Alternate A or Alternate B or for both Alternate A and Alternate B.
- (2) Award of this contract will be made to the lowest responsible qualified bidder computed as follows:

The lower of the aggregate of either (i) the Base Bid plus Alternate A or (ii) the Base Bid plus Alternate B.

12. CONTRACT TIME. The Contractor shall complete all work within the specified contract time. Any calendar day extension beyond the specified contract time must be fully justified, requested by the Contractor in writing, and approved by the Engineer, or be subject to liquidated damages.

The contract time for this contract is 107 calendar days and is based on anticipated notice-to-proceed date of June 9, 2006.

13. INDEPENDENT WEIGHT CHECKS. The Department reserves the right to conduct random unannounced independent weight checks on any delivery for bituminous, aggregate or other pay item for which the method of measurement for payment is based on weight. The weight checks will be accomplished by selecting, at random, a loaded truck and obtaining a loaded and empty weight on an independent scale. In addition, the department may perform random weight checks by obtaining loaded and empty truck weights on portable scales operated by department personnel.

14. GOOD FAITH COMPLIANCE. The Illinois Department of Transportation has made a good faith effort to include all statements, requirements, and other language required by federal and state law and by various offices within federal and state governments whether that language is required by law or not. If anything of this nature has been left out or if additional language etc. is later required, the bidder/contractor shall cooperate fully with the Department to modify the contract or bid documents to correct the deficiency. If the change results in increased operational costs, the Department shall reimburse the contractor for such costs as it may find to be reasonable.

RETURN WITH BID

PROPOSAL SIGNATURE SHEET

The undersigned bidder hereby makes and submits this bid on the subject Proposal, thereby assuring the Department that all requirements of the Invitation for Bids and rules of the Department have been met, that there is no misunderstanding of the requirements of paragraph 4 of this Proposal, and that the contract will be executed in accordance with the rules of the Department if an award is made on this bid.

Firm Name _____

(IF AN INDIVIDUAL)

Signature of Owner _____

Business Address _____

Firm Name _____

By _____

(IF A CO-PARTNERSHIP)

Business Address _____

Name and Address of All Members of the Firm:

Corporate Name _____

Corporate Seal

By _____

President

(IF A CORPORATION)

Attest _____

Corporate Secretary

Business Address _____

Name of Corporate Officers:

President Corporate Secretary Treasurer

NOTARY CERTIFICATION

STATE OF ILLINOIS,

ALL SIGNATURES MUST BE NOTARIZED

COUNTY OF _____

I, _____, a Notary Public in and for said county, do hereby certify that _____

_____ AND _____

(Insert names of individual(s) signing on behalf of bidder)

who are each personally known to me to be the same persons whose names are subscribed to the foregoing instrument on behalf of the bidder, appeared before me this day in person and acknowledged that they signed, sealed, and delivered said instrument as their free and voluntary act for the uses and purposes therein set forth.

Given under my hand and notarial seal this _____ day of _____, A.D. _____

My commission expires _____ (Seal)

Notary Public



Return with Bid

Division of Aeronautics
Proposal Bid Bond
(Effective January 1, 2002)

Item No. 3A
Letting Date: April 28, 2006

Airport: Aurora Municipal Airport
Ill. Proj. No. ARR-3468
Fed. Proj. No. 3-17-0003-B31

KNOW ALL MEN BY THESE PRESENTS. that we, _____, as PRINCIPAL, and _____, as SURETY are held and firmly bound unto the, hereinafter called the SPONSOR, in the penal sum of 5 percent of the total bid price or of the amount specified in Section 6, PROPOSAL GUARANTEE of the Proposal Document, whichever is the lesser sum, well and truly to be paid unto the said SPONSOR, for the payment of which we bind ourselves, our heirs, executors, administrators, successors, and assigns.

THE CONDITION OF THIS OBLIGATION IS SUCH, that whereas the PRINCIPAL has submitted a Bid Proposal to the SPONSOR through its AGENT, the State of Illinois, Department of Transportation, Division of Aeronautics, for the improvement designated by the Transportation Bulletin Item Number and Letting Date indicated above;

NOW, THEREFORE, if the SPONSOR through its AGENT shall accept the Bid Proposal of the PRINCIPAL; and if PRINCIPAL shall within the time and as specified in the Bidding and Contract Documents, submit the DBE Utilization Plan that is acceptable and approved by the AGENT, and if after the award, the PRINCIPAL shall enter into a contract in accordance with the terms of the Bidding and Contract Documents including evidence of insurance coverage's and providing such bond as specified with good and sufficient surety for the faithful performance of such contract and for prompt payment of labor and material furnished in the prosecution thereof; or if, in the event of the failure of the PRINCIPAL to make the required DBE submission or to enter into such contract and to give the specified bond, the PRINCIPAL pays to the SPONSOR the difference not to exceed the penalty hereof between the amount in the Bid Proposal and such larger amount for which the SPONSOR may contract with another party to perform the work covered by said Proposal Document, then, this obligation to be void; otherwise to remain in full force and effect.

IN THE EVENT the SPONSOR acting through its AGENT determines the PRINCIPAL has failed to comply with any requirement as set forth in the preceding paragraph, then the SURETY shall pay the penal sum to the SPONSOR within fifteen (15) days of written demand therefor. If the SURETY does not make full payment within such period of time, the AGENT may bring an action to collect the amount owed. The SURETY is liable to the SPONSOR and to the AGENT for all its expenses, including attorney's fees, incurred in any litigation in which SPONSOR or AGENT prevail either in whole or in part.

IN WITNESS WHEREOF, the said PRINCIPAL and the said SURETY have caused this instrument to be signed by

their respective officers this _____ day of _____ A.D., 20 ____.

PRINCIPAL

SURETY

(Company Name)

(Company Name)

By: _____ (Signature & Title)

By: _____ (Signature of Attorney-in-Fact)

Notary Certification for Principal and Surety

State of Illinois)
County of _____) ss:

I, _____, a Notary Public in and for said County, do hereby certify that _____ and _____ (Insert names of individuals signing on behalf of PRINCIPAL & SURETY)

who are each personally known to me to be the same persons whose names are subscribed to the foregoing instrument on behalf of PRINCIPAL and SURETY, appeared before me this day in person and acknowledged respectively, that they signed and delivered said instrument as their free and voluntary act for uses and purposes therein set forth.

Given under my hand and notary seal this _____ day of _____ A.D., 20 ____

My commission expires _____ (Notary Public)

In lieu of completing the above section of the Proposal Bid Form, the PRINCIPAL may file an Electronic Bid Bond. By signing below, the PRINCIPAL is ensuring the identified electronic bid bond has been executed and the PRINCIPAL and SURETY are firmly bound to the SPONSOR through its AGENT under the conditions of the Bid Bond as shown above.

Electronic Bid Bond ID#

Company/Bidder Name

Signature and Title
Form D.E. (Rev. 12-2001)



PROPOSALS

for construction work advertised for bids by the
Illinois Department of Transportation

Item No.	Item No.	Item No.

Submitted By:

Name:
Address:
Phone No.

Bidders should affix this form to the front of a 10" x 13" envelope and use that envelope for the submittal of bids. If proposals are mailed, they should be enclosed in a second or outer envelope addressed to:

Engineer of Design and Environment - Room 323
Illinois Department of Transportation
2300 South Dirksen Parkway
Springfield, Illinois 62764

CONTRACTOR OFFICE COPY OF CONTRACT SPECIFICATIONS

NOTICE

None of the following material needs to be returned with the bid package unless the special provisions require documentation and/or other information to be submitted.



Illinois Department of Transportation

CONTRACT REQUIREMENTS

(1) Airport Improvement Program projects. The work in this contract is included in the federal Airport Improvement Program and is being undertaken and accomplished by the Illinois Department of Transportation, Division of Aeronautics and the Municipality, hereinafter called the Co-Sponsors, in accordance with the terms and conditions of a Grant Agreement between the Co-Sponsors and the United States, under the Airport and Airway Improvement Act of 1982 (Public Law 97-248; Title V, Section 501 et seq., September 3, 1982; 96 Stat. 671; codified at 49 U.S.C Section 2201 et seq.) and Part 152 of the Federal Aviation Regulations (14 CFR Part 152), pursuant to which the United States has agreed to pay a certain percentage of the costs of the Project that are determined to be allowable Project costs under the Act. The United States is not a party to this contract and no reference in this contract to FAA or representative thereof, or to any rights granted to the FAA or any representative thereof, or the United States, by the contract, makes the United States a party to this contract.

(2) Consent of Assignment. The Contractor shall obtain the prior written consent of the Co-Sponsors to any proposed assignment of any interest in or part of this contract.

(3) Convict Labor. No convict labor may be employed under this contract.

(4) Veterans Preference. In the employment of labor, except in executive, administrative, and supervisory positions, preference shall be given to veterans of the Vietnam era and disabled veterans as defined in Section 515(c) of the Airport and Airway Improvement Act of 1982. However, this preference shall apply only where the individuals are available and qualified to perform the work to which the employment relates.

(5) Withholding: Sponsor from Contractor. Whether or not payments or advances to the Co-Sponsors are withheld or suspended by the FAA, the Co-Sponsors may withhold or cause to be withheld from the Contractor so much of the accrued payments or advances as may be considered necessary to pay laborers and mechanics employed by the Contractor or any subcontractor on the work the full amount of wages required by this contract.

(6) Nonpayment of Wages. If the Contractor or subcontractor fails to pay any laborer or mechanic employed or working on the site of the work any of the wages required by this contract the Co-Sponsors may, after written notice to the Contractor, take such action as may be necessary to cause the suspension of any further payment or advance of funds until the violations cease.

(7) FAA Inspection and Review. The Contractor shall allow any authorized representative of the FAA to inspect and review any work or materials used in the performance of this contract.

(8) Subcontracts. The Contractor shall insert in each of his subcontracts the provisions contained in Paragraphs (1), (3), (4), (5), (6), and (7) above and also a clause requiring the subcontractors to include these provisions in any lower tier subcontracts which they may enter into, together with a clause requiring this insertion in any further subcontracts that may in turn be made.

(9) Contract Termination. A breach of Paragraph (6), (7), and (8) above may be grounds for termination of the contract.

PROVISIONS REQUIRED BY THE REGULATIONS OF THE SECRETARY OF LABOR 29 CFR 5.5

(a) Contract Provisions and Related Matters.

(1) Minimum Wages.

Revised 1/92

(i) All laborers and mechanics employed or working upon the site of the work will be paid unconditionally and not less often than once a week, and without subsequent deduction or rebate on any account (except such payroll deductions as are permitted by regulations issued by the Secretary of Labor under the Copeland Act (29 CFR Part 3)), the full amount of wages and bona fide fringe benefits (or cash equivalents thereof) due at time of payment computed at rates not less than those contained in the wage determination of the Secretary of Labor which is attached hereto and made a part hereof, regardless of any contractual relationship which may be alleged to exist between the Contractor and such laborers and mechanics. Contributions made or costs reasonably anticipated for bona fide fringe benefits under section 1(b)(2) of the Davis-Bacon Act on behalf of laborers or mechanics are considered wages paid to such laborers or mechanics, subject to the provision of paragraph (a)(1)(iv) of this section; also, regular contributions made or costs incurred for more than a weekly period (but not less often than quarterly) under plans, funds, or programs which cover the particular weekly period, are deemed to be constructively made or incurred during such weekly period. Such laborers and mechanics shall be paid the appropriate wage rate and fringe benefits on the wage determination for the classification of work actually performed, without regard to skill, except as provided in paragraph 5.5(a)(4). Laborers or mechanics performing work in more than one classification may be compensated at the rate specified for each classification for the time actually worked therein: provided, that the employer's payroll records accurately set forth the time spent in each classification in which work is performed. The wage determination (including any additional classification and wage rates conformed under paragraph (a)(1)(ii) of this section) and the Davis-Bacon poster (WH-1321) shall be posted at all times by the Contractor and its subcontractors at the site of the work in a prominent and accessible place where it can be easily seen by the workers.

(ii)(A) The contracting officer shall require that any class of laborers or mechanics which is not listed in the wage determination and which is to be employed under the contract shall be classified in conformance with the wage determination. The contracting officer shall approve an additional classification and wage rate and fringe benefits therefor only when the following criteria have been met:

- (1) The work to be performed by the classification requested is not performed by a classification in the wage determination; and
- (2) The classification is utilized in the area by the construction industry; and
- (3) The proposed wage rate, including any bona fide fringe benefits, bears a reasonable relationship to the wage rates contained in the wage determination.

(ii)(B) If the Contractor and the laborers and mechanics to be employed in the classification (if known), or their representatives, and the contracting officer agree on the classification and wage rate (including the amount designated for fringe benefits where appropriate), a report of the action taken shall be sent by the contracting officer to the Administrator of the Wage and Hour Division, Employment Standards Administration, U.S. Department of Labor, Washington, D.C. 20210. The Administrator, or an authorized representative, will approve, modify, or disapprove every additional classification action within 30 days of receipt and so advise the contracting officer or will notify the contracting officer within the 30-day period that additional time is necessary. (Approved by the Office of Management and Budget under OMB control number 1215-0140).

(ii)(C) In the event the Contractor, the laborers or mechanics to be employed in the classification or their representatives, and the contracting officer do not agree on the proposed classification and wage rate (including the amount designated for fringe benefits, where appropriate), the contracting officer shall refer the questions, including the views of all interested parties and the recommendation of the contracting officer, to the Administrator for determination. The Administrator, or an authorized representative, will issue a determination within 30 days of receipt and so advise the contracting officer or will notify the contracting officer within the 30-day period that additional time is necessary. (Approved by the Office of Management and Budget under OMB control number 1215-0140).

(ii)(D) The wage rate (including fringe benefits where appropriate) determined pursuant to subparagraphs (1)(B) or (C) of this paragraph, shall be paid to all workers performing work in the classification under this contract from the first day on which work is performed in the classification.

(iii) Whenever the minimum wage rate prescribed in the contract for a class of laborers or mechanics includes a fringe benefit which is not expressed as an hourly rate, the Contractor shall either pay the benefit as stated in the wage determination or shall pay another bona fide fringe benefit or an hourly cash equivalent thereof.

(iv) If the Contractor does not make payments to a trustee or other third person, the Contractor may consider as part of the wages of any laborer or mechanic the amount of any costs reasonably anticipated in providing bona fide fringe benefits under a plan or program, provided, that the Secretary of Labor has found, upon the written request of the Contractor, that the applicable standards of the Davis-Bacon Act have been met. The Secretary of Labor may require the Contractor to set aside in a separate account assets for the meeting of obligations under the plan or program. (Approved by the Office of Management and Budget under OMB control number 1215-0140).

(2) Withholding. The Federal Aviation Administration shall upon its own action or written request of an authorized representative of the Department of Labor withhold or cause to be withheld from the Contractor under this contract or any other Federal contract with the same prime Contractor, or any other Federally-assisted contract subject to Davis-Bacon prevailing wage requirements, which is held by the same prime Contractor, so much of the accrued payments or advances as may be considered necessary to pay laborers and mechanics, including apprentices, trainees, and helpers, employed by the Contractor or any subcontractor the full amount of wages required by the contract. In the event of failure to pay any laborer or mechanic, including any apprentice, trainee, or helper, employed or working on the site of the work, all or part of the wages required by the contract, the (Agency) may, after written notice to the Contractor, sponsor, applicant, or owner, take such action as may be necessary to cause the suspension of any further payment, advance, or guarantee of funds until such violations have ceased.

(3) Payrolls and basic records.

(i) Payrolls and basic records relating thereto shall be maintained by the Contractor during the course of the work and preserved for a period of three years thereafter for all laborers and mechanics working at the site of the work. Such records shall contain the name, address, and social security number of each such work, his or her correct classification, hourly rates of wages paid (including rates of contributions or costs anticipated for bona fide fringe benefits or cash equivalents thereof of the types described in section 1(b)(2)(B) of the Davis-Bacon Act), daily and weekly number of hours worked, deductions made and actual wages paid. Whenever the Secretary of Labor has found under 29 CFR 5.5(a)(1)(iv) that the wages of any laborer or mechanic include the amount of any costs reasonably anticipated in providing benefits under a plan or program described in section 1(b)(2)(B) of the Davis-Bacon Act, the Contractor shall maintain records which show that the commitment to provide such benefits is enforceable, that the plan or program is financially responsible, and that the plan or program has been communicated in writing to the laborers or mechanics affected, and records which show the costs anticipated or the actual cost incurred in providing such benefits. Contractors employing apprentices or trainees under approved programs shall maintain written evidence of the registration of apprenticeship programs and certification of trainee programs, the registration of the apprentices and trainees, and the ratios and wage rates prescribed in the applicable programs. (Approved by the Office Management and Budget under OMB control numbers 1215-0140 and 1215-0017).

(ii)(A) The Contractor shall submit weekly for each week in which any contract work is performed a copy of all payrolls to the Federal Aviation Administration if the agency is a party to the contract, but if the agency is not such a party, the Contractor will submit the payrolls to the applicant, sponsor, or owner, as the case may be, for transmission to the Federal Aviation Administration. The payrolls submitted shall set out accurately and completely all of the information required to be maintained under paragraph 5.5(a)(3)(i) of Regulations, 29 CFR Part 5. This information may be submitted in any form desired.

Optional Form WH-347 is available for this purpose and may be purchased from the Superintendent of Documents (Federal Stock Number 029-005-00014-1), U.S. Government Printing Office, Washington, D.C. 20402. The prime Contractor is responsible for the submission of copies of payrolls by all subcontractors. (Approved by the Office of Management and Budget under OMB control number 1215-0149).

(ii)(B) Each payroll submitted shall be accompanied by a "Statement of Compliance," signed by the Contractor, or subcontractor or his or her agent who pays or supervises the payment of the persons employed under the contract and shall certify the following:

(1) That the payroll for the payroll period contains the information required to be maintained under paragraph 5.5(a)(3)(i) of Regulations, 29 CFR Part 5 and that such information is correct and complete;

(2) That each laborer or mechanic (including each helper, apprentice, and trainee) employed on the contract during the payroll period has been paid the full weekly wages earned, without rebate, either directly or indirectly, and that no deductions have been made either directly or indirectly from the full wages earned, other than permissible deductions as set forth in Regulations, 29 CFR Part 3;

(3) That each laborer or mechanic has been paid not less than the applicable wage rates and fringe benefits or cash equivalents for the classification of work performed as specified in the applicable wage determination incorporated into the contract.

(ii)(C) The weekly submission of a properly executed certification set forth on the reverse side of Optional Form WH-347 shall satisfy the requirement for submission of the "Statement of Compliance" required by paragraph (a)(3)(ii)(B) of this section.

(ii)(D) The falsification of any of the above certifications may subject the Contractor or subcontractor to civil or criminal prosecution under Section 1001 of Title 18 and Section 231 of Title 31 of the United States Code.

(iii) The Contractor or subcontractor shall make the records required under paragraph (a)(3)(i) of this section available for inspection, copying, or transcription by authorized representatives of the (write the name of the agency) or the Department of Labor, and shall permit such representatives to interview employees during working hours on the job. If the Contractor or subcontractor fails to submit the required records or to make them available, the Federal agency may, after written notice to the Contractor, sponsor, applicant, or owner, take such action as may be necessary to cause the suspension of any further payment, advance, or guarantee of funds. Furthermore, failure to submit the required records upon request or to make such records available may be grounds for debarment action pursuant to 29 CFR 5.12.

(4) Apprentices and Trainees

(i) Apprentices. Apprentices will be permitted to work at less than the predetermined rate for the work they performed when they are employed pursuant to and individually registered in a bona fide apprenticeship program registered with the U.S. Department of Labor, Employment and Training Administration, Bureau of Apprenticeship and Training, or with a State Apprenticeship Agency recognized by the Bureau, or if a person is employed in his or her first 90 days of probationary employment as a apprentice in such an apprenticeship program, who is not individually registered in the program, but who has been certified by the Bureau of Apprenticeship and Training or a State Apprenticeship Agency (where appropriate) to be eligible for probationary employment as an apprentice. The allowable ratio of apprentices to journeymen on the job site in any craft classification shall not be greater than the ratio permitted to the Contractor as to the entire work force under the registered program. Any worker listed on a payroll at an apprentice wage rate, who is not registered or otherwise employed as stated above, shall be paid not less than the applicable wage rate on the wage determination for the classification of work actually performed. In addition, any apprentice performing work on the job site in excess of the ratio permitted under the registered program shall be paid not less than the applicable wage rate on the wage determination for the work actually performed. Where a Contractor is performing construction on a project in a locality other than that in which its program is registered, the ratios and wage rates (expressed in percentages of the journeyman's hourly rate) specified in the Contractor's or subcontractor's registered program shall be observed. Every apprentice must be paid at not less than the rate specified in the registered program for the apprentice's level of progress, expressed as a percentage of the journeymen hourly rate specified in the applicable wage determination. Apprentices shall be paid fringe benefits in accordance with the provisions of the apprenticeship program. If the apprenticeship program does not specify fringe benefits, apprentices must be paid the full amount of fringe benefits listed on the wage determination for the applicable classification. If the Administrator determines that a different practice prevails for the applicable apprentice classification, fringes shall be paid in accordance with that determination. In the event the Bureau of Apprenticeship and Training, or a State Apprenticeship Agency recognized by the Bureau, withdraws approval of an apprenticeship program, the Contractor will no longer be permitted to utilize apprentices at less than the applicable predetermined rate for the work performed until an acceptable program is approved.

(ii) Trainees. Except as provided in 29 CFR 5.16, trainees will not be permitted to work at less than the predetermined rate for the work performed unless they are employed pursuant to and individually registered in a program which has received prior approval, evidenced by formal certification by the U.S. Department of Labor, Employment and Training Administration. The ratio of trainees to journeymen on the job site shall not be greater than permitted under the plan approved by the Employment and Training Administration. Every trainee must be paid at not less than the rate specified in the approved program for the trainee's level of progress, expressed as a percentage of the journeyman hourly rate specified in the applicable wage determination. Trainees shall be paid fringe benefits in accordance with the provisions of the trainee program. If the trainee program does not mention fringe benefits, trainees shall be paid the full amount of fringe benefits listed on the wage determination unless the Administrator of the Wage and Hour Division determines that there is an apprenticeship program associated with the corresponding journeyman wage rate on the wage determination which provides for less than full fringe benefits for apprentices. Any employee listed on the payroll at a trainee rate who is not registered and participating in a training plan approved by the Employment and Training Administration shall be paid not less than the applicable wage rate on the wage determination for the classification of work actually performed. In addition, any trainee performing work on the job site in excess of the ration permitted under the registered program shall be paid not less than the applicable wage rate on the wage determination for the work actually performed. In the event the Employment and Training Administration withdraws approval of a training program, the contract will no longer be permitted to utilize trainees at less than the applicable predetermined rate for the work performed until an acceptable program is approved.

(iii) Equal employment opportunity. The utilization of apprentices, trainees and journeymen under this part shall be in conformity with the equal employment opportunity requirements of Executive Order 11246, as amended, and 29 CFR Part 30.

(5) Compliance with Copeland Act requirements. The Contractor shall comply with the requirements of 29 CFR Part 3, which are incorporated by reference in this contract.

(6) Subcontracts. The Contractor or subcontractor shall insert in any subcontracts the clauses contained in paragraph (a)(1) through (10) of this contract and such other clauses as the Federal Aviation Administration may by appropriate instructions require, and also a clause requiring the subcontractors to include these clauses in any lower tier subcontracts. The prime Contractor shall be responsible for the compliance by an subcontractor or lower tier subcontractor with all the contract clauses in 29 CFR 5.5.

(7) Contract determination: debarment. A breach of these contract clauses paragraphs (a)(1) through (10) and the 2nd clause (b)(1) through (5) below may be grounds for termination of the contract and for debarment as a Contractor and a subcontractor as provided in 29 CFR 5.12.

(8) Compliance with Davis-Bacon and Related Act requirements. All rulings and interpretations of the Davis-Bacon and Related Acts contained in 29 CFR Parts 1, 3, and 5 are herein incorporated by referenced in this contract.

(9) Disputes concerning labor standards. Disputes arising out of the labor standards provisions of this contract shall not be subject to the general disputes clause of this contract. Such disputes shall be resolved in accordance with the procedures of the Department of Labor set forth in 29 CFR Parts 5, 6, and 7. Disputes within the meaning of this clause include disputes between the Contractor (or any of its subcontractors) and the contracting agency, the U.S. Department of Labor, or the employees or their representatives.

(10) Certification of Eligibility.

(i) By entering into this contract, the Contractor certifies that neither it (nor he or she) nor any person or firm who has an interest in the Contractor's firm is a person or firm ineligible to be awarded Government contracts by virtue of section 3(a) of the Davis-Bacon Act or 29 CFR 5.12(a)(1).

(ii) No part of this contract shall be subcontracted to any person or firm ineligible for award of a Government contract by virtue of section 3(a) of the Davis-Bacon Act or 29 CFR 5.12(a)(1).

(iii) The penalty for making false statements is prescribed in the U.S. Criminal Code, 18 U.S.C. 1001.

(b) Contract Work Hours and Safety Standards Act. The Agency Head shall cause or require the contracting officer to insert the following clauses set forth in paragraphs (b)(1), (2), (3), (4) and (5) of this section in full in AIP construction contracts in excess of \$2,000. These clauses shall be inserted in addition to the clauses required by paragraph 5.5(a) or paragraph 4.6 of Part 4 of this title. As used in this paragraph, the terms "laborers" and "mechanics" include watchmen and guards.

(1) Overtime requirements: No Contractor or subcontractor contracting for any part of the contract work which may require or involve the employment of laborers, mechanics, watchmen or guards (including apprentices and trainees described in paragraphs 5 and 6 above) shall require or permit any laborer, mechanic, watchman or guard in any workweek in which he/she is employed on such work, to work in excess of 40 hours in such workweek unless such laborer, mechanic, watchman or guard receives compensation at a rate not less than one and one-half times his/her basic rate of pay for all hours worked in excess of 40 hours in such workweek.

(2) Violations: Liability for Unpaid Wages; Liquidated Damages: In the event of any violation of the clause set forth in subparagraph (1) of this paragraph, the Contractor and any subcontractor responsible therefore shall be liable to any affected employee for his/her unpaid wages. In addition, such Contractor and subcontractor shall be liable to the United States (in case of work done under contract for the District of Columbia or a territory, to such District or to such territory), for liquidated damages. Such liquidated damages shall be computed with respect to each individual laborer, mechanic, watchman or guard employed in violation of the clause set forth in subparagraph (1) of this paragraph, in the sum of \$10.00 for each calendar day on which such employee was required or permitted to work in excess of the standard workweek of 40 hours without payment of the overtime wages required by the clause set forth in subparagraph (1) of this paragraph.

(3) Withholding for unpaid wages and liquidated damages. The (write in the name of the Federal agency or the loan or grant recipient) shall upon its own action or upon written request of an authorized representative of the Department of Labor withhold or cause to be withheld, from any moneys payable on account of work performed by the Contractor or subcontractor under any such contract or any other Federal contract with the same prime Contractor, or any other Federally-assisted contract subject to the Contract Work Hours and Safety Standards Act, which is held by the same prime Contractor, such sums as may be determined to be necessary to satisfy any liabilities of such Contractor or subcontractor for unpaid wages and liquidated damages as provided in the clause set forth in subparagraph (2) of this paragraph.

(4) Subcontracts. The Contractor or subcontractor shall insert in any subcontracts the clauses set forth in subparagraph (1) through (4) of this paragraph and also a clause requiring the subcontractors to include these clauses in any lower tier subcontracts. The prime Contractor shall be responsible for compliance by any subcontractor or lower tier subcontractor with the clauses set forth in subparagraphs (1) through (4) of this paragraph.

(5) Working Conditions. No Contractor or subcontractor may require any laborer or mechanic employed in the performance of any contract to work in surroundings or under working conditions that are unsanitary, hazardous, or dangerous to his health or safety as determined under construction safety and health standards (29 CFR 1926) issued by Department of Labor.

(c) In addition to the clauses contained in paragraph (b), in any contract subject only to the Contract Work Hours and Safety Standards Act and not to any of the other statutes cited in paragraph 5.1, the Agency Head shall cause or require the contracting officer to insert a clause requiring that the Contractor or subcontractor shall maintain payrolls and basic payroll records during the course of the work and shall preserve them for a period of three years from the completion of the contract for all laborers and mechanics, including guards and watchmen, working on the contract. Such records shall contain the name and address of each such employee, social security number, correct classifications, hourly rates of wages paid, daily and weekly number of hours worked, deductions made, and actual wages paid. Further, the Agency Head shall cause or require the contracting officer to insert in any such contract a clause providing that the records to be maintained under this paragraph shall be made available by the Contractor or subcontractor for inspection, copying, or transcription by authorized representatives of the (write the name of agency) and the Department of Labor, and the Contractor or subcontractor will permit such representatives to interview employees during working hours on the job. (Approved by the Office of Management and Budget under OMB control numbers 1215-0140 and 1215-0017).

FEDERAL REGULATIONS VOL. 40, #74,
WEDNESDAY, APRIL 16, 1975, PAGE 17124,
ADMINISTRATION OF THE CLEAR AIR ACT
& WATER POLLUTION CONTROL ACT
(with respect to Federal Grants)

In connection with the administration of the Clean Air Act and the Water Pollution Control Act with respect to Federal Grants, specific requirements have been imposed of any contract which is not exempt under the provisions of 40 CFR 15.5.

(1) Any facility listed on the EPA List of Violating Facilities pursuant to Paragraph 15.20 of 40 CFR as of the date of the contract award will not be utilized in the performance of any non-exempt contract or subcontract.

(2) The Contractor shall comply with all the requirements of Section 114 of the Clean Air Act, as amended, 42 USC 1857 et seq. and Section 308 of the Federal Water Pollution Control Act, as amended, 33 USC 1251 et seq. relating to inspection, monitoring, entry, reports and information, as well as all other requirements specified in Section 114 and Section 308 of the Air Act and Water Act, respectively, and all regulations and guidelines issued thereunder after the award of the contract.

(3) Prompt notification shall be required prior to contract award to the awarding official by the Contractor who will receive the award of the receipt of any communication from the Director, Office of Federal Activities, U.S. Environmental Protection Agency, indicating that a facility to be utilized for the contract is under consideration to be listed on the EPA List of Violating Facilities.

(4) The Contractor shall include or cause to be included the criteria and requirements in paragraphs 1 through 4 in any non-exempt subcontract and will take such action as the Government may direct as a means of enforcing such provisions.

Attachment No. 1

During the performance of the contract, the Contractor agrees as follows:

- (1) The Contractor will not discriminate against any employee or applicant for employment because of race, color, religion, sex or national origin. The Contractor will take affirmative action to ensure that applicants are employed, and that employees are treated during employment without regard to their race, color, religion, sex or national origin. Such action shall include, but not be limited to the following: Employment, upgrading, demotion or transfer, recruitment or recruitment advertising, layoff or termination, rates of pay or other forms of compensation, and selection for training including apprenticeship. The Contractor agrees to post in conspicuous places, available to employees and applicants for employment, notices to be provided setting forth the provisions of this nondiscrimination clause.
- (2) The Contractor will, in all solicitations or advertisements for employees placed by or on the behalf of the Contractor, state that all qualified applicants will receive consideration for employment without regard to race, color, religion, sex or national origin.
- (3) The Contractor will send to each labor union or representative of workers with which he has a collective bargaining agreement or other contract or understanding, a notice to be provided advising the said labor union or worker's representatives of the Contractor's commitments under this section, and shall post copies of the notice in conspicuous places available to employees and applicants for employment.
- (4) The Contractor will comply with all provisions of Executive Order 11246 of September 24, 1965, and of the rules, regulations, and relevant orders of the Secretary of Labor.
- (5) The Contractor will furnish all information and reports required by Executive Order 11246 of September 24, 1965, and by rules, regulations and orders of the Secretary of Labor, or pursuant thereto, and will permit access to his books, records, and accounts by the administering agency and the Secretary of Labor for purposes of investigation to ascertain compliance with such rules, regulations, and orders.
- (6) In the event of the Contractor's noncompliance with the nondiscrimination clauses of this contract or with any of the said rules, regulations, or orders, this contract may be canceled, terminated, or suspended in whole or in part and the Contractor may be declared ineligible for further government contracts or federally assisted construction contracts in accordance with procedures authorized in Executive Order 11246 of 24 September 1965, and such other sanctions may be imposed and remedies invoked as provided in Executive Order 11246 of 24 September 1965, or by rule, regulation or order of the Secretary of Labor, or as otherwise provided by law.
- (7) The Contractor will include the portion of the sentence immediately preceding paragraph (1) and the provisions of paragraphs (1) through (7) in every subcontract or purchase order unless exempted by rules, regulations, or orders of the Secretary of Labor issued pursuant to Section 204 of Executive Order 11246 of 24 September 1965, so that such provisions will be binding upon each subcontractor or vendor. The Contractor will take such action with respect to any subcontract or purchase order as the administering agency may direct as means of enforcing such provisions, including sanctions for noncompliance; provided, however, that in the event a Contractor becomes involved in, or is threatened with, litigation with a subcontractor or vendor as a result of such direction by the administering agency, the Contractor may request the United States to enter into such litigation to protect the interests of the United States.

ATTACHMENT NO. 2

EACH PRIME CONTRACTOR SHALL INSERT IN EACH SUBCONTRACT THE CERTIFICATION IN APPENDIX B, AND FURTHER, SHALL REQUIRE ITS INCLUSION IN ANY LOWER TIER SUBCONTRACT, PURCHASE ORDER, OR TRANSACTION THAT MAY IN TURN BE MADE.

- Appendix B of 49 CFR Part 29 -

This certification applies to subcontractors, material suppliers, vendors and other lower tier participants.

Appendix B--Certification Regarding Debarment, Suspension, Ineligibility and Voluntary Exclusion--Lower Tier Covered Transactions

Instructions for Certification

1. By signing and submitting this proposal, the prospective lower tier participant is providing the certification set out below.

2. The certification in this clause is a material representation of fact upon which reliance was placed when this transaction was entered into. If it is later determined that the prospective lower tier participant knowingly rendered an erroneous certification, in addition to other remedies available to the Federal Government, the department or agency with which this transaction originated may pursue available remedies, including suspension and/or debarment.

3. The prospective lower tier participant shall provide immediate written notice to the person to which this proposal is submitted if at any time the prospective lower tier participant learns that its certification was erroneous when submitted or has become erroneous by reason of changed circumstances.

4. The terms "covered transaction," "debarred," "suspended," "ineligible," "lower tier covered transaction," "participant," "person," "primary covered transaction," "principal," "proposal," and "voluntarily excluded," as used in this clause sections of rules implementing Executive Order 12549. You may contact the person to which this proposal is submitted for assistance in obtaining a copy of those regulations.

5. The prospective lower tier participant agrees by submitting this proposal that, should the proposed covered transaction be entered into, it shall not knowingly enter into any lower tier covered transaction with a person who is debarred, suspended, declared ineligible, or voluntarily excluded from participation in this covered transaction, unless authorized by the department or agency with which this transaction originated.

6. The prospective lower tier participant further agrees by submitting this proposal that it will include this clause titled "Certification Regarding Debarment, Suspension, Ineligibility and Voluntary Exclusion--Lower Tier Covered Transaction," without modification, in all lower tier covered transactions and in all solicitations for lower tier covered transactions.

7. A participant in a covered transaction may rely upon a certification of a prospective participant in a lower tier covered transaction that it is not debarred, suspended, ineligible, or voluntarily excluded from the covered transaction, unless it knows that the certification is erroneous. A participant may decide the method and frequency by which it determines the eligibility of its principals. Each participant may, but is not required to, check the Nonprocurement List.

8. Nothing contained in the foregoing shall be construed to require establishment of a system of records in order to render in good faith the certification required by this clause. The knowledge and information of a participant is not required to exceed that which is normally possessed by a prudent person in the ordinary course of business dealings.

9. Except for transactions authorized under paragraph 5 of these instructions, if a participant in a covered transaction knowingly enters into a lower tier covered transaction with a person who is suspended, debarred, ineligible, or voluntarily excluded from participation in this transaction, in addition to other remedies available to the Federal Government, the department or agency with which this transaction originated may pursue available remedies, including suspension and/or debarment.

Certification Regarding Debarment, Suspension, Ineligibility and Voluntary Exclusion--Lower Tier Covered Transactions

(1) The prospective lower tier participant certifies, by submission of this proposal, that neither it nor its principals is presently debarred, suspended, proposed for debarment, declared ineligible, or voluntarily excluded from participation in this transaction by any Federal department or agency.

(2) Where the prospective lower tier participant is unable to certify to any of the statements in this certification, such prospective participant shall attach an explanation to this proposal.

STATE REQUIRED CONTRACT PROVISIONS
ALL FEDERAL-AID CONSTRUCTION CONTRACTS

Effective February 1, 1969
Revised January 2, 1973

The following provisions are State of Illinois requirements and are in addition to the Federal requirements.

"EQUAL EMPLOYMENT OPPORTUNITY"

In the event of the Contractor's noncompliance with any provisions of this Equal Employment Opportunity Clause, the Illinois Fair Employment Practices Act or the Fair Employment Practices Commission's Rules and Regulations for Public Contracts, the Contractor may be declared nonresponsible and therefore ineligible for future contracts or subcontracts with the State of Illinois or any of its political subdivisions or municipal corporations, and the contract may be canceled or avoided in whole or in part, and such other sanctions or penalties may be imposed or remedies invoked as provided by statute or regulation.

During the performance of this contract, the Contractor agrees as follows:

- (1) That it will not discriminate against any employee or applicant for employment because of race, color, religion, sex, national origin or ancestry; and further that it will examine all job classifications to determine if minority persons or women are underutilized and will take appropriate affirmative action to rectify any such underutilization.
- (2) That, if it hires additional employees in order to perform this contract or any portion hereof, it will determine the availability (in accordance with the Commission's Rules and Regulations for Public Contracts) of minorities and women in the area(s) from which it may reasonably recruit and it will hire for each job classification for which employees are hired in such a way that minorities and women are not underutilized.
- (3) That, in all solicitations or advertisements for employees placed by it or on its behalf, it will state that all applicants will be afforded equal opportunity without discrimination because of race, color, religion, sex, national origin or ancestry.
- (4) That it will send to each labor organization or representative of workers with which it has or is bound by a collective bargaining or other agreement or understanding, a notice advising such labor organization or representative of the Contractor's obligations under the Illinois Fair Employment Practices Act and the Commission's Rules and Regulations for Public Contracts. If any such labor organization or representative fails or refuses to cooperate with the Contractor in its efforts to comply with such Act and Rules and Regulations, the Contractor will promptly so notify the Illinois Fair Employment Practices Commission and the contracting agency and will recruit employees from other sources when necessary to fulfill its obligations thereunder.
- (5) That it will submit reports as required by the Illinois Fair Employment Practices Commission's Rules and Regulations for Public Contracts, furnish all relevant information as may from time to time be requested by the Commission or the contracting agency, and in all respects comply with the Illinois Fair Employment Practices Act and the Commission's Rules and Regulations for Public Contracts.
- (6) That it will permit access to all relevant books, records, accounts and work sites by personnel of the contracting agency and the Illinois Fair Employment Practices Commission for purposes of investigation to ascertain compliance with the Illinois Fair Employment Practices Act and the Commission's Rules and Regulations for Public Contracts.
- (7) That it will include verbatim or by reference the provisions of paragraphs 1 through 7 of this clause in every performance subcontract as defined in Section 2.10(b) of the Commission's Rules and Regulations for Public Contracts so that such provisions will be binding upon every subcontractor; and that it will also so include the provisions or paragraphs 1, 5, 6 and 7 in every supply subcontract as defined in Section 2.10(a) of the Commission's Rules and Regulations for Public Contracts so that such provisions will be binding upon every such subcontractor. In the same manner as with other provisions of this contract, the Contractor will be liable for compliance with applicable provisions of this clause by all its subcontractors; and further it will promptly notify the contracting agency and the Illinois Fair Employment Practices Commission in the event any subcontractor fails or refuses to comply therewith. In addition, no Contractor will utilize any subcontractor declared by the Commission to be nonresponsible and therefore ineligible for contracts or subcontracts with the State of Illinois or any of its political subdivisions or municipal corporations.

CONSTRUCTION CONTRACT PROCUREMENT POLICIES

TABLE OF CONTENTS

SECTION 1

Proposal Requirements and Conditions

SUB-SECTION

1-01 ADVERTISEMENT (Notice to Bidders).....	42
1-02 PREQUALIFICATION OF BIDDERS.....	42
1-03 CONTENTS OF PROPOSAL FORMS	43
1-04 ISSUANCE OF PROPOSAL FORMS.....	43
1-05 INTERPRETATION OF QUANTITIES IN BID SCHEDULE.....	43
1-06 EXAMINATION OF PLANS, SPECIFICATIONS, AND SITE.....	43
1-07 PREPARATION OF THE PROPOSAL	44
1-08 REJECTION OF PROPOSALS	44
1-09 PROPOSAL GUARANTY	44
1-10 DELIVERY OF PROPOSALS	45
1-11 WITHDRAWAL OF PROPOSALS.....	45
1-12 PUBLIC OPENING OF PROPOSALS.....	45
1-13 DISQUALIFICATION OF BIDDERS.....	45
1-14 WORKER'S COMPENSATION INSURANCE.....	45

SECTION 2

Award and Execution of Contract

SUB-SECTION

2-01 CONSIDERATION OF PROPOSALS	45
2-02 AWARD OF CONTRACT	46
2-03 CANCELLATION OF AWARD	46
2-04 RETURN OF PROPOSAL GUARANTY	46
2-05 REQUIREMENT OF PERFORMANCE AND PAYMENT BONDS	46
2-06 EXECUTION OF CONTRACT.....	46
2-07 APPROVAL OF CONTRACT	46
2-08 FAILURE TO EXECUTE CONTRACT	46

SECTION 1

PROPOSAL REQUIREMENTS AND CONDITIONS

1-01 ADVERTISEMENT (Notice to Bidders). The State of Illinois shall publish the advertisement at such places and at such times as are required by local law or ordinances. The published advertisement shall state the time and place for submitting sealed proposals; a description of the proposed work; instructions to bidders as to obtaining proposal forms, plans, and specifications; proposal guaranty required; and the Owner's right to reject any and all bids.

For Federally assisted contracts the advertisement shall conform to the requirements of local laws and ordinances pertaining to letting of contracts and, in addition, shall conform to the requirements of the appropriate parts of the Federal Aviation Regulations applicable to the particular contract being advertised.

1-02 PREQUALIFICATION OF BIDDERS.

- (a) When the awarding authority is the State of Illinois, each prospective bidder, prior to being considered for issuance of any proposal forms will be required to file, on forms furnished by the Department, an experience questionnaire and a confidential financial statement in accordance with the Department's Instructions for Prequalification of Contractors. The Statement shall include a complete report of the prospective bidder's financial resources and liabilities, equipment, past record and personnel, and must be submitted at least thirty (30) days prior to the scheduled opening of bids in which the Contractor is interested.

After the Department has analyzed the submitted "Contractor's Statement of Experience and Financial Condition" and related information and has determined appropriate ratings, the Department will issue to the Contractor a "Certificate of Eligibility". The Certificate will permit the Contractor to obtain proposal forms and plans for any Department of Transportation letting on work which is within the limits of the Contractor's potential as indicated on his "Certificate of Eligibility", subject to any limitations due to present work under contract or pending award as determined from the Contractor's submitted "Affidavit of Availability". Bidders intending to consistently submit proposals shall submit a "Contractor's Statement of Experience and Financial Condition" at least once a year. However, prequalification may be changed during that period upon the submission of additional favorable reports or upon reports of unsatisfactory performance.

Before a proposal is issued, the prospective bidder will be required to furnish an "Affidavit of Availability" indicating the location and amount of all uncompleted work under contract, or pending award, either as principal or subcontractor, as well as a listing of all subcontractors and value of work sublet to others. The prospective bidder may be requested to file a statement showing the amount and condition of equipment which will be available.

Before an award is made, the bidder may be required to furnish an outline of his plans for conducting the work.

- (b) When the awarding authority for contract construction work is the County Board of a county; the Council, the City Council, or the President and Board of Trustees of a city, village or town, each prospective bidder, in evidence of his competence, shall furnish the awarding authority as a prerequisite to the release of proposal forms by the awarding authority, a certified or photostatic copy of a "Certificate of Eligibility" issued by the Department of Transportation, in accordance with Section 1-02(a).

The two low bidders must file within 24 hours after the letting a sworn affidavit, in triplicate, showing all uncompleted contracts awarded to them and all low bids pending award for Federal, State, County, Municipal and private work, using the blank form made available for this affidavit. One copy shall be filed with the awarding authority and two copies with the District Highway Office.

1-03 CONTENTS OF PROPOSAL FORMS. Upon request, the Department will furnish the prequalified bidders a proposal form. This form will state the location and description of the contemplated construction and will show the estimate of the various quantities and kinds of work to be performed or materials to be furnished, and will have a schedule of items for which unit bid prices are invited. The proposal form will state the time in which work must be completed, the amount of the proposal guaranty, labor requirements, and date, time and place of the opening of proposals. The form will also include any special provisions or requirements which vary from or are not contained in these specifications.

All papers bound with or attached to the proposal form are considered a part thereof and must not be detached or altered when the proposal is submitted. Any addenda officially issued by the Department, will be considered a part of the proposal whether attached or not.

For Federally assisted contracts, the proposal shall conform to the requirements of local laws and ordinances pertaining to letting of contracts and, in addition, shall conform to the requirements of the appropriate parts of the Federal Aviation Regulations pertaining to the particular contract being let.

1-04 ISSUANCE OF PROPOSAL FORMS. The Department shall refuse to issue a proposal form for any of the following reasons:

- (a) Lack of competency and adequate machinery, plant and other equipment, as revealed by the financial statement and experience questionnaires required under Section 1-02(a).
- (b) Uncompleted work which, in the judgment of the Department, might hinder or prevent the prompt completion of additional work if awarded.
- (c) False information provided on a bidder's "Affidavit of Availability".
- (d) Failure to pay, or satisfactorily settle, all bills due for labor and material on former contracts in force at the time of issuance of proposal forms.
- (e) Failure to comply with any prequalification regulations of the Department.
- (f) Default under previous contracts.
- (g) Unsatisfactory performance record as shown by past work for the Department, judged from the standpoint of workmanship and progress.
- (h) When the Contractor is suspended from eligibility to bid at a public letting where the contract is awarded by, or require approval of, the Department.
- (i) When any agent, servant, or employee of the prospective bidder currently serves as a member, employee, or agent of a governmental body that is financially involved in the proposed work.
- (j) When any agent, servant, or employee of the prospective bidder has participated in the preparation of plans or specifications for the proposed work.

1-05 INTERPRETATION OF QUANTITIES IN BID SCHEDULE. An estimate of quantities of work to be done and materials to be furnished under these specifications is given in the proposal. It is the result of careful calculations and is believed to be correct. It is given only as a basis for comparison of proposals and the award of the contract. The Owner does not expressly or by implication agree that the actual quantities involved will correspond exactly therewith; nor shall the bidder plead misunderstanding or deception because of such estimates of quantities, or of the character, location, or other conditions pertaining to the work. Payment to the Contractor will be made only for the actual quantities of work performed or materials furnished in accordance with the plans and specifications. It is understood that the quantities may be increased or decreased as provided in the subsection titled ALTERATION OF WORK AND QUANTITIES of Section 20 of the Illinois Standard Specifications for Construction of Airports without in any way invalidating the unit bid prices.

1-06 EXAMINATION OF PLANS, SPECIFICATIONS, AND SITE. The bidder is expected to carefully examine the site of the proposed work, the proposal, plans, specifications, and contract forms. He shall satisfy himself as to the character, quality, and quantities of work to be performed, materials to be furnished, and as to the requirements of the proposed contract. The submission of a proposal shall be prima facie evidence that the bidder has made such examination and is satisfied as to the conditions to be encountered in performing the work and as to the requirements of the proposed contract, plans, and specifications.

Boring logs, underground utilities and other records of subsurface investigations and tests are available for inspection of bidders. It is understood and agreed that such subsurface information, whether included in the plans, specifications, or otherwise made available to the bidder, was obtained and is intended for the Owner's design and estimating purposes only. Such information has been made available for the convenience of all bidders. It is further understood and agreed that each bidder is solely responsible for all assumptions, deductions, or conclusions which he may make or obtain from his examination of the boring logs and other records of subsurface investigations and tests that are furnished by the Owner.

1-07 PREPARATION OF THE PROPOSAL. The bidder shall submit his proposal on the form furnished by the Department. The proposal shall be executed property, and bids shall be made for all items indicated in the proposal form, except that when alternate bids are asked, a bid on more than one alternate for each item is not required, unless otherwise provided. The bidder shall indicate, in figures, a unit price for each of the separate items called for in the proposal; he shall show the products of the respective quantities and unit prices in the column provided for that purpose, and the gross sum shown in the place indicated in the proposal shall be the summation of said products. All writing shall be with ink or typewriter, except the signature of the bidder which shall be written with ink.

If the proposal is made by an individual, his name and business address shall be shown. If made by a firm or partnership, the name and business address of each member of the firm or partnership shall be shown. If made by a corporation, the proposal shall show the names, titles, and business address of the president, secretary, and treasurer, and the seal of the corporation shall be affixed and attested by the secretary.

The proposal shall be issued to a prequalified bidder in the same name and style as the financial statement used for prequalification and shall be submitted in like manner.

1-08 REJECTION OF PROPOSALS. The Department reserves the right to reject proposals for any of the conditions in Article 1-04 or for any of the following reasons:

- (a) More than one proposal for the same work from an individual, firm, partnership, or corporation under the same or different names.
- (b) Evidence of collusion among bidders.
- (c) Unbalanced proposals in which the prices for some items are obviously out of proportion to the prices for other items.
- (d) If the proposal does not contain a unit price for each pay item listed except in the case of authorized alternate pay items or lump sum pay items.
- (e) If the proposal is other than that furnished by the Department; or if the form is altered or any part thereof is detached.
- (f) If there are omissions, erasures, alterations, unauthorized additions, conditional or alternate bids, or irregularities of any kind which may tend to make the proposal incomplete, indefinite, or ambiguous as to its meaning.
- (g) If the bidder adds any provisions reserving the right to accept or reject an award, or to enter into a contract pursuant to an award.
- (h) If the proposal is not accompanied by the proper proposal guaranty.
- (i) If the proposal is prepared with other than ink or typewriter.
- (j) If the proposal is submitted in any other name other than that to whom it was issued by the Department.

1-09 PROPOSAL GUARANTY. Each Proposal shall be accompanied by either a bid bond on the Department of Transportation, Division of Aeronautics form contained in the proposal, executed by a corporate surety company satisfactory to the Department or by a bank cashier's check or a properly certified check for not less than 5 percent of the amount bid.

Bank cashier's checks, or properly certified checks accompanying proposals shall be made payable to the Treasurer, State of Illinois.

1-10 DELIVERY OF PROPOSALS. Each proposal should be submitted in a special envelope furnished by the Department. The blank spaces on the envelope shall be filled in correctly to clearly indicate its contents. When an envelope other than the special one furnished by the Department is used, it shall be of the same general size and shape and be similarly marked to clearly indicate its contents. When sent by mail, the sealed proposal shall be addressed to the Department at the address and in care of the official in whose office the bids are to be received. All proposals shall be filed prior to the time and place specified in the Notice to Bidders. Proposals received after the time for opening of bids will be returned to the bidder unopened.

1-11 WITHDRAWAL OF PROPOSALS. Permission will be given a bidder to withdraw a proposal if he makes his request in writing or by telegram before the time for opening proposals. If a proposal is withdrawn, the bidder will not be permitted to resubmit this proposal at the same letting. With the approval of the Engineer, a bidder may withdraw a proposal and substitute a new proposal prior to the time of opening bids.

1-12 PUBLIC OPENING OF PROPOSALS. Proposals will be opened and read publicly at the time and place specified in the Notice to Bidders. Bidders, their authorized agents, and other interested parties are invited to be present.

1-13 DISQUALIFICATION OF BIDDERS. A bidder shall be considered disqualified for any of the following reasons:

- (a) Submitting more than one proposal from the same partnership, firm, or corporation under the same or different name.
- (b) Evidence of collusion among bidders. Bidders participating in such collusion shall be disqualified as bidders for any future work of the Owner.
- (c) If the bidder is considered to be in "default" for any reason specified in the Subsection 1-04 titled ISSUANCE OF PROPOSAL FORMS of this section.

1-14 WORKER'S COMPENSATION INSURANCE. Prior to the approval of his contract by the Division, the Contractor shall furnish to the Division certificates of insurance covering Worker's Compensation, or satisfactory evidence that this liability is otherwise taken care of in accordance with Section 4.(a) of the "Worker's Compensation Act of the State of Illinois" as amended.

SECTION 2

AWARD AND EXECUTION OF CONTRACT

2-01 CONSIDERATION OF PROPOSALS. After the proposals are publicly opened and read, they will be compared on the basis of the summation of the products obtained by multiplying the estimated quantities shown in the proposal by the unit bid prices. In the event of a discrepancy between unit bid prices and extensions, the unit bid price shall govern.

Until the award of a contract is made, the Owner reserves the right to reject a bidder's proposal for any of the following reasons:

- (a) If the proposal is irregular as specified in the subsection titled REJECTION OF PROPOSALS of Section 1.
- (b) If the bidder is disqualified for any of the reasons specified in the subsection titled DISQUALIFICATION OF BIDDERS of Section 1.

In addition, until the award of a contract is made, the Owner reserves the right to reject any or all proposals; waive technicalities, if such waiver is in the best interest of the Owner and is in conformance with applicable State and Local laws or regulations pertaining to the letting of construction contracts; advertise for new proposals; or proceed with the work otherwise.

2-02 AWARD OF CONTRACT. The award of contract will be made within 60 calendar days after the opening of proposals to the lowest responsible and qualified bidder whose proposal complies with all the requirements prescribed. The successful bidder will be notified by letter, that his bid has been accepted, and that he has been awarded the contract.

If a contract is not awarded within 60 days after the opening of proposals, a bidder may file a written request with the Division for the withdrawal of his bid and the Division will permit such withdrawal.

For Federally assisted contracts, unless otherwise specified in this subsection, no award shall be made until the FAA has concurred in the Owner's recommendation to make such award and has approved the Owner's proposal contract to the extent that such concurrence and approval are required by Federal Regulations.

2-03 CANCELLATION OF AWARD. The Division reserves the right to cancel the award without liability to the bidder at any time before a contract has been fully executed by all parties and is approved by the Owner in accordance with the subsection titled APPROVAL OF CONTRACT of this section. The Division at the time of cancellation will return the proposal guaranty.

2-04 RETURN OF PROPOSAL GUARANTY. The proposal guaranties of all except the two lowest bidders will be returned promptly after the proposals have been checked, tabulated, and the relation of the proposals established. Proposal guaranties of the two lowest bidders will be returned as soon as the Construction Contract, Performance Bonds, and Payment Bonds of the successful bidder have been properly executed and approved.

If any other form of proposal guaranty is used, other than a bid bond, a bid bond may be substituted at the Contractor's option.

2-05 REQUIREMENT OF PERFORMANCE AND PAYMENT BONDS. The successful bidder for a contract, at the time of the execution of the contract, shall deposit with the Division separate performance and payment bonds each for the full amount of the contract. The form of the bonds shall be that furnished by the Division, and the sureties shall be acceptable to the Division.

2-06 EXECUTION OF CONTRACT. The successful bidder shall sign (execute) the Contract and shall return the signed Contract to the Owner (Sponsor) for signature (execution) and subsequently return all copies to the Division. The fully executed surety bonds specified in the subsection title REQUIREMENTS OF PERFORMANCE AND PAYMENT BONDS of this section will be forwarded to the Division within 15 days of the date mailed or otherwise delivered to the successful bidder. If the Contract and Bonds are mailed, special handling is recommended.

If the bidder to whom award is to be made is a corporation organized under the laws of a State other than Illinois, the bidder shall furnish the Division a copy of the corporation's certificate of authority to do business in the State of Illinois with the return of the executed contract and bond. Failure to furnish such evidence of a certificate of authority within the time required will be considered as just cause for the annulment of the award and the forfeiture of the proposal guaranty to the State, not as a penalty, but in payment of liquidated damages sustained as a result of such failure.

2-07 APPROVAL OF CONTRACT. Upon receipt of the contract and bonds that have been executed by the successful bidder, the Owner shall complete the execution of the contract in accordance with local laws or ordinances, and return the contract to the Division for approval and execution by the Division. Delivery of the fully executed contract to the Contractor shall constitute the Department's approval to be bound by the successful bidder's proposal and the terms of the contract.

2-08 FAILURE TO EXECUTE CONTRACT. If the contract is not executed by the Division within 15 days following receipt from the bidder of the properly executed contracts and bonds, the bidder shall have the right to withdraw his bid without penalty.

Failure of the successful bidder to execute the contract and file acceptable bonds within 15 days after the contract has been mailed to him shall be just cause for the cancellation of the award and the forfeiture of the proposal guaranty which shall become the property of the State, not as a penalty, but as liquidation of damages sustained.

ILLINOIS DEPARTMENT OF TRANSPORTATION

DIVISION OF AERONAUTICS

The requirements of the following provisions written for Federally-assisted construction contracts, including all goals and timetables and affirmative action steps, shall also apply to all State-funded construction contracts awarded by the Illinois Department of Transportation.

NOTICE OF REQUIREMENT FOR AFFIRMATIVE ACTION TO ENSURE EQUAL EMPLOYMENT OPPORTUNITY (EXECUTIVE ORDER 11246)

1. The Offeror's or Bidder's attention is called to the "Equal Opportunity Clause" and the "Standard Federal Equal Employment Opportunity Construction Contract Specifications" set forth herein.

2. The goals and timetables for minority and female participation, expressed in percentage terms for the Contractor's aggregate workforce in each trade on all construction work in the covered area, are as follows:

APPENDIX A

The following goal for female utilization in each construction craft and trade shall apply to all Contractors holding Federal and federally assisted construction contracts and subcontracts in excess of \$10,000. The goal is applicable to the Contractor's total on-site construction workforce, regardless of whether or not part of that workforce is performing work on a Federal, federally assisted or nonfederally related construction contract or subcontract.

AREA COVERED (STATEWIDE)

Goals for Women apply nationwide.

GOAL

	Goal (percent)
Female Utilization.....	... 6.9

APPENDIX B

Until further notice, the following goals for minority utilization in each construction craft and trade shall apply to all Contractors holding Federal and federally-assisted construction contracts and subcontracts in excess of \$10,000. to be performed in the respective geographical areas. The goals are applicable to the Contractor's total on-site construction workforce, regardless of whether or not part of that workforce is performing work on a Federal, federally-assisted or nonfederally related construction contract or subcontract.

<u>Economic Area</u>	<u>Goal (percent)</u>
056 Paducah, KY:	
Non-SMSA Counties -	5.2
IL - Hardin, Massac, Pope	
KY - Ballard, Caldwell, Calloway, Carlisle, Crittenden,	
Fulton, Graves, Hickman, Livingston, Lyon, McCracken, Marshall	

Revised 08-31-83

<u>Economic Area</u>	<u>Goal (percent)</u>
080 Evansville, IN:	
Non-SMSA Counties -	3.5
IL - Edwards, Gallatin, Hamilton, Lawrence, Saline, Wabash, White	
IN - Dubois, Knox, Perry, Pike, Spencer	
KY - Hancock, Hopkins, McLean, Mublenberg, Ohio, Union, Webster	
081 Terre Haute, IN:	
Non-SMSA Counties -	2.5
IL - Clark, Crawford	
IN - Parke	
083 Chicago, IL:	
SMSA Counties:	19.6
1600 Chicago, IL -	
IL - Cook, DuPage, Kane, Lake, McHenry, Will	
3740 Kankakee, IL -	9.1
IL - Kankakee	
Non-SMSA Counties	18.4
IL - Bureau, DeKalb, Grundy, Iroquois, Kendall, LaSalle, Livingston, Putnam	
IN - Jasper, Laporte, Newton, Pulaski, Starke	
084 Champaign - Urbana, IL:	
SMSA Counties:	
1400 Champaign - Urbana - Rantoul, IL -	7.8
IL - Champaign	
Non-SMSA Counties -	4.8
IL - Coles, Cumberland, Douglas, Edgar, Ford, Piatt, Vermilion	
085 Springfield - Decatur, IL:	
SMSA Counties:	
2040 Decatur, IL -	7.6
IL - Macon	
7880 Springfield, IL -	4.5
IL - Mendard, Sangamon	
Non-SMSA Counties	4.0
IL - Cass, Christian, Dewitt, Logan, Morgan, Moultrie, Scott, Shelby	
086 Quincy, IL:	
Non-SMSA Counties	3.1
IL - Adams, Brown, Pike	
MO - Lewis, Marion, Pike, Ralls	
087 Peoria, IL:	
SMSA Counties:	
1040 Bloomington - Normal, IL -	2.5
IL - McLean	

Revised 08-31-83

APPENDIX B (CONTINUED)

<u>Economic Area</u>	<u>Goal (percent)</u>
6120 Peoria, IL - IL - Peoria, Tazewell, Woodford	4.4
Non-SMSA Counties - IL - Fulton, Knox, McDonough, Marshall, Mason, Schuyler, Stark, Warren	3.3
088 Rockford, IL: SMSA Counties: 6880 Rockford, IL - IL - Boone, Winnebago	6.3
Non-SMSA Counties - IL - Lee, Ogle, Stephenson	4.6
098 Dubuque, IA: Non-SMSA Counties - IL - JoDaviess IA - Atlamakee, Clayton, Delaware, Jackson, Winnesheik WI - Crawford, Grant, Lafayette	0.5
099 Davenport, Rock Island, Moline, IA - IL: SMSA Counties: 1960 Davenport, Rock Island, Moline, IA - IL - IL - Henry, Rock Island IA - Scott	4.6
Non-SMSA Counties - IL - Carroll, Hancock, Henderson, Mercer, Whiteside IA - Clinton, DesMoines, Henry, Lee, Louisa, Muscatine MO - Clark	3.4
107 St. Louis, MO: SMSA Counties: 7040 St. Louis, MO - IL - IL - Clinton, Madison, Monroe, St. Clair MO - Franklin, Jefferson, St. Charles, St. Louis, St. Louis City	14.7
Non-SMSA Counties - IL - Alexander, Bond, Calhoun, Clay, Effingham, Fayette, Franklin, Greene, Jackson, Jasper, Jefferson, Jersey, Johnson, Macoupin, Marion, Montgomery, Perry, Pulaski, Randolph, Richland, Union, Washington, Wayne, Williamson MO - Bollinger, Butler, Cape Girardeau, Carter, Crawford, Dent, Gasconade, Iron, Lincoln, Madison, Maries, Mississippi, Montgomery, Perry, Phelps, Reynolds, Ripley, St. Francois, St. Genevieve, Scott, Stoddard, Warren, Washington, Wayne	11.4

Revised 08-31-83

These goals are applicable to all the Contractor's construction work (whether or not it is Federal or federally assisted) performed in the covered area. If the Contractor performs construction work in a geographical area located outside of the covered area, it shall apply the goals established for such geographical area where the work is actually performed. With regard to this second area, the Contractor also is subject to the goals for both its federally involved and nonfederally involved construction.

The Contractor's compliance with Executive Order and the regulations in 41 CFR Part 60-4 shall be based on its implementation of the Equal Opportunity Clause, specific affirmative action obligations required by the provisions and specifications set forth in its federally assisted contracts, and its efforts to meet the goals established for the geographical area where the contract resulting from this solicitation is to be performed. The hours of minority and female employment and training must be substantially uniform throughout the length of the contract, and in each trade, and the Contractor shall make a good faith effort to employ minorities and women evenly on each of its projects. The transfer of minority or female employees or trainees from Contractor to Contractor or from project to project for the sole purpose of meeting the Contractor's goals shall be a violation of the contract, the Executive Order and the regulations in 41 CFR Part 60-4. Compliance with the goals will be measured against the total work hours performed.

3. The Illinois Division of Aeronautics will provide written notification to the Director of the Office of Federal Contract Compliance Programs within 10 working days of award of any construction contract and/or subcontract in excess of \$10,000 at any tier for construction work under the contract resulting from this solicitation. This notification will list the name, address and telephone number of the subcontractor; employer identification number; estimated dollar amount of the subcontract; estimated starting and completion dates of the subcontract; and the geographical area in which the contract is to be performed.

4. As used in this Notice, and in the contract resulting from this solicitation, the "covered area" is the entire State of Illinois for the goal set forth in APPENDIX A and the county or counties in which the work is located for the goals set forth in APPENDIX B.

STANDARD FEDERAL EQUAL EMPLOYMENT
OPPORTUNITY CONSTRUCTION CONTRACT
SPECIFICATIONS (EXECUTIVE ORDER 11246)

1. As used in these specifications:
 - a) "Covered area" means the geographical area described in the solicitation from which this contract resulted;
 - b) "Director" means Director, Office of Federal Contract Compliance Programs, United States Department of Labor, or any person to whom the Director delegates authority;
 - c) "Employer identification number" means the Federal Social Security number used on the Employer's Quarterly Federal Tax Return, U.S. Treasury Department Form 941;
 - d) "Minority" includes:
 - (i) Black (all persons having origins in any of the Black African racial groups not of Hispanic origin);
 - (ii) Hispanic (all persons of Mexican, Puerto Rican, Cuban, Central or South American or other Spanish Culture or origin, regardless of race);
 - (iii) Asian and Pacific Islander (all persons having origins in any of the original peoples of the Far East, Southeast Asia, the Indian Subcontinent, or the Pacific Islands); and
 - (iv) American Indian or Alaskan Native (all persons having origins in any of the original peoples of North America and maintaining identifiable tribal affiliations through membership and participation or community identification).
2. Whenever the Contractor, or any Subcontractor at any tier, subcontracts a portion of the work involving any construction trade, it shall physically include in each subcontract in excess of \$10,000. the provisions of these specifications and the Notice which contains the applicable goals for minority and female participation and which is set forth in the solicitations from which this contract resulted.

Revised 08-31-83

3. If the Contractor is participating (pursuant to 41 CFR 60-4.5) in a Hometown Plan approved by the U.S. Department of Labor in the covered area either individually or through an association, its affirmative action obligations on all work in the plan area (including goals and timetables) shall be in accordance with that Plan for those trades which have unions participating in the Plan. Contractors must be able to demonstrate their participation in and compliance with the provisions of any such Hometown Plan. Each Contractor or Subcontractor participating in an approved Plan is individually required to comply with its obligations under the EEO clause, and to make a good faith effort to achieve each goal under the Plan in each trade in which it has employees. The overall good faith performance by other Contractors or Subcontractors toward a goal in an approved Plan does not excuse any covered Contractor's or Subcontractor's failure to take good faith efforts to achieve the Plan goals and timetables.
4. The Contractor shall implement the specific affirmative action standards provided in paragraphs 7a through p of these specifications. The goals set forth in the solicitation from which this contract resulted are expressed as percentages of the total hours of employment and training of minority and female utilization the Contractor should reasonably be able to achieve in each construction trade in which it has employees in the covered area. Covered Construction Contractors performing construction work in geographical areas where they do not have a Federal or federally assisted construction contract shall apply the minority and female goals established for the geographical area where the work is being performed. Goals are published periodically in the Federal Register in notice form, and such notices may be obtained from any Office of Federal Contract Compliance Programs office or from Federal procurement contracting officers. The Contractor is expected to make substantially uniform progress toward its goals in each craft during the period specified.
5. Neither the provisions of any collective bargaining agreement, nor the failure by a union with whom the Contractor has a collective bargaining agreement, to refer either minorities or women shall excuse the Contractor's obligations under these specifications, Executive Order 11246, or the regulations promulgated pursuant thereto.
6. In order for the nonworking training hours of apprentices and trainees to be counted in meeting the goals, such apprentices and trainees must be employed by the Contractor during the training period, and the Contractor must have made a commitment to employ the apprentices and trainees at the completion of their training, subject to the availability of employment opportunities. Trainees must be trained pursuant to training programs approved by the U.S. Department of Labor.
7. The Contractor shall take specific affirmative actions to ensure equal employment opportunity. The evaluation of the Contractor's compliance with these specifications shall be based upon its effort to achieve maximum results from its actions. The Contractor shall document these efforts fully, and shall implement affirmative action steps at least as extensive as the following:
 - a) Ensure and maintain a working environment free of harassment, intimidation, and coercion at all sites, and in all facilities at which the Contractor's employees are assigned to work. The Contractor, where possible, will assign two or more women to each construction project. The Contractor shall specifically ensure that all foremen, superintendents, and other on-site supervisory personnel are aware of and carry out the Contractor's obligation to maintain such a working environment, with specific attention to minority or female individuals working as such sites or in such facilities.
 - b) Establish and maintain a current list of minority and female recruitment sources, provide written notification to minority and female recruitment sources and to community organizations when the Contractor or its unions have employment opportunities available, and maintain a record of the organizations' responses.
 - c) Maintain a current file of the names, addresses and telephone numbers of each minority and female off-the-street applicant and minority or female referral from a union, a recruitment source or community organization and of what action was taken with respect to each such individual. If such individual was sent to the union hiring hall for referral and was not referred back to the Contractor by the union or, if referred, not employed by the Contractor, this shall be documented in the file with the reason therefor, along with whatever additional actions the Contractors may have taken.

Revised 08-31-83

- d) Provide immediate written notification to the Director when the union or unions with which the Contractor has a collective bargaining agreement has not referred to the Contractor a minority person or woman sent by the Contractor, or when the Contractor has other information that the union referral process has impeded the Contractor's efforts to meet its obligations.
- e) Develop on-the-job training opportunities and/or participate in training programs for the area which expressly include minorities and women, including upgrading programs and apprenticeship and trainee programs relevant to the Contractor's employment needs, especially those programs funded or approved by the Department of Labor. The Contractor shall provide notice of these programs to the sources compiled under 7b above.
- f) Disseminate the Contractor's EEO policy by providing notice of the policy to unions and training programs and requesting their cooperation in assisting the Contractor in meeting its EEO obligations; by including it in any policy manual and collective bargaining agreements; by publicizing it in the company newspaper, annual report, etc.; by specific review of the policy with all management personnel and with all minority and female employees at least once a year; and by posting the company EEO policy on bulletin boards accessible to all employees at each location where construction work is performed.
- g) Review, at least annually, the company's EEO policy and affirmative action obligations under these specifications with all employees having any responsibility for hiring, assignment, layoff, termination or other employment decisions including specific review of these items with onsite supervisory personnel such as Superintendents, General Foreman, etc., prior to the initiation of construction work at any job site. A written record shall be made and maintained identifying the time and place of these meetings, persons attending, subject matter discussed, and disposition of the subject matter.
- h) Disseminate the Contractor's EEO policy externally by including it in any advertising in the news media, specifically including minority and female news media, and providing written notification to and discussing the Contractor's EEO policy with other Contractors and Subcontractors with whom the Contractor does or anticipates doing business.
- i) Direct its recruitment efforts, both oral and written, to minority, female and community organizations, to schools with minority and female students and to minority and female recruitment and training organizations serving the Contractor's recruitment area and employment needs. Not later than one month prior to the date for the acceptance of applications for apprenticeship or other training by any recruitment source, the Contractor shall send written notification to organizations such as the above, describing the openings, screening procedures, and tests to be used in the selection process.
- j) Encourage present minority and female employees to recruit other minority persons and women and, where reasonable, provide after school, summer and vacation employment to minority and female youth both on the site and in other areas of a Contractor's workforce.
- k) Validate all tests and other selection requirements where there is an obligation to do so under 41 CFR Part 60-3.
- l) Conduct, at least annually, an inventory and evaluation at least of all minority and female personnel for promotional opportunities and encourage these employees to seek or to prepare for, through appropriate training, etc., such opportunities.
- m) Ensure that seniority practices, job classifications, work assignments and other personnel practices, do not have a discriminatory effect by continually monitoring all personnel and employment related activities to ensure that the EEO policy and the Contractor's obligations under these specifications are being carried out.
- n) Ensure that all facilities and company activities are nonsegregated except that separate or single-user toilet and necessary changing facilities shall be provided to assure privacy between the sexes.
- o) Document and maintain a record of all solicitations of offers for subcontracts from minority and female construction Contractors and suppliers, including circulation of solicitations to minority and female Contractor associations and other business associations.

Revised 08-31-83

- p) Conduct a review, at least annually, of all supervisors' adherence to and performance under the Contractor's EEO policies and affirmative action obligations.
8. Contractors are encouraged to participate in voluntary associations which assist in fulfilling one or more of their affirmative action obligations (7a through p). The efforts of a Contractor association, joint Contractor-union, Contractor-community, or other similar group of which the Contractor is a member and participant, may be asserted as fulfilling any one or more of its obligations under 7a through p of these Specifications provided that the Contractor actively participates in the group, makes every effort to assure that the group has a positive impact on the employment of minorities and women in the industry, ensures that the concrete benefits of the program are reflected in the Contractor's minority and female workforce participation makes a good faith effort to meet its individual goals and timetables, and can provide access to documentation which demonstrates the effectiveness of actions taken on behalf of the Contractor. The obligation to comply, however, is the Contractor's and failure of such a group to fulfill an obligation shall not be a defense for the Contractor's noncompliance.
9. A single goal for minorities and a separate single goal for women have been established. The Contractor, however, is required to provide equal employment opportunity and to take affirmative action for all minority groups, both male and female, and all women, both minority and non-minority. Consequently, the Contractor may be in violation of the Executive Order if a particular group is employed in a substantially disparate manner (for example, even though the Contractor has achieved its goals for women generally, the Contractor may be in violation of the Executive Order if a specified minority group of women is underutilized).
10. The Contractor shall not use the goals and timetables or affirmative action standards to discriminate against any person because of race, color, religion, sex, or national origin.
11. The Contractor shall not enter into any Subcontract with any person or firm debarred from Government contracts pursuant to Executive Order 11246.
12. The Contractor shall carry out such sanctions and penalties for violation of these specifications and of the Equal Opportunity Clause, including suspension, termination and cancellation of existing subcontracts as may be imposed or ordered pursuant to Executive Order 11246, as amended, and its implementing regulations, by the Office of Federal Contract Compliance Programs. Any Contractor who fails to carry out such sanctions and penalties shall be in violation of these specifications and Executive Order 11246, as amended.
13. The Contractor, in fulfilling its obligations under these specifications, shall implement specific affirmative action steps, at least as extensive as those standards prescribed in paragraph 7 of these specifications, so as to achieve maximum results from its efforts to ensure equal opportunity. If the Contractor fails to comply with the requirements of the Executive Order, the implementing regulations, or these specifications, the Director shall proceed in accordance with 41 CFR 60-4.8.
14. The Contractor shall designate a responsible official to monitor all employment related activity to ensure that the company EEO policy is being carried out, to submit reports relating to the provisions hereof as may be required by the Government and to keep records. Records shall at least include for each employee the name, address, telephone numbers, construction trade, union affiliation if any, employee identification number when assigned, social security number, race, sex, status (e.g., mechanic, apprentice, trainee, helper, or laborer), dates of changes in status, hours worked per week in the indicated trade, rate of pay, and locations at which the work was performed. Records shall be maintained in an easily understandable and retrievable form; however, to the degree that existing records satisfy his requirement, Contractors shall not be required to maintain separate records.
15. Nothing herein provided shall be construed as a limitation upon the application of other laws which establish different standards of compliance or upon the application of requirements for the hiring of local or other area residents (e.g., those under the Public Works Employment Act of 1977 and the Community Development Block Grant Program).

Revised 08-31-83

ANNUAL EEO-1 REPORT TO JOINT REPORTING COMMITTEE AS REQUIRED AT

41 CFR 60-1.7(a)

Any Contractor having a Federal contract of \$50,000 or more and 50 or more employees is required to file annual compliance reports on Standard Form 100 (EEO-1) with the Joint Reporting Committee in accordance with the instructions provided with the form. The Contractor will provide a copy of such a report to the contracting agency within 30 days after the award of a contract.

The Contractor shall require its subcontractors to file an SF 100 within 30 days after award of the subcontract if (1) it is not exempt from the provisions of these regulations in accordance with 60-1.5, (2) has 50 or more employees, (3) first tier subcontractor, and (4) has a subcontract amounting to \$50,000 or more.

Subcontractors below the first tier which perform construction work at the site of construction shall be required to file such a report if (1) it is not exempt from the provisions of these regulations in accordance with 60-1.5, (2) has 50 or more employees and has a subcontract amounting to \$50,000 or more.

The SF 100 is available at the following address:

Joint Reports Committee
EEOC - Survey Division
1801 "L" Street N.W.
Washington, D.C. 20750

Phone (202) 663-4968

DISADVANTAGED BUSINESS POLICY

I. NOTICE

This proposal contains the special provision entitled “Required Disadvantaged Business Participation.” Inclusion of this Special Provision in this contract satisfies the obligations of the Department of Transportation under federal law as implemented by 49 CFR 23 and under the Illinois “Minority and Female Business Enterprise Act.”

II. POLICY

It is public policy that the businesses defined in 49 CFR Part 23 shall have the maximum opportunity to participate in the performance of contracts financed in whole or in part with State or Federal funds. Consequently, the requirements of 49 CFR Part 23 apply to this contract.

III. OBLIGATION

The Contractor agrees to ensure that the businesses defined in 49 CFR Part 23 have the maximum opportunity to participate in the performance of this contract. In this regard, the Contractor shall take all necessary and reasonable steps, in accordance with 49 CFR Part 23, to ensure that the said businesses have the maximum opportunity to compete for and perform portions of this contract. The Contractor shall not discriminate on the basis of race, color, national origin, or sex in the selection and retention of subcontractors, including procurement of materials and leases of equipment.

The Contractor shall include the above Policy and Obligation statements of this Special Provision in every subcontract, including procurement of materials and leases of equipment.

IV. DBE/WBE CONTRACTOR FINANCE PROGRAM

On contracts where a loan has been obtained through the DBE/WBE Contractor Finance Program, the Contractor shall cooperate with the Department by making all payments due to the DBE/WBE Contractor by means of a two-payee check payable to the Lender (Bank) and the Borrower (DBE/WBE Contractor).

V. BREACH OF CONTRACT

Failure to carry out the requirements set forth above and in the Special Provision shall constitute a breach of contract and may result in termination of the contract or liquidated damages as provided in the special provision.

(Rev. 9/21/92)

State of Illinois
Department of Transportation

SPECIAL PROVISION
FOR
DISADVANTAGED BUSINESS ENTERPRISE PARTICIPATION

- I. **FEDERAL OBLIGATION:** The Department of Transportation, as a recipient of federal financial assistance, is required to take all necessary and reasonable steps to ensure nondiscrimination in the award and administration of contracts. Consequently, the federal regulatory provisions of 49 CFR part 26 apply to this contract concerning the utilization of disadvantaged business enterprises. This Special Provision will also be used by the Department to satisfy the requirements of the Business Enterprise for Minorities, Females, and Persons with Disabilities Act, 30 ILCS 575. For the purposes of this Special Provision, a disadvantaged business enterprise (DBE) means a business certified by the Department in accordance with the requirements of 49 CFR part 26 and listed in the DBE Directory or most recent addendum.
- II. **CONTRACTOR ASSURANCE:** The Contractor makes the following assurance and agrees to include the assurance in each subcontract that the Contractor signs with a subcontractor:
- The contractor, subrecipient or subcontractor shall not discriminate on the basis of race, color, national origin, or sex in the performance of this contract. The contractor shall carry out applicable requirements of 49 CFR part 26 in the award and administration of federally-assisted contracts. Failure by the contractor to carry out these requirements is a material breach of this contract, which may result in the termination of this contract or such other remedy as the recipient deems appropriate.
- III. **OVERALL GOAL SET FOR THE DEPARTMENT:** As a requirement of compliance with 49 CFR part 26, the Department has set an overall goal for DBE participation in its federally assisted contracts. That goal is 22.77% of all federal-aid funds the Department will expend in its federally assisted contracts for the subject reporting fiscal year. The Department is required to make a good faith effort to achieve this goal. The dollar amount paid to all approved DBE firms performing work called for in this contract is eligible to be credited toward fulfillment of the Department's overall goal.
- IV. **CONTRACT GOAL TO BE ACHIEVED BY THE CONTRACTOR:** This contract includes a specific DBE utilization goal established by the Department. The goal has been included because the Department has determined that the work of this contract has subcontracting opportunities that may be suitable for performance by DBE companies. This determination is based on an assessment of the type of work, the location of the work, and the availability of DBE companies to do a part of the work. The assessment indicates that, in the absence of unlawful discrimination, and in an arena of fair and open competition, DBE companies can be expected to perform **18.0%** of the work. This percentage is set as the DBE participation goal for this contract. Consequently, in addition to the other award criteria established for this contract, the Department will award this contract to a bidder who makes a good faith effort to meet this goal of DBE participation in the performance of the work. A bidder makes a good faith effort for award consideration if either of the following is done in accordance with the procedures set forth in this Special Provision:
- A. The bidder documents that firmly committed DBE participation has been obtained to meet the goal; or
- B. The bidder documents that a good faith effort has been made to meet the goal, even though the effort did not succeed in obtaining enough DBE participation to meet the goal.

- V. DBE LOCATOR REFERENCES: Bidders may consult the DBE Directory as a reference source for DBE companies certified by the Department. In addition, the Department maintains a letting and item specific DBE locator information system whereby DBE companies can register their interest in providing quotes on particular bid items advertised for letting. Information concerning DBE companies willing to quote work for particular contracts may be obtained by contacting the Department's Bureau of Small Business Enterprises at telephone number (217)785-4611, or by visiting the Department's web site at www.dot.state.il.us.
- VI. BIDDING PROCEDURES: Compliance with the bidding procedures of this Special Provision is required prior to the award of the contract and the failure of the as-read low bidder to comply will render the bid nonresponsive.
- A. In order to assure the timely award of the contract, the as-read low bidder must submit a Disadvantaged Business Utilization Plan on Department form SBE 2026 within seven (7) working days after the date of letting. To meet the seven (7) day requirement, the bidder may send the Plan by certified mail or delivery service within the seven (7) working day period. If a question arises concerning the mailing date of a Plan, the mailing date will be established by the U.S. Postal Service postmark on the original certified mail receipt from the U.S. Postal Service or the receipt issued by a delivery service. It is the responsibility of the as-read low bidder to ensure that the postmark or receipt date is affixed within the seven (7) working days if the bidder intends to rely upon mailing or delivery to satisfy the submission day requirement. The Plan is to be submitted to the Department of Transportation, Bureau of Small Business Enterprises, Contract Compliance Section, 2300 South Dirksen Parkway, Room 319, Springfield, Illinois 62764 (Telefax: (217) 785-1524). It is the responsibility of the bidder to obtain confirmation of telefax delivery. The Department will not accept a Utilization Plan if it does not meet the seven (7) day submittal requirement, and the bid will be declared nonresponsive. In the event the bid is declared nonresponsive due to a failure to submit a Plan or failure to comply with the bidding procedures set forth herein, the Department may elect to cause the forfeiture of the penal sum of the bidder's proposal guaranty, and may deny authorization to bid the project if re-advertised for bids. The Department reserves the right to invite any other bidder to submit a Utilization Plan at any time for award consideration or to extend the time for award.
- B. The Utilization Plan shall indicate that the bidder either has obtained sufficient DBE participation commitments to meet the contract goal or has not obtained enough DBE participation commitments in spite of a good faith effort to meet the goal. The Utilization Plan shall further provide the name, telephone number and telefax number of a responsible official of the bidder designated for purposes of notification of plan approval or disapproval under the procedures of this Special Provision.
- C. The Utilization Plan shall include a DBE Participation Commitment Statement, Department form SBE 2025, for each DBE proposed for the performance of work to achieve the contract goal. The signatures on these forms must be original signatures. All elements of information indicated on the said form shall be provided, including but not limited to the following:
1. The name and address of each DBE to be used;
 2. A description, including pay item numbers, of the commercially useful work to be done by each DBE;
 3. The price to be paid to each DBE for the identified work specifically stating the quantity, unit price and total subcontract price for the work to be completed by the DBE. If partial pay items are to be performed by the DBE, indicate the portion of each item, a unit price where appropriate and the subcontract price amount;
 4. A commitment statement signed by the bidder and each DBE evidencing availability and intent to perform commercially useful work on the project; and
 5. If the bidder is a joint venture comprised of DBE firms and non-DBE firms, the plan must also include a clear identification of the portion of the work to be performed by the DBE partner(s).

D. The contract will not be awarded until the Utilization Plan submitted by the bidder is approved. The Utilization Plan will be approved by the Department if the Plan commits sufficient commercially useful DBE work performance to meet the contract goal. The Utilization Plan will not be approved by the Department if the Plan does not commit sufficient DBE performance to meet the contract goal unless the bidder documents that it made a good faith effort to meet the goal. The good faith procedures of Section VIII of this special provision apply. If the Utilization Plan is not approved because it is deficient in a technical matter, unless waived by the Department, the bidder will be notified and will be allowed no less than a five (5) working day period in order to cure the deficiency.

VII. CALCULATING DBE PARTICIPATION: The Utilization Plan values represent work anticipated to be performed and paid for upon satisfactory completion. The Department is only able to count toward the achievement of the overall goal and the contract goal the value of payments made for the work actually performed by DBE companies. In addition, a DBE must perform a commercially useful function on the contract to be counted. A commercially useful function is generally performed when the DBE is responsible for the work and is carrying out its responsibilities by actually performing, managing, and supervising the work involved. The Department and Contractor are governed by the provisions of 49 CFR part 26.55(c) on questions of commercially useful functions as it affects the work. Specific counting guidelines are provided in 49 CFR part 26.55, the provisions of which govern over the summary contained herein.

A. DBE as the Contractor: 100% goal credit for that portion of the work performed by the DBE's own forces, including the cost of materials and supplies. Work that a DBE subcontracts to a non-DBE firm does not count toward the DBE goals.

B. DBE as a joint venture Contractor: 100% goal credit for that portion of the total dollar value of the contract equal to the distinct, clearly defined portion of the work performed by the DBE's own forces.

C. DBE as a subcontractor: 100% goal credit for the work of the subcontract performed by the DBE's own forces, including the cost of materials and supplies. Work that a DBE subcontractor in turn subcontracts to a non-DBE firm does not count toward the DBE goal.

D. DBE as a trucker: 100% goal credit for trucking participation provided the DBE is responsible for the management and supervision of the entire trucking operation for which it is responsible. At least one truck owned, operated, licensed and insured by the DBE must be used on the contract. Credit will be given for the full value of all such DBE trucks operated using DBE employed drivers. Goal credit will be limited to the value of the reasonable fee or commission received by the DBE if trucks are leased from a non-DBE company.

E. DBE as a material supplier:

1. 60% goal credit for the cost of the materials or supplies purchased from a DBE regular dealer.
2. 100% goal credit for the cost of materials or supplies obtained from a DBE manufacturer.
3. 100% credit for the value of reasonable fees and commissions for the procurement of materials and supplies if not a regular dealer or manufacturer.

VIII. GOOD FAITH EFFORT PROCEDURES: If the bidder cannot obtain sufficient DBE commitments to meet the contract goal, the bidder must document in the Utilization Plan the good faith efforts made in the attempt to meet the goal. This means that the bidder must show that all necessary and reasonable steps were taken to achieve the contract goal. Necessary and reasonable steps are those which could reasonably be expected to obtain sufficient DBE participation. The Department will consider the quality, quantity and intensity of the kinds of efforts that the bidder has made. Mere *pro forma* efforts are not good faith efforts; rather, the bidder is expected to have taken those efforts that would be reasonably expected of a bidder actively and aggressively trying to obtain DBE participation sufficient to meet the contract goal.

- A. The following is a list of types of action that the Department will consider as part of the evaluation of the bidder's good faith efforts to obtain participation. These listed factors are not intended to be a mandatory checklist and are not intended to be exhaustive. Other factors or efforts brought to the attention of the Department may be relevant in appropriate cases, and will be considered by the Department.
1. Soliciting through all reasonable and available means (e.g. attendance at pre-bid meetings, advertising and/or written notices) the interest of all certified DBE companies that have the capability to perform the work of the contract. The bidder must solicit this interest within sufficient time to allow the DBE companies to respond to the solicitation. The bidder must determine with certainty if the DBE companies are interested by taking appropriate steps to follow up initial solicitations.
 2. Selecting portions of the work to be performed by DBE companies in order to increase the likelihood that the DBE goals will be achieved. This includes, where appropriate, breaking out contract work items into economically feasible units to facilitate DBE participation, even when the prime contractor might otherwise prefer to perform these work items with its own forces.
 3. Providing interested DBE companies with adequate information about the plans, specifications, and requirements of the contract in a timely manner to assist them in responding to a solicitation.
 4. (a) Negotiating in good faith with interested DBE companies. It is the bidder's responsibility to make a portion of the work available to DBE subcontractors and suppliers and to select those portions of the work or material needs consistent with the available DBE subcontractors and suppliers, so as to facilitate DBE participation. Evidence of such negotiation includes the names, addresses, and telephone numbers of DBE companies that were considered; a description of the information provided regarding the plans and specifications for the work selected for subcontracting; and evidence as to why additional agreements could not be reached for DBE companies to perform the work.

(b) A bidder using good business judgment would consider a number of factors in negotiating with subcontractors, including DBE subcontractors, and would take a firm's price and capabilities as well as contract goals into consideration. However, the fact that there may be some additional costs involved in finding and using DBE companies is not in itself sufficient reason for a bidder's failure to meet the contract DBE goal, as long as such costs are reasonable. Also, the ability or desire of a prime contractor to perform the work of a contract with its own organization does not relieve the bidder of the responsibility to make good faith efforts. Prime contractors are not, however, required to accept higher quotes from DBE companies if the price difference is excessive or unreasonable.
 5. Not rejecting DBE companies as being unqualified without sound reasons based on a thorough investigation of their capabilities. The contractor's standing within its industry, membership in specific groups, organizations, or associations and political or social affiliations (for example union vs. non-union employee status) are not legitimate causes for the rejection or non-solicitation of bids in the contractor's efforts to meet the project goal.
 6. Making efforts to assist interested DBE companies in obtaining bonding, lines of credit, or insurance as required by the recipient or contractor.
 7. Making efforts to assist interested DBE companies in obtaining necessary equipment, supplies, materials, or related assistance or services.
 8. Effectively using the services of available minority/women community organizations; minority/women contractors' groups; local, state, and Federal minority/women business assistance offices; and other organizations as allowed on a case-by-case basis to provide assistance in the recruitment and placement of DBE companies.
- B. If the Department determines that the Contractor has made a good faith effort to secure the work commitment of DBE companies to meet the contract goal, the Department will award the contract provided that it is otherwise eligible for award. If the Department determines that a good faith effort has not been made, the Department will notify the bidder of that preliminary determination by contacting the responsible company official designated in the Utilization Plan. The preliminary determination shall include a statement of reasons why good faith efforts have not been found, and may include additional good faith efforts that the bidder could take. The notification will

designate a five (5) working day period during which the bidder shall take additional efforts. The bidder is not limited by a statement of additional efforts, but may take other action beyond any stated additional efforts in order to obtain additional DBE commitments. The bidder shall submit an amended Utilization Plan if additional DBE commitments to meet the contract goal are secured. If additional DBE commitments sufficient to meet the contract goal are not secured, the bidder shall report the final good faith efforts made in the time allotted. All additional efforts taken by the bidder will be considered as part of the bidder's good faith efforts. If the bidder is not able to meet the goal after taking additional efforts, the Department will make a pre-final determination of the good faith efforts of the bidder and will notify the designated responsible company official of the reasons for an adverse determination.

- C. The bidder may request administrative reconsideration of a pre-final determination adverse to the bidder within the five (5) working days after the notification date of the determination by delivering the request to the Department of Transportation, Division of Aeronautics, 1 Langhorne Bond Drive, Capital Airport, Springfield, IL 62707-8415 (Telefax: 217-785-4533). Deposit of the request in the United States mail on or before the fifth business day shall not be deemed delivery. The pre-final determination shall become final if a request is not made and delivered. A request may provide additional written documentation and/or argument concerning the issue of whether an adequate good faith effort was made to meet the contract goal. In addition, the request shall be considered a consent by the bidder to extend the time for award. The request will be forwarded to the Department's Reconsideration Officer. The Reconsideration Officer will extend an opportunity to the bidder to meet in person in order to consider all issues of whether the bidder made a good faith effort to meet the goal. After the review by the Reconsideration Officer, the bidder will be sent a written decision within ten (10) working days after receipt of the request for reconsideration, explaining the basis for finding that the bidder did or did not meet the goal or make adequate good faith efforts to do so. A final decision by the Reconsideration Officer that a good faith effort was made shall approve the Utilization Plan submitted by the bidder and shall clear the contract for award. A final decision that a good faith effort was not made shall render the bid nonresponsive.

IX. CONTRACT COMPLIANCE: Compliance with this Special Provision is an essential part of the contract. The Department is prohibited by federal regulations from crediting the participation of a DBE included in the Utilization Plan toward either the contract goal or the Department's overall goal until the amount to be applied toward the goals has been paid to the DBE. The following administrative procedures and remedies govern the compliance by the Contractor with the contractual obligations established by the Utilization Plan. After approval of the Plan and award of the contract, the Utilization Plan and individual DBE Participation Statements become part of the contract. If the contractor did not succeed in obtaining enough DBE participation to achieve the advertised contract goal, and the Utilization Plan was approved and contract awarded based upon a determination of good faith, the total dollar value of DBE work calculated in the approved Utilization Plan as a percentage of the awarded contract value shall become the amended contract goal.

- A. No amendment to the Utilization Plan may be made without prior written approval from the Division of Aeronautics. All requests for amendment to the Utilization Plan shall be submitted to the Department of Transportation, Division of Aeronautics, 1 Langhorne Bond Drive, Capital Airport, Springfield, IL 62707-8415. Telephone number (217) 785-8514. Telefax number (217) 785-4533.
- B. All work indicated for performance by an approved DBE shall be performed, managed and supervised by the DBE executing the Participation Statement. The Contractor shall not terminate for convenience a DBE listed in the Utilization Plan and then perform the work of the terminated DBE with its own forces, those of an affiliate or those of another subcontractor, whether DBE or not, without first obtaining the written consent of the Bureau of Small Business Enterprises to amend the Utilization Plan. If a DBE listed in the Utilization Plan is terminated for reasons other than convenience, or fails to complete its work on the contract for any reason, the Contractor shall make good faith efforts to find another DBE to substitute for the terminated DBE. The good faith efforts shall be directed at finding another DBE to perform at least the same amount of work under the contract as the DBE that was terminated, but only to the extent needed to meet the contract goal or the amended contract goal. The Contractor shall notify the Division of Aeronautics of any termination for reasons other than convenience, and shall obtain approval for inclusion of the substitute DBE in the Utilization Plan. If good faith efforts following a termination of a DBE for cause are not successful, the Contractor shall contact the Division and provide a full accounting of the efforts undertaken to obtain substitute DBE participation. The Division will evaluate the good faith efforts in light of all circumstances surrounding the performance status of the contract, and determine whether the contract goal should be amended.

- C. The Contractor shall maintain a record of payments for work performed to the DBE participants. The records shall be made available to the Department for inspection upon request. After the performance of the final item of work or delivery of material by a DBE and final payment therefor to the DBE by the Contractor, but not later than thirty (30) calendar days after payment has been made by the Department to the Contractor for such work or material without regard to any retainage withheld by the Department, the Contractor shall submit a DBE Payment Report on Department form SBE 2115 to the Division's Chief Engineer. If full and final payment has not been made to the DBE, the Report shall indicate whether a disagreement as to the payment required exists between the Contractor and the DBE or if the Contractor believes that the work has not been satisfactorily completed. If the Contractor does not have the full amount of work indicated in the Utilization Plan performed by the DBE companies indicated in the Plan, the Department will deduct from contract payments to the Contractor the amount of the goal not achieved as liquidated and ascertained damages.

- D. The Department reserves the right to withhold payment to the Contractor to enforce the provisions of this Special Provision. Final payment shall not be made on the contract until such time as the Contractor submits sufficient documentation demonstrating achievement of the goal in accordance with this Special Provision or after liquidated damages have been determined and collected.

Certification of Nonsegregated Facilities - as Required by 41 CFR 60-1.8

(Applicable to (1) contracts, (2) subcontracts, and (3) agreements with applicants who are themselves performing federally assisted construction contracts, exceeding \$10,000.00 which are not exempt from the provisions of the Equal Opportunity clause).

By the submission of this bid, the bidder, offeror, applicant, or subcontractor certifies that he does not maintain or provide for his employees any segregated facilities at any of his establishments and that that he does not permit his employees to perform their services at any location, under his control, where segregated facilities are maintained. He certifies further that he will not maintain or provide for his employees any segregated facilities at any of his establishments and that he will not permit his employees to perform their services at any location, under his control, where segregated facilities are maintained. The bidder, offeror, applicant, or subcontractor agrees that a breach of his certification is a violation of the Equal opportunity clause in this contract. As used in this certification, the term "segregated facilities" means any waiting rooms, work areas, rest rooms and wash rooms, restaurants and other eating areas, time clocks, locker rooms and other storage or dressing areas, parking lots, drinking fountains, recreation or entertainment areas, transportation, and housing facilities provided for employees which are segregated by explicit directive or are in fact segregated on the basis of race, color, religion, or national origin, because of habit, local custom, or otherwise. He further agrees that (except where he has obtained identical certifications from proposed subcontractors for specific time periods) he will obtain identical certifications from proposed subcontractors prior to the award of subcontracts exceeding \$10,000.00 which are not exempt from the provisions of the Equal Opportunity clause; that he will retain such certifications in his files and that he will forward the following notice to such proposed subcontractors (except where the proposed subcontractors have submitted identical certifications for specific time periods):

NOTICE TO PROSPECTIVE SUBCONTRACTORS OF REQUIREMENT FOR
CERTIFICATIONS OF NONSEGREGATED FACILITIES

A certification of Nonsegregated Facilities must be submitted prior to the award of a subcontract exceeding \$10,000.00 which is not exempt from the provisions of the Equal Opportunity clause. The certification may be submitted either for each subcontract or for all subcontracts during a period (i.e., quarterly, semiannually or annually).

NOTE: The penalty for making false statements in offers is prescribed in 18 U.S.C 1001.

CERTIFICATION REGARDING DEBARMENT, SUSPENSION, AND OTHER RESPONSIBILITY MATTERS
Instructions for Certification

1. By signing and submitting this proposal, the prospective primary participant is providing the certification set out below.
2. The inability of a person to provide the certification required below will not necessarily result in denial of participation in this covered transaction. The prospective participant shall submit an explanation of why it cannot provide the certification set out below. The certification or explanation will be considered in connection with the department or agency's determination whether to enter into this transaction. However, failure of the prospective primary participant to furnish a certification or an explanation shall disqualify such person from participation in this transaction.
3. The certification in this clause is a material representation of fact upon which reliance was placed when the department or agency determined to enter into this transaction. If it is later determined that the prospective primary participant knowingly rendered an erroneous certification in addition to other remedies available to the Federal Government, the department or agency may terminate this transaction for cause of default.
4. The prospective primary participant shall provide immediate written notice to the department or agency to whom this proposal is submitted if at any time the prospective primary participant learns that its certification was erroneous when submitted or has become erroneous by reason of changed circumstances.
5. The terms "covered transaction" "debarred" "suspended" "ineligible" "lower tier covered transaction" "participant" "person" "primary covered transaction" "principal" "proposal" and "voluntarily excluded" as used in this clause have the meaning set out in the Definitions and Coverage sections of the rules implementing Executive Order 12540. You may contact the department or agency to which this proposal is being submitted for assistance in obtaining a copy of those regulations.
6. The prospective primary participant agrees by submitting this proposal that should the proposed covered transaction be entered into, it shall not knowingly enter into any lower tier covered transaction with a person who is debarred, suspended, declared ineligible, or voluntarily excluded from participation in this covered transaction unless authorized by the department or agency entering into this transaction.
7. The prospective primary participant further agrees by submitting this proposal that it will include the clause titled "Certification Regarding Debarment, Suspension, Ineligibility and Voluntary Exclusion - Lower Tier Transaction", provided by the department or agency entering into this covered transaction without modification in all lower covered transactions and in all solicitations for lower covered transactions.
8. A participant in a covered transaction may rely upon a certification of a prospective participant in a lower tier covered transaction that it is not debarred, suspended, ineligible, or voluntarily excluded from the covered transaction unless it knows that the certification is erroneous. A participant may decide the method and frequency by which it determines the eligibility of its principals. Each participant may, but is not required to check the Nonprocurement List (Tel. #).
9. Nothing contained in the foregoing shall be construed to require establishment of a system of records in order to render in good faith the certification required by this clause. The knowledge and information of a participant is not required to exceed that which is normally possessed by a prudent person in the ordinary course of business dealings.
10. Except for transactions authorized under paragraph 8 of these instructions, if a participant in a covered transaction knowingly enters into a lower tier covered transaction with a person who is suspended, debarred, ineligible, or voluntarily excluded from participation in this transaction, in addition to other remedies available to the Federal Government, the department or agency may terminate this transaction for cause or default.

Certification Regarding Debarment, Suspension, and
Other Responsibility Matters - Primary Covered Transactions

1. The prospective primary participant certifies to the best of its knowledge and belief that it and its principals:
 - a. Are not presently debarred, suspended, proposed for debarment, declared ineligible, or voluntarily excluded from covered transactions by an Federal department or agency;
 - b. Have not within a three-year period preceding this proposal been convicted of or had a civil judgment rendered against them for commission of fraud or a criminal offense in connection with obtaining, attempting to obtain or performing a public (Federal, State or Local) transaction or contract under a public transaction: violation of Federal or State antitrust statutes or commission of embezzlement, theft, forgery, bribery, falsification or destruction or destruction of records, making false statements, or receiving stolen property;
 - c. Are not presently indicted for or otherwise criminally or civilly charged by a governmental entity (Federal, State or local) with commission of any of the offenses enumerated in paragraph (1)(b) of this certification; and
 - d. Have not within a three-period preceding this application/proposal had one or more public transactions (Federal, State or local) terminated for cause or default.
2. Where the prospective primary participant is unable to certify to any of the statements in this certification, such prospective participant shall attach an explanation to this proposal.

CERTIFICATION REGARDING LOBBYING (Applicable to contracts in excess of \$100,000):

Certification for Contracts, Grants, Loans and Cooperative Agreements.

The undersigned bidder certifies, to the best of his or her knowledge and belief, that:

- (1) No Federal appropriated funds have paid or will be paid, by or behalf of the undersigned, to any person for influencing or attempting to influence an officer or employee of any agency, a Member of Congress, an Officer or employee of Congress, or an employee of a Member of Congress in connection with the awarding of any Federal contract, the making of any Federal grant, the making of any Federal loan, the entering into of any cooperative agreement, and the extension, continuation, renewal, amendment, or modification of any Federal contract, grant, loan, or cooperative agreement.
- (2) If any funds other than Federal appropriated funds have been paid or will be paid to any person for influencing or attempting to influence an officer or employee of any agency, a Member of Congress, an officer or employee of Congress, or an employee of a Member of Congress in connection with this Federal contract, grant, loan, or cooperative agreement, the undersigned shall complete and submit Standard Form-LLL, "Disclosure Form to Report Lobbying", in accordance with its instructions.
- (3) The undersigned shall require that the language of this certification be included in the award documents for all subawards at all tiers (including subcontracts, subgrants, and contracts under grants, loans, and cooperative agreements) and that all subrecipients shall certify and disclose accordingly.

This certification is a material representation of fact upon which reliance was placed when this transaction was made or entered into. Submission of this certification is a prerequisite for making or entering into this transaction imposed by Section 1352, title 31, U.S. Code. Any person who fails to file the required certification shall be subject to a civil penalty of not less than \$10,000 and not more than \$100,000 for each such failure.

WORKERS' COMPENSATION INSURANCE

Prior to the execution of his construction contract by the Illinois Department of Transportation, Division of Aeronautics, hereinafter referred to as "Division", the Contractor shall furnish to the Division certificates of insurance covering Workers' Compensation, or satisfactory evidence that this liability is otherwise taken care of in accordance with Section 4.(a) of the "Workers' Compensation Act of the State of Illinois" as amended.

Such insurance, or other means of protection as herein provided, shall be kept in force until all work to be performed under the terms of the contract has been completed and accepted in accordance with the specifications, and it is hereby understood and agreed that the maintenance of such insurance or other protection, until acceptance of the work by the Division is a part of the contract. Failure to maintain such insurance, cancellation by the Industrial Commission of its approval of such other means of protection as might have been elected, or any other act which results in lack of protection under the said "Workers' Compensation Act" may be considered as a breach of the contract.

SPECIAL PROVISION FOR DOMESTIC SOURCE FOR STEEL

Control of Materials: All steel products, as defined by the Illinois Steel Products Procurement Act, incorporated into this project shall be manufactured or produced in the United States and, in addition, shall be domestically fabricated. The Contractor shall obtain from the steel producer and/or fabricator, in addition to the mill analysis, a certification that all steel products meet these domestic source requirements.

CLAUSE TO BE INCLUDED IN ALL SOLICITATIONS,
CONTRACTS, AND SUBCONTRACTS RESULTING FROM PROJECTS FUNDED UNDER THE AIP

The Contractor or subcontractor, by submission of an offer and/or execution of a contract, certifies that it:

- a. is not owned or controlled by one or more citizens or nationals of a foreign country included in the list of countries that discriminate against U.S. firms published by the Office of the United States Trade Representative (USTR);
- b. has not knowingly entered into any contract or subcontract for this project with a Contractor that is a citizen or national of a foreign country on said list, or is owned or controlled directly or indirectly by one or more citizens or nationals of a foreign country on said list.
- c. has not procured any product nor subcontracted for the supply of any product for use on the project that is produced in a foreign country on said list.

Unless the restrictions of this clause are waived by the Secretary of Transportation in accordance with 49 CFR 30.17, no contract shall be awarded to a Contractor or subcontractor who is unable to certify to the above. If the Contractor knowingly procures or subcontracts for the supply of any product or service of a foreign country on the said list for use on the project, the Federal Aviation Administration may direct, through the sponsor, cancellation of the contract at no cost to the Government.

Further, the Contractor agrees that, if awarded a contract resulting from this solicitation, it will incorporate this provision for certification without modification in each contract and in all lower tier subcontracts. The Contractor may rely upon the certification of a prospective subcontractor unless it has knowledge that the certification is erroneous.

The Contractor shall provide immediate written notice to the sponsor if the Contractor learns that its certification or that of a subcontractor was erroneous when submitted or has become erroneous by reason of changed circumstances. The subcontractor agrees to provide immediate written notice to the Contractor, if at any time it learns that its certification was erroneous by reason of changed circumstances.

This certification is a material representation of fact upon which reliance was placed when making the award. If it is later determined that the Contractor or subcontractor knowingly rendered an erroneous certification, the Federal Aviation Administration may direct, through this sponsor, cancellation of the contract or subcontract for default at no cost to the Government.

Nothing contained in the foregoing shall be construed to require establishment of a system of records in order to render, in good faith, the certification required by this provision. The knowledge and information of a Contractor is not required to exceed that which is normally possessed by a prudent person in the ordinary course of business dealings.

This certification concerns a matter within the jurisdiction of an agency of the United States of America and the making of false, fictitious, or fraudulent certification may render the maker subject to prosecution under Title 18, United States Code, Section 1001.

SECTION III

Special Provisions

For

**CONSTRUCT RUNWAY 33 INSTRUMENT LANDING SYSTEM;
RELOCATE RUNWAY 9 LOCALIZER**

**ILLINOIS PROJECT: ARR-3468
A.I.P. PROJECT: 3-17-0003-B31**

At

**AURORA MUNICIPAL AIRPORT
AURORA, ILLINOIS**

March 3, 2006

Prepared By:

CRAWFORD, MURPHY & TILLY, INC.
CONSULTING ENGINEERS
600 NORTH COMMONS DRIVE, SUITE 107
AURORA, ILLINOIS 60504
<http://www.cmtengr.com>

04285-04-00

3-16-06
EXP. 11-30-07

GENERAL

These Special Provisions, together with applicable Standard Specifications, Rules and Regulations, Contract Requirements for Airport Improvement Projects, Payroll Requirements and Minimum Wage Rates which are hereto attached or which by reference are herein incorporated, cover the requirements of the State of Illinois, Department of Transportation, Division of Aeronautics for the construction of the subject project at the Aurora Municipal Airport, Aurora, Illinois.

GOVERNING SPECIFICATIONS AND RULES AND REGULATIONS

The "Standard Specifications for Construction of Airports", dated January 1985, State of Illinois Department of Transportation, Division of Aeronautics, and the "Supplemental Specifications and Recurring Special Provisions", dated July 1, 2004, State of Illinois Department of Transportation, Division of Aeronautics, indicated on the Check Sheet included herein shall govern the project except as otherwise noted in these Special Provisions. In cases of conflict with any part or parts of said specifications, the said Special Provisions shall take precedence and shall govern. As noted within the Special Provisions the Illinois Department of Transportation Standard Specifications for Road and Bridge Construction dated January 1, 2002 shall apply.

INDEX TO SPECIAL PROVISIONS

<u>ITEM - DESCRIPTION</u>	<u>PAGE NUMBER</u>
DIVISION I – GENERAL PROVISIONS	1
SECTION 10 – Definition Of Terms.....	1
SECTION 20 – Scope OF Work.....	1
SECTION 30 – Control Of Work.....	2
SECTION 40 – Control Of Materials.....	2
SECTION 50 – Legal Relations And Responsibility To Public.....	3
SECTION 60 – Prosecution And Progress.....	3
DIVISION II – PAVING CONSTRUCTION DETAILS	5
ITEM 151 – Clearing and Grubbing.....	5
ITEM 152 – Excavation and Embankment.....	6
ITEM 209 – Crushed Aggregate Base Course.....	7
ITEM 401001 – Bituminous Surface Course - Method 1.....	8
ITEM 610 – Structural Portland Cement Concrete.....	9
ITEM 620 – Pavement Marking.....	9
DIVISION III – FENCING	10
ITEM 162 – Chain Link Fences.....	10
DIVISION IV – DRAINAGE PIPE	15
ITEM 701 – Pipe For Storm Sewers and Culverts.....	15
ITEM 705 – Pipe Underdrains For Airports.....	15
ITEM 752 – Concrete Culverts, Headwalls and Misc. Drainage Structures.....	16
DIVISION V – TURFING	17
ITEM 901 – Seeding.....	17
ITEM 908 – Mulching.....	19

DIVISION VI – LIGHTING INSTALLATION	20
ITEM 108 – Installation Of Underground Cable.....	20
ITEM 110 – Installation Of Airport Underground Electrical Duct.....	23
ITEM 125 – Installation Of Airport Lighting Systems	24
DIVISION VIII – MISCELLANEOUS	30
ITEM 150510 – Engineer's Field Office	30
ITEM 127 – Airport NAVAID Installation	30
ITEM 127430 – Shelter Building	39
ITEM 127903 – Remove Shelter Building.....	42
ITEM 800101 – Delineator	43
ITEM 800119 – Remove Gravel	44
ITEM 800123 – Cable Barrier Gate	44
ITEM 800145 – Localizer Ground Check Point	45
ITEM 910420 – Bollard	47

RECURRING SPECIAL PROVISIONS

The following RECURRING SPECIAL PROVISIONS indicated by an "X" are Applicable to this contract and are included by reference:

<u>Check Sheet No.</u>	<u>Item No.</u>		<u>Page No.</u>
1	AR101580	Refurbish 36" Beacon	155
2	AR106000	Apron Lighting	160
3	AR119000	Airport Obstruction Lighting (Not Included)	166
4	AR127000	Airport Navaid Installation (Not Included)	167
5 X	AR150510	Engineer's Field Office	168
6	AR150560	Temporary Threshold	170
7	AR152540	Soil Stabilization Fabric	173
8 X	AR156000	Erosion Control	175
9 X	AR156513	Separation Fabric	180
10	AR156540	Riprap	182
11	AR201001	Bituminous Base Course -Method I	185
12	AR201002	Bituminous Base Course -Method II	193
13	AR201003	Bituminous Base Course – Method I, Superpave	209
14	AR201004	Bituminous Base Course – Method II, Superpave	217
15	AR201661	Clean & Seal Bituminous Cracks	230
16	AR201663	Sand Mix Crack Repair	233
17	AR201671	Crack Control Fabric	235
18	AR302000	Asphalt Treated Permeable Subbase	237
19 X	AR401001	Bituminous Surface Course -Method I	245
20	AR401002	Bituminous Surface Course -Method II	253
21	AR401003	Bituminous Surface Course – Method I, Superpave	269
22	AR401004	Bituminous Surface Course – Method II, Superpave	277
23	AR401640	Bituminous Pavement Grooving	290
24	AR401650	Bituminous Pavement Milling	293
25	AR401655	Butt Joint Construction	295
26	AR401900	Remove Bituminous Pavement	297
27	AR501001	Portland Cement Concrete -Pavement Method I	299
28	AR501002	Portland Cement Concrete -Pavement Method II	316
29	AR501003	Portland Cement Concrete -Pavement Method III	338
30	AR501115	Crack and Seat Pavement	362
31	AR501540	PCC Pavement Grooving	365
32	AR501550	PCC Pavement Milling	368
33	AR501900	Remove PCC Pavement	370
34	AR510500	Tie-down/Ground Rod	372
35	AR605000	Silicone Joint Sealing Filler	373

IDA POLICY MEMORANDUMS

- 87-2 DENSITY ACCEPTANCE OF BITUMINOUS PAVEMENTS
- 87-4 DETERMINATION OF BULK SPECIFIC GRAVITY (d) OF COMPACTED BITUMINOUS MIXES
- 96-1 ITEM 610, STRUCTURAL PORTLAND CEMENT CONCRETE: JOB MIX FORMULA APPROVAL & PRODUCTION TESTING
- 96-2 REQUIREMENTS FOR LABORATORY, TESTING, QUALITY CONTROL, AND PAVING OF BITUMINOUS CONCRETE MIXTURES
- 96-3 REQUIREMENTS FOR QUALITY ASSURANCE ON PROJECTS WITH BITUMINOUS CONCRETE PAVING
- 97-2 PAVEMENT MARKING PAINT ACCEPTANCE

IDOT STANDARD DRAWINGS

- 542401 Metal End Section for Pipe Culverts
- 635001 Delineator
- 664001-01 Chain Link Fence
- 720011 Metal Posts for Signs, Markers and Delineators

APPENDIX A

FAA SPECIFICATIONS

FAA- SPECIAL SPECIFICATION

- FAA-GL-918C SPECIFICATION FOR CONSTRUCTION OF TERMINAL NAVIGATIONAL FACILITIES

SPECIFICATIONS SUPPLEMENTAL TO SPECIFICATIONS FAA-GL-840b AND FAA-GL-918C

- FAA-STD-019e LIGHTNING AND SURGE PROTECTION, GROUNDING BONDING AND SHIELDING REQUIREMENTS FOR FACILITIES AND ELECTRONIC EQUIPMENT

DIVISION I – GENERAL PROVISIONS

SECTION 10 – DEFINITION OF TERMS

10-23 ENGINEER

DELETE:
Paragraph (b).

SECTION 20 – SCOPE OF WORK

20-05 MAINTENANCE OF TRAFFIC

ADD:

The Contractor shall be responsible for cleaning and maintaining all haul roads and use a pick-up type sweeper on all pavements and adjacent roadways utilized in hauling operations when material is tracked onto said pavement. **The Contractor shall have a sweeper on site and maintain all pavements clear of dirt and debris at all times or as requested by the Resident Engineer.** If the Contractor fails to comply with the Standard Specifications, contract plans or these Special Provisions concerning traffic control, the Engineer shall execute such work as may be deemed necessary to correct deficiencies and the cost thereof shall be deducted from compensation due or which may become due the Contractor under the contract. The Contractor shall be responsible for supplying, maintaining and moving all barricades required for construction. The cost thereof shall not be paid for separately but shall be considered incidental to the contract unit prices.

20-09 AIRPORT OPERATIONS DURING CONSTRUCTION

a. Construction Activity and Aircraft Movements

For construction activity to be performed in other areas than active operational areas, the storage and parking of equipment and materials, when not in use or about to be installed, shall not encroach upon active operational areas. In protecting operational areas, the minimum clearances maintained for runways shall be in conformance with Part 77 of the Federal Aviation Regulations.

All construction operations shall conform to the plans and in accordance with AC 150/5370-2 (Latest Edition) Operational Safety on Airports During Construction.

b. Limitations On Construction

- (1) Open flame welding or torch cutting operations shall be prohibited, unless adequate fire and safety precautions are provided.
- (2) Open trenches, excavations and stockpiled material near any pavements shall be prominently marked with red flags and lighted by light units during hours of restricted visibility and/or darkness.
- (3) Stockpiled material shall be constrained in a manner to prevent movement resulting from aircraft blast or wind conditions.
- (4) The use of explosives shall be prohibited.
- (5) Burning shall not be allowed.

c. Debris

Waste and loose material capable of causing damage to aircraft landing gears, propellers, or being ingested in jet engines shall not be placed on active aircraft movement areas. Material tracked on these areas shall be removed continuously during the work project. The Contractor shall provide garbage cans in employee parking areas and storage areas for debris.

20-10 EXCAVATION/DEWATERING

The Contractor shall, at all times, provide and maintain in operation pumping and/or well point equipment for the complete dewatering of the excavation. No structure or pipe shall be permitted to be constructed in an excavated area in which any amount of water flows or is pooled. The Contractor shall design, furnish, install, test, maintain and remove any required excavation support system to maintain the excavation. The cost of excavation support system and dewatering shall be included in the unit price of the associated pay item and not paid for separately.

20-1 LINE ITEM PROPERTY LIST

The Contractor shall provide to the Aurora Municipal Airport a line item property listing in tabular format, consisting of all real and personal property that will be included in the Project. Real property shall be identified by each line item and cost (i.e. foundation size, building type and dimensions, systems, composition of access road and parking, linear feet of fencing and cabling.) Personal property listing shall include the bar code number (where applicable), manufacturer, full item description, part number and/or serial number, quantity, model number, cost, funding appropriation, etc. The cost data for each item shall be supported by a copy of the original invoice or billing statement and a copy of the construction contract along with verification of the contract acceptance date.

The cost of the Contractor providing the line item property list shall not be paid for separately, but shall be considered incidental to the respective pay item associated with.

SECTION 30 – CONTROL OF WORK

30-18 PLANS AND WORK DRAWINGS

DELETE:

References to "approval" in first paragraph and replace with "review".

ADD: Revise references to the number of shop drawings to the following:

The Contractor shall submit at least twelve (12) copies of each shop drawing to be reviewed, of which ten (10) copies will be retained by the Project Engineer for his use and records. Two (2) copies of each drawing will be returned to the Contractor.

SECTION 40 – CONTROL OF MATERIALS

40-01 SOURCE OF SUPPLY AND QUALITY REQUIREMENTS

ADD: After the last paragraph

The Contractor shall certify all materials contained in the contract. Certification documentation shall be submitted to the Engineer. It shall be the sole responsibility of the Contractor to ensure the delivery of adequate and accurate documentation prior to the delivery of the materials.

If, upon delivery and incorporation of any materials, the Contractor has failed to provide the necessary submittals as required by Sections 30-18, 40-01, 40-03 and 40-11 of the Standard and Special Provisions,

the pay item shall not included on the Construction Progress Payment report until such submittals have been furnished.

SECTION 50 – LEGAL RELATIONS AND RESPONSIBILITY TO PUBLIC

50-17 CONTRACTOR'S RESPONSIBILITY FOR UTILITY SERVICE AND FACILITIES OF OTHERS

ADD:

Special care shall be taken on all operations and particularly near pavement edges to avoid damage to edge lights and all underground electrical cable on the airport. Any airfield lights or cable that are broken and require replacement because of the Contractor's operations will be replaced by the contractor at his own expense.

Any airfield cable repairs or replacement to any part of the electrical system made necessary by the Contractor's operations will be made by him at no cost to the airport. Cost of replacement to be borne by the Contractor shall include any expense incurred in locating as well as repairing or replacing damaged parts of the system by the owning agency.

It shall be the Contractor's responsibility to locate and protect all airport-owned utilities within the construction limits. This includes but is not limited to all electrical cables, storm sewer, drain tile, sanitary sewer and water main.

Should any utilities or cables require location, the following people shall be contacted:

AURORA MUNICIPAL AIRPORT

Utility Service or Facility	Person to Contact	Contact Phone
FAA Control & Communications Cable	FAA Sector Field Office	1-630-587-7801
Comed - Electric Cables	JULIE	1-800-892-0123
SBC - Telephone Cables	JULIE	1-800-892-0123
NICOR - Gas Lines	JULIE	1-800-892-0123
Village of Sugar Grove & City of Aurora – Watermain	JULIE	1-800-892-0123

SECTION 60 – PROSECUTION AND PROGRESS

60-05 LIMITATION OF OPERATIONS

ADD:

The Contractor shall not have access to any part of the active airfield (runways or taxiways) for any equipment or personnel without approval of the Airport Director.

60-07 TEMPORARY SUSPENSION OF THE WORK

Replace references to "Resident Engineer" with "Engineer" throughout this section.

60-10 DEFAULT AND TERMINATION OF CONTRACT

Replace references to "Project Engineer" with "Engineer" throughout this section.

DIVISION II – PAVING CONSTRUCTION DETAILS

ITEM 151 – Clearing and Grubbing

(SUPPLEMENTAL SPECIFICATION)

DESCRIPTION

151-1.1

ADD:

This item shall also consist of the complete clearing and grubbing of trees with butt diameters greater than 6".

CONSTRUCTION METHODS

151-2.1 GENERAL

REVISE the Supplemental to: Burning shall not be allowed at the Airport.

151-2.2 CLEARING

REVISE the cut height to the following:

The trees, stumps and brush shall be cut to ground level.

151-2.3 CLEARING AND GRUBBING

ADD:

The clearing and grubbing of trees with trunk diameters of less than 6-inches shall be considered incidental to tree clearing and grubbing and clearing.

151-2.12

ADD:

The Contractor shall offer to turn over any timber pieces resulting from the tree clearing operation to the Airport. If the Airport chooses to retain possession of any timber pieces, the Contractor shall haul the timber to a site on Airport property designated by the Airport Director. If the Airport chooses not to retain possession of any timber pieces, the Contractor shall dispose of all materials off Airport property. Any hauling or disposal costs shall not be paid for separately, but shall be considered incidental to tree clearing and grubbing.

METHOD OF MEASUREMENT

151-3.1

DELETE from Standard Specifications: The second paragraph and the schedule of sizes.

ADD:

The quantities for tree clearing and grubbing, as shown by the limits on the plans or as directed by the Engineer, shall be measured in inch diameter, measured at a point 12 inches above ground level at each tree. Tree clearing and grubbing shall be paid for according to the schedule of sizes as follows:

Total Inches in Diameter of Trees:

Tree Clearing and Grubbing (6"-15") – inch diameter

Tree Clearing and Grubbing (+ 15") – inch diameter

The clearing of brush and trees with a butt diameter less than 6 inches will not be measured for payment separately, but shall be included in the unit price for clearing per acre.

All refuse within the project limits and fence removal within the project limits shall be removed and disposed of off airport property at no additional cost to the contract.

BASIS OF PAYMENT

151-4.1

DELETE from Supplemental: This section.

ADD:

Payment shall be made at the contract unit price per acre for clearing and at the contract unit price per inch diameter for tree clearing and grubbing. This price shall be full compensation for furnishing all materials, and for all labor equipment, tools and incidentals necessary to complete this item.

Payment will be made under:

ITEM AR151410	CLEARING	PER ACRE.
ITEM AR800033	TREE CLEARING AND GRUBBING (6" – 15")	PER IN-DIA.
ITEM AR800034	TREE CLEARING AND GRUBBING (+15")	PER IN-DIA.

ITEM 152 – Excavation and Embankment

(SUPPLEMENTAL SPECIFICATION)

152-1.1

Revise the second sentence of second paragraph of the Supplemental Specification to read:

All associated labor, equipment, materials and incidentals associated with obtaining the Proctor information is considered incidental to the respective pay item.

152-1.2 CLASSIFICATION

DELETE from Supplemental: The 4th paragraph – "Shoulder Adjustment".

CONSTRUCTION METHODS

152-2.2 EXCAVATION

ADD to Supplemental:

Excavation and embankment shall be compacted to a density of not less than the percentage of the maximum dry density, at optimum moisture, shown in Table 1 as determined by the compaction control tests cited in Division VII for ASTM D-698 (Standard Proctor) for aircraft weights under 60,000 pounds.

Shelter Building excavation and embankment areas shall be compacted to a density of not less than the 95 percent of the maximum dry density, at optimum moisture, shown in Table 1 as determined by the compaction control tests cited in Division VII for ASTM D-698 (Standard Proctor) for aircraft weights under 60,000 pounds.

METHOD OF MEASUREMENT

152-3.4

DELETE from Supplemental: This section.

BASIS OF PAYMENT

152-4.1

DELETE from Supplemental: The 3rd and 4th paragraphs in the Supplemental Specifications.

ADD to Supplemental:

Topsoil placement, shoulder fill and embankment fill shall not be paid for separately, but shall be included in the unit bid price for "UNCLASSIFIED EXCAVATION."

Payment will be made under:

ITEM AR152410 UNCLASSIFIED EXCAVATION PER CUBIC YARD.

ITEM 209 – CRUSHED AGGREGATE BASE COURSE

(SUPPLEMENTAL SPECIFICATION)

MATERIALS

209-2.3 GRADATION

DELETE: Gradation "C" in Table 1.

CONSTRUCTION METHODS

209-3.6 FINISHING AND COMPACTING

REVISE the percent compaction requirements to the following:

Structures, Slabs and Foundations:

The base shall be compacted to not less than 98% of maximum density at optimum moisture as determined by compaction control tests specified in Division VII for aircraft with gross weights of 60,000 lbs and less (Standard Proctor ASTM D698) or to the satisfaction of the Resident Engineer.

Access Roads/Parking Areas:

The base shall be compacted to not less than 95% of maximum density at optimum moisture as determined by compaction control tests specified in Division VII for aircraft with gross weights of 60,000 lbs and less (Standard Proctor ASTM D698) or to the satisfaction of the Resident Engineer.

Walkways in Turf and Non-Vehicular Surfaced (unpaved) Areas:

The base shall be compacted to not less than 90% of maximum density at optimum moisture as determined by compaction control tests specified in Division VII for aircraft with gross weights of 60,000 lbs and less (Standard Proctor ASTM D698) or to the satisfaction of the Resident Engineer.

The Contractor shall submit copies of all density test results for each lift to the Engineer prior to acceptance testing.

209-3.8 THICKNESS CONTROL

DELETE this section

BASIS OF PAYMENT

209-5.1

Payment will be made under:

ITEM AR209606	CRUSHED AGG. BASE COURSE – 6”	PER SQUARE YARD.
ITEM AR209608	CRUSHED AGG. BASE COURSE – 8”	PER SQUARE YARD.

ITEM 401001 – BITUMINOUS SURFACE COURSE - METHOD 1

CHECK SHEET NO. 19

MATERIALS

401-3.2 JOB MIX FORMULA (JMF)

Revise Table 2 to read as follows:

TABLE 2 MARSHALL DESIGN CRITERIA

	<u>UNDER 60,000 lb.</u>
Number of Blows	50
Stability (Min.)	1500
Flow	8-18
Percent Air Void	1.5-3.5
Voids Filled With Asphalt (%)	75 - 90

CONSTRUCTION METHODS

401-4.11 JOINTS

Add the following paragraph to this section:

At any time during the surface course paving operation it becomes necessary to end a paving lane at a location other than the proposed finished pavement edge because of ending a days paving, machinery breakdown, etc.; the lane end will be sawed back a sufficient distance to provide a smooth, neat appearing joint from which to resume paving. The sawed face will be painted with a tack coat and this work shall be considered incidental to Item 401 Bituminous Surface Course, and no additional compensation will be allowed.

401-4.12 SHAPING EDGES

ADD:

All pavement edges, including the pavement ends, must be left in proper alignment as shown on the plans. This may be accomplished by a trimming method or at the Contractor's option by sawing after the paving has been completed. No additional compensation will be made if the sawing method is used.

METHOD OF MEASUREMENT

401-5.1

ADD:

Measurement for payment will not be made for any bituminous surface course in excess of 103 percent of the quantity specified by the Engineer.

BASIS OF PAYMENT

401-6.1

Payment will be made under:

ITEM AR401610 BITUMINOUS SURFACE COURSE PER TON.

ITEM 610 – STRUCTURAL PORTLAND CEMENT CONCRETE

(SUPPLEMENTAL SPECIFICATION)

CONSTRUCTION METHODS

610-3.2 CONCRETE PROPORTIONS

Replace the last sentence of the sixth paragraph of Standard Specifications with "The air content of the concrete shall be between 5% and 8%, by volume."

ITEM 620 – PAVEMENT MARKING

(SUPPLEMENTAL SPECIFICATION)

METHOD OF MEASUREMENT

620-4.1

ADD to Supplemental:

The quantity of permanent markings to be paid for shall be the number of square feet of painting with the specified material **measured only once to apply two coats** in conformance with the specifications and accepted by the Engineer. Quantities will not be distinguished between white and yellow colors of paint.

BASIS OF PAYMENT

620-5.1

Payment will be made under:

**ITEM AR620520 PAVEMENT MARKING - WATERBORNE PER SQUAR FOOT.
ITEM AR620525 PAVEMENT MARKING – BLACK BORDER PER SQUAR FOOT.**

DIVISION III – FENCING

ITEM 162 – CHAIN LINK FENCES

(SUPPLEMENTAL SPECIFICATION)

DESCRIPTION

162-1.1

This item shall include installation of a 16' electric gate as shown in the plans or as directed by the Resident Engineer. The electric gate system shall include the new 16' slide gate, electric gate driver, gooseneck stand, key pad, detector loops, new electric service, cable and conduit as shown on the plans and any items necessary to make it operational to the satisfaction of the Engineer.

MATERIALS

162-2.1 FABRIC

DELETE from Supplemental: This section and REPLACE with:

Rewrite paragraph (a) (1) as follows:

Change "AASHTO M181, Type I, Class B" to "AASHTO M181, Type I, Class D"

The chain link fence shall be zinc coated steel fabric.

162-2.2 BARBED WIRE

DELETE: Entire Section. Barbed wire is not required.

162-2.3 FENCE POSTS, POST TOPS AND EXTENSIONS, RAIL, GATES, BRACES, STRETCHER BARS AND CLIPS

ADD:

Line Posts. The line posts shall be Type A, Type B or roll formed per IDOT Standard 664001-01.

Terminal Posts (End, Corner, or Pull). The terminal post shall be Type A, Type B or roll formed per IDOT Standard 664001-01.

Gate Posts. The gate posts shall be Type A. Gate posts for the 16' vehicular gates shall have a nominal O.D. of 4" and weigh at least 7.58 pounds per foot.

Post Braces. Post braces shall be provided for each gate, corner, pull and end post and shall meet the requirements for top tails.

Post Tops. Post tops shall consist of ornamental tops provided with a hole suitable for through passage of the top rail. The post tops shall fit over the outside of the posts and shall exclude moisture from inside the posts.

Vehicular gates shall be aluminum cantilever slide gate, Edko or equal. System shall facilitate installation of a top-hung, enclosed track, internal roller type cantilever sliding gate system as per ASTM F 1184-88 Type II, Class 2. Class 1 gates, i.e. designs using external rollers or other support systems, shall not be

acceptable. All forms of measurements contained herein are furnished to establish minimum acceptable standards.

Gate frame shall be fabricated from minimum 2" square 6061-T6 structural-grade aluminum alloy tubing weighing a minimum of 1.1 pounds per foot. Frame shall be welded at all corners so as to form a rigid unit. Gate shall be fabricated as a single welded unit with Uniweld construction. Intermediate vertical members shall be 2" X 2" 6061-T6 structural-grade aluminum alloy, weighing a minimum of 1.1 pounds per lineal foot. Intermediate verticals shall be spaced apart no more than 6'0" on center, and all vertical members gusseted at top and bottom for greater frame strength and rigidity. Enclosed track shall be a one-piece extrusion of 6061-T6 structural-grade aluminum alloy, weighing a minimum of 3.95 pounds per foot. Track shall be formed to enclose the internal-roller truck assemblies and structurally adequate to serve as the load-bearing surface for the gate panel. Reaction load rating of the track shall be a minimum of 2,000 pounds. Gate frame shall employ bi-directional cross bracing of 3/16" diameter stainless steel preformed aircraft cable, or diagonal tubular aluminum, installed in the vertical plane throughout the gate proper and the counterbalance to allow for vertical chord adjustment, and to add further rigidity to the gate.

Internal-roller truck assembly shall be self-aligning, swivel ball-and-socket type running on four bearing-wheels. Bearing-wheels shall be a minimum 2" diameter x 9/16" wide, rated as medium duty, with a basic dynamic load rating of 2,750 pounds per bearing. Truck body shall be a one-piece structural grade 356-T6 aluminum alloy casting, equipped with milled steel guide wheels to ensure lateral alignment within the track. Guide wheel axle shall extend through the top and bottom of the truck body so as to assure that, regardless of wear, the guide wheels cannot come loose from the axle and lodge in the track. Internal-roller truck assembly shall be affixed to the hanger bracket or other mounting fixture by means of a 5/8" diameter industrial-grade rod end/center bolt, with a maximum static load rating of 10,000 pounds. Attachment of the center bolt to the truck body shall be by means of a swivel joint to ensure equivalent and consistent loading on all bearing-wheels and internal track surfaces throughout the travel of the gate. Internal-roller truck assembly shall have the same reaction load as the enclosed track.

Bottom guide assembly shall consist of a steel mounting bracket with two 3" diameter phenolic roller wheels with sealed roller bearings mounted in such a way as to limit or contain gate lateral movement without binding. Roller wheels shall be braced top and bottom by the essential construction of the bottom guide in such a fashion as to prevent lateral gate movement which could deform the axles of the wheels and defeat the bottom guide assembly. Hanger assembly shall consist of minimum 3/8" thick steel plate, gusseted, which is to be affixed to a 4" O.D. post by means of 1/2" diameter U-bolts. All mounting hardware shall be hot-dip galvanized or plated for corrosion resistance.

Enclosed track shall be attached as per manufacturer's instructions to the gate frame provided by others. Completed gate assembly shall be erected on two 4" O.D. posts of schedule 40 galvanized steel pipe weighing a minimum of 9.1 pounds per foot.

Gate frames shall be painted to match the fence color. Prior to painting, prepare surface by roughening the surface with machine or hand sanders. Prime Coat to be Series 66, 2-3 dry mils and topcoat to be Series 73, 2-3 dry mils. Paint to be Tnemec or equal.

Gate fabric shall be the same type as used in the fence construction. The fabric shall be attached securely to the gate frame at intervals not exceeding 15 inches.

Gate hinges shall be of adequate strength for the gate with large bearing surfaces for clamping in position. The hinges shall not twist or turn under the action of the gate. The gates shall be capable of being opened and closed easily by one person.

Gate latches, stops and keepers shall be provided for the gates. Latches shall have a plunger bar arranged to engage the center stop. Latches shall be arranged for locking. Center stops shall consist of

a device arranged to be set in concrete and to engage a plunger bar of the latch of double gates. Keepers shall consist of a mechanical device for securing the free end of the gate when in the full open position.

All sliding vehicular gates shall have fully enclosed truck assembly glides, Edko or equal.

162-2.4 WIRE TIES AND TENSION WIRE

ADD:

Coiled spring tension wire of at least 7 gage O.D. steel wire shall be stretched along the bottom and top of the fence and securely fastened to the fabric with hog rings at 2-foot intervals.

162-2.9 ELECTRIC GATE DRIVE

ADD:

The Electrical Gate Drive System shall consist of the following:

- One chain driven gate operator
- One time delay
- Inherent and external obstruction sensing equipment
- One Keypad mounted on gooseneck stand
- New electric service
- Utility meter and disconnect mounted on unitstrut
- Weatherproof GFCI 120V receptacle
- 600V, 2-pole NEMA 3R Disconnect
- Concrete foundation for gate driver
- Concrete foundation for gooseneck stand
- Concrete foundation for electric meter and disconnect
- 1 ½' GRS conduit pushed, trenched and utility pole riser
- Secondary power cables, key pad and detector loop cables
- Vehicular Barriers
- Two detector loops (Inside & Outside Safety Loops and Inside Free Exit Loop)
- Radio controller with transmitters

GATE DRIVER

The proposed gate operator shall be B & B chain driven type. It shall be designed for heavy duty industrial operations handling 25 cycles per hour and for gates up to 70' in length and 1700 pounds in weight. Primary power for the operator shall be 230VAC single phase. The motor shall be enclosed in a NEMA 12 oil tight, weatherproof lockable enclosure. The system shall include a high starting torque, continuous duty, industrial motor with overload protection, driven limit switches and solenoid activated brake and shall be rated for 1 HP at 240V, single phase. Gate travel speed shall be a minimum of 12" per second. Gate operator shall be capable of operating with remote openers. Unit shall also have an enclosed power switch for convenience in maintenance and power train disconnect for manual operation. Gate driver shall be UL325 compliant and be manufactured with inherent and external obstruction sensing equipment. All electrical components shall be U.L. or C.S.A. listed.

The operator shall be controlled by (1) keypad, ten (10) remote openers and any other items and detailed on the plans or specified herein. It shall be the Contractor's responsibility to verify compatibility of all equipment with the gate driver.

ELECTRIC SERVICE INSTALLATION

The contractor shall install meter base and manual disconnect, mounted on unistrut or as shown

on the plans. Disconnect shall be rated 20A, 2 Pole with 20A, 2-Pole circuit breaker at 600VAC. Disconnect shall be as manufactured by Square D or equal. Coordinate all work with Commonwealth Edison. Install conduit and power cables between meter and the existing utility pole as shown on the plans.

CONVENIENCE RECEPTACLE

Contractor shall mount duplex, waterproof, GFCI receptacle on electric gate operator as directed by Engineer. All necessary hardware shall be incidental.

DIGITAL KEYPAD

New digital keypad shall be American Access Systems Model number Advantage DK ADV-50 or equal. The digital keypad shall be installed on the gooseneck stand as detailed on the plans or as recommended by the manufacturer. The proposed gooseneck stand shall be manufactured by American Access Systems Model # AAS-18-001 or equal.

DETECTOR LOOPS

Two detector loops shall be installed in the pavement as shown on the plans. One detector loop shall be installed in the pavement inside of the gate to allow for the free exit of vehicles leaving the Airfield as detailed in the plans and the safety of the vehicles entering the airport. The other detector loop shall be installed in the pavement outside the gate and shall be used as a safety loop that stops the gate from closing while a vehicle is still in its path.

ELECTRICAL WIRING

Electrical wiring shall consist of all wiring necessary to properly operate the motorized gate as recommended by the manufacturer or as directed by and to the satisfaction of the Engineer.

162-2.10 CERTIFICATION AND SHOP DRAWINGS

The Contractor shall provide written certification that all materials meet specification requirements prior to start of the work.

Shop drawings shall be submitted to the Engineer for review prior to the construction of fence and the gate. Shop drawings shall include exact layout, operation manual, etc. of the gate, truck glide assembly and all appurtenant items

162-2.11 SIGNS

The Contractor shall provide and install Restricted Area signage as shown on the plans. Sign panels shall be placed on all new fencing and the slide gates. The signs shall be placed at 100-foot intervals. One (1) will be placed on each slide gate. The sign shall be red letters on white background with a red border and shall read 'RESTRICTED/AREA/KEEP OUT' (three separate lines). The letters shall be a minimum of 2½" in height. The sign materials shall conform to Type 1 sign panels as specified in Section 720 of the IDOT Standard Specifications for Road and Bridge Construction.

BASIS OF PAYMENT

162-5.1

ADD:

Payment will be made at the contract unit price per each for the Gate Relocation. This price shall be full compensation for furnishing all materials and for all preparation, erection and removal and reinstallation of the existing gate and for all labor equipment, tools and incidentals necessary to complete this item.

The conduit and cable between key pad and gate driver, gooseneck stand, gate driver, key pad, disconnect, utility pole, meter base, receptacle and other miscellaneous items required to make a complete and operational system as detailed on the plans shall not be paid for separately but shall be incidental to the pay item "AR162716 ELECTRIC GATE – 16".

Sign panels as shown on the fencing details shall not be paid for separately but shall be incidental to the fence and gate.

Payment will be made under:

ITEM AR162506	CLASS E FENCE 6'	PER LINEAR FOOT.
ITEM AR162716	ELECTRIC GATE – 16'	PER EACH.
ITEM AR800127	RELOCATE GATE	PER EACH.

DIVISION IV – DRAINAGE PIPE

ITEM 701 – PIPE FOR STORM SEWERS AND CULVERTS

(SUPPLEMENTAL SPECIFICATION)

MATERIALS

701-2.1 GENERAL

DELETE: Entire Section.

ADD:

Pipe shall be of the type and diameter indicated and installed at the locations shown on the plans. Pipe for storm sewers shall be corrugated metal pipe conforming to ASTM A-760 per Section 542 of the Illinois Department of Transportation Standard Specifications for Road and Bridge Construction dated January 1, 2002 unless otherwise called out in the plans. All pipe shall be Type 1.

CONSTRUCTION METHODS

701-3.13 FARM FIELD TILES

ADD:

All farm field tiles encountered during the construction must be protected, replaced, or connected to the proposed storm sewers and culverts, as directed by the Engineer. Protection, replacement, and connection of farm field tiles will not be measured for payment, but shall be considered incidental to the associated item.

BASIS OF PAYMENT

701-5.1

ADD:

If, upon delivery and incorporation of any materials, the Contractor has failed to provide the necessary submittals as required by Sections 30-18, 40-01, 40-03 and 40-11 of the Standard and Special Provisions, the pay item shall not included on the Construction Progress Payment report until such submittals have been furnished.

ITEM AR701218	18" CMP	PER LINEAR FOOT.
ITEM AR701224	24" CMP	PER LINEAR FOOT.
ITEM AR701900	REMOVE PIPE	PER LINEAR FOOT.

ITEM 705 – PIPE UNDERDRAINS FOR AIRPORTS

CONSTRUCTION METHODS

705-3.9 UNDERDRAIN REMOVAL

This work shall consist of the removal of existing underdrain of various types and sizes. Trenches resulting from the removal shall be backfilled and compacted in accordance with P-152, Excavation and

Embankment for areas in proposed turf or backfilled and compacted in accordance with Section 701-2.7 and 701-3.7 for areas under proposed pavements. Underdrain shall be disposed of by the Contractor off Airport property.

Trench backfill of removal items shall be incidental to the removal item.

BASIS OF PAYMENT

705-5.1

ADD as the last sentence of the first paragraph of the Supplemental Specification:

Delete the fifth paragraph of the Supplemental Specification.

Payment will be made under:

ITEM AR705900 REMOVE UNDERDRAIN PER LINEAR FOOT.

**ITEM 752 – CONCRETE CULVERTS, HEADWALLS AND MISC. DRAINAGE
STRUCTURES**

(SUPPLEMENTAL SPECIFICATION)

DESCRIPTION

752-1.1

ADD:

Specifically, this item shall consist of the installation of metal end sections per IDOT Standard Detail 542401 and in accordance with these specifications at the locations shown in the plans.

BASIS OF PAYMENT

**ITEM AR752218 METAL END SECTION 18" PER EACH.
ITEM AR752224 METAL END SECTION 24" PER EACH.**

DIVISION V – TURFING

ITEM 901 – Seeding

(SUPPLEMENTAL SPECIFICATION)

MATERIALS

901-2.1 SEED

REVISE: The second sentence in the second paragraph in the Standard Specifications to read:

The contractor shall furnish the Resident Engineer duplicate signed copies of a statement by a recognized laboratory for seed testing within one year of the date of delivery.

DELETE: The seed mix table.

ADD:

The seed mixture shall be as follows:

SEEDING MIXTURE
SEEDING CLASS 1 – LAWN MIXTURES

<u>SEEDS</u>	<u>LBS/ACRE</u>
Kentucky Bluegrass	100
Perennial Ryegrass	60
Creeping Red Fescue	<u>40</u>
TOTAL	200

IDOT Class 4A and Class 4B shall meet Section 250.07 Seeding Mixtures of the IDOT Standard Specifications for Road and Bridge Construction.

Alternate seed mixtures may be submitted to the Engineer for consideration.

901-2.2 LIME

ADD: The Contractor shall have the option of using an agricultural ground limestone per Section 1081.07 of the IDOT Standard Specifications for Road and Bridge Construction.

901-2.3 FERTILIZER

DELETE: This Section of the Supplemental Specifications.

REVISE last paragraph to read as follows:

Fertilizer shall be applied at rates that supply the following amounts of nutrients per acre to the distributed areas of seeding:

<u>NUTRIENTS</u>	<u>POUNDS PER ACRE</u>
Nitrogen	90
Phosphorus (P205)	90
Potassium (K20)	<u>90</u>
TOTAL	270

CONSTRUCTION METHODS

901-3.2 DRY APPLICATION METHOD

DELETE: Entire Section

ADD:

- (a) Description: This work shall consist of furnishing, transporting and installing all seeds, plant or other materials required for:
 - 1. Any remedial operations in conformance with the plans as specified in these special provisions or as directed by the Engineer.
- (b) General Requirements: The site will be in the following condition:
 - 1. The grade will be shaped to the elevation shown on the plans.
 - 2. The topsoil will be free of clods, stones, roots, sticks, rivulets, gullies, crusting, caking and have a soil particle size of no larger than 1".
- (c) Seeding Equipment: Seeding equipment shall meet the following requirements. Any other equipment deemed necessary shall be subject to the approval of the Engineer.
 - 1. Disc: Any disc new for the use shall be in a good state of repair with sound, unbroken blades. The disc shall be weighted if necessary to achieve the required tillage depth.
 - 2. No-Till Planters and Drills: Rangeland type drills and no-till planters shall be designed specifically for the seeding of native grasses and forbs with depth control bands set at 1/4" - 1/8".
 - 3. Seedbed Preparation: Seedbed preparation methods shall be approved by the Engineer. Cultivation shall be accomplished at such a time that seeding may occur immediately and without delay. No seeds shall be sown until the Seedbed has been approved by the Engineer.
- (d) Seeding Methods: The Contractor shall submit for approval by the Engineer and schedule for seeding and/or planting at least two weeks prior to the scheduled commencement of work. Broadcast seeders will not be allowed. Seeder will be a drill type planter. The Engineer shall examine and then approve any equipment to be used. Prior to starting work, all seeding equipment shall be calibrated and adjusted to sow seeds at the proper seeding rate. Equipment shall be operated in a manner to insure complete coverage of the entire area to be seeded. The Engineer shall be notified 48 hours prior to beginning the seeding operations. Any gaps between areas of growth greater than eight square feet shall be resown and/or replanted.
 - 1. No-till or Drill Method: Rolling of the Seedbed will not be required with the use of rangeland type grass drill or no-till planters.

METHOD OF MEASUREMENT

901-4.1

ADD:

Quantities will not be distinguished between the various seeding classes and no separate measurement will be made.

Areas of seeding not showing a uniform stand of grass in density and color shall not be approved for payment. Such areas shall be reseeded to the Owner's satisfaction at the Contractor's cost.

BASIS OF PAYMENT

901-5.1

Payment will be made under:

ITEM AR901510 SEEDING PER ACRE.

ITEM 908 – MULCHING

(SUPPLEMENTAL SPECIFICATION)

DESCRIPTION

908-1.1

ADD:

Mulch shall be placed as designated on the plans.

MATERIALS

908-2.1 MULCH MATERIAL

REVISE: The first sentence to read:

Material used for mulching shall be Manufactured Hydraulic Mulch.

908-5.1

Payment will be made under:

ITEM AR908510 MULCHING PER ACRE.

DIVISION VI – LIGHTING INSTALLATION

ITEM 108 – INSTALLATION OF UNDERGROUND CABLE

(SUPPLEMENTAL SPECIFICATION)

DESCRIPTION

108-1.1

ADD:

FAA Specification FAA-GL-918C Specification for Construction of Terminal Navigational Facilities and all other FAA Specifications are included as an appendix in this document. In the event of conflicts between the FAA document and this special provision, the FAA specification shall govern, unless otherwise approved by the Engineer.

EQUIPMENT AND MATERIALS

108-2.2

ADD:

Airfield lighting PAPI and VASI cable under this item shall be:

- 3-1/C #6 XLP-USE 600V, 1/C #8 GND in 1-1/4" unit duct with guard wire
- 3-1/C #4 XLP-USE 600V, 1/C #8 GND in 1-1/4" unit duct with guard wire

Secondary power cable for new electric services under this item shall be:

- 3-1/C # 2, 600V, XHHW
- 1/C #2 XLP-USE

All other cable shall meet the requirements of Section 16 of the FAA Specification for Construction of Terminal Navigation Aid Facilities and all other FAA Specifications, found in the appendix of this document.

108-2.4 CABLE CONNECTIONS

ADD:

To further reduce the possibility of water (moisture) entrance into the connector between the cables and the field-attached connector, heat shrinkable tubing with interior adhesive shall be applied over all cable connections.

The heat shrinkable tubing shall cover the entire L-823 connector. All connections shall be at handholes or light bases. **No direct burial splicing will be allowed.**

No splices will be allowed in the new cable. Cable shall be continuous between pull points. Any repairs necessary to cable damaged during installation shall be done at the Contractor's expense and shall consist of replacing the entire length of damaged cable between pull points.

In line connections for existing cables to be spliced or those that are cut during construction shall be repaired with the cast splice kit. The Contractor shall have a minimum of five (5) splice kits on the jobsite at all times for emergency repairs. Splice markers shall be installed over each splice in cables not to be

abandoned. Cast splice kits shall be as specified in paragraph (a). All field splices shall be covered with a flexible polyolefin heat-shrinkable sleeve.

108-3.1 GENERAL

ADD:

The locations of existing cables are taken from available record maps and it will be necessary for the contractor to make field investigations to determine the exact locations of underground cable and conduits at critical points.

108-3.3 TRENCHING

ADD:

The installation of GRS conduit using the plowing-in method will not be allowed.

All cable in unit-duct may be installed using the plowing-in method or direct burial, (refer to Item 108-3.11) except at critical locations where required to protect existing cables or to facilitate construction.

Modify the Supplemental Specifications to be: Cable plowing shall be done at a minimum depth of 30" below finished grade.

108-3.8 SPLICING

DELETE: Paragraph (b) (c) and (e).

ADD:

Direct burial splicing will not be allowed.

Contractor shall use cast splicing kits as described in Article 108-2.4 for any splices made inside the electric handholes. The cast splicing kit shall be series 82-B1 Scotch cast or 90-B1 Scotch cast as manufactured by 3M or equal. Contractor shall provide shop drawing for splicing method and cast splicing kit. Contractor shall also leave minimum 30" of slack on each side of the cable being spliced. The cost of splicing shall be incidental to the cost of installation of underground cables.

108-3.10 TESTING

ADD:

Testing for 5000V and 600V Airfield Lighting Cable

The cable after installation and in case of series circuit after connection of all isolation transformers, but before connection to power source (constant current regulators, power transformers, disconnect switches, etc.) and/or connection to load other than isolation transformers shall be tested in the following manner:

1. Contractor shall meggar all new circuit after installation and before connection of the circuit to the regulator, power transformer, disconnect switches, etc.

Each test shall last for a minimum of one minute after instrument readings have been stabilized. The minimum acceptable insulation resistance value shall be 50 MEGOHMS.

2. When unacceptable readings are obtained, the Contractor shall locate the fault(s) and correct them.
3. The test equipment and power to operate it shall be furnished and operated by the Contractor to no additional cost. The equipment shall be approved by the Engineer before testing is commenced. All tests shall be witnessed by the Engineer and a representative of the Aurora Municipal Airport.

- 4. Circuit to remain in service will be tested prior to the start of construction to assure they are operational. These same circuit will be tested after construction has been completed, and the readings will be required to be the same or greater than the before construction meggar results.**
5. All cable found to be defective due to installation methods shall be replaced by the Contractor at his expense.

The remaining existing field circuits within the working limits of this contract which are not scheduled to be added or deleted from shall also be megged before any work is performed in the presence of the Engineer and a representative of Aurora Municipal Airport. Any subsequent damage to these existing circuits shall be immediately repaired at no cost to the contract such that meggar readings taken after completion of the repair shall be, as a minimum, equal to the reading taken before the work began.

108-3.13 TERMINATIONS AND CONNECTIONS

ADD:

The Contractor shall have a minimum of five (5) splice kits on the jobsite at all times for emergency repairs.

If, due to the length of spool ordered by the Contractor, it is necessary to install additional handholes, the Contractor shall supply same at no additional cost to the project. The handhole shall be the size as directed by the Engineer.

METHOD OF MEASUREMENT

108-4.1

ADD:

Only secondary power cables between utility transformer and meter base (excluding for new electric service for electric gate) will be measured for payment. Any other cable required for a complete and operational system shall be considered incidental to the shelter building, shelter building relocation, localizer, localizer relocation, glide slope, electric gate and DME installation.

Guard wire shall not be paid for separately but shall be considered incidental to the associated pay item.

BASIS OF PAYMENT

108-5.1

Payment will be made under:

ITEM AR108082	1/C #2 XLP-USE	PER LINEAR FOOT.
ITEM AR800025	3-1/C #4 XLP-USE, 1/C #8 GND. IN UD	PER LINEAR FOOT.
ITEM AR800158	3-1/C #6 XLP-USE 600V, 1/C #8 GND IN UD	PER LINEAR FOOT.

ITEM 110 – INSTALLATION OF AIRPORT UNDERGROUND ELECTRICAL DUCT

(SUPPLEMENTAL SPECIFICATION)

DESCRIPTION

110-1.1

ADD:

This item shall consist of the construction of the new steel duct direct buried and jacked and concrete encased split duct, including appropriate duct markers at the locations shown in the plans or as directed by the Engineer.

Contractor shall provide pull wire for each conduit and cap the unused conduits for future use.

FAA Specification FAA-GL-918C Specification for Construction of Terminal Navigational Facilities and all other FAA Specifications are included as an appendix in this document. In the event of conflicts between the FAA document and this special provision, the FAA specification shall govern, unless otherwise approved by the Engineer.

EQUIPMENT AND MATERIALS

110-2.8 DUCT MARKER

ADD:

The Contractor shall provide duct markers for each new or existing duct being used as detailed in the plans. The cost of installation of the duct markers shall be incidental to the contract.

110-2.9 SPLIT DUCT

ADD:

The Contractor shall install 1-4" PVC concrete encased split duct to accommodate existing airfield cables. Split duct shall be encased in a minimum of 3" of concrete surrounding the 4" PVC split duct. The cost of routing existing cables through the new split ducts and the cost of concrete encasement shall be incidental to the price of split duct.

CONSTRUCTION METHODS

110-3.5 BACKFILLING

ADD:

Crushed Stone conforming to the requirements of Item 208 gradation shall be used for backfill at the pavement crossings for the new duct installation. The granular material shall be compacted to not less than 95% of Standard Proctor laboratory density.

BASIS OF PAYMENT

110-5.1

ADD:

Payment will be made at the contract unit price per lineal foot for each type and size of split duct and GRS conduit completed and accepted. These prices shall be full compensation for furnishing all materials and for all preparation, assembly, duct markers, aggregate backfill, backfill compaction, sawcutting and

installation of these materials, and for all labor, equipment, tools, and incidentals necessary to complete these items.

Trenching and backfilling shall also be included in the installation or removal of the duct and conduit and shall not be paid for separately.

Conduit in trench and pushed for electric gate shall be incidental to the item "AR162716 ELECTRIC GATE – 16"

Payment will be made under:

ITEM AR110212	2" STEEL DUCT, DIRECT BURY	PER LINEAL FOOT.
ITEM AR110214	4" STEEL DUCT, DIRECT BURY	PER LINEAL FOOT.
ITEM AR110314	4" STEEL DUCT, JACKED	PER LINEAL FOOT.
ITEM AR110550	SPLIT DUCT	PER LINEAL FOOT.

ITEM 125 – INSTALLATION OF AIRPORT LIGHTING SYSTEMS

(SUPPLEMENTAL SPECIFICATION)

DESCRIPTION

125-1.1

ADD:

Airfield lighting improvements and modifications shall include:

- Installation of new splice cans.
- Adjust base mounted high intensity runway threshold lights.
- Relocation of existing PAPI Power and Control Unit and 4-Box PAPI light assemblies.

FAA Specification FAA-GL-918C Specification for Construction of Terminal Navigational Facilities and all other FAA Specifications are included as an appendix in this document. In the event of conflicts between the FAA document and this special provision, the FAA specification shall govern, unless otherwise approved by the Engineer.

125-1.2 INSPECTION, TEST AND WARRANTY

VISUAL EXAMINATION

The most important of all inspection and test procedures is thorough visual inspections. Visual inspections shall be made frequently during installation, at completion of installation, and before energizing the circuits. A careful visual inspection can reveal defects that can be corrected prior to acceptance tests and energization. Serious damage may occur if defects are subjected to electrical tests or energization. Visual inspections shall include appraisal of:

- a. Correctness of external connections.
- b. Good work performance.
- c. Cleanliness.

- d. Safety hazards.
- e. Specific requirements listed herein for individual items. While all equipment manufactured under specifications pass strict factory tests prior to shipment, it shall be inspected for shipping damage immediately upon receipt.

ELECTRICAL TESTS ON SERIES LIGHTING CIRCUITS

Before modifying any series circuit, verify the performance of the existing circuit by checking the supply voltage to the regulator and measuring the output current from the regulator on all brightness steps under existing load.

- a. For home run segments that will not be replaced, disconnect at S-1 cutout and at first fixture and verify cable continuity.
- b. Check cable connections and perform electrical tests on cable as specified in Section L-108.

LIGHTING FIXTURES

An inspection shall be made to determine that the color, quantity, and locations of light are in accordance with the installation drawings. Each light shall be inspected to determine that it is operable, glass is not broken or cracked, correct lamps are installed, and it has been properly leveled and aimed, in accordance with technical orders and manufacturers instructions, where applicable.

CONSTANT CURRENT REGULATORS

The supply voltage and input and output current shall be checked at the regulator to see that they operate properly and that regulators are not overloaded due to shorts to ground or excessive leakage.

- a. Visual Examination. Each constant current regulator shall be visually examined to insure that porcelain bushings are not cracked, no shipping damage has occurred, internal and external connections are correct, switches and relays operate freely and are not tied or blocked, fuses (if required) are correct, and that the oil level of oil-filled regulators is correct. Relay panel covers only shall be removed for this examination; it is not necessary to open the main tank of oil-filled regulators. The instructions on the plates attached to the regulator shall be accomplished. After examination and tests are completed, replace all covers tightly.
- b. Electric Tests. The supply voltage and input tap shall be checked to see that they correspond. With the load disconnected, the regulator shall be energized and the open circuit protector observed to see that it de-energizes the regulator within 2 or 3 seconds.

MISCELLANEOUS COMPONENTS

Vault components related to each lighting circuit being modified shall be visually inspected for damage, correct connections, proper fuse and circuit breaker ratings, and compliance with codes.

FINAL ACCEPTANCE TESTS

After components and circuits have been inspected, as specified in the preceding paragraphs, the entire system shall be inspected and tested as follows:

- a. Operate each switch for the modified lighting circuits from the remote control position (L-821 Panel) so that each switch position is reached at least twice. During this process, all lights

and vault equipment shall be observed to determine that each switch properly controls the corresponding circuit.

- b. Repeat the above test using the local control switches on the regulators.
- c. Each lighting circuit shall be tested by operating it continuously at maximum brightness for at least 6 hours. Visual inspection shall be made at the beginning and end of this test to determine that the correct number of lights is operating at full brightness. Dimming of some or all of the lights in a circuit is an indication of grounded cables.
- d. In addition to the above, all equipment shall be subjected to any and all performance tests specified in the manufacturer's instructions.
- e. Photometric testing. The Airport may, upon completion of the lighting installation and as part of acceptance testing, perform field photometric testing of each new light fixture to assure the installed runway lights meet the photometric requirements specified by FAA. The test results will be recorded and furnished to the Contractor, with any noted deficiencies. The Contractor is responsible for correcting any deficiencies at no additional cost to the Owner.

125-1.3 GUARANTEE

All equipment furnished and work performed under the Contract Documents shall be guaranteed against defects in materials or workmanship for a period of one (1) year from the date of final acceptance. This guarantee does not replace any responsibility for errors or omissions as set forth in state law. Any long-term warranties issued or offered by manufacturers for items of equipment shall be turned over to the Airport.

125-1.4

Any failure of equipment or work due to defects in materials or workmanship shall be corrected by the Contractor at no cost to the Airport.

125-1.5

The Contractor shall ascertain that all lighting system components furnished by him (including FAA approved equipment) are compatible in all respects with each other and the remainder of the new/existing system. Any incompatible components furnished by the Contractor shall be replaced by him at no additional cost to the Airport with a similar unit approved by the Engineer (different model or manufacturer) that is compatible with the remainder of the airport lighting system.

125-1.6

The Contractor-installed equipment (including FAA approved) shall not generate any electromagnetic interference in the existing and/or new communications, weather and air traffic control equipment. Any equipment generating such interferences shall be replaced by the Contractor at no additional cost with the equipment meeting applicable specifications and not generating any interference.

EQUIPMENT AND MATERIALS

125-2.1 GENERAL

ADD:

All new equipment shall be listed in Advisory Circular 150/5345-1(Latest Edition) - Approved Airport Lighting Equipment.

Before any electrical materials are ordered, the Contractor shall furnish the Engineer a list of the materials and equipment to be incorporated in the work. This list shall include the name of each item, the Federal Aviation Administration specification number, the manufacturer's name, the manufacturer's catalog number, and the size, type and/or rating of each item, catalog cuts, test data, fuse curves, outline drawings, nameplate drawings, wiring diagrams, and schematic diagrams.

After the list has been approved by the Engineer and prior to installation, the Contractor shall assemble the equipment and materials at a single location, on-site, and request inspection by the Engineer. None of the equipment or materials, other than duct or conduit, may be used on the job until such as inspection has been completed.

All test results from required tests shall be submitted to the Engineer for review and approval.

Airport lighting equipment and materials covered by FAA specifications shall have prior approval of the Federal Aviation Administration, Airport Service, Washington, DC 20591, and shall be listed in the current edition of FAA Advisory Circular AC 150/5345-53, Airport Lighting Equipment Certification Program. All other equipment and materials covered by other referenced specifications shall be subject to acceptance through manufacturer's certification of compliance with the applicable specification, when required by the Engineer.

All FAA Advisory Circular referenced in this specification refer to the most recent edition in circulation.

New materials for the PAPI relocation shall conform to FAA Specification FAA-GL-918C Specification for Construction of Terminal Navigational Facilities and all other FAA Specifications in Appendix A of this Special Provision.

125-2.9 TAPE

Rubber and plastic electrical tapes shall be Scotch Electrical Tape Numbers 23 and 88, respectively, as manufactured by the Minnesota Mining and Manufacturing Company, or an approved equal.

125-2.14 RELOCATE PAPI

ADD:

This item shall include the relocation of the 4-box PAPI and power and control unit on new legs and new anchor foundations as shown on the plans and specified herein. New items to be furnished and installed by the Contractor include the following but are not limited to: all splice cans, splice can anchor foundation, control cable, grounding electrodes and ground wires, cable splices, structural legs, anchor foundation, mounting plates, aiming and testing of the relocated PAPI system, aggregate maintenance areas, restoration of the existing PAPI site, conduits and miscellaneous electrical fittings and couplings.

The installation of 600V cable in unit duct, splicing to existing cables and testing of the cables shall be per Item 108 of the specifications. The installation of the splice cans shall be per item 125 of the specifications.

The removal and disposal of off airport property of the existing PAPI system includes the following but is not limited to: concrete foundations for PAPIs, concrete foundation for PCU, aggregate pads, legs for PAPIs and mounting system for PCU.

Installation for the PAPI relocation shall conform to FAA Specification FAA-GL-918C Specification for Construction of Terminal Navigational Facilities and all other FAA Specifications in Appendix A of this Special Provision.

CONSTRUCTION METHODS

125-3.1 GENERAL

ADD:

The Contractor shall exercise caution in the installation and removal of all light units. Any units damaged by the Contractor's operations shall be repaired or replaced to the satisfaction of the Engineer at no additional cost to the contract.

125-3.3 PHASING AND INTERRUPTIONS

All existing electrical equipment and lighting systems not included in the phase of work being performed must be kept in operation, unless prior approval of the Owner has been received and as otherwise specified below and on the Drawings. The Contractor may use salvaged materials for temporary construction where required. The permission for temporary work and using salvaged materials shall be obtained from the Owner. Lighting for active runway and taxiway surfaces shall be maintained. Work shall be coordinated with paving operations.

Refer to the special provision of the specification for notification requirements and other information regarding work interruptions due to airport operational requirements or Contractor anticipation for exceeding the limitations described in the above paragraph.

125-3.6 LIGHT ADJUSTMENTS

The contractor shall exercise care in the adjustment of existing airfield lights to prevent damage. Any elevated light and concrete bases damaged shall be replaced at no additional cost to the contract.

The elevated lights shall be adjusted true to line and grade. The Contractor will be required to furnish and place construction stakes for the horizontal and vertical alignment layout at each light location. The elevated lights shall be horizontally placed in a straight line to the satisfaction of the Engineer and the Airport Director. Any elevated lights not meeting the Airport Director's satisfaction shall be readjusted at no additional cost to the Airport.

A 4" minimum sand cushion shall be placed on undisturbed earth at the bottom of the base mounted can and compacted mechanically to the satisfaction of the Engineer. After the base mounted can has been adjusted the area around the base shall be filled and compacted in 6 inch loose lifts with an approved IDOT CA-6 material. Each layer shall be deposited all around the base mounted can to approximately the same elevation. Backfill material shall be placed against undisturbed earth and shall be compacted with a mechanical compactor to the satisfaction of the Engineer. Finally, the material shall be "jetted" to insure no additional settlement will occur.

125-3.7 REMOVE REILS

The Contractor shall remove the existing REIL lights and turn over to the Airport. The existing power cables shall be spliced back together to ensure a continuous circuit. The Contractor shall provide and attach a cover which will fit the existing splice can.

METHOD OF MEASUREMENT

125-4.1

DELETE: Entire section.

ADD:

The quantities to be paid for under this item shall consist of:

The number of splice cans for connecting proposed power cables to existing power cables for the PAPI and VASI in place as complete units and accepted by the Engineer. All other splice cans associated with the PAPI relocation and NAVAIDs shall not be paid for separately, but shall be considered incidental to the Relocate PAPI and NAVAIDs respectively.

The number of edge lights adjusted as complete units, ready for operation and accepted by the Engineer. The number of pairs of REILS removed and accepted by the Engineer.

The quantity of Relocate PAPI system to be paid under this item shall be per each, including but not limited to all removals, topsoiling, restoration, excavation, concrete foundations, conduit, bare copper ground wire, control cable, splice cans, ground rods, aiming and testing of relocated PAPI system, aggregate pads, relocation of 4 LHAs, relocation of PCU, cable splices installed as shown in the plans for a complete and operational system and accepted by the Engineer and FAA. Incoming 600 V XLP USE cables with ground in unit duct shall not be paid for under this item but shall be measured and paid for under applicable sections of Item 108.

BASIS OF PAYMENT

125-5.1

ADD:

Payment will be made at the contract unit price for each complete item furnished and installed in place by the Contractor and accepted by the Engineer. This price shall be full compensation for furnishing all materials and for all preparation, removals, modifications, relocation, assembly, and installation of these materials, and for all labor, equipment, tools, and incidentals necessary to complete this item.

Payment for topsoiling and seeding of the Item 125 installation areas shall not be paid for separately but shall be considered incidental to the associated item.

Payment will be made under:

ITEM AR125565	SPLICE CAN	PER EACH.
ITEM AR125907	REMOVE REILS	PER PAIR.
ITEM AR125942	ADJUST BASE MOUNTED LIGHT	PER EACH.
ITEM AR125968	RELOCATE PAPI	PER EACH.

DIVISION VIII – MISCELLANEOUS

ITEM 150510 – ENGINEER'S FIELD OFFICE

CHECK SHEET NO. 5

ENGINEER'S FIELD OFFICE

150-2.1

REVISE:

Paragraph (g) to the following:

- (g) One (1) electric water cooler dispenser capable of dispensing cold and hot water and a supply of water bottles as needed.

Paragraph (j) to the following:

- (j) 1 dry process copy machine (including maintenance and operating supplies) capable of both collating and reproducing prints up to a half size (11"X 17") and capable of copying field books.

ADD:

- (o) One first-aid cabinet fully equipped.
- (p) One (1) 800 Watt, 0.8 cubic foot microwave oven.
- (q) Solid waste disposal consisting of two (2) 28-quart waste baskets.

BASIS OF PAYMENT

150-3.1

DELETE the second sentence of the second paragraph of this section.

Payment will be made under:

ITEM AR150510 ENGINEER'S FIELD OFFICE PER LUMP SUM.

ITEM 127 – AIRPORT NAVAID INSTALLATION

DESCRIPTION

127-1.1

This item shall consist of components of an airport Runway 33 ILS systems and Runway 9 Localizer Relocation system furnished and installed in accordance with this specification and the referenced specifications. The systems shall be installed at the locations and in accordance with the dimensions, design and details shown in the plans. This item shall include the furnishing of all equipment, materials, services, and incidentals necessary to place the systems in operation as completed units to the satisfaction of the Engineer and FAA.

The Contractor shall note that compliance with Items 30-04 and 30-18 of the General Provisions is mandatory and is incidental to the contract work.

When standard drawings are provided for the installation and relocation of existing structures, relocate existing equipment in accordance with these drawings as much as possible. Deviations from the standards are permitted where provided for on the site drawings, or to accommodate nonstandard features of existing structures. The contractor shall check the dimensions of the existing structures and foundations against the standard drawings, note any discrepancies, and report them to the Resident Engineer. The contractor shall construct the new foundation to accommodate these discrepancies.

FAA Specifications FAA-GL-918C Specification for Construction of Terminal Navigational Facilities, FAA-STD-019e Lightning and Surge Protection, Grounding, Bonding, and Shielding Requirements for Facilities and Electronic Equipment, FAA Supplemental Specifications and FAA Special Specifications are included as Appendix A. In the event of conflicts between the FAA Specifications and this Special Provision, the Appendix A FAA Specifications shall govern, unless otherwise approved by the Engineer and FAA.

127-1.2 LOCALIZER INSTALLATION

This item shall include installation of equipment, furnishing all components necessary to construct an operational FAA approved and supportable Localizer system. The Contractor shall construct all components as detailed on the plans.

This item shall include, but not be limited to, the following major items of work by the Contractor:

- Provide equipment and materials not included on the Government Furnished Property list as detailed in the plans
- Antenna Foundations
- Antenna erection
- Excavate and backfill utility trenches for FAA power and control equipment
- Cabling from equipment shelter to Localizer equipment
- Installation of mast and antenna equipment
- Providing assistance to FAA during flight check
- All other incidental items necessary to complete the system

The following major items of work shall be by the FAA:

- Provide Government Furnished Property as detailed in the plans
- Termination of cables at shelter building and localizer antenna
- Tune-up electronic equipment
- Coordinate flight check operations and conduct flight check

Throughout the pertinent portions of this project, the Contractor will arrange for on-site technical support by the equipment manufacturer to provide oversight and guidance during the installation, of the Localizer components. The cost for this support shall be incidental to this item. The Contractor shall be responsible for coordination with the technical representative, for furnishing all materials and for all preparation, assembly, and installation of materials and for all labor, equipment, tools and incidentals necessary to complete this item.

The contractor shall note that the Localizer Shelter equipment building shall **not** be included in this item, but included in Shelter Building.

127-1.3 DME INSTALLATION

This item shall include installation of equipment, furnishing all components necessary to construct an operational FAA approved and supportable DME Slope system. The Contractor shall construct all components as detailed on the plans.

This item shall include, but not be limited to, the following major items of work by the Contractor:

- Provide equipment and materials not included on the Government Furnished Property list as detailed in the plans
- Foundation
- Excavate and backfill utility trenches for FAA power and control equipment
- Cabling and from equipment shelter to DME
- Conduit between shelter and DME
- Providing assistance to FAA during flight check
- All other incidental items necessary to complete the system

The following major items of work shall be by the FAA:

- Provide Government Furnished Property as detailed in the plans
- Termination of cables at shelter building and DME antenna
- Tune-up electronic equipment
- Coordinate flight check operations and conduct flight check

The Contractor shall be responsible for furnishing all materials and for all preparation, assembly, and installation of materials and for all labor, equipment, tools and incidentals necessary to complete this item.

127-1.4 GLIDE SLOPE INSTALLATION

This item shall include installation of equipment, furnishing all components necessary to construct an operational FAA approved and supportable Glide Slope system. The Contractor shall construct all components as detailed on the plans.

This item shall include, but not be limited to, the following major items of work by the Contractor:

- Provide equipment and materials not included on the Government Furnished Property list as detailed in the plans
- Antenna foundation
- Antenna tower erection
- Excavate and backfill utility trenches for FAA power and control equipment
- Cabling from equipment shelter to Glide Slope equipment
- Conduit between shelter and Glide Slope Tower
- Installation of mast
- Providing assistance to FAA during flight check
- All other incidental items necessary to complete the system

The following major items of work shall be by the FAA:

- Provide Government Furnished Property as detailed in the plans
- Termination of cables at shelter building and Glide Slope antenna
- Tune-up electronic equipment
- Coordinate flight check operations and conduct flight check

Throughout the pertinent portions of this project, the Contractor will arrange for on-site technical support by the equipment manufacturer to provide oversight and guidance during the installation of the Glide Slope components. The cost for this support shall be incidental to this item. The Contractor shall be responsible for coordination with the technical representative, for furnishing all materials and for all preparation, assembly, and installation of materials and for all labor, equipment, tools and incidentals necessary to complete this item.

The contractor shall note that the Glide Slope Shelter equipment building shall **not** be included in this item, but included in Shelter Building.

127-1.5 MALSR INSTALLATION

This item shall include furnishing and installing all components necessary to construct an operational FAA approved and supportable MALSR System as specified herein and as detailed on the plans. The system consists of nine (9) MALS bars, five (5) RAIL lights and threshold light bar. The contractor shall construct each component as detailed in the plans.

This item shall include, but not be limited to, the following major items of work by the Contractor:

- Provide equipment and materials not included on the Government Furnished Property list as detailed in the plans
- Threshold Light Bar
- Frangible EMT Light Bar
- LIR MG-20 T-Bar Tower
- LIR MG-30 T-Bar Tower
- MG-20 LIR Flasher Tower
- Tower Maintenance Stand
- Screw Anchor and PCC Foundations
- Lamp holders
- MALSR Lamps
- RAIL Flashers
- Power and Control Wiring
- MALS Distribution and Monitoring Rack
- Alignment, Calibration and Testing in FAA presence
- Providing MALSR test equipment
- Providing MALSR 'Site Spares" equipment
- All other incidental items necessary to complete the system

The following major items of work shall be by the FAA:

- Provide Government Furnished Property as detailed in the plans
- Verify horizontal and vertical aiming of the MALSR lamp assemblies
- Coordinate flight check operations and conduct flight check

Throughout the pertinent portions of this project, the Contractor will arrange for on-site technical support by the equipment manufacturer to provide oversight and guidance during the installation, connection and calibration of the MALSR components. The cost for this support shall be incidental to this item. The Contractor shall be responsible for coordination with the technical representative, for furnishing all materials and for all preparation, assembly, and installation of materials and for all labor, equipment, tools and incidentals necessary to complete this item.

The contractor shall note that the MALSR equipment shelter building shall **not** be included in this item, but included in Shelter Building.

127-1.6 LOCALIZER RELOCATION

This item shall include relocation, installation of equipment, furnishing all components necessary to construct an operational FAA approved and supportable Localizer system. The Contractor shall construct all components as detailed on the plans.

This item shall include, but not be limited to, the following major items of work by the Contractor:

- Provide equipment and materials not included on the Government Furnished Property list as detailed in the plans
- Removal and disposal of existing antenna foundations and existing materials and equipment that are not necessary for the relocation
- Removal of existing antenna
- Antenna Foundations
- Relocate existing antenna and erect
- Excavate and backfill utility trenches for FAA power and control equipment
- Cabling and connections from equipment shelter to Localizer equipment
- Installation of mast and antenna equipment
- Preliminary testing, including ground checks in FAA presence
- Providing assistance to FAA during flight check

The following major items of work shall be by the FAA:

- Provide Government Furnished Property as detailed in the plans
- Tune-up electronic equipment
- Coordinate flight check operations and conduct flight check

Throughout the pertinent portions of this project, the Contractor will arrange for on-site technical support by the equipment manufacturer to provide oversight and guidance during the installation, connection and calibration of the Localizer components. The cost for this support shall be incidental to this item. The Contractor shall be responsible for coordination with the technical representative, for furnishing all materials and for all preparation, assembly, and installation of materials and for all labor, equipment, tools and incidentals necessary to complete this item.

The contractor shall note that the Localizer Shelter equipment building and remove shelter building shall **not** be included in this item, but included in Shelter Building and Shelter Building Removal, respectively.

MATERIALS

127-2.1 GENERAL

All equipment shall be FAR Part 171 certified by the Federal Aviation Administration (FAA) for use on public precision instrument approaches to ILS Category I minimums. The ILS systems shall be acceptable for FAA takeover of ownership and maintenance.

Equipment shall be manufactured, constructed and installed in accordance with the manufacturer's standard plans and specifications. Provide equipment meeting all applicable requirements of the FAA and Federal Communication Commission (FCC).

The owner furnished equipment is shown on the plans as Government Furnished Property List. The Contractor shall provide all other components not being provided by the owner in order to construct a complete and operations ILS.

The contractor shall construct the MALSR System, the Glide Slope System, Localizer System, DME System and Localizer Relocation System as detailed on the plans and in accordance with applicable sections of Divisions 3, 5, 6, 9, 13 and 16 and Supplement of the F.A.A. *SPECIFICATIONS FOR CONSTRUCTION OF TERMINAL NAVIGATIONAL AID FACILITIES* and all other FAA Specifications found in Appendix A of this document. All material shall be subject to acceptance through the manufacturer's certification of compliance.

Should a conflict arise between the Standard/Special Provision specifications and the Appendix A specifications, the Appendix A specifications shall govern.

The Contractor shall ascertain that all lighting system components furnished by him (including FAA approved equipment) are compatible in all respects with each other and remainder of the new/existing system. Any non-compatible components furnished by the Contractor shall be replaced by him at no additional cost with similar unit, approved by the engineer (different model or different manufacturer) that is compatible with the remainder of the airport lighting system.

127-2.2 ILS LOCALIZER AND LOCALIZER RELOCATION

The Contractor shall furnish and install all material, concrete pads and foundations, obstruction light, lightning protection, conduit, wiring and cabling necessary to make the installation complete. Final acceptance of this system will be made by the Resident Engineer, the Airport and the FAA.

127-2.3 DISTANCE MEASURING EQUIPMENT

The Contractor shall furnish and install all material, concrete pads and foundations, obstruction light, lightning protection, conduit, wiring and cabling necessary to make the installation complete. Final acceptance of this system will be made by the Resident Engineer, the Airport and the FAA.

127-2.4 MALSR EQUIPMENT

The Contractor shall provide a MALSR system which conforms to FAA Specification FAA-E02325 and fiberglass masts which conform to FAA Specification FAA-E-2702. All other miscellaneous items which are covered by FAA Standard Specifications shall conform to those specifications as applicable.

The contractor shall furnish all material, concrete pads, electrical cans, LIR towers, conduit, distribution panels, wiring, and cable necessary to make the installation complete. Final acceptance of this system will be made by the Resident Engineer, the Airport and the FAA.

127-2.5 GLIDE SLOPE EQUIPMENT

The Contractor shall furnish and install all material, concrete pads and foundations, obstruction light (by others), lightning protection, conduit, wiring and cabling necessary to make the installation complete. Final acceptance of this system will be made by the Resident Engineer, the Airport and the FAA.

127-2.6 MALSR TEST EQUIPMENT

The Contractor shall provide the following at the MALSR shelter, for FAA takeover:

- Fluke Model 87 Multimeter
- Sequenced Flasher Tester supplied by manufacturer of system
- Sequenced Flasher Lamp Aiming Device
- PAR 38 Lamp Aiming Device

- PAR 56 Lamp Aiming Device

127-2.7 CABLE

Cable used in this installation shall be copper of the type and size shown in the plans and in accordance with FAA-GL-918C, Division 16 - Electrical in Appendix A. Aluminum wire will not be allowed.

127-2.8 CONDUIT

All conduit shall be galvanized rigid steel conforming to FAA-GL-918C Division 16 – Electrical in Appendix A.

127-2.9 BACKFILL

Backfill around duct, conduit and cable entrances shall be an IDOT approved FA-1. All other backfill shall be original material compacted to the requirements of Item 152.

127-2.10 OTHER EQUIPMENT

All other regularly used commercial items of electrical equipment not covered by FAAA equipment specification shall conform to the rulings and standards of the Institute of Electrical and Electron Engineers (IEEE) or the nation Electrical Manufacturers Associations (NEMA). The equipment shall be new and a first grade project. The equipment shall be UL listed as suitable for its intended use.

127-2.11 PRODUCT SUPPORT AND WARRANTY

The contractor shall also provide a warranty for all equipment, materials, and workmanship for one year from the date of systems acceptance. The contractor shall provide and install new parts at no cost to the owner should the system or components fail or become defective within one year from the date of acceptance.

127-2.12 TEST EQUIPMENT

As part of this installation, the Contractor will provide test equipment necessary to perform all calibration and periodic adjustments, FAA ground checks, return to service adjustment, and any other maintenance required to keep the equipment operating at the level necessary for continued certification. The contractor shall provide an itemized list of test equipment to be provided with the ILS hardware for evaluation by the Engineer.

INSTALLATION

127-3.1 GENERAL

The equipment and components shall be installed by personnel experienced with the requirements and techniques involved with similar ILS installations. The personnel shall be thoroughly familiar with National Electrical Code and Federal Communications Commission (FCC) requirements. The personnel shall be thoroughly familiar with airport rules and regulations, and applicable safety requirements.

127-3.2 GROUNDING

The Contractor shall comply with all applicable requirements of FAA Standard 019e.

127-3.3 LOCALIZER REMOVAL

The existing Runway 9 Localizer foundations shall be removed by the Contractor and disposed of off Airport property. Removal of the existing Runway 9 localizer foundation shall be considered incidental to the localizer relocation.

127-3.4 ILS POWER MODIFICATIONS

The existing disconnect for VASI power mounted to the existing Runway 9 localizer building shall be removed and relocated to the new Runway localizer building. Furnish and install new circuit breaker, conduit and cable between panelboard and disconnect and connect VASI power cables to the relocated disconnect as shown on the plans or as directed by the Resident Engineer.

METHOD OF MEASUREMENT

127-4.1 LOCALIZER

The quantity of Localizer to be paid for under this item shall be measured per lump sum furnished and installed as completed units in place, ready for operation, and accepted by the Engineer and Federal Aviation Administration.

127-4.2 DME

The quantity of DME to be paid for under this item shall be measured per lump sum furnished and installed as completed units in place, ready for operation, and accepted by the Engineer and Federal Aviation Administration.

127-4.3 GLIDESLOPE

The quantity of Glideslope to be paid for under this item shall be measured per lump sum furnished and installed as completed units in place, ready for operation, and accepted by the Engineer and Federal Aviation Administration.

127-4.4 MALSR INSTALLATION

The quantity of MALSR to be paid for under this item shall be measured per lump sum furnished and installed as completed units in place, ready for operation, and accepted by the Engineer and Federal Aviation Administration.

127-4.5 RELOCATE LOCALIZER

The quantity of Localizer relocation to be paid for under this item shall be measured per lump sum relocated as completed units in place, ready for operation, and accepted by the Engineer and Federal Aviation Administration.

127-4.6 ILS POWER MODIFICATIONS

Removal and relocation of existing disconnect for VASI and installation of proposed circuit breakers, conduit and wiring for a complete VASI power inside the ILS equipment shelter as detailed on the plans and as directed by the Engineer shall be paid under item AR800030 ILS POWER MODIFICATIONS.

BASIS OF PAYMENT

127-5.1 LOCALIZER

Payment will be made at the lump sum contract unit price for the complete, operational and accepted Localizer System. This price shall be full compensation for furnishing, assembling and installing Owner furnished equipment; compensation for furnishing, assembling and installing Contractor furnished equipment; for providing manufacturer's support; for antenna array foundations; for furnishing and installing conduits, splice cans, cables and grounding system; for furnishing and installing all materials, labor equipment and incidentals.

This item shall also include the required testing of the completed system as specified.

127-5.2 DME

Payment will be made at the lump sum contract unit price for the complete, operational and accepted DME System. This price shall be full compensation for furnishing, assembling and installing Owner furnished equipment; compensation for furnishing, assembling and installing Contractor furnished equipment; for providing manufacturer's support; for DME foundation; for furnishing and installing conduits, splice cans, cables and grounding system; for furnishing and installing all materials, labor equipment and incidentals.

This item shall also include the required testing of the completed system as specified.

127-5.3 GLIDESLOPE

Payment will be made at the lump sum contract unit price for the complete, operational and accepted Glideslope System. This price shall be full compensation for furnishing, assembling and installing Owner furnished equipment; compensation for furnishing, assembling and installing Contractor furnished equipment; for providing manufacturer's support; for antenna tower foundation; for furnishing and installing conduits, splice cans, cables and grounding system; for furnishing and installing all materials, labor equipment and incidentals.

This item shall also include the required testing of the completed system as specified.

127-5.4 MALSR INSTALLATION

Payment will be made at the lump sum contract unit price for the complete, operational and accepted MALSR and MALS Threshold Light Bar System. This price shall be full compensation for furnishing, assembling and installing Owner furnished equipment; compensation for furnishing, assembling and installing Contractor furnished equipment; for providing manufacturer's support; for light bar foundations; for furnishing and installing conduits, splice cans, cables and grounding system; for furnishing and installing all materials, labor equipment and incidentals.

This item shall also include the required testing of the completed system as specified.

127-5.5 RELOCATE LOCALIZER

Payment will be made at the lump sum contract unit price for the complete, operational and accepted Relocated Localizer System. This price shall be full compensation for furnishing, assembling and installing Owner furnished equipment and relocated equipment; compensation for furnishing, assembling and installing Contractor furnished equipment; for providing manufacturer's support; for removing existing foundations and for new antenna array foundations; for furnishing and installing conduits, splice cans, cables and grounding system; for furnishing and installing all materials, labor equipment and incidentals.

This item shall also include the required testing of the completed system as specified.

127-5.6 ILS POWER MODIFICATIONS

Payment will be made at the lump sum contract unit price for the complete, operational and accepted ILS power modifications. This price shall be full compensation for furnishing, removing, relocating and installing existing and proposed VASI power equipment; disconnect, connection to relocated disconnect, compensation for furnishing, assembling and installing Contractor furnished equipment; for furnishing and installing conduits, cables and circuit breaker; for furnishing and installing all materials, labor equipment and incidentals.

This item shall also include the required testing of the completed system as specified.

Payment shall be made under:

AR127410	LOCALIZER	PER LUMP SUM.
AR127415	DME	PER LUMP SUM.
AR127420	GLIDESLOPE	PER LUMP SUM.
AR127450	MALSR INSTALLATION	PER LUMP SUM.
AR127961	RELOCATE LOCALIZER	PER LUMP SUM.
AR800030	ILS POWER MODIFICATIONS	PER LUMP SUM.

ITEM 127430 – SHELTER BUILDING

DESCRIPTION

127430-1.1

This item shall include furnishing and installing all components necessary to construct operational equipment shelter buildings for ILS installations. The Contractor shall construct the shelter building as detailed on the plans.

The owner furnished equipment is shown on the plans as Government Furnished Property List. The Contractor shall provide all other components not being provided by the owner in order to construct a complete and operations ILS.

This item shall include, but not be limited to, the following major items of work:

- Carpentry
- Foundation and Stairs

- Flooring
- Painting
- Conduits and wiring
- Lightning protection and grounding (per FAA-STD-OI9e)
- Electric utility service, including meter base and transformer pad.
- Coordination with ComEd for new electric service.

FAA Specifications FAA-GL-918C Specification for Construction of Terminal Navigational Facilities and FAA-STD-019e Lightning and Surge Protection, Grounding, Bonding, and Shielding Requirements for Facilities and Electronic Equipment and other FAA Specifications are included as appendices in this document. In the even of conflicts between the FAA documents and this special provision, the FAA specifications shall govern, unless otherwise approved by the Engineer.

All material used to construct the shelter building and the entire ILS system as a whole shall meet FAA approval.

MATERIALS

127430-2.1 GENERAL

The Contractor shall construct the Equipment Shelter Building as detailed on the plans and in accordance with applicable sections of Divisions 3, 5, 6, 9, 13 and 16 of the FAA Specifications for Construction of Terminal Navigation Aid Facilities and all other FAA Specifications, found in the appendix of this document. All material shall be subject to acceptance through the manufacturer's certification of compliance. The Contractor shall note that the requirements of Division 13 Section 13E shall apply to the Shelter Buildings on this project.

In instances where the special provisions are in conflict with the FAA Specifications for Construction of Terminal Navigation Aid Facilities, the FAA specifications shall govern.

The Contractor shall furnish all material, concrete pads and foundations, ground rods and grounding, rigid steel conduit, wiring and cabling necessary to make each equipment shelter building complete. Final acceptance of this system will be made by the Engineer, the Airport, and the FAA.

The Contractor shall ascertain all system components furnished by him (including FAA approved equipment) are compatible in all respects with each other and with FAA-furnished equipment. Any non-compatible components furnished by the contractor shall be replaced by him at no additional cost with a similar unit, approved by the Engineer that is compatible with the remainder of the ILS system.

127430-2.2 CABLE

Cable used in this installation shall be copper and of the type and size shown in the plans and in accordance with Section 108. Aluminum wire will not be allowed.

127430-2.3 CONDUIT

All conduit shall be galvanized rigid steel conforming to Section 110.

127430-2.4 OTHER EQUIPMENT

All other regularly used commercial items of electrical equipment not covered by FAA equipment specifications shall conform to the rulings and standards of the Institute of Electrical and Electronic Engineers (IEEE) or the National Electrical Manufacturers Association (NEMA). The equipment shall be new and a first grade product. The equipment shall be UL listed as suitable for its intended use.

127430-2.5 UTILITY SERVICE

The Contractor shall furnish a 120/240 volt, single phase utility service for the equipment shelter buildings, capacity as shown on the plans. The Contractor shall be responsible for contacting the serving agency (ComEd) and obtaining this utility service for each shelter building. The contractor shall comply with all requirements of the serving utility, including, but not limited to, installation of the transformer pad, utility meter base, conduits, wiring and meter base.

The utility service for the shelter building will not be paid for separately but shall be considered incidental to furnishing and installing the shelter building.

127430-2.6 CONCRETE

Concrete used for foundation and other miscellaneous shelter items shall conform to Section 610.

CONSTRUCTION METHODS

127430-3.1 GENERAL

The Contractor shall comply with all applicable requirements of the FAA Specifications for Construction of Terminal Navigational Facilities and all other FAA Specifications, found in the appendix of this document and the NFPA National Electric Code, latest edition.

127430-3.2 GROUNDING AND LIGHTNING PROTECTION

The Contractor shall install and test grounding and lightning protection system as shown on the plans and to comply with all applicable requirements of FAA Standard 019e. In the event of conflicts between the FAA standard specifications FAA-STD-019e and details on the plans and this special provision, the FAA standard specification shall govern, unless otherwise approved by the Engineer.

METHOD OF MEASUREMENT

127430-4.1

The quantity of equipment shelter building installation to be paid for under this item shall be measured per each for furnishing and installing all materials, labor, equipment and incidentals necessary to make this a complete, operational and accepted system.

BASIS OF PAYMENT

127430-5.1

Payment will be made at the contract unit price for each Shelter Building. This price shall be full compensation for furnishing, assembling and installing Owner furnished equipment; compensation for furnishing, assembling and installing Contractor furnished equipment; for furnishing and installing conduits, cables and grounding system; for furnishing and installing all materials, labor equipment and incidentals.

Payment shall be made under:

AR127430	SHELTER BUILDING	PER EACH.
-----------------	-------------------------	------------------

ITEM 127903 – REMOVE SHELTER BUILDING

DESCRIPTION

127903-1.1 GENERAL

This item shall consist of furnishing all materials, labor, equipment, tools, and incidentals necessary to completely remove the building/structure designated above, its contents, and/or its foundation to the satisfaction of the Engineer.

127903-1.2 UTILITIES

The Contractor shall be responsible for locating all utility lines within the area of the shelter buildings. Existing utilities that are to be abandoned because of the demolition shall be cut, sealed and abandoned. This work shall be done in cooperation with the utility companies involved and shall conform to all federal, state, and local requirements.

CONSTRUCTION METHODS

127903-2.1 GENERAL

At the locations shown on the plans, the Contractor shall completely demolish and remove the existing building/structures from the project site. The foundation walls and concrete floors shall also be completely removed, where applicable. The remaining hole or void which exists within the ditch slopes following the structure foundation removal shall be filled to within 4" of existing adjacent ground level with clay material in conformance with Section 152 of the specifications. Topsoil material shall be placed in the top 4" of the fill. The site shall be graded to drain with surrounding features.

Any unfilled hole, void, or any other hazard left unattended during periods of inactivity shall be properly fenced or protected by the Contractor.

The Contractor shall break all concrete floors, pads, ramps and foundation walls into pieces not exceeding two feet (2') square.

The entire site as shown on the plans, or as directed by the Engineer, shall be smoothly graded and turfed where applicable. Turfing shall include topsoiling, permanent seeding and mulching of those areas designated on the plans. The Contractor shall leave the site free of rubble and debris, and in a condition satisfactory to the Engineer. All rubble and debris shall be disposed of by the Contractor off the airport property at a landfill or approved dumping area. The Contractor shall provide the Engineer with a ticket or receipt from the landfill or dumping area for each load of material hauled from the project site.

METHOD OF MEASUREMENT

127903-3.1

The quantity of equipment shelter buildings to be removed to be paid for under this item shall be measured per each for completely removing and disposing of all portions of the structures and restoring the site to the satisfaction of the Engineer.

BASIS OF PAYMENT

127903-4.1

This work will be paid for at the contract unit price for each shelter building removed, which shall be compensation in full for the complete removal and disposal of the existing structure, foundation, and all debris and any necessary incidentals.

Payment for backfilling the resultant void with unclassified excavation material and landscaping including the 4" topsoil placement will not be paid for separately.

Payment shall be made under:

AR127903 REMOVE SHELTER BUILDING PER EACH.

ITEM 800101 – DELINEATOR

DESCRIPTION

800101-1.1

This item consists of the installation of roadside delineators as shown on the plans or as directed by the Engineer.

MATERIALS

800101-2.1

The delineators shall meet the requirements of Section 635, *Delineators*, of IDOT's *Standard Specifications for Road and Bridge Construction*.

The roadside delineators shall conform to IDOT Standard Detail 635001 and 720011.

CONSTRUCTION METHODS

800101-3.1

Installation of delineators shall be according to Section 635, *Delineators*, of IDOT's *Standard Specifications for Road and Bridge Construction*.

METHOD OF MEASUREMENT

800101-4.1

The delineators shall be measured per each satisfactorily installed and accepted by the Engineer.

BASIS OF PAYMENT

800101-5.1

Payment shall constitute full compensation for the construction of the delineators, including all materials, labor, tools, equipment and necessary incidentals to complete this item of work.

Payment will be made under:

ITEM AR800101 DELINEATOR PER EACH

ITEM 800119 – REMOVE GRAVEL

DESCRIPTION

800119-1.1

This item shall consist of removing an existing gravel roadway of the thickness and to the grades shown on the plans.

CONSTRUCTION METHODS

800119-2.1

Material obtained from removal operations shall be hauled to the existing west haul road location and graded smoothly and compacted by the Contractor as shown on the plans or as designated by the Resident Engineer. No additional compensation will be made for hauling removed material. Upon gravel removal, topsoiling and landscaping the site shall be in accordance with Item 152 and Items 901 and 908, respectively.

METHOD OF MEASUREMENT

800119-3.1

The yardage to be paid for shall be the number of cubic yards of gravel removal as measured in the field, completed and accepted.

BASIS OF PAYMENT

800119-4.1

The accepted quantities of gravel removal will be paid for at the contract unit price per cubic yard which price and payment shall be full compensation for furnishing of all materials, equipment, labor, hauling and disposal and all other incidental items necessary to complete the work to the satisfaction of the Engineer.

Payment will be made under:

ITEM AR800119 REMOVE GRAVEL PER CUBIC YARD.

ITEM 800123 – CABLE BARRIER GATE

DESCRIPTION

800123-1.1

This item shall consist of the installation of cable barrier gates as shown on the plans or as directed by the Engineer.

MATERIALS

800123-2.1

The 3" galvanized pipe shall conform to the requirements of Section 110-2.5.

The concrete shall conform to the requirements of Item 610.

CONSTRUCTION METHODS

800123-3.1

Installation shall be as shown in the plans. All keys to the padlock shall be turned over to the FAA.

METHOD OF MEASUREMENT

800123-4.1

The cable barrier gates shall be measured per each satisfactorily installed and accepted by the Engineer.

BASIS OF PAYMENT

800123-5.1

Payment shall constitute full compensation for the construction of the cable barrier gates, including all materials, labor, tools, equipment and necessary incidentals to complete this item of work.

Payment will be made under:

ITEM AR800123	CABLE BARRIER GATE	PER EACH.
----------------------	---------------------------	------------------

ITEM 800124 – ADJUST GLIDESLOPE

DESCRIPTION

800124-1.1

This item shall consist of lowering the top of the glideslope tower to 5' -0" maximum height above the centerline of top antenna element as shown on the plans or as directed by the Engineer. FAA will complete the final antenna element location based on achieving the best signal generation. This item may not be necessary depending on the final antenna element location and may be deleted from the contract at no additional cost to the contract.

MATERIALS

800124-2.1

Materials shall be as shown on the plans and per FAA Specifications FAA-GL-918C Specification for Construction of Terminal Navigational Facilities and all other FAA Specifications in Appendix A.

CONSTRUCTION METHODS

800124-3.1

Installation shall be as shown in the plans and per FAA Specifications FAA-GL-918C Specification for Construction of Terminal Navigational Facilities and all other FAA Specifications in Appendix A.

METHOD OF MEASUREMENT

800124-4.1

The Adjust Glideslope shall be measured per lump sum satisfactorily installed and accepted by the Engineer.

BASIS OF PAYMENT

800124-5.1

Payment shall constitute full compensation for the construction of the glideslope adjustment and any remobilization costs, including all materials, labor, tools, equipment and necessary incidentals to complete this item of work.

Payment will be made under:

ITEM AR800124 ADJUST GLIDESLOPE PER LUMP SUM.

ITEM 800145 – LOCALIZER GROUND CHECK POINT

DESCRIPTION

800145-1.1

This item shall consist of the installation of localizer ground check points as shown on the plans or as directed by the Engineer.

MATERIALS

800145-2.1

The 1" galvanized pipe shall conform to the requirements of Section 110-2.5.

The crushed rock shall conform to the requirements of Section 209-2.3 (IDOT CA-6).

CONSTRUCTION METHODS

800145-3.1

Installation shall be as shown in the plans. The crushed rock shall be compacted to the satisfaction of the Engineer.

METHOD OF MEASUREMENT

800145-4.1

The localizer ground check points shall be measured per each satisfactorily installed and accepted by the Engineer.

BASIS OF PAYMENT

800145-5.1

Payment shall constitute full compensation for the construction of the localizer ground check points, including all materials, labor, tools, equipment and necessary incidentals to complete this item of work.

Payment will be made under:

ITEM AR800145 LOCALIZER GROUND CHECK POINT PER EACH.

ITEM 910420 – BOLLARD

DESCRIPTION

910420-1.1

This item shall consist of the installation of bollards as shown on the plans or as directed by the Engineer.

MATERIALS

910420-2.1

Materials shall be as shown on the plans. Concrete shall meet Item 610.

CONSTRUCTION METHODS

910420-3.1

Installation shall be as shown in the plans.

METHOD OF MEASUREMENT

910420-4.1

The bollards shall be measured per each satisfactorily installed and accepted by the Engineer.

BASIS OF PAYMENT

910420-5.1

Payment shall constitute full compensation for the construction of the bollards, including all materials, labor, tools, equipment and necessary incidentals to complete this item of work.

Payment will be made under:

ITEM AR910420

BOLLARD

PER EACH.

IDA POLICY MEMORANDUMS

State of Illinois
Department of Transportation
Division of Aeronautics

POLICY MEMORANDUM

January 1, 2004

Springfield

Number: 87-2

TO: CONSULTING ENGINEERS

SUBJECT: DENSITY ACCEPTANCE OF BITUMINOUS PAVEMENTS

1. Introduction

This Policy Memorandum deals with the implementation of the Bituminous Density Quality Assurance specifications as a revision to the Standard Specification for Construction of Airports, January 1985. These revisions are to Item 201 Bituminous Base Course, and Item 401 Bituminous Surface Course.

II. Sampling

After completion of compaction and the pavement has reached ambient temperature, the paved area shall be divided into Sublots of 500 tons per type of mix. One core sample (2 cores per sample) shall be taken from each Sublot. The longitudinal and transverse location for each sample shall be determined by use of a random number "Deck" provided by the Division. No core shall be taken closer than two (2) feet from the edge of the mat. A core extraction device as illustrated by the attachment is recommended. All cores are to be taken by the contractor under the supervision and remain in the possession of the engineer. It is imperative that the Engineer and the contractor realize that the cores are "Money" and that improper coring, extraction, shipping and/or testing can be costly.

One mix sample per 1000 tons of mix laid shall be taken for Extraction, Maximum Specific Gravity (G_{mm}) and Air Void tests. The mix samples shall be sampled by the contractor and split in half.

The Resident Engineer shall randomly designate and send the split samples to an independent laboratory for testing. The laboratory will be designated by the Division of Aeronautics. The frequency of testing split samples shall be 1 per 5000 tons. Higher frequencies may be necessary if the contractor's tests, and/or mix quality control are inconsistent.

III. Testing

All cores shall be tested for Bulk Specific Gravity (G_{sb}) in accordance with ASTM D2726 using Procedure 9.1, "For Specimens That Contain Moisture". The Theoretical Maximum Gravity (G_{mm}) shall be determined according to ASTM D2041, Procedure 7. From these tests the in-place air voids of the compacted pavement are calculated according to ASTM D3203 for "dense bituminous paving mixtures". Selection of the proper G_{mm} shall be based on a running average of four (4) tests per Lot.

Eg. Lot 1 - Use the average of the two (2) tests for Lot 1.

Lot 2 - Use the average of the four (4) tests from Lots 1 and 2.

Lot 3 - Use the average of the four (4) tests from Lots 2 and 3.

NOTE: When more than four (4) Sublots are used, still use a running average of four (4) tests per Lot.

IV. Acceptance Calculations

The first step in calculating the quantities for pay is to calculate the Mean (\bar{x}) and the Standard Deviation (S) of the Sublot tests. From this data the Lot samples should first be tested for outliers. After consideration for outliers, the Percent Within Tolerance (PWT) and the Percent Within Limits (PWL) are calculated to determine the final pay quantities for the Lot.

EXAMPLE

1. Test Data

Lot Quantity = 2000 tons
Sublot Test 1 = 4.35 % Air
Sublot Test 2 = 3.96 % Air
Sublot Test 3 = 6.75 % Air
Sublot Test 4 = 6.25 % Air

2. Calculating the Mean and Standard Deviation

Sublot	\underline{x}	$(\underline{x} - \bar{x})$	$(\underline{x} - \bar{x})^2$
1	4.35	- 0.978	0.956
2	3.96	- 1.368	1.871
3	6.75	1.422	2.022
4	<u>6.25</u>	0.922	<u>0.850</u>
Sum =	21.31		5.699

$$N = 4$$

$$\text{Mean}(\bar{x}) = 5.328$$

$$\text{Variance } (S)^2 = \frac{\text{Sum}(X - \bar{X})^2}{3} = \frac{5.699}{3} = 1.900$$

$$\text{Standard Deviation } S = \sqrt{1.900} = 1.378$$

3. Test For Outliers

Check for Critical "T" Values

$$T = \frac{|(X_1 - \bar{X})|}{S} = \frac{|3.96 - 5.328|}{1.378} = 0.99$$

* Difference between the suspect test value (X_1) and the Mean (\bar{X}).

If the T value exceeds the critical "T" Value in the table below and no assignable cause can be determined for the outlier, discard the suspected test measurement and obtain another random sample from the Lot in question. If the new test exceeds the Mean (\bar{X}) in the same direction from the Mean as the suspected test, recalculate the T value including all tests (original test, suspected test, and new test) for an outlier and for computing final payment.

TABLE OF CRITICAL "T" VALUES

Number of observations (N)	Critical "T" Value 5% Significance Level
3	1.15
4	1.46
5	1.67
6	1.82
7	1.94
8	2.03
9	2.11
10	2.18
11	2.23
12	2.29

Based on the above table, the "T" value of 0.99 does not exceed the Critical "T" Value of 1.46 for N = 4. Therefore, the value (3.96) is not an outlier and shall be used in calculating the Lot payment.

4. Calculation of Lot Payment

To calculate the Lot Payment use the Acceptance Criteria as outlined under Item 201-4.13(c) or Item 401-4.13(c).

$$Q_L = \frac{(\bar{X} - 1)}{S} = \frac{5.328 - 1}{1.378} = 3.141$$

$$Q_u = \frac{(7 - \bar{X})}{S} = \frac{7-5.328}{1.378} = 1.213$$

From this data the Percentage Within Tolerance (PWT) for both the lower and upper tolerance limits is determined by Table 8 of the specifications for the number (N) of samples tested.

$$\begin{aligned} \text{Eq. PWT (lower)} &= 99.0\% \\ \text{PWT (upper)} &= 90.4\% \end{aligned}$$

We now calculate the Percent Within Limits (PWL) for the Lot.

$$\begin{aligned} \text{PWL} &= [\text{PWT (lower)}] + [\text{PWT (upper)}] - 100 \\ \text{PWL} &= (99.0 + 90.4) - 100 = 89.4\% \end{aligned}$$

Using Table 7, the % Adjustment in Lot Quantity is:

$$\begin{aligned} \% \text{ Adjustment} &= 0.5 \text{ PWL} + 55.0 \\ \% \text{ Adjustment} &= 0.5 (89.4) + 55.0 \\ \% \text{ Adjustment} &= 99.7 \end{aligned}$$

$$\begin{aligned} \text{Adjusted Quantities} &= \% \text{ Adjustment} \times \text{Lot Quantities} \\ \text{Adjusted Quantities} &= .997 \times 2000 \text{ tons} \\ \text{Adjusted Quantities} &= 1994 \text{ tons} \end{aligned}$$

5. Resampling and Retesting

Under the specifications the contractor has the right to request the resampling and retesting of a complete Lot. This privilege is only allowed once for each Lot and must be requested in writing by the contractor within 48 hours of receiving the official report from the Engineer.

6. Reporting

After completion of the tests for each Lot, the Engineer shall complete the necessary calculations for final adjustment in quantities on the Form AER M-1 and have both the Engineer and the Contractor sign the report for copying to both the FAA and IDOA.

Steven J. Long, P.E.
Acting Chief Engineer

Supersedes Policy Memorandum 87-2, dated January 1, 1999.

State of Illinois
Department of Transportation
Division of Aeronautics

POLICY MEMORANDUM

January 1, 2004

Springfield

Number: 87-4

TO: CONSULTING ENGINEERS

SUBJECT: DETERMINATION OF BULK SPECIFIC GRAVITY (d)
OF COMPACTED BITUMINOUS MIXES

- A. SCOPE. This method of test covers the determination of the bulk specific gravity and the percent air, of core samples from compacted bituminous mixtures using a saturated surface-dry procedure.
- B. DEFINITIONS.
1. Bulk Specific Gravity (G_{sb}) or density is the weight per unit volume (gms/cc) of a mixture in its existing state of consolidation. The volume measurement for this specific gravity will include the volume of all the aggregate, asphalt, and air spaces (voids) in the aggregate particles and between the aggregate particles.
 2. Theoretical Maximum Specific Gravity (G_{mm}) ASTM 2041 is the weight per unit volume (grams/cc) of a mixture assuming complete consolidation; i.e., all the air spaces (voids) between the aggregate particles are eliminated.
 3. Percent Density is a measure of the degree of compaction in relation to the Theoretical Maximum Specific Gravity.
 4. Percent Air is a measure of the air voids in the compacted pavement.
- C. APPARATUS.
1. Balance - The balance shall be accurate to 0.1 gm throughout the operating range. It may be mechanical or electrical and shall be equipped with a suitable suspension apparatus and holder to permit weighing of the core in water while suspended from the balance. If the balance is a beam type, it shall be set up so that the core is placed in the basket that is suspended from the zero (0) end of the balance arm.
 2. Water bath - The container for immersing the core in water while suspended from the balance shall be equipped with an overflow outlet for maintaining a constant water level. This water bath should be large enough to handle full-depth cores. When testing several cores at the same time, a dish-pan, sink or suitable container may be used for soaking.

D. PROCEDURE.

1. Prior to testing, cores shall be sorted on a flat surface in a cool place. The sample(s) shall be brushed with a wire brush and/or other suitable means, to remove all loose and/or foreign materials, such as seal coat, tack coat, foundation material, soil, paper, and foil, prior to testing.
2. If a core contains binder and surface or multiple lifts, the lifts shall be separated. This may be done in the following manner:
 - a. Mark the separation line between the two lifts.
 - b. Place the core in a freezer for 20-25 minutes.
 - c. Place a 2 or 3-inch wide chisel on the separation line and tap with a hammer. Rotate the core and continue this process until the core separates. Brush loose pieces with a wire brush if needed.
 - d. Allow 2-3 hours for the core to return to ambient temperature before proceeding.
3. Prepare the water baths for soaking and weighing with water at 77° F. Water baths should be maintained at this temperature throughout testing. Saturate the cores by submerging in the water for a minimum of 20 minutes.
4. With the balance and water bath properly assembled and zeroed, suspend the sample from the balance and submerge it in the water bath. The core must be placed with the original top and bottom in a vertical position. If necessary, add sufficient water to bring the water level up to the overflow outlet. Permit any excess to overflow. Read and record the Saturated Submerged Weight. Designate this weight as (C).
5. Remove the core from the water bath and blot the excess water from the surface of the core with an absorbent cloth or other suitable material. This must be done quickly to prevent the internal water from escaping.
6. Place the core on the balance and read and record the Saturated Surface-dry Weight in air. Designate this weight as (B).
7. Place the core in a tared pan and dry in an oven. When the core is dry, (less than 0.5 gm loss in one hour) record the weight and subtract the pan weight. Designate this weight as (A).

8. The following calculation is used to determine the Bulk Specific Gravity of the core.

$$G_{sb} = \frac{A}{B-C}$$

G_{sb} = Bulk Specific Gravity
A = Oven dry weight
B = Saturated surface-dry weight
C = Saturated submerged weight

- E. PERCENT DENSITY. The following calculation is used to determine the percent density of the core:

$$\% \text{ Density} = 100 \times \frac{G_{sb}}{G_{mm}}$$

G_{sb} = Bulk Specific Gravity
 G_{mm} = Theoretical Maximum Gravity*

Note: The Theoretical Maximum Gravity (G_{mm}) is determined from the mix design until current Vacuum Pycnometer test are available.

- F. PERCENT AIR. To calculate the percent air, use the following formula:

$$\% \text{ Air} = 100 - \% \text{ Density}$$

- G. WEIGHT PER SQUARE YARD OF COMPACTED MIXTURE. The actual weight per square yard of a compacted mixture can be calculated by using the Bulk Specific Gravity (G_{sb}). The volume of a square yard of pavement one (1) inch thick is 0.75 cubic foot. Taking the weight of a cubic foot of water as 62.37 pounds, one square yard of compacted material, one (1) inch thick weighs:

$$\text{Pounds Per Sq. Yd. (1" thick)} = 0.75 \times 62.37 \times G_{sb}$$

Steven J. Long, P.E.
Acting Chief Engineer

Supersedes Policy Memorandum 87-4 effective January 1, 1994.

State of Illinois
Department of Transportation
Division of Aeronautics

POLICY MEMORANDUM

January 1, 2004

Springfield

Number 96-1

TO: CONSULTING ENGINEERS

SUBJECT: ITEM 610, STRUCTURAL PORTLAND CEMENT CONCRETE:
JOB MIX FORMULA APPROVAL & PRODUCTION TESTING.

- I. This policy memorandum addresses the Job Mix Formula (JMF) approval process and production testing requirements when Item 610 is specified for an airport construction contract.
- II. PROCESS
 - a. The contractor may submit a mix design with recent substantiating test data or he may submit a mix design generated by the Illinois Division of Highways with recent substantiating test data for approval consideration. The mix design should be submitted to the Resident Engineer.
 - b. The Resident Engineer should verify that each component of the proposed mix meets the requirements set forth under Item 610 of the *Standard Specifications for Construction of Airports* and/or the contract special provisions.
 - c. The mix design should also indicate the following information:
 1. The name, address, and producer/supplier number for the concrete.
 2. The source, producer/supplier number, gradation, quality, and SSD weight for the proposed coarse and fine aggregates.
 3. The source, producer/supplier number, type, and weight of the proposed flyash and/or cement.
 4. The source, producer/supplier number, dosage rate or dosage of all admixtures.
 - d. After completion of Items b and c above, the mix with substantiating test data shall be forwarded to the Division of Aeronautics for approval. Once the mix has been approved the production testing shall be at the rate in Section III as specified herein.

III. PRODUCTION TESTING

- a. One set of cylinders or beams, depending on the strength specified, shall be cast for acceptance testing for each day the mix is used. In addition, at least one slump and one air test shall be conducted for each day the mix is used. If more than 100 c.y. of the mix is placed in a given day, additional tests at a frequently of 1 per 100 c.y. shall be taken for strength, slump, and air. In **no** case will concrete with a slump greater than 4 inches be allowed for use on the project.
- b. If the total proposed amount of Item 610 Structural Portland Cement Concrete as calculated by the Resident Engineer is less than 50 c.y. for the entire project, the following shall apply:
 - The Resident Engineer shall provide a copy of the calculations of the quantity of Item 610 to the Division of Aeronautics.
 - One set of cylinders or beams, depending the strength specified, shall be cast for acceptance testing.
 - One air content and one slump test shall be taken for acceptance testing.
 - In no case will concrete with a slump greater than 4 inches be allowed for use on the project.
- c. The Resident Engineer shall collect actual batch weight tickets for every batch of Item 610 concrete used for the project. The actual batch weight tickets shall be kept with the project records and shall be available upon request of the Department of Transportation.

Steven J. Long, P.E.
Acting Chief Engineer

Supersedes Policy Memorandum 96-1 dated January 1, 2003

State of Illinois
Department of Transportation
Division of Aeronautics

POLICY MEMORANDUM

April 1, 2004

Springfield, Illinois

Number 96-2

TO: CONTRACTORS

SUBJECT: REQUIREMENTS FOR LABORATORY, TESTING, QUALITY CONTROL, AND PAVING OF BITUMINOUS CONCRETE MIXTURES

I. SCOPE

The purpose of this policy memorandum is to define to the Contractor the requirements concerning the laboratory, testing, Quality Control, and paving of bituminous concrete mixtures. References are made to the most recent issue of the Standard Specifications for Construction of Airports and to American Society for Testing and Materials (ASTM) testing methods. The Quality Assurance and acceptance responsibilities of the Engineer are described in Policy Memorandum 96-3.

II. LABORATORY

The Contractor shall provide a laboratory located at the plant and approved by the Illinois Division of Aeronautics (IDA). The laboratory shall be of sufficient size and be furnished with the necessary equipment and supplies for adequately and safely performing the Contractor's Quality Control testing as well as the Engineer's acceptance testing as described in Policy Memorandum 96-3.

The effective working area of the laboratory shall be a minimum of 600 square feet with a ceiling height of not less than 7.5 feet. Lighting shall be adequate to illuminate all working areas. It shall be equipped with heating and air conditioning units to maintain a temperature of 70° F ± 5° F.

The laboratory shall have equipment that is in good working order and that meets the requirements set forth in the following ASTM test standards:

ASTM C 117	Test Method for Materials Finer than 75 µm (No. 200) Sieve in Mineral Aggregates by Washing
ASTM C 136	Sieve or Screen Analysis of Fine and Coarse Aggregate
ASTM C 566	Total Moisture Content of Aggregate by Drying
ASTM D 75	Sampling Aggregates
ASTM D 1559	Resistance to Plastic Flow of Bituminous Mixtures Using Marshall Apparatus
ASTM D 2041	Theoretical Maximum Specific Gravity and Density of Bituminous Paving Mixtures
ASTM D 2172	Quantitative Extraction of Bitumen from Bituminous Paving Mixtures
IDOT	Ignition Method for Determining Asphalt Content

ASTM D 2726	Bulk Specific Gravity of Compacted Bituminous Mixtures using Saturated Surface Dry Specimens
ASTM D 3203	Percent Air Voids in Compacted Dense and Open Bituminous Paving Mixtures
ASTM D 2950	Density of Bituminous Concrete in Place by Nuclear Method
ASTM D 4125	Asphalt Content of Bituminous Mixtures by Nuclear Method
ASTM C 127	Standard Test Method for Specific Gravity and Absorption of Coarse Aggregate
ASTM C 128	Standard Test Method for Specific Gravity and Absorption of Fine Aggregate

The Asphalt Institute's *Mix Design Methods for Asphalt Concrete Manual No. 2 (MS-2)*

The laboratory and equipment furnished by the Contractor shall be properly calibrated and maintained. The Contractor shall maintain a record of calibration results at the laboratory. The Engineer may inspect measuring and testing devices at any time to confirm both calibration and condition. If the Resident Engineer determines that the equipment is not within the limits of dimensions or calibration described in the appropriate test method, the Engineer may stop production until corrective action is taken. If laboratory equipment becomes inoperable or insufficient to keep up with mix production testing, the Contractor shall cease mix production until adequate and/or sufficient equipment is provided.

III. MIX DESIGN TESTING

The Mix Design letter with accompanying approved Job Mix Formula (JMF) will be issued by the IDA Engineer of Materials. The Contractor will be required to perform the sampling and laboratory testing for the mix design according to the following guidelines: [Note: A testing summary chart can be found in Appendix B.]

A. Material sources meeting the requirements of the contract shall be submitted in writing at or before the preconstruction conference in the following format:

1. To: Steve Long, Acting Chief Engineer
Attn: Mike Wilhelm, Engineer of Materials
Division of Aeronautics
One Langhorne Bond Drive
Springfield, Illinois 62707
2. Producer name and location of each aggregate
3. Producer # for each aggregate (producers are assigned this number by IDOT Central Bureau of Materials)
4. Material code for each aggregate
5. Gradation and Quality designation for each aggregate (i.e. CA-11, etc.)
6. Producer, producer #, and specific gravities of asphalt cement

7. Performance Graded Binder 64-22 shall be used unless otherwise approved by the IDA Engineer of Materials.
- B. The Contractor shall obtain representative samples of each aggregate. The individual obtaining samples shall have successfully completed the IDOT Aggregate Technician Course under the IDOT Division of Highways, QC/QA program. The sample size shall be approximately 280 lb. for each coarse aggregate, 150 lb. for each fine aggregate, 15 lb. for the mineral filler or collected dust, and 1 gallon of asphalt cement.
- C. The Contractor shall split the aggregate samples down and run gradation tests according to the testing methods referenced in Appendix B of this memorandum. The remaining aggregates shall be set aside for further Mix Design testing. The results of the gradation tests, along with the most recent stockpile gradations, shall be reported by fax to the IDA Engineer of Materials for engineering evaluation. If the gradation results are deemed non-representative or in any way unacceptable, new representative samples may be required at the direction of the IDA Engineer of Materials. Only composite gradations are required under this procedure.
- D. Based on the accepted gradation results, the IDA Engineer of Materials will return blend percentages for each aggregate to be used in determining the Job Mix Formula. In addition, the Engineer of Materials shall specify directions for mix temperature and asphalt content(s), and number of Marshall Blows for preparation of the Marshall Mix Design.
- E. After receipt of the information from step D., the Contractor shall make specimens and perform the following tests for each asphalt content specified by the Engineer. [Note: Actual test designation is referenced in Appendix B of this memorandum.]

Marshall Tests

Maximum Specific Gravity -- " G_{mm} "

Bulk Specific Gravity -- " G_{sb} "

Marshall Stability

Marshall Flow

% air voids

- F. All technicians who will be performing mix design testing and plant sampling/testing shall have successfully completed the IDOT Division of Highways Bituminous Concrete Level 1 Technician Course "Bituminous Concrete Testing". The Contractor may also provide a Gradation Technician who has successfully completed the Department's "Gradation Technician Course" to run gradation tests only under the supervision of a Bituminous Concrete Level 2 Technician.
- G. The mix design testing results shall be reported to the IDA Engineer of Materials.
- H. The IDA Engineer of Materials shall generate and issue the approved Mix Design with the Job Mix Formula (JMF) for the manufacture of bituminous mixtures using the Contractor's testing results.
- I. The above procedure, III. MIX DESIGN TESTING, shall be repeated for each change in source or gradation of materials.

IV. MIX PRODUCTION TESTING

The Quality Control of the manufacture and placement of bituminous mixtures is the responsibility of the Contractor. The Contractor shall perform or have performed the inspection and tests required to assure conformance to contract requirements. Quality Control includes the recognition of defects and their immediate correction. This may require increased testing, communication of test results to the plant or the job site, modification of operations, suspension of bituminous mix production, rejection of material, or other actions as appropriate. The Resident Engineer shall be immediately notified of any failing tests and subsequent remedial action. Form AER M-14 shall be reported to the Engineer and Resident Engineer no later than the start of the next work day. In addition, AER M-9 and M-11 shall be given to the Resident Engineer daily (Appendix A). The Contractor shall provide a Quality Control (QC) Manager who will have overall responsibility and authority for Quality Control. This individual shall have successfully completed the IDOT Division of Highways Bituminous Concrete Level II Technician Course "Bituminous Concrete Proportioning and Mixture Evaluation." In addition to the QC Manager, the Contractor shall provide sufficient and qualified personnel to perform the required visual inspections, sampling, testing, and documentation in a timely manner. The following plant tests and documentation shall be required: [Note: A summary chart of testing can be found in Appendix B.]

- A. Minimum of one (1) complete hot bin or combined belt analysis per day of production or every 1,000 tons, whichever is more frequent.
- B. Minimum one (1) stockpile gradation for each aggregate and/or mineral filler per week when a batch plant is utilized. Minimum of one (1) gradation for each aggregate per day of production or every 1,000 tons when a drum plant is used, and one (1) gradation per week for mineral filler when a drum plant is used.
- C. A certification from the quarry for the total quantity of aggregate listing the source, gradation type, and quality designation of aggregate shipped.
- D. Original asphalt shipping tickets listing the source and type of asphalt shipped.
- E. One mix sample per 1,000 tons of mix. The sample shall be split in half. One half shall be reserved for testing by the Engineer. The other half shall be split and tested by the Contractor for Marshall, Extraction, Gradation, Maximum Specific Gravity, and Air Void tests in accordance with the appropriate ASTM standard referenced herein. [See Appendix B.]
 - 1. In place of the extraction test, the Contractor may provide the asphalt content by a calibrated ignition oven test using the IDOT Division of Highways' latest procedure. The correction (calibration) factor for aggregate type shall be clearly indicated in the reported test results.

From these tests, the Contractor shall interpret the test data and make necessary adjustments to the production process in order to comply with the approved JMF.

V. QUALITY CONTROL

A. Control Limits

Target values shall be determined from the approved JMF. The target values shall be plotted on the control charts within the following control limits:

<u>Parameter</u>	<u>Control Limits</u>	
	<u>Individual Test</u>	<u>Moving Avg. of 4</u>
% Passing		
1/2 in.	± 7 %	± 4 %
No. 4	± 7 %	± 4 %
No. 8	± 5 %	± 3 %
No. 30	± 4 %	± 2.5 %
No. 200 *	± 2.0 % *	± 1.0 % *
Asphalt Content	± 0.45 %	± 0.2 %

* No. 200 material percents shall be based on washed samples. Dry sieve gradations (-200) shall be adjusted based on anticipated degradation in the mixing process.

B. Control Charts

Standardized control charts shall be maintained by the Contractor at the field laboratory. The control charts shall be displayed and be accessible at the field laboratory at all times for review by the Engineer. The individual required test results obtained by the Contractor shall be recorded on the control chart immediately upon completion of a test, but no later than 24 hours after sampling. Only the required plant tests and resamples shall be recorded on the control chart. Any additional testing of check samples may be used for controlling the Contractor's processes, but shall be documented in the plant diary.

The results of assurance tests performed by the Engineer will be posted as soon as available.

The following parameters shall be recorded on control charts:

1. Combined Gradation of Hot-Bin or Combined Belt Aggregate Samples (Drier Drum). (% Passing 1/2 in., No. 4., No. 8, No. 30, and No. 200 Sieves)
2. Asphalt Content
3. Bulk Specific Gravity of Marshall Sample
4. Maximum Specific Gravity of Mixture

C. Corrective Action for Required Plant Tests

Control Limits for each required parameter, both individual tests and the average of four tests, shall be exhibited on control charts. Test results shall be posted within the time limits previously outlined.

1. Individual Test Result. When an individual test result exceeds its control limit, the Contractor shall immediately resample and retest. If at the end of the day no material remains from which to resample, the first sample taken the following day shall serve as the resample as well as the first sample of the day. This result shall be recorded as a retest. If the retest passes, the Contractor may continue the required plant test frequency. Additional check samples should be taken to verify mix compliance.
2. Asphalt Content. If the retest for asphalt content exceeds control limits, mix production shall cease and immediate corrective action shall be instituted by the Contractor. After corrective action, mix production shall be restarted, the mix production shall be stabilized, and the Contractor shall immediately resample and retest. Mix production may continue when approved by the Engineer. The corrective action shall be documented.

Inability to control mix production is cause for the Engineer to stop the operation until the Contractor completes the investigation identifying the problems causing failing test results.

3. Combined Aggregate/Hot-Bin. For combined aggregate/hot-bin retest failures, immediate corrective action shall be instituted by the Contractor. After corrective action, the Contractor shall immediately resample and retest. The corrective action shall be documented.
 - a. Moving Average. When the moving average values trend toward the moving average control limits, the Contractor shall take corrective action and increase the sampling and testing frequency. The corrective action shall be documented.

The Contractor shall notify the Engineer whenever the moving average values exceed the moving average control limits. If two consecutive moving average values fall outside the moving average control limits, the Contractor shall cease operations. Corrective action shall be immediately instituted by the Contractor. Operations shall not be reinstated without the approval of the Engineer. Failure to cease operations shall subject all subsequently produced material to be considered unacceptable.
 - b. Mix Production Control. If the Contractor is not controlling the production process and is making no effort to take corrective action, the operation shall stop.

VI. TEST SECTION AND DENSITY ACCEPTANCE (Note: Applies only when specified.)

- A. The purpose of the test section is to determine if the mix is acceptable and can be compacted to a consistent passing density.

A quick way to determine the compactibility of the mix is by the use of a nuclear density gauge in the construction of a growth curve. An easy way to construct a growth curve is to use a good vibratory roller. To construct the curve, an area the width of the roller in the middle of the mat is chosen and the roller is allowed to make one compactive pass. With the roller stopped some 30 feet away, a nuclear reading is taken and the outline of the gauge is marked on the pavement. The roller then makes a compaction pass in the opposite direction and another reading is taken. This scenario is continued until at least two (2) passes are made past the maximum density obtained.

The maximum laboratory density potential of a given mix is a direct function of the mix design air voids. Whereas, the actual maximum field density is a function of the type of coarse aggregates, natural or manufactured sands, lift thickness, roller type (static or vibratory), roller and paver speed, base condition, mix variation, etc. All of these items are taken into consideration with the growth curve.

1. High Density in the Growth Curve. If the growth curve indicates a maximum achievable field density of between 95 to 98 percent of the Theoretical Maximum Density (D), you can proceed with the Rolling Pattern. On the other hand, if the maximum achievable density is greater than 98 percent, a quick evaluation (by use of an extractor, hot bin gradations, nuclear asphalt determinator, etc.) must be made of the mix. When adjustments are made in the mix, a new growth curve shall be constructed.
2. Low Density in the Growth Curve. If the growth curve indicates the maximum achievable density is below 94 percent, a thorough evaluation of the mix, rollers, and laydown operations should be made. After a thorough evaluation of all factors (mix, rollers, etc.), asphalt or gradation changes may be in order as directed by the Engineer. Again, any changes in the mix will require a new growth curve. Note that the nuclear density test is a quality control tool and not an acceptance test. All acceptance testing is to be conducted by the use of cores, unless otherwise specified.
3. Acceptance of Test Section. The Contractor may proceed with paving the day after the test section provided the following criteria have been met:
 - a. Four random locations (2 cores per location cut longitudinally and cored by the Contractor) will be selected by the Engineer within the test strip. The cores must show a minimum of 94% density.
 - b. All Marshall and extraction test results from mix produced for the test section must be within the tolerances required by specification.
 - c. The Contractor shall correlate his nuclear gauge to the cores taken in the test section. Additional cores may be taken at the Contractor's expense for this purpose within the test section area, when approved by the Engineer.
4. Density Acceptance under Production Paving. The responsibility for obtaining the specified density lies with the Contractor. Therefore, it is important that the nuclear density gauge operator communicate with the roller operators to maintain the specified density requirements. The Contractor shall provide a Bituminous Concrete Density Tester who has successfully completed the Department's "Bituminous Concrete Nuclear Density Testing Course" to run all required density tests on the job site. Density acceptance testing, unless otherwise specified, is described as follows:
 - a. The Contractor shall cut cores at random locations within 500 ton sublots as directed by the Resident Engineer.
 - b. The cores should be extracted so as not to damage them, since they are used to calculate the Contractor's pay.
 - c. The Engineer will run preliminary G_{mb} tests on the cores to give the Contractor an indication of how compaction is running for the next day's paving.

- d. A running average of four (4) Maximum Theoretical Gravities (G_{mm}) will be used for calculating percent compaction.
- e. Final core density tests and pay calculations will be performed by the Resident Engineer and delivered to the Contractor.

Steven J. Long, P.E.
Acting Chief Engineer

Supersedes Policy Memorandum 96-2 dated April 1, 2003

APPENDIX A

BITUMINOUS WORKSHEET

Airport: _____ Project No.: _____ AIP No.: _____

Mix Design #: _____ Material Code: _____ Producer: _____
Prod. #: _____

AGGREGATE

Mat'l. Code: _____

Producer #: _____

Prod. Name _____

Location: _____

Percent Passing

Sieve Size

1 inch	_____	_____	_____	_____	_____
3/4 inch	_____	_____	_____	_____	_____
1/2 inch	_____	_____	_____	_____	_____
3/8 inch	_____	_____	_____	_____	_____
No. 4	_____	_____	_____	_____	_____
No. 8	_____	_____	_____	_____	_____
No. 16	_____	_____	_____	_____	_____
No. 30	_____	_____	_____	_____	_____
No. 50	_____	_____	_____	_____	_____
No. 100	_____	_____	_____	_____	_____
No. 200	_____	_____	_____	_____	_____
Washed (y/n)	_____	_____	_____	_____	_____
O.D. Gravity	_____	_____	_____	_____	_____
App. Gravity	_____	_____	_____	_____	_____
Absorption	_____	_____	_____	_____	_____
Asphalt Gravity	_____	Asphalt Source	_____	Asphalt Producer No.	_____

MARSHALL DATA

% Asphalt _____

M. Stability _____

Flow _____

D _____

0 _____

% Air Voids _____

Q.C. Manager Name: _____ Phone number: _____

Laboratory Location: _____ Fax Number: _____

Remarks: _____

Bituminous Mixtures Extraction

Airport: _____ Date: _____
 Consultant: _____

Illinois Project: _____ Contractor: _____

AIP Project No.: _____ Producer: _____

Mix #: _____ Dry Time: _____ Lot: _____ Sublot: _____

Type: _____ Washed: _____

Sieve	Wt.	Accum. Wt.	% Passing	Mix Formula	Tolerance	Spec Range
1.5						
1						
3/4						
1/2						
3/8						
4						
8						
16						
30						
50						
100						
200						
Tot Agg						
Bit						

Extraction Data	g
Pan, New Filter & Sample	g
Pan & New Filter	g
Sample	g
Pan, Used Filter, Aggregate	g
Pan & New Filter	g
Aggregate	g
Pan & Used Filter	g
Pan & New Filter	g
Dust in Filter	g
Sample	g
Aggregate	g
Bitumen	g

New Bit:	Marshall Stab:	Blows:	Gyro:	TSR:
Bulk SPGR:	Max SPGR:	% Voids:	DEN (PCF):	Flow:

Remarks: _____

CC: _____ Tested by: _____

APPENDIX B

QUALITY CONTROL TESTING (PLANT)

PARAMETER	FREQUENCY	SAMPLE SIZE	TEST METHOD	REPORT FORM
Aggregate Gradations: Hot bins for batch and continuous plants--- Individual cold-feeds or combined belt-feeds for drier drum plants.	Minimum 1 per day of production and at least 1 per 1000 tons.	CA07/11: 5000 gm CA13: 2000 gm CA16: 1500 gm Fine agg: 500 gm 1 gallon asphalt cement	ASTM C 136	AER M-9
Aggregate gradations: Stockpiles	Minimum 1 per aggregate per week per stockpile.	CA07/11: 5000 gm CA13: 2000 gm CA16: 1500 gm Fine agg: 500 gm *Note: The above test sample sizes are to be obtained from splitting down a larger sample from the stockpiles.	ASTM C 136	AER M-9
Maximum Specific Gravity	Minimum 1 per 1000 tons	1200 gm per test	ASTM D 2041	AER M-11 and AERM-14
Bulk Specific Gravity	Minimum 1 per 1000 tons	1250 gm per briquette	ASTM D 2726	AER M-11 and AERM-14
Marshall Stability and Flow	Minimum 1 per 1000 tons	1250 gm per briquette	ASTM D 1559	AER M-11 and AERM-14
% Air Voids	Minimum 1 per 1000 tons		ASTM D 3203	AER M-11 and AERM-14
Extraction	Minimum 1 per 1000 tons	1000 gm (surface) 1500 gm (base)	ASTM D 2172	AER M-11 and AERM-14
Ignition Oven Test	Minimum 1 per 1000 tons	1500 gm		AER M-14
Nuclear Asphalt Gauge	Minimum 1 per 1000 tons	1000-1100 gm	ASTM D 2145	AER M-14

MIX DESIGN TESTING

PARAMETER	FREQUENCY	SAMPLE SIZE	TEST METHOD	REPORT FORM
Representative samples of each aggregate and asphalt cement.	1 per aggregate and 1 asphalt cement.	280 lb. (coarse) 150 lb. (fine) 15 lb. (min. filler) 1 gallon asphalt cement	ASTM D 75	N/A
Aggregate Gradation	1 per aggregate	CA07/11: 5000 gm CA13: 2000 gm CA16: 1500 gm Fine agg: 500 gm	ASTM C 136	Bituminous Worksheet (Appendix A)
Maximum Specific Gravity	2 per specified asphalt content	1200 gm per test	ASTM D 2041	Bituminous Worksheet (Appendix A)
Bulk Specific Gravity	3 briquettes per specified asphalt content	1250 gm per briquette	ASTM D 2726	Bituminous Worksheet (Appendix A)
Marshall Stability and Flow	3 briquettes	1250 gm per briquette	ASTM D 1559	Bituminous Worksheet (Appendix A)
% Air Voids	1 per specified asphalt content (Avg. of G_{sb}/G_{mm})		ASTM D 3203	Bituminous Worksheet (Appendix A)

QUALITY CONTROL TESTING (PAVER)

PARAMETER	FREQUENCY	SAMPLE SIZE	TEST METHOD	REPORT FORM
Nuclear Density Test	As required by the Contractor to maintain consistent passing density	Various locations	ASTM D 2950	

State of Illinois
Department of Transportation
Division of Aeronautics

POLICY MEMORANDUM

January 1, 2004

Springfield, Illinois

Number 96-3

TO: CONSULTING ENGINEERS

SUBJECT: REQUIREMENTS FOR QUALITY ASSURANCE ON PROJECTS
WITH BITUMINOUS CONCRETE PAVING

I. SCOPE

The purpose of this policy memorandum is to define to the Consulting Engineer the requirements concerning Quality Assurance on bituminous concrete paving projects. Specifically, this memo applies whenever the Contractor is required to comply with the requirements set forth in Policy Memorandum 96-2, "*Requirements for Laboratory, Testing, Quality Control, and Paving of Bituminous Concrete Mixtures*".

II. LABORATORY APPROVAL

The Resident Engineer shall review and approve the Contractor's plant laboratory to assure that it meets the requirements set forth in the contract specifications and Policy Memorandum 96-2. This review and approval shall be completed prior to utilization of the plant for the production of any mix.

III. QUALITY ASSURANCE DURING PRODUCTION PAVING

A. At the option of the Engineer, independent assurance tests may be performed on split samples taken by the Contractor for Quality Control testing. In addition, the Resident Engineer shall witness the sampling and splitting of these samples at the start of production and as needed throughout mix production. The Engineer may select any or all split samples for assurance testing. These tests may be performed at any time after sampling. The test results will be made available to the Contractor as soon as they become available.

B. The Resident Engineer may witness the sampling and testing being performed by the Contractor. If the Resident Engineer determines that the sampling and Quality Control tests are not being performed according to the applicable test procedures, the Engineer may stop production until corrective action is taken. The Resident Engineer will promptly notify the Contractor, both verbally and in writing, of observed deficiencies. The Resident Engineer will document all witnessed samples and tests. The Resident Engineer may elect to obtain samples for testing, separate from the Contractor's Quality Control process, to verify specification compliance.

1. Differences between the Contractor's and the Engineer's split sample test results will be considered acceptable if within the following limits:

<u>Test Parameter</u>	<u>Acceptable Limits of Precision</u>
% Passing	
1/2 in.	5.0 %
No. 4	5.0 %
No. 8	3.0 %
No. 30	2.0 %
No. 200	2.2 %
Asphalt Content	0.3 %
Maximum Specific Gravity of Mixture	0.026
Bulk Specific Gravity of Marshall Sample	0.045

2. In the event a comparison of the required plant test results is outside the above acceptable limits of precision, split or independent samples fail the control limits, an extraction indicates non-specification mix, or a continual trend of difference between Contractor and Engineer test results is identified, the Engineer will immediately investigate. The Engineer may suspend production while the investigation is in progress. The investigation may include testing by the Engineer of any remaining split samples or a comparison of split sample test results on the mix currently being produced. The investigation may also include review and observation of the Contractor's technician performance, testing procedure, and equipment. If a problem is identified with the mix, the Contractor shall take immediate corrective action. After corrective action, both the Contractor and the Engineer shall immediately resample and retest.

- C. The Contractor shall be responsible for documenting all observations, records of inspection, adjustments to the mixture, test results, retest results, and corrective actions in a bound hardback field book or bound diary which will become the property of IDA upon completion and acceptance of the project. The Contractor shall be responsible for the maintenance of all permanent records whether obtained by the Contractor, the Contractor's Consultants, or the producer of bituminous mix material. The Contractor shall provide the Engineer full access to all documentation throughout the progress of the work.

Results of adjustments to mixture production and tests shall be recorded in duplicate and sent to the Engineer.

IV. ACCEPTANCE BY ENGINEER

Density acceptance shall be performed according to Policy Memorandum 87-2, or according to the acceptance procedure outlined in the Special Provisions.

Steven J. Long, P.E.
Acting Chief Engineer

Supersedes Policy Memorandum 96-3 dated January 1, 1997

State of Illinois
Department of Transportation
Division of Aeronautics

POLICY MEMORANDUM

January 1, 2004

Springfield, Illinois

Number 97-2

TO: CONSULTING ENGINEERS

SUBJECT: PAVEMENT MARKING PAINT ACCEPTANCE

I. SCOPE

The purpose of this policy memorandum is to define the procedure for acceptance of pavement marking paint.

II. RESIDENT ENGINEER'S DUTIES

The Resident Engineer shall follow the acceptance procedure outlined as follows:

- A. Require the painting contractor to furnish the name of the paint manufacturer and the batch number proposed for use prior to beginning work. Notify the I.D.A. Materials Certification Engineer when this information is available.
- B. Require the manufacturer's certification before painting begins. Check the certification for compliance to the contract specifications.
 1. The certification shall be issued from the manufacturer and shall include the specification and the batch number.
 2. The paint containers shall have the manufacturer's name, the specification and the batch number matching the certification.
- C. If no batch number is indicated on the certification or containers, sample the paint according to the procedure for the corresponding paint type.
- D. If the I.D.A. Engineer of Materials indicates that batch number has not been previously sampled and tested, sample the paint according to the procedure for the corresponding paint type. The Division of Aeronautics will provide paint cans upon request by the Resident Engineer. Samples will only be taken in new epoxy lined cans so that the paint will not be contaminated. It is important to seal the sample container immediately with a tight cover to prevent the loss of volatile solvents.

Mark the sample cans with the paint color, manufacturer's name, and batch number. The paint samples and manufacturer's certification shall be placed in the mail within 24 hours after sampling. Address the samples to the Materials Certification Engineer at:

Illinois Department of Transportation
Division of Aeronautics
One Langhorne Bond Drive
Springfield, Illinois 62707

Sampling Procedures for Each Paint Type:

1. Waterborne or Solvent Base Paints
 - a. Take the paint sample from the spray nozzle when the contractor begins marking. A sample consists of two one-pint cans taken per batch number.
 - b. Be sure to indicate to the contractor that acceptance of material is based upon a passing test of the paint material.

2. Epoxy Paint
 - a. Take separate one-pint samples of each paint component prior to marking. Before drawing samples, the contents of each component's container must be thoroughly mixed to make certain that any settled portion is fully dispersed. **Do not combine the two components or sample from the spray nozzle.**
 - b. Be sure to indicate to the contractor that acceptance of material is based upon a passing test of the paint material.

III. TESTING

The paint will be tested for acceptance by the IDOT Bureau of Materials and Physical Research for conformance to the contract specifications.

Steven J. Long, P.E.
Acting Chief Engineer

Supersedes policy memorandum 97-2 dated February 27, 2002

IDOT STANDARD DRAWINGS

PIPE DIA.	THICKNESS	DIMENSIONS						SLOPE (Approx.) (V/H)	BODY
		A	B	H	L	W			
300	1.63 (12)	25± (1)	38± (1 1/2)	50± (2)	150 (6)	150 (6)	1:2 1/2	1 Pc.	
375	1.63 (15)	150 (6)	150 (6)	150 (6)	535 (21)	610 (24)	1:2 1/2	1 Pc.	
450	1.63 (18)	180 (7)	205 (8)	150 (6)	660 (26)	760 (30)	1:2 1/2	1 Pc.	
525	1.63 (21)	205 (8)	255 (10)	150 (6)	785 (31)	915 (36)	1:2 1/2	1 Pc.	
600	1.63 (24)	230 (9)	305 (12)	150 (6)	915 (36)	1,065 (42)	1:2 1/2	1 Pc.	
750	2.01 (30)	255 (10)	330 (13)	166 (6)	1,040 (41)	1,220 (48)	1:2 1/2	1 Pc.	
900	2.01 (36)	305 (12)	405 (16)	166 (6)	1,295 (51)	1,525 (60)	1:2 1/2	1 Pc.	
1050	2.77 (42)	355 (14)	480 (19)	172 (7)	1,525 (60)	1,830 (72)	1:2 1/2	2 Pc.	
1200	2.77 (48)	405 (16)	560 (22)	172 (7)	1,750 (69)	2,135 (84)	1:2 1/4	2 Pc.	
1350	2.77 (54)	455 (18)	685 (27)	172 (7)	1,980 (78)	2,285 (90)	1:2	2 Pc.	
1500	2.77 (60)	455 (18)	760 (30)	172 (7)	2,135 (84)	2,590 (102)	1:1 3/4	3 Pc.	
1650	2.77 (66)	455 (18)	840 (33)	172 (7)	2,210 (87)	2,895 (114)	1:1 1/2	3 Pc.	
1800	2.77 (72)	455 (18)	915 (36)	172 (7)	2,210 (87)	3,050 (120)	1:1 1/3	3 Pc.	
1950	2.77 (78)	455 (18)	990 (39)	172 (7)	2,210 (87)	3,200 (126)	1:1 1/4	3 Pc.	
2250	2.77 (84)	455 (18)	1,065 (42)	172 (7)	2,210 (87)	3,355 (132)	1:1 1/6	3 Pc.	

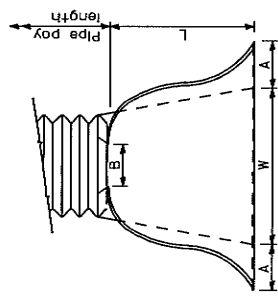

PLAN

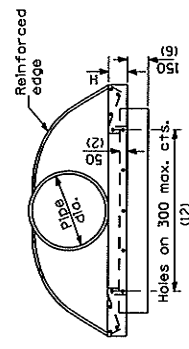

END VIEW

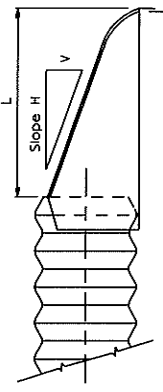

SIDE VIEW

NOTES

For 1500 mm (60") thru 2250 mm (84") sizes, reinforced edges shall be supplemented with stiffener angles. The angles shall be 51x51x6.4 mm (2x2x 1/4") for 1500 mm (60") thru 1800 mm (72") diameter and 76x76x6.4 mm (3x3x 1/4") for 1950 mm (78") thru 2250 mm (84") diameter. The angles shall be attached by M10 (3/8") rivets or bolts.

All slope ratios are expressed as units of horizontal displacement (V/H).

END SECTION

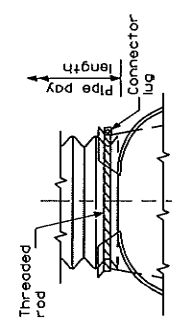

TYPE 1

For 300 (12) thru 600 (24) only (See Note 1)

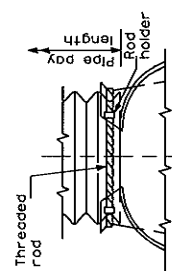

TYPE 2

For 750 (30) and 900 (36) only (See Note 1)

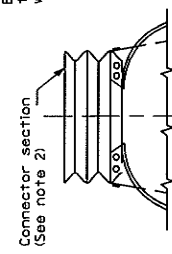

TYPE 3

(See Note 2)

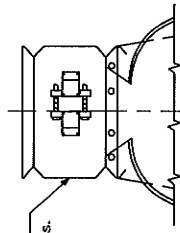

TYPE 4

(See Note 3)

NOTES

- Types 1 and 2 for pipes with annular ends only.
- Type 3 connection can be used for all pipe sizes and includes 300 mm (12") of the pipe length. The connector section shall be attached to the end section by rivets or bolts and shall be the same metal thickness as the end section. Stub shall be either 68 mm (2 3/4") pitch x 13 mm (1/2") depth or 75 mm (3") pitch x 25 mm (1") depth annular corrugated pipe.
- Type 4 connection can be used for all pipe sizes. Coupler shall be 68 mm x 13 mm (2 3/4" x 1/2") annular lug or annular dimple. Hanger or annular band may be used with corrugated metal pipes having annular ends. For corrugated metal pipes having helical ends, only the dimple band will be allowed.

All dimensions are in millimeters (inches) unless otherwise shown.



ALTERNATE STRAP CONNECTOR (For Type 1 only)

28 (1) Wide, 2.77 (0.109) Thick Strap with Standard M12x150 (1/2x6) Band Bolt and Nut.

Illinois Department of Transportation
 PASSED
 APPROVED
 ENGINEER OF SAFETY AND PARTICIPATION
 1987
 ISSUED 1-1-97
 ENGINEER OF DESIGN AND ENVIRONMENT

CONNECTIONS OF END SECTIONS

DATE	REVISIONS
1-1-97	Renum. Standard 222B-5.
6-15-94	Moved 3 Notes to Specs.
	Added Metric.

METAL END SECTION FOR PIPE CULVERTS

STANDARD 542401

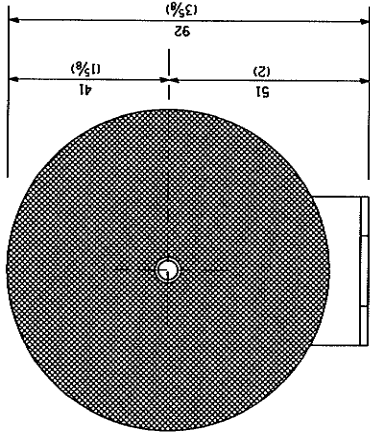
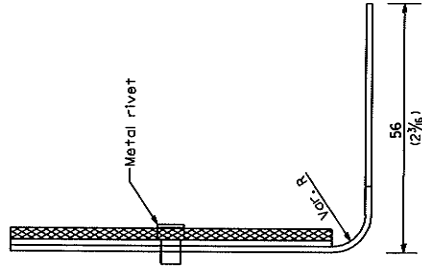

REFLECTOR MARKER TYPE A

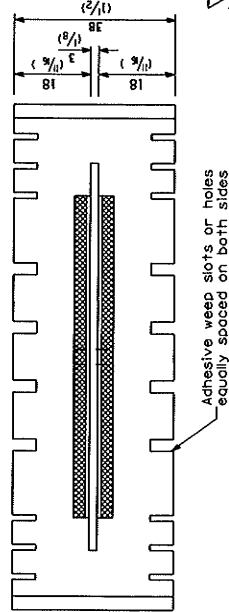
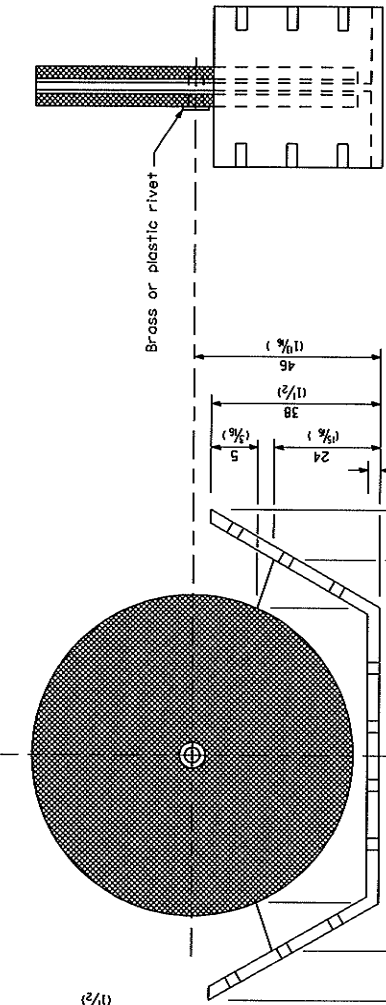
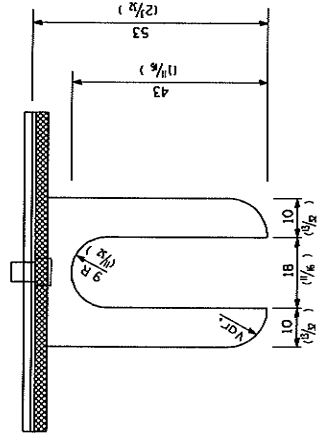

Adhesive weep slots or holes
equally spaced on both sides

All dimensions are in millimeters (inches)
unless otherwise shown.

DATE	REVISIONS
1-1-01	Revised signature block.
1-1-00	New Standard

REFLECTOR MARKER TYPE B

Illinois Department of Transportation
 APPROVED JANUARY 1, 2001
 ENGINEER OF OPERATIONS
 APPROVED JANUARY 1, 2001
 ILLINOIS DEPARTMENT OF TRANSPORTATION

REFLECTOR MARKER AND
MOUNTING DETAILS
(Sheet 1 of 3)
STANDARD 635011-01

Min. reflective area
4184 mm² (6 1/2 Sq. in.)
each side. May be
rectangular or slight
trapezoid.

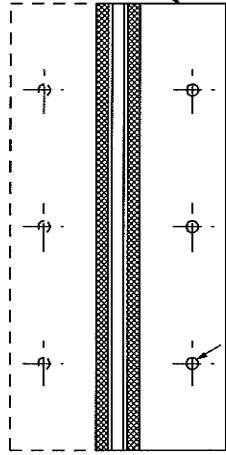
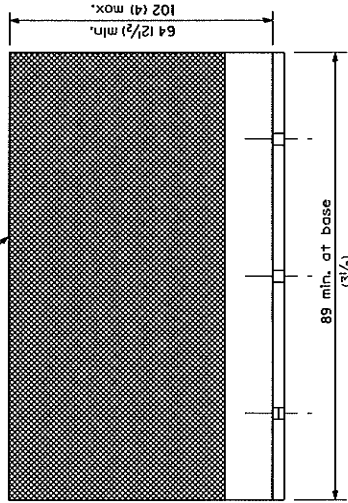

Minimum total area of
base 4516 mm² (7.0 Sq. in.)

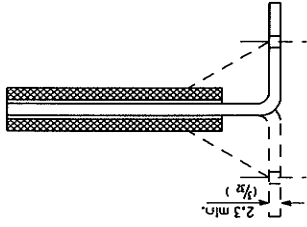

Cross section may be "T",
or "L" shaped and may have
side supports at ends.

REFLECTOR MARKER TYPE C

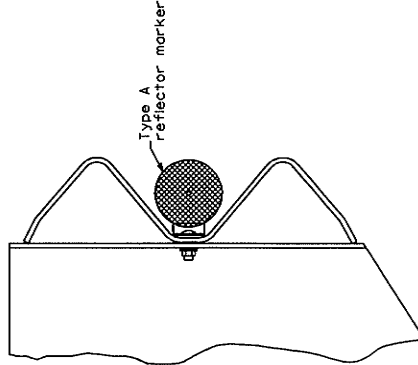

TYPICAL MOUNTING WITH REFLECTOR

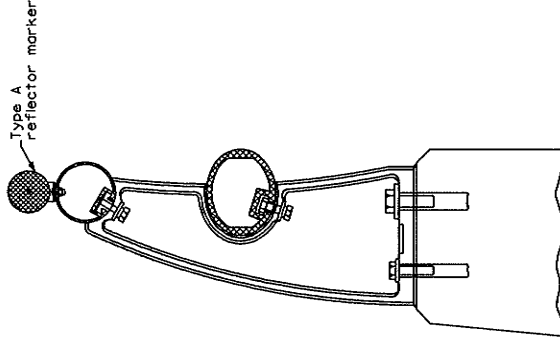

TYPICAL MOUNTING DETAIL
FOR BRIDGE RAIL REFLECTOR

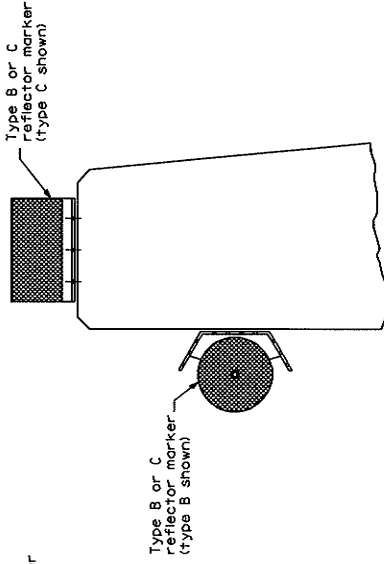

TYPICAL MOUNTING DETAIL
FOR BARRIER WALL REFLECTOR

All dimensions are in millimeters (inches)
unless otherwise shown.

Illinois Department of Transportation
APPROVED: [Signature] JANUARY 1, 2001
ENGINEER OF OPERATIONS
APPROVED: [Signature] JANUARY 1, 2001
ENGINEER OF DESIGN AND ENVIRONMENT

REFLECTOR MARKER AND
MOUNTING DETAILS
(Sheet 2 of 3)

STANDARD 635011-01

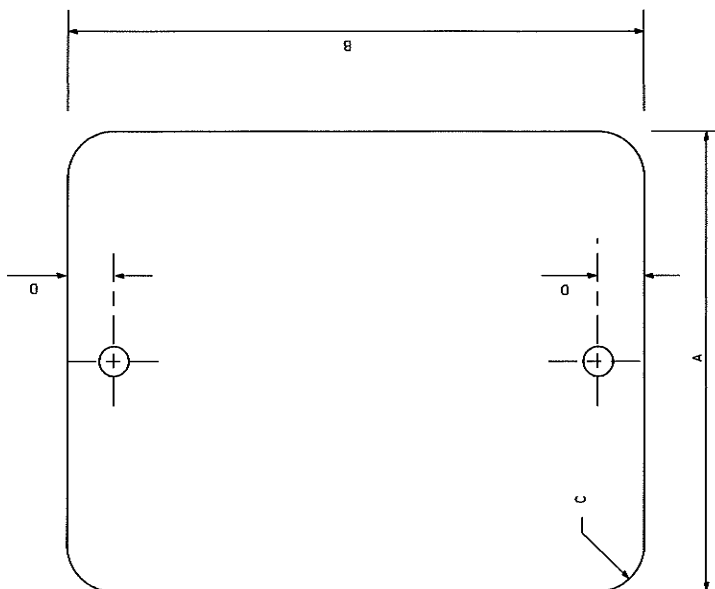

STANDARD TERMINAL MARKER

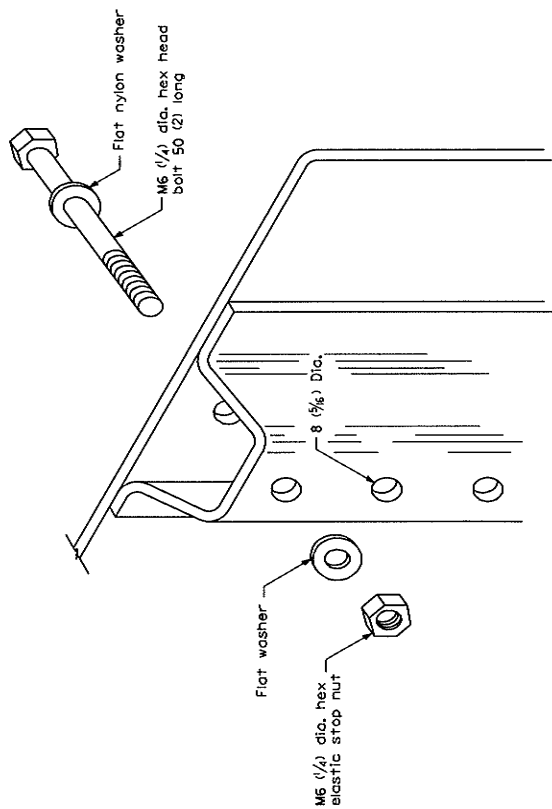

DETAIL OF MOUNTING TERMINAL MARKER TO POST

SIGN SIZE	DIMENSIONS			
	A	B	C	D
305x406 (12x16)	305 (12.0)	406 (16.0)	38 (1.5)	50 (2.0)

All dimensions are in millimeters (inches) unless otherwise shown.

REFLECTOR MARKER AND MOUNTING DETAILS

(Sheet 3 of 3)

STANDARD 635011-01

Illinois Department of Transportation APPROVED ENGINEER OF OPERATIONS APPROVED ENGINEER OF DESIGN AND ENVIRONMENT	JANUARY 1, 2001	ISSUED 1-1-2000
	<i>[Signature]</i>	APPROVED JANUARY 1, 2001

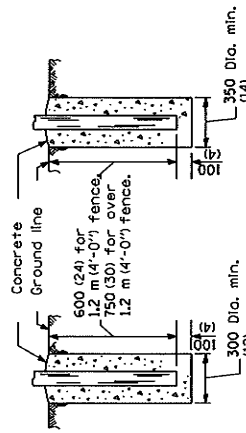

FOOTING FOR LINE POST
FOOTING FOR GATE & TERMINAL POST

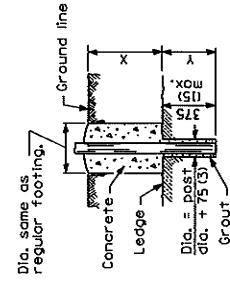

FOOTING FOR POST IN ROCK LEDGE

GENERAL NOTES

Pull posts shall be placed at locations determined by the Engineer. They shall be placed at 200 m (660') intervals between posts to which the ends of the fabric are clamped or midway between such posts when the distance is less than 400 m (1320') and greater than 200 m (660').

X + Y shall not exceed 600 mm (24"), 750 mm (30") or 900 mm (36") for 150 mm (6"), 225 mm (9"), 380 mm (15"), or 525 mm (21") Y, 375 mm (15"), and the post shall be shortened as required. When X exceeds 225 mm (9"), 380 mm (15"), or 525 mm (21"), Y shall be decreased correspondingly.

All dimensions are in millimeters (inches) unless otherwise shown.

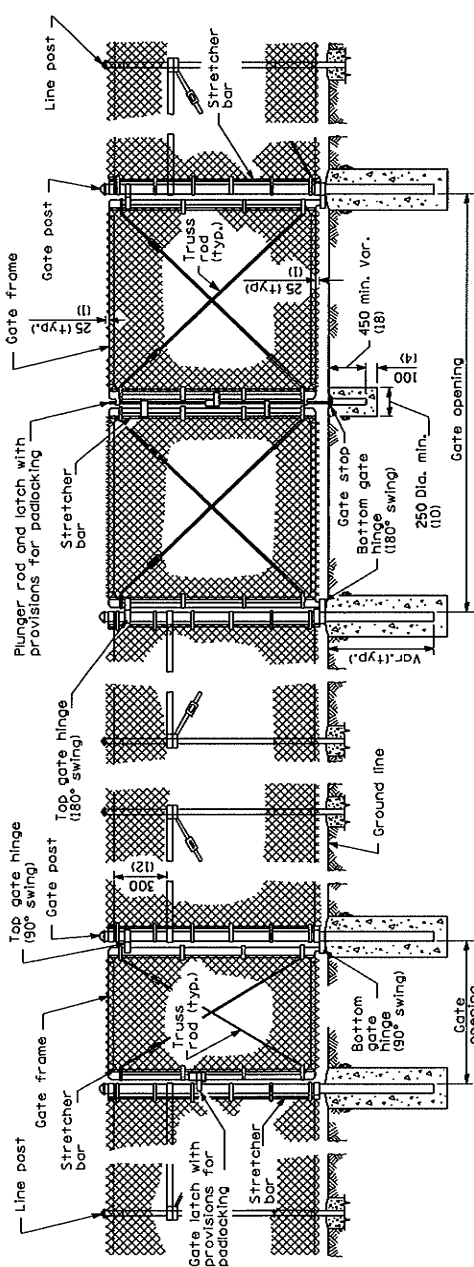

PEDESTRIAN GATE ARRANGEMENT

VEHICLE GATE ARRANGEMENT

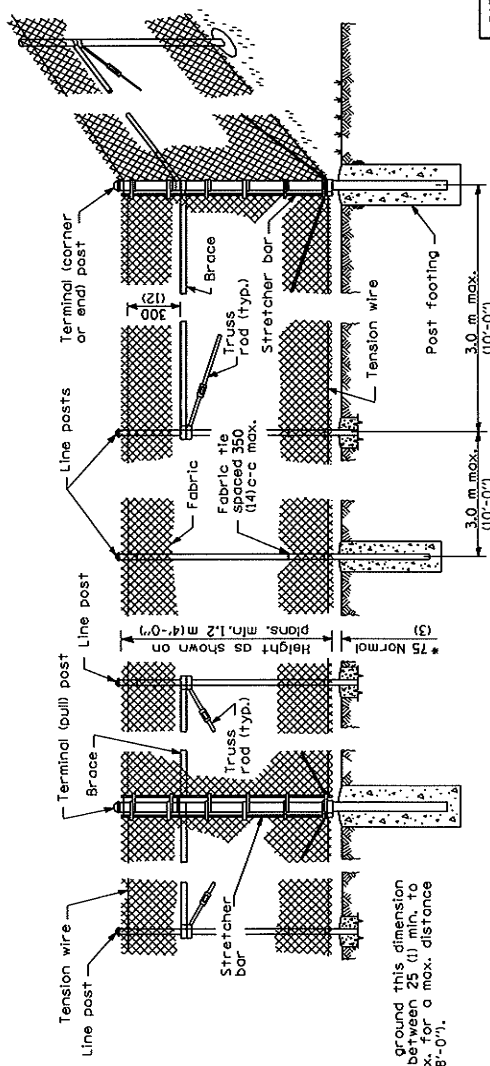

PULL POST ARRANGEMENT

LINE POST ARRANGEMENT

CORNER OR END POST ARRANGEMENT

DATE	REVISIONS
1-1-99	Rev. "plans" to "plans" in LINE POST ARRANGEMENT.
1-1-97	Renum. Standard 2168-12. Rev. top and bottom salvage type.

Illinois Department of Transportation
 ISSUED 1-1-97
 PASSED January 1, 1999
 ENGINEER OF PLANS AND PROCEDURES
 APPROVED January 1, 1999
 ENGINEER OF DESIGN AND CONSTRUCTION

CHAIN LINK FENCE
 STANDARD 664001-01
 (Sheet 1 of 3)

* On uneven ground this dimension may vary between 25 (1) min. to 125 (5) max. for a max. distance of 2.4 m (8'-0").

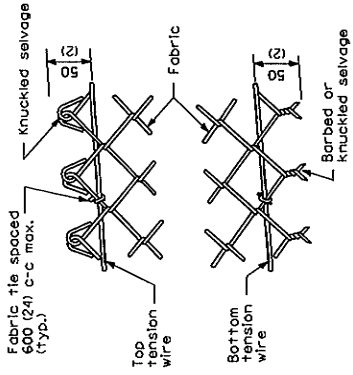

**METHOD OF TYING
FABRIC TO TENSION WIRES**

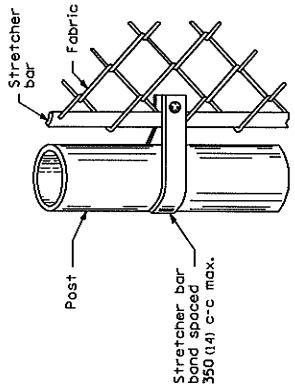

**METHOD OF FASTENING
STRETCHER BAR TO POST**

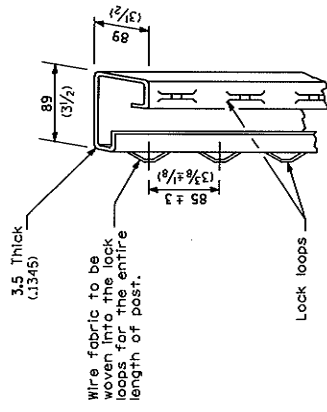

**ROLL FORMED SECTION OF
TERMINAL & GATE POST**

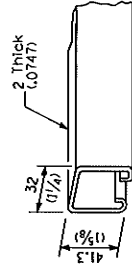

**ROLL FORMED
SECTION OF BRACE**

Section	Kg/m (lbs./ft.)
Pipe Type A 48.3 O.D. (1.90)	4.05 (2.72)
Pipe Type B 48.3 O.D. (1.90)	3.39 (2.28)
Pipe Type C 48.3 O.D. (1.90)	3.36 (2.26)
H 47.6x41.3 (1.875x1.625)	4.05 (2.72)
□	2.38 (1.60)
1	3.42 (2.30)

TERMINAL POST		Kg/m (lbs./ft.)
Section		
Pipe Type A 60.3 O.D. (2.375)	5.43 (3.65)	
Pipe Type B 60.3 O.D. (2.375)	4.63 (3.11)	
Pipe Type C 60.3 O.D. (2.375)	4.60 (3.09)	
Roll Formed 89.0x89.0 (3 1/2 x 3 1/2)	See detail	
Sq. Tubing 63.5x63.5 (2 1/2 x 2 1/2)	6.43 (4.52)	

HORIZONTAL BRACES		Kg/m (lbs./ft.)
Section		
Pipe Type A 42.2 O.D. (1.66)	3.38 (2.27)	
Pipe Type B 42.2 O.D. (1.66)	2.72 (1.83)	
Pipe Type C 42.2 O.D. (1.66)	2.71 (1.82)	
H 33.3x38.1 (1.31x1.5)	3.35 (2.25)	
Roll Formed 41.3x31.8 (1 7/8 x 1 1/4)	See detail	

GRATE FRAMES		Kg/m (lbs./ft.)
Section		
Pipe Type A 42.2 O.D. (1.66)	3.38 (2.27)	
Pipe Type B 42.2 O.D. (1.66)	2.72 (1.83)	
Pipe Type C 42.2 O.D. (1.66)	2.71 (1.82)	

Gate Opening	Pipe Type A		Pipe Type B	
	Size (O.D.)	Kg/m (lbs./ft.)	Size (O.D.)	Kg/m (lbs./ft.)
Up to 1.2 (4)	60.3 (2.375)	5.43 (3.65)	60.3 (2.375)	4.63 (3.11)
Over 1.2 to 2.5 (4) (8)	73.0 (2.875)	8.62 (5.79)	73.0 (2.875)	6.91 (4.54)
Over 2.5 to 3.6 (8) (12)	89.0 (3.5)	11.28 (7.58)	89.0 (3.5)	8.49 (5.70)

GATE POSTS *

* The 89.0 x 89.0 (3 1/2 x 3 1/2) roll formed section as detailed may be used as gate posts for single gate up to 1.8 m (6') and double gate up to 3.6 m (12').

All dimensions are in millimeters (inches) unless otherwise shown.

PASSED JANUARY 1, 1989
 Illinois Department of Transportation
 ENGINEER OF FACTORY PROCEDURES
 APPROVED JANUARY 1, 1989
 ENGINEER OF DESIGN AND ENVIRONMENT

CHAIN LINK FENCE

STANDARD 664001-01

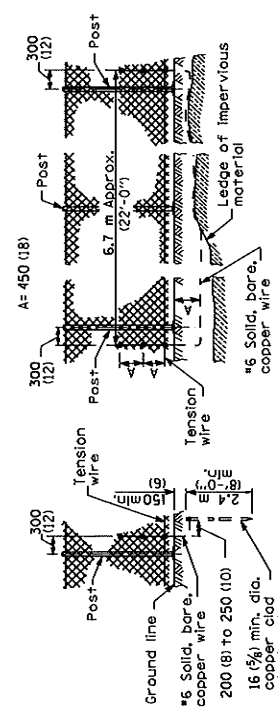

STANDARD GROUND

COUNTERPOISE GROUND (ALTERNATE)

PROTECTIVE ELECTRICAL GROUNDS

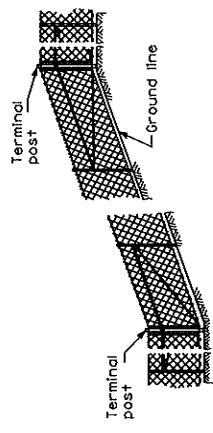

INSTALLATION ON SLOPES

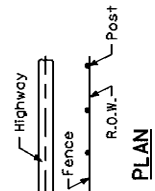

PLAN



When fence line has a change in direction of 15° or more, a terminal post shall be placed as shown above. Where angle is less than 15° and existing conditions require a terminal post, they shall be placed as directed by the Engineer.

INSTALLATION AT CORNERS

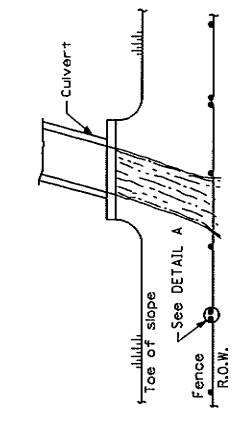

PLAN AT STREAM CROSSING

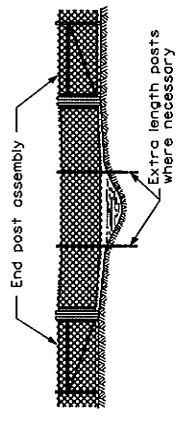

The chain link fabric shall be replaced by barbed wire strands at 300 (12) maximum centers between the double posts shown on DETAIL A when shown on the plans.

ELEVATION INSTALLATION OVER STREAM

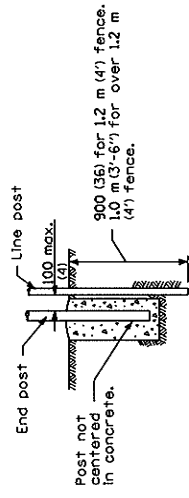

DETAIL A

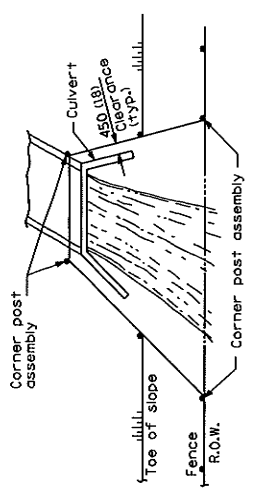

PLAN AT HEADWALL

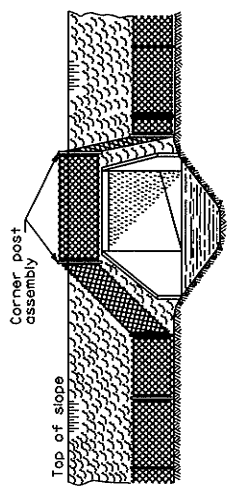

When the width of the culvert makes it necessary to anchor a post to the top of the culvert, a cast iron shoe or other device approved by the Engineer shall be used.

ELEVATION INSTALLATION AROUND HEADWALL

All dimensions are in millimeters (inches) unless otherwise shown.

Illinois Department of Transportation
 PASSED JANUARY 1, 1989
 ENGINEER OF POLICE AND PROCEDURES
 APPROVED JUNE 1, 1989
 ENGINEER OF DESIGN AND ENVIRONMENT

CHAIN LINK FENCE
 (Sheet 3 of 3)
STANDARD 664001-01

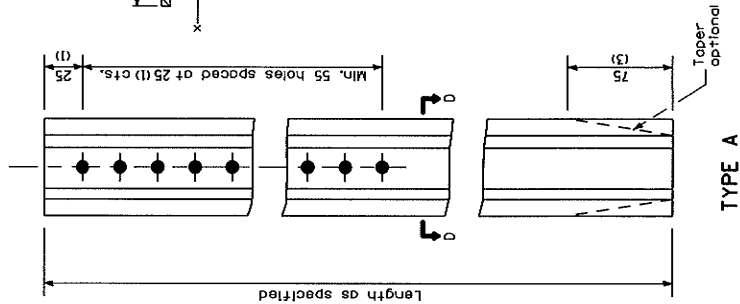

TYPE A

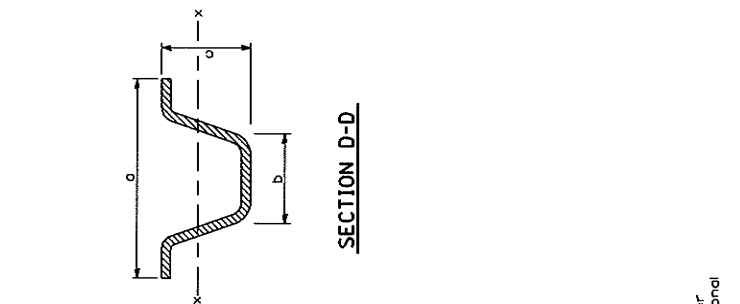

TYPE B

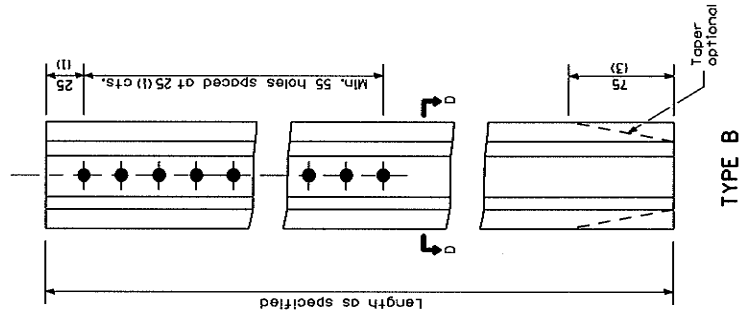

TYPE C

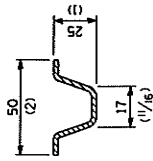

SECTION E-E
1.67 kg/m
Steel - (112 lbs./ft.)

	c	b	c	Sx-x ³ mm ³ (in. ³)	kg/m (lbs./ft.)
TYPE A	Steel (3 3/8)	32 (1 1/4)	37 (1 1/2)	3,654 (0.223)	2.98 (2.00)
	Aluminum (3 7/8)	41 (1 5/8)	48 (1 7/8)	7,128 (0.435)	1.34 (0.90)
TYPE B	Steel (3 3/8)	32 (1 1/4)	38 (1 1/2)	5,598 (0.341)	4.46 (3.00)
	Aluminum (4 5/8)	57 (2 1/4)	60 (2 3/8)	14,552 (0.888)	1.93 (1.30)

GENERAL NOTES

Dimensions shown for cross sections are minimum.

All holes are 10 mm (3/8") diameter.

Sx-x is the minimum section modulus about the x-x axis of the post as shown. For posts in which holes are punched or drilled for more than half their length, Sx-x shall be computed for the net section.

All dimensions are in millimeters (inches) unless otherwise shown.

DATE	REVISIONS
1-1-97	Renum. Standard 2350-4.
6-15-94	Added Metric.

METAL POSTS FOR SIGNS, MARKERS & DELINEATORS

STANDARD 720011

Institute of Transportation Engineers
 PASSED JANUARY 1, 1997
 ENGINEER OF SAFETY AND PROCEDURES
 APPROVED BY JANUARY 1, 1997
 ENGINEER OF DESIGN AND INSPECTION

ISSUED 1-1-97

APPENDIX A
FAA SPECIFICAITONS

1. SUBMITTALS AND BRAND NAME USAGE

Each product required for use in the contract drawings and specifications must meet the actual minimum needs of the Government as demonstrated in the salient (prominent, important) characteristics for that product. If a brand name product is used in the drawings or specifications, it should be regarded as "known acceptable source" (i.e., a product that meets the actual minimum needs, and demonstrates the appropriate salient characteristics). The product used can be identical or equal to the brand name product or known acceptable source in meeting the salient characteristics, but it need not exceed the actual minimum requirements. Any brand name product or known acceptable source mentioned will, however, not be required for use in order to comply with the specification or drawing unless those documents make it clear that the brand name product is required, and substitution is prohibited. See paragraph 1A.4 or Specification FAA-GL-918C. IN THE FOLLOWING SUBMITTALS SPECIFICATIONS, WHERE PARAGRAPHS ARE REFERENCED WITHOUT DOCUMENT REFERENCE, THE PARAGRAPHS ARE OF SPECIFICATION FAA-GL-918C.

A. Submittals for proposed substitutions.

Each product that a Contractor wishes to use that is not a known acceptable source, must be approved before use by the Contracting Officer or the Contracting Officer's designee. To gain approval, the contractor must submit documents and/or samples that will demonstrate that the product clearly will meet the Government's minimum needs, and demonstrates appropriate salient characteristics. All submittals proposing substitutions must be in writing.

The Contractor shall furnish submittals for any and all items that are proposed to substitute for the following items approved in Specification FAA-GL-918C.

- (1) Splicing Connectors. See paragraphs 13A.6c and 16F.6d
- (2) Power Cable Splicing Kits. See paragraph 13A.6.
- (3) Control Cable Splicing Kits. See paragraphs 16F.6c thru 16F.6d
- (4) NOT USED
- (5) Geotextile. See Paragraph 2B.3a. The minimum requirement values of Geotextile physical properties are tabulated in Paragraph 2B.3a(2). Submittals must include values of these properties for the substitute Geotextile.
- (6) NOT USED
- (7) Lightning Protection Equipment. See paragraph 16A.18
- (8) NOT USED
- (9) NOT USED
- (10) Screw Anchor Foundations. See Paragraph 13D9 for submittal requirements.
- (11) NOT USED
- (12) Cable connectors. See paragraph 23 of these special Specification

- (13) Frangible Couplings. See paragraph 24 of these special Specification
- (14) NOT USED

C. Long lead items.

THE CONTRACTOR SHALL BE AWARE THAT SOME MATERIAL THAT REQUIRE SUBMITTALS ARE "LONG LEAD ITEMS!" THESE SUBMITTALS MUST BE SUBMITTED (ANYTIME AFTER AWARD) FOR APPROVAL AS SOON AS POSSIBLE!

2. DISPOSAL OF REFUSE:

Conduct cleaning and disposal operations to comply with codes, ordinances, regulations and anti-pollution laws. The Contractor shall make a special effort to keep the construction area neat and orderly. It is the Contractor's responsibility to provide containers for debris and deposit and schedule collections and disposal of debris.

3. LOCATION OF UNDERGROUND UTILITIES:

Prior to beginning any excavation, the Contractor shall contact the Airport Management, local FAA maintenance personnel and utility companies to have underground utilities located and staked out.

4. BURIED GUARD WIRE.

The following paragraph supplements and supersedes Paragraph 16A.4e of Specification FAA-GL-918C.

- e. Buried Guard Wire. Buried cables (including armored cables) not completely enclosed in ferrous conduit, shall be protected by a bare copper guard wire. Unless specified otherwise, or shown otherwise on the drawings, the guard wire shall be #1/0 AWG. Embed the guard wire in the soil at least 10 inches directly above and parallel to the cables being protected. Where the width of the run of cables or ducts does not exceed 3 feet, install one guard wire centered over the cable or duct run. Where the cable or duct run is more than 3 feet wide, install two guard wires. Space the two guard wires at least 12 inches apart, and 12 to 18 inches inside the outermost wires or outermost edges of the duct. Weld the guard wire exothermically to a grounding electrode at each end, and to grounding electrodes at approximately 90-foot intervals. The spacing between the grounding electrodes shall vary by 10 to 20 percent, to prevent resonance.

The following paragraph supplements and supersedes Paragraph 16F.3f of Specification FAA-GL-918C.

- f. Buried Guard Wire. Unless specified otherwise, all direct-earth burial power, control, and coaxial cables shall include the installation of #1/0 bare copper ground wire per Paragraph 16A.4e above.

5. AIR TRAFFIC CONTROL SAFETY:

The Construction Contractor shall perform all work in a manner which does not conflict with, or adversely affect, the air traffic operational environment. In the event of any actual or potential conflicts, air traffic activities shall have priority over all construction activities.

The Contractor shall maintain a heightened degree of sensitivity to airport operations, security, project scheduling and interim runway/taxiway closures which may be required during construction, including other ancillary tasks associated while working at the airport.

6. NIGHT WORK:

In general, some work tasks required in this project may be performed at night, weekends and/or around the clock to minimize the effect on air traffic operations. The specific tasks to be accomplished at night shall be determined by FAA (air traffic and airway facilities) and the airport operations personnel. The contractor shall provide 48 hour prior notification to the FAA Resident Engineer before proceeding with any of the accelerated work tasks.

7. **RUNWAY ENDS AND BENCHMARKS:**

The threshold elevation of the existing end of Runway 33 centerline is indicated on the construction drawings.

8. **FACILITY LAYOUT SURVEY:**

The Contractor shall have all the navaids facilities staked out by a registered Surveyor.

9. **CRUSHED ROCK:**

All crushed rock and or aggregates shown on the construction drawings except otherwise specified shall be per paragraph 2B.3c(1) of Specification FAA-GL-918C.

10. **GEOTEXTILE:**

All crushed rock surfaces (roads, turnaround and parking areas, walkways, facility work areas, etc.) shall be underlain with Geotextile per Paragraph 3a, Section 2B, Specification FAA-GL-918C, whether shown on the drawings or not.

11. **LIGHTNING ARRESTER:** NOT USED

12. **CONTROL CABLE SHIELD GROUNDING:**

Control cable shield shall be grounded at each end of each cable run. This requirement overrides Specification FAA-GL-918C, Paragraph 16F.8a(1) and Specification FAA-GL- 840B, Paragraph 16F .8a(1).

13. **MATERIAL SAFETY DATA SHEETS (MSDS):**

The Contractor shall give the Resident Engineer a copy of the MSDS for every building material for which an MSDS is issued.

14. **GROUNDING SUPPLEMENT.**

A. **Equipment, Structures and Conduits.**

(1) All metallic non-current carrying parts of electrical equipment and supporting structures installed under this contract and used for either power or control, shall be grounded with green insulated copper equipment grounding conductors, shall be sized according to the National Electrical Code and larger, if so specified herein or on the drawings.

(2) The equipment grounding conductor shall be connected to the grounded conductor (neutral) only at the main service disconnect means. The equipment grounding conductor shall be installed in the same conduit as its related branch and feeder conductors and shall be connected to the ground bus in the branch or distribution panelboard.

(2) Where there are parallel feeders installed in more than one raceway, a full-sized equipment grounding conductor shall be installed in each raceway. The metallic conduit housing the equipment grounding conductor shall also be electrically continuous forming a parallel path to the equipment grounding

conductor. Under no circumstances shall this conductor be omitted from the electrical system, nor shall any separate grounding system such as the signal ground, be used for an alternate grounding system or an alternate path to the grounding electrode. All connections to the equipment to be grounded shall be made with a ground connector specifically intended for that purpose. Connecting screws or mounting bolts and screws are not suitable for use as grounding connections. All ground lugs shall be of a non-corrosive material suitable for use as a grounding connection, and must be compatible with type of metal being grounded.

(4) Unless otherwise specified, control equipment enclosures, pull boxes and raceways shall be grounded as above for power wiring and the conductor shall be connected to an equipment grounding conductor used for power or control which is ultimately carried to ground through the entrance service switch.

B. Duct Bank Counterpoise.

The Contractor shall install a # 1/0 bare grounding/counterpoise wire 10 inches above all duct banks installed under this contract. The conductor shall be terminated at each end to existing facility counterpoise or grounding electrodes or to a new grounding electrode where none exists. This shall be done whether it is shown on the drawings or not and is in addition to the #6 AWG equipment grounds per Paragraph 4.(A).2 above.

C. Raceway Grounding.

When surface metal raceways, wireways or cable tray systems are installed, a separate copper conductor shall be installed in the raceway and shall be properly bonded to each section. Unless otherwise indicated, the minimum size ground conductor shall be #6 green insulated copper.

15. **GROUNDING ELECTRODE.** The following specifications supersede Paragraph 16A.4c of Specification FAA-GL-918C.
 - c. **Grounding Electrode.** Grounding electrodes (rods) shall be copper clad steel, 3/4-inch by 10 feet, except where otherwise specified. The top of the grounding electrode shall be a minimum of 12 inches below finished grade. Conductors shall be attached to electrodes with exothermic welds only, except where fire or explosion hazards exist, as near existing fuel tanks. Where such hazards exist, hydraulically crimped connections will be permitted as specified below.
16. **ELECTRODE GROUND TESTING.** The following specifications supersede Paragraph 16A.4h of Specification FAA-GL-918C.
 - h. **Testing.** Electrode grounds shall be tested for resistance at each location. Resistance to ground for each grounding location shall be 10 ohms or less. If this value is not achieved with the grounding electrodes as shown on the drawings, additional grounding electrodes spaced at least 6 feet apart, or electrode extensions of the same construction and diameter, shall be installed until the resistance value does not exceed the maximum of 10 ohms. A tabulated report of the final resistance value at each location shall be provided to the Resident Engineer.
17. **AIR TERMINAL BRACE.** The following specifications supersede Paragraph 16A.18c of Specification FAA-GL-918C.
 - c. **Air Terminal Brace Assembly.** The air terminal brace assembly for a 36" air terminal shall be a 24"-long galvanized tripod assembly, with legs adjustable to accommodate any roof slope. Cat. No. 82 meets these specifications.

18. GROUND ROD CLAMPS. Paragraph 16A.18k, Ground Rod Clamps, of Specification FAA-GL-918C, is deleted.
19. CONTROL CABLE. The following specifications supplement Paragraph 16E of Specification FAA-GL-918C.
- Specification. Control cable shall be either:
- REA Specification PE-39 cable meeting all the requirements of Section 16E, or
 - REA Specification PE-89 cable (having foamed polyethylene or propylene conductor insulation with a solid skin of the same material), meeting all requirements of Specification FAA-GL-918C Section 16E except the REA Specification PE-39 requirements.
20. FACILITY AC SURGE ARRESTER. NOT USED
21. CONSTRUCTION SAFETY PLAN:
- The Construction Safety Plan is as shown on the plans.
22. AIRPORT CONSTRUCTION ACCESS:
- The Contractor shall use the access route shown on the safety plan unless directed otherwise.
23. SPLICES:
- The Contractor shall provide sufficient continuous length of cable to avoid splices. However some of the long duct pulls will require splices in the electric handholes. No resin older than the date on the package shall be used for any splice
24. TESTING OF 600V POWER CABLE:
- After installation, 600V power cables, splices, and terminations shall test positive for electrical continuity, test free of grounds, and shall have a minimum of 50 megohms between conductors and from conductors to ground. The Contractor shall perform the test at not less than 500 volts DC. Any measured insulation resistance value less than 50 megohms shall be cause for rejection of the installation, and the installation shall be replaced or repaired to meet the minimum 50 megohms standard at no additional cost to the government.
25. MALS PAR-38 LAMPS
- Specifications. The following specifications override Paragraph 13A.5. The Contractor shall furnish ninety PAR-38 halogen incandescent spot lamps. The lamps shall be rated by the manufacturer to have 120-watt power, approximately 1900 lumens and 25000 center beam candlepower (CBCP), and 3000 hours lamp life at 120 volts. Sylvania lamps of lamp designation 120PAR/CAP/SPL/SP and NAED (Vendor I.D. No.) code 14856 meet these specifications. If the Contractor intends to furnish lamps other than Sylvania No. 14856, the Contractor shall submit to the Contracting Officer the substitute lamp's candlepower distribution curve and manufacturer's technical data sheets demonstrating that the substitute meets the power, brightness, and lamp life and lumen maintenance criteria of the above specifications. The Contractor shall also furnish a sample lamp, and shall demonstrate that it will fit the lamp aiming device supplied with the MALSR.
- B. Application. The Contractor shall install 45 of these lamps on the light structures. The remaining 45 lamps shall be delivered to the Resident Engineer for use as spares. The installed lamps shall be aimed vertically to the aiming angles specified on the drawings.

- C. PAR-38 LAMPHOLDER SOCKET RETENTION SCREWS. If DME Corp. MALS equipment is furnished by either the FAA or the contractor, the contractor shall inspect the PAR-38 lampholders. It is probable that the heads of the socket retention screws furnished with the lampholders are too wide to fit into the socket recesses. If they are, the contractor shall furnish stainless steel 6-32 x 1 1/4" socket head cap screws to install the sockets in the lampholders. Two cap screws are required per PAR-38 lampholder.

26. CONTRACTOR-FURNISHED CABLE CONNECTORS.

The Contractor shall furnish all the cable connectors to be applied under this contract. All cable connectors shall meet the requirements of FAA Advisory Circular AC 150/5345-26B, Specification for L-823 Plug and Receptacle, Cable Connectors, hereinafter called the AC. In the following specifications, Type, Class, and Style are as defined in the AC, namely:

- ◆ Type II 2 conductor, 20 ampere, 600 volt
- ◆ Class B Field-attached to conductor(s)
- ◆ Style 4 Plug connector, Type II, Class B
- ◆ Style 11 Receptacle connector, Type II, Class B

- A. For PAR-56 Light Upper Cable Assemblies. For each upper cable assembly of the eighteen (18) PAR-56 MALS threshold lights, apply a Style 4 plug connector designed to fit two 1/C #12 stranded Type THWN cables (.137" cable O.D.). Connectors Elastimold Cat. No. 90P-S6 and Crouse-Hinds Cat. No. 823KS-0PS6 are among connectors meeting these specifications. The Contractor shall furnish twenty-two (22) each of the plug connectors.
- B. For PAR-38 Light Upper Cable Assemblies. For each upper cable assembly of the forty-five (45) PAR-38 MALS white lights, apply a Style 4 plug connector designed to fit two 1/C #14 stranded Type THW cables (.17" cable O.D.). Connectors Elastimold Cat. No. 90P-A8 and Crouse-Hinds Cat. No. 823KS-0PA8 are among connectors meeting these specifications. The Contractor shall furnish fifty (50) each of the plug connectors.
- C. For Lower Cable Assemblies. For each lower cable assembly of the two PAR-56 MALS threshold bar outboard lights, and of the MALS LIR light bar structures, apply a style 11 receptacle connector designed to fit two 1/C#10 stranded or solid type U.S.E. cables (20" cable O.D.). Connectors Elastimold Cat No. 90R-B6 and Crouse-Hinds Cat.No. 823KS-ORB6 are among connectors meeting these specifications. The Contractor shall furnish seventy two (72) each of the plug connectors.

If the Contractor intends to furnish substitute cable connectors, the Contractor shall submit to the Contracting Officer, catalog cuts demonstrating that the substitute connectors meet the AC requirements, are of the specified styles, and fit the specified cables. At the End of construction, The Contractor shall turn all spare connectors over to the Resident Engineer, who will deliver them to the FAA maintenance personnel as spares.

27. CONTRACTOR-FURNISHED FRANGIBLE COUPLINGS

The following specifications supersede Paragraph 16A.20a of Specification FAA GL- 918C.

The Contractor shall furnished all the frangible couplings to be applied under this contract.

All frangible couplings shall be 2" diameter cast aluminum couplings having a hexagonal clamping ring. The coupling shall accommodate 2" diameter EMT conduit. The frangible couplings shall meet the requirements of either Military Specification MS -17814-1, or of FAA Drawing C-6046. The straight-thread Multi Electric Cat No. 961-A frangible coupling is among couplings meeting MS-17814-1. The tapered-thread Multi-Electric CAT. No. 961-1AT frangible coupling is among couplings conforming to FAA Drawing C-6046. If the Contractor intends to furnish substitute frangible couplings, the Contractor shall submit to the Contracting Officer, catalog cuts demonstrating that the substitute couplings meet the specifications herein. The Contractor shall furnish at least 70 each of the frangible couplings. The Contractor shall turn all spare frangible couplings over to the Resident Engineer who will deliver them to FAA maintenance personnel as spares.

28. **LIR TOWERS**

- A. **Epoxy Resin**: Chemlock 304-1 and 304-2, epoxy resin and hardener, respectively are available from :

Lord Corp. Chemical Product Group
2000 W. Grandview Blvd.
Erie, Pennsylvania 16509
Tel: (814) 868-3611

Jaiquith Industries, Inc.
E. Brighton and Glen Avenues
Syracuse, New York 13205
Tel: (315) 478-5700

- B. **LIR Tower Test**: The Contractor shall demonstrate to the satisfaction of the Resident Engineer that the installed tilting LIR towers will tilt down smoothly, without undue force and without binding. The towers shall be adjusted as necessary and testing repeated until accepted by the Resident Engineer.

29. **ELECTRIC POWER COMPANY COORDINATION**: The Contractor shall coordinate with Commonwealth Edison Electric Company on the establishment of electric service. Point of contact is Katie Oliva at Tel. No. 847-608-2338.
30. **RUNWAY SHUTDOWN**: Runway shutdown shall be coordinated with the Airport Director and FAA-RFD-SSC Manager. Notice shall be given no less than 48 hours prior to shutdown. FAA (POC) is Dan Geist at Tel. No. 815-509-3200.
31. **AIRPORT COORDINATION**: The FAA Contractor shall fully coordinate their work with the FAA maintenance and Electronic installation personnel and the Airport authority. All coordination shall be done through the Resident Engineer.
32. **STEEL SIDING**. The following paragraph supplements and supersedes Paragraph 13E.8 of Specification FAA-GL-918C.
- 13E.8 **STEEL SIDING**. Furnish and install steel siding panels and accessories in accordance with manufacturer's instructions and the following material specifications.
- a. **Steel Sheet and Coating**. The siding is made from roll formed 0.0172 inch (nominal) thick hot-dipped galvanized steel complying with ASTM A653 and having minimum yield and ultimate strength of 33,000 and 55,000 psi respectively. The coating is polyvinyl chloride, 4 mils dry film thickness. Unless otherwise specified on the drawings, the outside finish color is white.
- b. **Siding Meeting Specifications**. Coated steel siding by Rollex Corporation, Elk Grove Village, Illinois is among products meeting these specifications. Substitutes require submittals per Paragraph 1A.4 above.
33. **Fluorescent Light Fixtures and Ballasts**. Not used
34. **ANTI-SEIZE COMPOUND**. See Specification FAA-GL-918C, Paragraph 13A.2d(1) for anti-seize compound specification, and application to frangible EMT mountings. The Paragraph 13A.2d(1) requirements apply to all frangible EMT mountings under this contract. The contractor shall also apply anti-seize compound to all stainless steel hardware before assembling the hardware, and before tightening stainless steel nuts and bolts. This requirement applies to all stainless steel hardware applied to light bases and base plates, LIR structures, or anywhere else stainless steel hardware is used under this contract. The compound used shall be suitable for use on stainless steel, as witnessed by a message so stating on the container label. The compound shall be used in a quantity and in a way that precludes binding, galling, or any other mode of seizure of the stainless steel hardware.

PLEASE RECYCLE.

DEPARTMENT OF TRANSPORTATION
FEDERAL AVIATION ADMINISTRATION
GREAT LAKES REGION
CHICAGO, ILLINOIS

FAA-GL-918C
November 30, 1994

SPECIFICATION FOR CONSTRUCTION OF
TERMINAL NAVIGATIONAL
AID FACILITIES

TABLE OF CONTENTS

<u>DIVISION</u>	<u>TITLE</u>
1	GENERAL REQUIREMENTS SECTION 1A - SPECIAL CONDITIONS N.I.C. SECTION 1B - SAFETY ON AIRPORTS N.I.C.
2	SITE WORK SECTION 2A - EARTHWORK AND SITE IMPROVEMENTS N.I.C. SECTION 2B - CRUSHED AGGREGATE ROAD AND SITE SURFACING N.I.C. SECTION 2C - ASPHALT CONCRETE PAVEMENT N.I.C. SECTION 2D - TOPSOIL AND GRASS COVER N.I.C. SECTION 2E - MISCELLANEOUS SITE IMPROVEMENTS N.I.C.
3	CONCRETE SECTION 3A - CONCRETE FORMWORK AND REINFORCEMENT SECTION 3B - CAST-IN-PLACE CONCRETE N.I.C.
4	NOT REQUIRED
5	METALS SECTION 5A - MISCELLANEOUS METALS
6	CARPENTRY SECTION 6A - ROUGH CARPENTRY
7	NOT REQUIRED
8	NOT REQUIRED
9	FINISHES SECTION 9A - PAINTING
10	NOT REQUIRED
11	NOT REQUIRED

TABLE OF CONTENTS

(CONTINUED)

<u>DIVISION</u>	<u>TITLE</u>
12	NOT REQUIRED
13	SPECIAL CONSTRUCTION SECTION 13A - APPROACH LIGHT SYSTEMS SECTION 13B - INSTRUMENT LANDING SYSTEM SECTION 13C - VASI, REIL, AND PAPI SYSTEMS SECTION 13D - SCREW ANCHOR FOUNDATIONS SECTION 13E - MALSR AND ILS EQUIPMENT SHELTERS SECTION 13F - NEW GENERATION RVR SYSTEMS N.I.C.
14	NOT REQUIRED
15	NOT REQUIRED
16	ELECTRICAL SECTION 16A - BASIC METHODS AND MATERIALS SECTION 16B - 600-VOLT POWER CABLE FOR UNDERGROUND INSTALLATION SECTION 16C - 600-VOLT ARMORED POWER CABLE SECTION 16D - 5000-VOLT POWER CABLE N.I.C. SECTION 16E - CONTROL CABLE SECTION 16F - CABLE INSTALLATION

DIVISION 1 - GENERAL REQUIREMENTS
SECTION 1A
SPECIAL CONDITIONS

1A.1 SCOPE.

- a. This specification covers general requirements for construction of an Instrument Landing System (ILS) and Visual Guidance Lighting Systems. The complete ILS consists of several component facilities. The term visual guidance lighting systems covers lighting facilities. Refer to the solicitation package for types of facilities to be constructed. This specification includes requirements common to all facilities and requirements specific to individual facility types. In general, all parts of this specification covering construction required on project drawings and in other contract documents, are applicable to this contract.
- b. The contractor shall furnish all plant, labor, materials (except Government-furnished property), equipment, energy, transportation, and other services necessary to construct all elements of the systems required in the specifications, drawings, and other contract documents. Construction shall include all miscellaneous and incidental work necessary for a complete and operational system, whether or not such work is specifically shown or specified.

1A.2 GOVERNMENT-FURNISHED PROPERTY. Government-furnished property (GFP) is also known as Government-furnished material (GFM). Government-furnished property for this contract is shown on the Government-Furnished Property List. The Government-Furnished Property List is the sole contract document which validly identifies Government-furnished property under this contract. The contract drawings give little or no indication of which items are Government-furnished. To determine whether an item of equipment or other material is Government-furnished, see the Government-Furnished Property List. For Government-furnished property, the contractor shall provide for and pay for loading of this property at the storage location (location indicated on the Government-Furnished Property List) and transportation to, and unloading at, the job site.

1A.3 CONTRACTOR-FURNISHED MATERIAL. The contractor shall furnish all material under this contract per Paragraph 1A.1b, except the Government-furnished property identified on the Government-Furnished Property List. The instruction install on the drawings means furnish and install unless the item(s) to which the instruction applies is Government-furnished property included in the Government-Furnished Property List. The contractor shall be aware that certain materials to be furnished by the contractor, may be long-lead-time items. Therefore, the successful bidder should determine the availability of all material immediately after contract award, and initiate procurement action on long-lead-time items at the earliest possible date. To facilitate the use of this specification in procuring material and equipment, see the Material and Equipment Specification Index at the end of this section. Where the specifications mention material or equipment by brand, it is regarded as a known acceptable source, as it meets specifications.

1A.4 SUBMITTALS AND BRAND NAME USAGE.

- a. Introduction. Each product required for use in the contract drawings and specifications must meet the actual minimum needs of the Government as demonstrated in the salient (prominent, important) characteristics for that product. If a brand name product is used in the drawings or specifications, it should be regarded as a "known acceptable source" (i.e., a product that meets the actual minimum needs, and demonstrates the appropriate salient characteristics). The product used can be identical or equal to the brand name product or known acceptable source in meeting the salient characteristics, but it need not exceed the actual minimum requirements. Any brand name product or known acceptable source mentioned will, however, not be required for use in order to comply with the specification or drawing unless those documents make it clear that the brand name product is required, and substitution is prohibited. The following submittal procedure shall be followed in order to:
 - (1) Insure adherence to functional and quality standards in substitute contractor-furnished material.
 - (2) Inform the FAA of the contractor's plans to use certain material and equipment, e.g., splicing materials and tools, even if they are a known acceptable source.
- b. Definition. A submittal is a collection of information required by specifications, or by the Contracting Officer, presenting detailed information on:
 - (1) Material or equipment items the contractor proposes to use.
 - (2) Methods or plans of action which the contractor intends to employ in specific situations.
- c. Requirements. Submittal requirements are formally defined in a paragraph of the contract Special Specifications. Submittal guidance of varying extent is presented in this specification (FAA-GL-918C), as indicated in the Material and Equipment Specification Index at the end of this section. Each product that a contractor wishes to use that is not a known acceptable source, must be approved before use, by the Contracting Officer or the Contracting Officer's designee. To gain approval, the contractor must submit documents and/or samples that will demonstrate that that product clearly will meet the Government's minimum needs, and demonstrates appropriate salient characteristics. All submittals must be in writing. The Contracting Officer shall have the right to require submittals from the contractor where the contractor makes an unsolicited change proposal. The information presented in a submittal shall be sufficient to demonstrate that all specification requirements for the subject material, equipment, methods,

1A.4c

or plans, are met by the contractor's proposal. The informational materials may include documents such as shop drawings, sketches, calculations, data sheets, written plans of action, manufacturers' catalog cuts, brochures, and/or specification sheets. If the specifications or Contracting Officer requires actual samples of material or equipment, the contractor shall provide them. For any documentary submittal, the contractor shall submit four identical sets of documents.

- d. Submittal Review. When submitting before the Notice to Proceed date, the contractor shall send the submittal package(s) directly to the Contracting Officer. When submitting after contract work has begun, the contractor shall give submittal packages to the Resident Engineer, who will forward them promptly to the Contracting Officer. The Contracting Officer may personally evaluate the submittal, or request FAA engineers to evaluate it. In either case, the submittal will return directly from the Contracting Officer to the contractor, with the Contracting Officer's approval, approval with comments, or disapproval.
- e. Submittal Time Frame. To provide adequate time for document transmission and submittal review, the FAA reserves the right to take two weeks to complete a review, transmission date to transmission date. Terminal navi-gational aid contracts are brief contracts. The review process can therefore span a substantial portion of the contract period. For this reason:
- (1) The contractor is urged to initiate submittals as soon as feasible after contract award, and to expedite document transmission.
 - (2) The Contracting Officer and other reviewers (if any) will expedite reviews and document transmission insofar as feasible.

Maximum use of fast document transmission modes (e.g., fax, couriers, and overnight freight forwarders) is encouraged.

- f. Procurement Before Approval. The contractor is advised not to procure any item for which submittal approval is required but not yet granted. If approval is denied, the contractor will be prevented from installing the disapproved item(s). The contractor must transmit a new submittal package for the new items replacing the disapproved items, and must procure only approved items. The contractor shall take responsibility for the delivery and installation of any items installed before submittal approval is granted. The FAA reserves the right to discontinue field work on any item furnished without submittal approval. Procuring and/or installing material which is later disapproved could result in substantial losses of money and time for the contractor.

- 1A.5 PRE-CONSTRUCTION CONFERENCE. The contractor shall attend a pre-construction conference when required by the contracting officer or airport management. The contractor shall abide by all agreements reached at the conference regarding safety practices, ingress and egress routes to the site, maintenance of airport security (locking gates, etc.), deference to air traffic, and other operational procedures.
- 1A.6 COORDINATION. All coordination between the contractor and the airport management and local FAA personnel, shall be accomplished through the Resident Engineer.
- 1A.7 PROJECT DRAWINGS.
- a. Conflict Between Site Drawings and Standard Drawings. If any conflict should exist between site drawings (location-specific drawings) and standard drawings (drawings not referring to a particular location), the site drawings shall govern.
 - b. Drawings Referenced But Not Provided. Unless otherwise specified, drawings which are referenced on contract drawings, but which are not listed in the list of specifications and drawings, do not apply to the contract.
- 1A.8 TEMPORARY ELECTRICAL POWER. Unless otherwise specified, the contractor shall make all arrangements and pay all costs for temporary electrical power needed for construction of the facility.
- 1A.9 COMPLIANCE WITH LOCAL AND OTHER CODES. The contractor shall comply with standards (e.g., National Electrical Code) adopted by the contract documents, and with local and other codes. Where the requirements of the specifications and drawings exceed those of the adopted and local codes, the contractor shall comply with the requirements of the specifications and drawings.
- 1A.10 SANITARY FACILITIES. Sanitary facilities are not available at the work sites. The contractor shall provide temporary toilet facilities as required for his employees. The locations of the toilet facilities shall be where directed by the Resident Engineer.

MATERIAL AND EQUIPMENT SPECIFICATION INDEX

Does the paragraph include:

<u>Material or Equipment Specified</u>	<u>Relevant Paragraph(s)</u>	<u>Product(s) listed?</u>	<u>Submittal guidance?</u>
air conditioner	16A.17e	N	N
anti-seize compound	13A.2d(1) 13C.2b	Y Y	N N
cable			
600V power cable, DEB	Section 16B	N	N
600V armored power cable, DEB	Section 16C	N	Y
5,000V power cable, DEB	Section 16D	N	Y
clamp	13A.2d(2)	Y	N
control cable	Section 16E	N	Y
connector protection	16A.24	Y	N
end caps	16A.8	Y	N
splicing connectors			
power	13A.6c	Y	Y
power and control	16F.6	Y	Y
splicing kits			
MALS power	13A.6b	Y	Y
power and control	16F.6	Y	Y
circuit breakers	16A.14b&e	Y	N
conduit	16A.1 16A.3	N N	N N
door hardware for shelters	13E.4	Y	N
electrical coating	16A.25	Y	N
electrical enclosures and wireways	16A.15	N	N
electrical tape	16A.21	Y	N

MATERIAL AND EQUIPMENT SPECIFICATION INDEX (CONTINUED)

Does the paragraph include:

<u>Material or Equipment Specified</u>	<u>Relevant Paragraph(s)</u>	<u>Product(s) listed?</u>	<u>Submittal guidance?</u>
environmental equipment for shelters	16A.17	Y	N
exothermic welding kits	16A.4f	Y	Y
expansion couplings	16A.27	Y	N
fiber forms for concrete piers	3B.7b	Y	N
fire and arc proofing	16A.23	Y	N
framing, commercial metal	16A.26	Y	N
frangible couplings	16A.20	Y	N
fuses for switches	16A.13f	Y	N
geotextile	2B.3a	Y	Y
grounding electrode material	16A.4c	N	N
crimped connectors for	16A.4g	Y	Y
grounding conductor	16A.4d	N	N
heater	16A.17c	Y	N
heater timer unit (components)	16A.17d	Y	N
landscape fabric	2B.3b	Y	Y
lamp, MALS 120-watt	13A.5	Y	Y
lighting equipment for shelters	16A.17f	Y	N
	16A.17g	Y	N
lightning protection equipment	16A.18	Y	N
paint	9A	N	N
	13E.7	Y	N
panelboard	16A.14	Y	N
pre-stretched rubber tubing	16A.22	Y	N

MATERIAL AND EQUIPMENT SPECIFICATION INDEX (CONTINUED)

Does the paragraph include:

<u>Material or Equipment Specified</u>	<u>Relevant Paragraph(s)</u>	<u>Product(s) listed?</u>	<u>Submittal guidance?</u>
safety disconnect switches	16A.13	Y	N
screw anchor foundations	Section 13D	Y	Y
shelter steel siding	13E.8	Y	N
splicing connectors and kits	see under cable		
surge arrester	13F.7	Y	N
	16A.16	Y	Y
switches, safety	16A.13	Y	N
fuses for	16A.13	Y	N
tape	see electrical tape		
terminal strips for control cable	16A.19	Y	N
vent fan	16A.17a	Y	N
thermostat for	16A.17b	Y	N

DIVISION 3 - CONCRETE
SECTION 3A
CONCRETE FORMWORK AND REINFORCEMENT

3A.1 DESCRIPTION OF WORK. Extent of work is indicated on the drawings and by the requirements of this section.

3A.2 CONCRETE FORMWORK.

- a. Design of Forms. Forms shall conform to shapes, lines, and dimensions of the members shown on the plans, and shall be sufficiently tight to prevent leakage of mortar. They shall be properly tied together so as to maintain position and shape.
- b. Form Removal. Forms shall not be loosened or removed until the concrete members have acquired strength sufficient to support their own weight. No additional loads shall be placed on the concrete for at least 48 hours after placing.
- c. Form Ties. Form ties for concrete shall be of a type that will break back 1 1/2 inches from the concrete surface. Ties shall be removed to a minimum depth of 1 1/2 inches, and the surface patched.

3A.3 CONCRETE REINFORCEMENT.

- a. Materials. Reinforcement bars shall conform to "Specifications for Billet - Steel Bars for Concrete Reinforcement", ASTM A-615. All bars shall be intermediate grade deformed bars.
- b. Cleaning and Bending Reinforcement. At the time concrete is placed, metal reinforcement shall be free from rust scale or other coatings that will destroy or reduce the bond. All bent bars shall be bent cold. No bars partially embedded in concrete shall be field bent except as shown on plans.
- c. Placing Reinforcement. Metal reinforcement shall be accurately placed according to the plans, and adequately secured in position by concrete, metal, or other approved chairs, spacers, or ties.
- d. Splices in Reinforcement. No splices or reinforcement shall be made except as shown on the plans or as authorized by the Resident Engineer. All welding shall conform to the American Welding Society's recommended practices for welding reinforcing steel, metal inserts and connections in reinforced concrete construction (AWS D12.1).

3A.3e

- e. Concrete Protection for Reinforcement. The reinforcement shall be protected by the thickness of concrete shown on the drawings. Where not shown, the thickness of concrete over the reinforcement shall be as follows:
- (1) Where concrete is deposited against the ground without the use of forms, not less than 3 inches.
 - (2) Where concrete is exposed to the weather or to the ground but placed in forms, not less than 2 inches for bars larger than number 5, and 1 1/2 inches for number 5 bars or smaller.

DIVISION 5 - METALS
SECTION 5A
MISCELLANEOUS METALS

5A.1 DESCRIPTION OF WORK. Extent of metal work is indicated on the drawings and by the provisions of this section.

5A.2 MATERIALS.

- a. Structural Steel Shapes and Plates. ASTM A 36 steel.
- b. Steel Pipe. ASTM A53, Type E or S, Grade B steel or ASTM 501. Weight schedules shall be as specified in the special specifications or on the drawings.
- c. Anchor Bolts. ASTM A 307 without heads.
- d. Unfinished Threaded Fasteners. Where not otherwise indicated, ASTM A 307, Grade A, regular low-carbon steel bolts and nuts of hexagonal design, hot-dipped galvanized.
- e. Finished Threaded Fasteners. Stainless steel cap screws and heavy semi-finished nuts of hexagonal design for exterior connections, unless otherwise indicated.

5A.3 FABRICATION.

- a. General.
 - (1) After performing all fabrication and welding operations, remove all sharp edges and burrs that could cause injury. Properly finish surfaces of exposed items so as to be free of visible defects.
 - (2) Cut, drill, or punch holes perpendicular to metal surfaces. Do not flame cut holes.
- b. Welding. Comply with AWS Code for procedures, appearance, and quality of welds. Weld all work to produce assemblies free of warpage.
- c. Galvanizing.
 - (1) All steel members, plates, and assemblies shall be hot-dipped galvanized in accordance with ASTM A 123 and A 385, unless otherwise specified.
 - (2) Prepare all structural steel items for galvanizing by solvent cleaning, hand and power tool cleaning, and/or sandblasting as required for permanent adhesion of galvanizing.

5A.4 INSTALLATION.

- a. Install all work plumb, level, and square in accordance with the drawings.
- b. Apply high zinc-dust-content paint for repair of galvanized surfaces damaged by welding. Paint shall conform to M.I. Specification MIL-P-21035.

DIVISION 6 - CARPENTRY
SECTION 6A
ROUGH CARPENTRY

6A.1 DESCRIPTION OF WORK. The extent of exterior carpentry work is indicated on the drawings and by the provisions of this section. Refer to Section 13E for MALSR and ILS shelter carpentry.

6A.2 MATERIALS.

a. Service Pole.

- (1) Electrical service pole, if required, shall be Western Red Cedar, Douglas Fir, or Southern Pine complying with American Standard Specifications and Dimensions for Wood Poles, ASA 05.1, American Standards Association.
- (2) Poles shall be ASA 05.1 class 6 or better as dictated by height requirements.
- (3) Poles shall be pressure preservative treated with pentachlorophenol or creosote in accordance with American Wood Preservers Association (AWPA) Standard C4.

b. Lumber. Lumber shall be stress-rated and marked #2 structural grade, any species. Sizes indicated are nominal. All lumber shall be dressed S4S. All lumber shall be seasoned and have 19 percent moisture content. Hand select all lumber pieces for straightness and freedom from defects.

c. Plywood. Plywood shall be all-veneer construction of sizes indicated on the drawings, and complying with American Plywood Association (APA) grade designation: APA BC, Exterior, or better.

d. Lumber and Plywood Preservative Treatment.

- (1) All exterior lumber and plywood shall be preservative treated and shall comply with applicable requirements of the American Wood Preservers Association (AWPA) Standards C2 (lumber), and C9 (plywood), and with American Wood Preservers Bureau (AWPB) Standards below. Mark each treated item with the AWPB quality mark requirements.
- (2) Pressure treat above-grade and below-grade items with water-borne preservatives complying with AWPB LP-2 and AWPB LP-22, respectively.
- (3) Treat all cut surfaces with heavy brush coat of same chemicals used for treatment and complying with AWPA M4.

6A.2e

- e. Fasteners. Provide type, size, and finish of fasteners indicated on the drawings. All exterior fasteners shall be galvanized or stainless steel. If not otherwise specified, exterior lumber joints shall be secured with carriage bolts, flat washers and nuts, minimum two each per joint.

6A.3 CONSTRUCTION.

- a. Discard units of material with defects that could impair quality of work. Set carpentry work to required lines and levels with members plumb, level, and square. Accurately cut and fit all work.
- b. Secure all carpentry work by anchoring or fastening as required by recognized standards. Make tight connections between members. Install all fasteners without splitting wood. Pre-drill as required.
- c. Coat all exterior exposed cut edges and ends of lumber and plywood pieces with wood preservatives as required above.

DIVISION 9 - FINISHES
SECTION 9A
PAINTING

9A.1 DESCRIPTION OF WORK. Extent of work is indicated on the drawings, in the special specifications and by the provisions of this section. Refer to Section 13E for MALSR and ILS shelter painting.

9A.2 GENERAL REQUIREMENTS.

- a. Unless otherwise specified all surfaces to be painted shall receive one coat of primer and two finish coats of paint. Primer shall be compatible with the surface being painted as recommended by the paint manufacturer.
- b. At completion of painting or work of other trades, painted surfaces shall be touched-up and restored where damaged or defaced, to the satisfaction of the Resident Engineer.
- c. A completely finished job is required, regardless of whether every individual item is specified or not. Work requiring paint, which is not specifically mentioned, shall be finished in the same manner specified for other similar work.
- d. Work shall be accomplished by skilled tradesmen, and resulting work shall be uniform in appearance.

9A.3 APPLICABLE FEDERAL SPECIFICATIONS.

TT-E-489	"Enamel, Alkyd, Gloss (for Exterior and Interior Surfaces)"
TT-P-641	"Primer, Paint; Zinc Dust - Zinc Oxide (for Galvanized Surfaces)"
TT-P-645	"Primer, Paint; Zinc-Chromate, Alkyd Type"

9A.4 MATERIALS.

- a. All painting materials shall be the first quality products of a name brand paint company, which meet or exceed the requirements of the applicable federal specifications.
- b. Deliver all painting and finishing materials in original containers with seals unbroken and labels intact. No materials other than those specified or approved shall be stored on site.
- c. Basic painting materials such as linseed oil, shellac, turpentine, thinner, driers, etc., shall be of the highest quality and have identifying labels on containers.

9A.5 PREPARATION OF METAL SURFACES.

- a. Unpainted or shop painted ferrous metal shall first be washed free of grease, dirt, and oil with mineral spirits, and primed or spot primed if the metal is exposed. Prime with rust prohibitive primer after removing any existing rust.
- b. Previously painted existing ferrous metal shall be cleansed of grease, dirt, oil, and all other foreign substances. Existing paint which shows signs of deterioration, loosening, or chalking shall be removed. Further surface preparation shall be made as recommended by the paint manufacturer for the particular surface and type of paint being used.
- c. Exposed galvanized surfaces shall be solvent cleaned as necessary to remove all oil, grease, and other foreign substances. Nonferrous metal surfaces to be painted shall be treated with vinyl type wash coat. The vinyl type wash coat shall have a dry film thickness of 3 to 5 mils. The wash coat shall be permitted to dry for at least 30 minutes or as recommended by the manufacturer.

9A.6 APPLICATION.

- a. Do not apply exterior paint in damp, rainy weather, or until the surface has dried thoroughly from the effects of such weather.
- b. The temperature of the surface to be painted and the surrounding air temperature shall be maintained between 45°F and 95° during the application and drying period.
- c. The surface to be painted shall be clean, dry, smooth, and adequately protected from dampness. Each coat of paint shall be applied smoothly, worked out evenly, and allowed to dry completely before the subsequent coat is applied.
- d. Finished work shall be uniform and of the approved color. It shall be completely covered and shall be smooth and free from runs and sags. Make edges of paint adjoining other materials or colors sharp and clean without overlapping. Where high gloss enamel is used, lightly sand undercoat to obtain a smooth finish coat.
- e. All painting shall be completed according to the manufacturer's printed instructions.

9A.7 PAINT SYSTEM SCHEDULE.

- a. Ferrous Metals (Unpainted).
 - (1) Primer - Federal Specification TT-P-645
 - (2) Intermediate and Finish Coats - Exterior Oil Paint

9A.7b

b. Galvanized Metal.

- (1) Primer - Federal Specification TT-P-641
- (2) Intermediate and Finish Coats - Exterior Oil Paint

c. Aluminum.

- (1) Pretreatment - Vinyl Wash Coat
- (2) Primer - Federal Specification TT-P-645
- (3) Intermediate and Finish Coats - Federal Specifications TT-E-489.

DIVISION 13 - SPECIAL CONSTRUCTION
SECTION 13A
APPROACH LIGHT SYSTEMS

13A.1 DESCRIPTION OF WORK. This section is applicable for construction required for a Medium Intensity Approach Lighting System with Runway Alignment Indicator Lights (MALSR) and other approach lighting systems utilizing similar construction.

13A.2 INSTALLATION OF MALSR LIGHTS.

a. Screw Anchor Foundations. Comply with Section 13D and project drawings if screw anchor foundations are required on the drawings.

b. Installation Tolerances. Installation tolerances for the various types of light bars and flasher units shall be as follows:

- | | |
|--|------------|
| (1) Longitudinal (along the runway centerline) | + 6 inches |
| deviation from design station. | |
| (2) Lateral (perpendicular to the runway centerline). | + 3 inches |
| (3) Horizontal distance between individual frangible lights. | + 1 inch |
| (4) Mounting height. | |
| (a) Up to 6 feet. | + 1 inch |
| (b) 6 to 40 feet. | + 2 inches |
| (c) Over 40 feet. | + 3 inches |
| (5) All lights in a frangible bar shall be installed within + 1 inch of a line perpendicular to the runway centerline. | |

c. Assembly of PAR-56 Lights. If installation of PAR-56 lights is included in the contract, the contractor shall assemble the PAR-56 lampholders, lamps, and, if included, filter-holding clips, colored glass filters, and (for ALSF-2 facilities) shorting devices, into complete units, from unassembled condition. Use the spring-loaded lamp-retaining hardware supplied with the lampholders.

d. Frangible EMT Mountings.

- (1) Frangible Coupling Installation. Each frangible coupling has a hexagonal throat with a break-off groove in the middle, designed to break at low impact, thereby minimizing damage to colliding aircraft. When installing the frangible coupling, take care to use a

wrench which will grip only the lower portion of the hexagonal throat of the coupling, i.e., that portion immediately below the break-off groove. If the wrench grips the upper portion of the hexagonal throat, the coupling may break when torque is applied. See Paragraph 16A.20 for thread remediation. Whether thread remediation is performed or not, the contractor shall apply anti-seize compound to the threads of the frangible coupling, and to the internal threads of the receiving coupling or hole, to facilitate removal. The compound shall be an anti-seize assembly lubricant formulated to provide protection for stainless steel and dissimilar metal threaded fasteners against galling, seizure, and heat-freeze. Do not use plumber's pipe-joint compound. The frangible coupling shall be screwed down tightly into the conduit coupling or light base cover plate threaded hole, to prevent the EMT mounting from turning.

- (2) Cable Connectors. Where cable connectors are required within the frangible couplings, the connectors shall have the capability of separating easily upon breakage of the frangible couplings. Therefore, apply silicone grease of high dielectric strength to the mating surfaces of the plug and receptacle connectors. Do not allow the silicone grease to make contact with the plug and receptacle terminals, and do not place electrical tape over the connector joints. A cable clamp or cable connector clamp shall firmly grip the receptacle connector of the lower cable assembly (never the plug connector of the upper cable assembly). The connectors shall be vertically positioned such that the joint between the two connectors is as close as feasible to the breakoff groove. If the receptacle cable connector is the 1"-diameter style (e.g., 90R-B6), the connector shall be gripped by an aluminum split-ring cable clamp. The Multi Electric Part No. 961-X cable clamp is among the clamps which meet this specification. If the receptacle cable connector of the style having a 1.75-inch-diameter donut for use in a light base (such as on the secondary lead of isolation transformers), the connector shall be gripped by the cable connector clamp which comes with the base plate.
- (3) Upper Cable Assembly. Sufficient slack shall be left in the upper cable assembly at the point of entering the lampholder to permit:
 - (a) Removal of the lampholder.
 - (b) Disconnection of the cable connectors in the frangible coupling without disturbing connections to the lampholder.

13A.2e

- e. Plumbness Tolerance for EMT Frangible Light Masts. EMT frangible light masts shall be installed to a plumbness tolerance of 1/16-inch per foot of mast height. This requirement is in addition to all other placement tolerances. If the mast foundation is concrete, the plumbness tolerance shall be met by proper placement of the concrete-embedded section of conduit, not by bending the mast. To insure plumbness, temporary rigid conduit masts shall be threaded into the conduit couplings, and clamped in place in a rigid brace during concrete placement, finishing, and setting. If the masts are to rise from a steel channel attached to a screw anchor foundation, the plumbness tolerance shall be met by proper attachment of the conduit couplings to the channel, not by bending the masts. In this case, temporary rigid conduit masts shall be threaded into the conduit couplings, and clamped in place in a rigid brace during the welding of the couplings to the channel.
- f. Fiberglass LIR Approach Lighting Towers. LIR means Low Impact Resistance. An LIR tower is a tower designed to disintegrate when struck by an aircraft, offering low impact resistance to the aircraft, thus minimizing aircraft damage. The fiberglass LIR towers, if required by the drawings, shall be assembled from knocked-down (unassembled) condition according to the manufacturer's assembly instructions. Install the towers on foundations constructed in accordance with the drawings. On drawings, for brevity, fiberglass LIR towers are sometimes also called masts and poles.
- g. Aiming and Alignment of Lights. Each light shall be adjusted so that its optical axis is parallel to the runway centerline, directed outward from the runway threshold, and aimed upward to the required vertical angle. An aiming device is furnished for vertical aiming of the PAR-56 and the PAR-38 lampholders and flashing light units.

13A.3 MALSR BRIGHTNESS. The contractor shall adjust the MALSR to operate as follows:

<u>Step</u>	<u>% Relative Intensity</u>	
	<u>MALS</u>	<u>RAIL</u>
High Intensity	100	100
Medium Intensity	20	8
Low Intensity	4	1

13A.4 OPERATIONAL TESTS. The contractor shall demonstrate, by operational tests, that the entire system will operate satisfactorily. If the contract requires the establishment of remote control, satisfactory system operation shall be demonstrated on remote and local control. If the contract does not require the establishment of remote control, satisfactory system operation shall be demonstrated on local control

13A.4

only. The test shall demonstrate that the system meets all requirements of this specification and of the manufacturer's instruction manual.

13A.5 MALS LAMPS. If MALS lamps are not shown on the Government-Furnished Property List, the contractor shall furnish ninety (90) PAR-38, 120-watt spot lamps. The photometric performance of these lamps shall equal or exceed the vertical and horizontal brightness beam spread candela values shown on Figure L at the end of this section. The Figure L beam spread curves were approximately reproduced from the July 1983 FAA Technical Center data report on photometric tests of MALS PAR-38 spotlights. The lamps must also be physically shaped to fit the PAR-38 lamp aiming device supplied as part of the MALSR equipment from the MALSR manufacturer. The General Electric PAR-38 120V, 120W, Wattmiser spot lamp (GE Designation 150 PAR/SP/120/WM) is one of the products which meet these specifications. If the contractor intends to furnish a substitute lamp, the contractor shall submit to the Contracting Officer, complete manufacturer's information, including vertical and horizontal brightness beam spread candela values, and a sample lamp, to demonstrate that the lamp will fit the MALSR manufacturer's PAR-38 lamp aiming device. See Paragraph 1A.4 above. The contractor shall install the required number of these lamps on the MALS structures. The remaining lamps shall be delivered to the Resident Engineer as spares.

13A.6 MALSR CABLE SPLICES.

- a. Restrictions. The only underground MALSR cable splices which will be permitted under this contract will be the splices shown on the drawings. The contractor shall inventory the reels of Government-furnished cable and contractor-furnished cable, to verify that sufficient continuous lengths are available to preclude any other splices. If the contractor discovers that insufficient continuous lengths are furnished, he shall report this condition to the Resident Engineer immediately.
- b. Mold and Compound. Every 600-volt power cable splice shall be made with a flexible film plastic mold with a built-in spacer web to provide cable and connector centering, and proper coverage by the insulating and sealing compound. The applied mold shall be filled with a flexible polyurethane electrical insulating and sealing compound capable of continuous operation at 90°C, with an emergency overload temperature rating of 130°C. The splices shall be rated for direct burial applications. The splicing kits shall be sized properly to the application. Splicing kits of the 3M Scotchcast 85 series are among products which meet these specifications. If kits of this series are selected, splices at the threshold bar, at EMT light bars, and at

13A.6b

5-tower bars, shall be made with 85-16 kits, unless specified otherwise. Splices at the MALS T-bar towers shall be made with kits no smaller than 85-12, unless specified otherwise. Substitute splicing kits require submittals per Paragraph 1A.4 above.

- c. Connectors. Connectors used in the splices shall be compact compression tap connectors properly sized to the application. The connectors shall be copper, except aluminum connectors are permitted if they are designed for use with copper conductors. The contractor shall furnish and use the proper crimping tools and dies for the connectors, and shall execute the number of crimps required by the manufacturer. Mechanical (bolted) tap connectors shall not be used in splices below grade. The following connectors, primarily for underground splices at MALS bars, are approved, as they are among the products which meet these specifications (substitutes require submittals per Paragraph 1A.4 above):

- (1) The following Burndy Crimpit Type YC-C compression connectors:

<u>Cat. No.</u>	<u>Run</u>	<u>Tap</u>
YC10C10	#10 AWG	#10 AWG
YC8C8	#8 AWG	#10 AWG
YC26C2	#2/0 AWG	#2 AWG
YPC26R8U	#2/0 AWG	#10 AWG

- (2) For #2, #4, or #6 run cable to #10 tap cable, Burndy street lighting tap, Catalog Number YPC2A8U.

13A.7 MALS POWER DISTRIBUTION PANEL CIRCUIT DIRECTORY. The contractor shall mark the MALS power distribution panel circuit directory, identifying each branch circuit breaker by the MALS bar station(s), each breaker serves. Spare breakers shall be so identified.

DIVISION 13 - SPECIAL CONSTRUCTION
SECTION 13B
INSTRUMENT LANDING SYSTEM

- 13B.1 DESCRIPTION OF WORK. This section applies to special construction required for an Instrument Landing System (ILS).
- 13B.2 SCREW ANCHOR FOUNDATIONS. Comply with Section 13D and project drawings if screw anchor foundations are required on the drawings.
- 13B.3 CABLE SPLICES. No splices will be permitted in radio frequency cables (cables with an RG designation, e.g. RG333/U).
- 13B.4 OBSTRUCTION LIGHTS. The obstruction lights on the glide slope antenna mast shall be installed and lighted continuously when the tower is 20 feet high or higher.

DIVISION 13 - SPECIAL CONSTRUCTION
SECTION 13C
VASI, REIL, PAPI, AND RVR SYSTEMS

13C.1 DESCRIPTION OF WORK. This section applies to special construction required for a Visual Approach Slope Indicator (VASI), Runway End Identifier Lights (REIL), Precision Approach Path Indicator (PAPI), and New Generation Runway Visual Range (RVR).

13C.2 FRANGIBLE SUPPORTS FOR VASI, REIL, PAPI, AND RVR EQUIPMENT.

- a. Description. Frangible couplings will be used to support VASI, REIL, PAPI, and RVR equipment installed near runways. Each frangible coupling has a hexagonal throat with a break-off groove in the middle, designed to break at low impact, thereby minimizing damage to colliding aircraft.
- b. Coupling Installation. When installing the frangible coupling, take care to use a wrench which will grip only the lower portion of the hexagonal throat of the coupling, i.e., that portion immediately below the break-off groove. If the wrench grips the upper portion of the hexagonal throat, the coupling may break when torque is applied. See Paragraph 16A.20 for thread remediation. Whether thread remediation is performed or not, apply anti-seize compound to the threads of the frangible coupling, to facilitate removal. The compound shall be an anti-seize assembly lubricant formulated to provide protection for stainless steel and dissimilar metal threaded fasteners against galling, seizure, and heat-freeze. Do not use plumber's pipe-joint compound. The frangible coupling shall be screwed down tightly into the conduit coupling.
- c. Cable Connectors. Where cable connectors are required within the frangible couplings, the connectors shall have the capability of separating easily upon breakage of the frangible couplings. Therefore, apply silicone grease of high dielectric strength to the mating surfaces of the connector plug and receptacle housings in the frangible couplings. Do not allow the silicone grease to make contact with the plug and receptacle terminals, and do not place electrical tape over the connector joints. A cable clamp shall firmly grip the receptacle connector of the lower cable assembly (never the plug connector of the upper cable assembly). The connectors shall be vertically positioned such that the joint between the two connectors is as close as feasible to the breakoff groove.

13C.3 EQUIPMENT ELEVATIONS.

- a. Elevations of Record. After the contractor has installed the VASI, REIL, PAPI, or RVR lighting unit foundations (concrete or screw anchor), he shall survey and record all such independent foundation top elevations to the nearest

13C.3a

0.01 foot and deliver this information to the Resident Engineer for as-built drawing record. Elevations should be clearly referenced to locations where measured, such as a specific corner of a screw anchor or anchor plate. It is emphasized that all foundations of every lighting unit shall be measured such as the four legs of an individual VASI box.

- b. Elevation Verification. Runway elevations indicated on the drawings were established on the date indicated. Prior to using these elevations for construction survey proposes, the contractor shall verify, through the Resident Engineer, that such runways have not been resurfaced after the date of the engineering survey. If resurfacing has occurred, new benchmarks will be established by the Resident Engineer. The VASI unit light slot elevations shall not be altered from those indicated on the drawings.

13C.4 ALIGNMENT AND AIMING ANGLE TOLERANCES.

- a. Aiming Angles. Refer to site drawings for locations and aiming angles for individual VASI, REIL, PAPI, or RVR lighting units.
- b. VASI and PAPI Lamp Housing Assembly (LHA) Unit Tolerances.
 - (1) Longitudinal Alignment Tolerances. Front face of each LHA unit shall be located within ± 6 inches of single line perpendicular to the runway centerline.
 - (2) Azimuthal Alignment Tolerance. Longitudinal axis of each LHA unit shall be parallel to the runway centerline within $\pm 1/2$ degree.
 - (3) Mounting Height Tolerance. Light beam centerline of each LHA unit (within a bar for VASI) shall be located on a single horizontal plane within \pm one inch.
 - (4) Aiming Angle Tolerance. Aiming angle of each LHA unit shall be within ± 2 minutes of angle specified.

13C.5 SYSTEM CONTROL. Unless otherwise indicated, VASI, REIL, or PAPI system construction shall include a method of on/off control shown on the drawings or specified herein. REIL control will also include provision for varying the lighting intensity.

13C.6 OPERATIONAL TESTS. The contractor shall demonstrate that the VASI, REIL, or PAPI system will operate satisfactorily by a series of operational test cycles and a continuous test run of 24 hours minimum. The tests shall clearly indicate that the system meets all the requirements of the drawings, specifications, and the manufacturer's instruction manuals.

DIVISION 13 - SPECIAL CONSTRUCTION
SECTION 13D
SCREW ANCHOR FOUNDATIONS

- 13D.1 DESCRIPTION OF WORK. This section is applicable if screw anchor foundations are required on the drawings.
- 13D.2 SCREW ANCHOR FOUNDATION DESIGN AND USAGE. On drawings, screw anchor foundations are also called screw-in foundations and screw-in-anchor foundations. The two most frequently used screw anchor foundations, and the PAPI plate, are shown on Figures 1, 2, and 3 at the end of this section. The Figure 1 foundation is commonly used for ILS, RVR, MALSR, and PAPI facilities. The Figure 2 foundation is commonly used for VASI and REIL facilities. A. B. Chance foundations, Cat. Nos. T112-0262 and T112-0676, and PAPI plate T112-0337, are among the products that meet the requirements of Figures 1, 2, and 3, respectively, and the specifications below. These items are also known by Cat. Nos. CT112-0262, CT112-0676, and CT112-0337. The Chance Figure 1 foundation is known as an "Instant" foundation (formerly known as a streetlight foundation).
- 13D.3 PLATES. The following specifications apply to the square top plate (base plate) which is an integral part of the Figure 1 screw anchor foundation, and to the Figure 3 PAPI plate. The flat, smooth, plate top surface shall not have any curvature or other deformity induced by the manufacturing process. The plate shall be flame cut, deburred, and machined smooth both on the external edges and on the inner holes and slots. During fabrication of the Figure 1 foundation, the base plate edge shall be permanently and plainly marked in a highly visible manner, indicating the shaft cableway slot location, manufacturer, and Julian date. All tapped holes are to be center tapped within 1 degree of perpendicular to the plate. The threads shall be fully cleaned after hot dip galvanizing, such that a bolt may be hand run in the threads.
- 13D.4 SHAFT. Foundation shafts shall be machine flame cut to the length specified on the figure. The shaft shall be 90° square-cut on the top end, and to the true helical shape on the bottom end. The cableway slot (Figure 1 only) shall be machine smoothcut on one side of the shaft. The sides of the cableway openings shall be within 1/2 degree of parallel, as measured along their full length. The round shaft material shall be new, unused, and mill traceable.
- 13D.5 ASSEMBLY. Weld the component parts as Figures 1 and 2 specify. The completed assemblies (Figures 1, 2, and 3) must be hot dip galvanized after fabrication. Each Figure 1 foundation shall be supplied with four sets of carriage bolts, hex nuts, and lock washers. When bolts, nuts, and lock washers are shipped assembled, the nuts shall be tightened securely to prevent loss in shipment. Otherwise, the hardware shall be supplied in a burlap bag securely taped to the foundation.

13D.6 QUALITY ASSURANCE. No screw anchor foundations will be accepted from a manufacturer, unless the manufacturer has in place and in operation, a quality assurance department as a separate and distinct element of the manufacturer's organization. The quality assurance department must:

- a. Employ quality assurance engineers who execute quality assurance by industry-accepted methods such as Statistical Process Control (SPC).
- b. Maintain, and operate under, a quality assurance manual defining quality control functions and operations such as:
 - (1) Controlling the quality of incoming raw materials.
 - (2) In-process inspection, assembly inspection, and final inspection and tests, including specific actions to be taken when defects are found.
 - (3) Integration of quality assurance practices into the manufacturing process at the level of individual production operators.
 - (4) Welder certification. The qualification of personnel must be accomplished in accordance with the American Welding Society, Structural Welding Code (D1.1-83).
 - (5) Tool and gauge control, including calibration test schedules.
 - (6) Record keeping for all of the above quality assurance actions.

13D.7 INSTALLATION EQUIPMENT. If screw anchor foundations are shown on the drawings, the contractor shall furnish the installation equipment. The digger derrick or other driving equipment shall have sufficient clearance between the driving head and the ground to accommodate the screw anchor foundations specified. Pre-drilling (see Paragraph 13D.8c, below) or any other excavation at the anchor installation site for the purpose of gaining clearance under the driving head to accommodate the length of the anchor foundations, is expressly prohibited.

- a. Figure 1 Foundation. The Figure 1 foundation requires the following items of installation equipment:
 - (1) Kelly bar adapter selected to fit directly to the kelly bar (rotating shaft) of the driving equipment.
 - (2) A tool to transmit the driving torque from the kelly bar adapter to the Figure 1 foundation. This driving tool must fit the kelly bar adapter and the Figure 1 foundation. Universal Driving Tools A. B. Chance Catalog No. C303-0139 and C303-0684, are two of the products that meet this requirement.

13D.7a(2)

These tools are used to drive Figure 1 foundations. The moderate-strength (C303-0139) tool connects to the kelly bar adapter with six 1/2"-dia bolts. The high-strength (C303-0684) connects to the kelly bar adapter with up to twelve 5/8"-dia bolts. Both tools have various bolt holes for attachment to the anchor foundation.

A range of moderate-strength kelly bar adapters for various kelly bar dimensions is presented in Figure 4, with an illustration of Universal Driving Tool C303-0139. A range of high-strength kelly bar adapters for various kelly bar dimensions is presented in Figure 5, with an illustration of Universal Driving Tool C303-0684. The A. B. Chance items listed and illustrated are among the products which meet requirements. The contractor may substitute other drive tooling without submittals if the substitute tooling is dimensionally and dynamically compatible with the kelly bar and foundation.

- b. Figure 2 Foundation. The Figure 2 foundation requires the following items of installation equipment:
- (1) Kelly bar adapter selected to fit directly to the shaft of the driving equipment.
 - (2) A tool to transmit the driving torque from the kelly bar adapter to the Figure 2 foundation. This driving tool must fit the kelly bar adapter and the Figure 2 foundation. The Wrench Driving Tool, Chance Cat. No. 639000, is one of the products which meet this requirement. This tool is used to drive Figure 2 foundations. It has a square 2-inch socket and two set screws which serve to connect the tool to the screw anchor foundation.

A range of kelly bar adapters for various kelly bar dimensions is presented on Figure 6, with an illustration of the Wrench Driving Tool. The A. B. Chance items listed and illustrated are among the products which meet requirements. The contractor may substitute other drive tooling without submittals if the substitute tooling is dimensionally and dynamically compatible with the kelly bar and foundation.

13D.8 SCREW ANCHOR FOUNDATION INSTALLATION REQUIREMENTS.

- a. Plumbness. The foundations shall be installed plumb, within a tolerance of 1/8" horizontal per foot vertical.
- b. Foundation Top Elevation and Cableway Orientation. The foundation shall not be backed out to meet a specific foundation top elevation. Therefore, the top elevation must be checked as the foundation is driven. Foundations shall be turned down an additional fraction of a revolution in order to properly align the bolt holes. If a specific orientation of the cableway slot in the shaft is required (e.g., facing the RVR power and control stand), the contractor shall so orient the shaft.

13D.8c

c. Pre-drilling.

- (1) Pre-drilling is defined as augering a hole centered on the design location of a foundation. Pre-drilling is sometimes necessary in very stiff soils, to permit driving the foundation to design depth without exceeding a torque which would damage the foundation.
- (2) Pre-drilling, if authorized by the Resident Engineer, shall be accomplished using an auger not larger in diameter than the foundation shaft diameter (not helix diameter).
- (3) The need for, and depth of, pre-drilling shall be determined solely by the Resident Engineer, with information from the contractor. The contractor shall do no pre-drilling until the Resident Engineer authorizes him to do so. The contractor shall not pre-drill to a depth greater than the depth authorized by the Resident Engineer.

13D.9 Procurement. Unless specified otherwise, screw anchor foundations shall be furnished by the contractor. If the contractor intends to furnish foundations other than the A. B. Chance foundations accepted in Paragraph 13D.2, the contractor shall submit complete manufacturer's information, including the quality assurance manual, and shop drawings, to the Contracting Officer. The contractor shall not procure the substitute screw anchor foundations before receiving the Contracting Officer's approval. See Paragraph 1A.4 above.

DIVISION 13 - SPECIAL CONSTRUCTION
SECTION 13E
MALSR AND ILS EQUIPMENT SHELTERS

13E.1 DESCRIPTION OF WORK. This section is applicable if equipment shelter construction is required for a MALSR or ILS. Extent of work is indicated on the drawings. All wood-frame shelters shall be constructed on their foundations, unless specified otherwise.

13E.2 SHELTER CARPENTRY.

a. Lumber and Plywood Materials.

(1) General Requirements.

- (a) Factory mark each piece of lumber and plywood identifying grading agency, grade, and species.
- (b) All lumber sizes are nominal, dressed S4S and seasoned to 19 percent moisture content.

(2) Dimension Lumber.

- (a) Studs. "Stud" grade, any species.
- (b) Joists, Rafters and Plates. "Structural Joists and Planks" Number 2 grade or better, any species. Plates in contact with concrete shall be pressure treated.

(3) Plywood Sheathing. All veneer plywood complying with following:

- (a) Exterior sheathing. APA Structural 1 Rated Sheathing, Exterior, Exposure 1, or APA CC Plugged Exterior of sizes indicated.
- (b) Interior Sheathing. APA AC Exterior.

b. Installation.

- (1) Securely attach carpentry work by anchoring and fastening as shown or as required by recognized standards. Set work to required lines and levels with members plumb and accurately cut and fitted.
- (2) Use common nails except as indicated. Select fastener sizes that will not conflict with other work.

13E.3 SHELTER DOOR AND FRAME.

- a. Quality Assurance. Provide doors and frames complying with Steel Door Institute "Recommended Specifications: Standard Steel Doors and Frames" (SDI-100) and as herein specified.
- b. Fabrication.
 - (1) General. Fabricate steel door and frame units to be rigid, neat in appearance, and free from defects, warpage, and buckle. Wherever possible, fit and assemble units in the manufacturer's plant.
 - (2) Door Type/Grade. Doors shall be SDI-100, Grade III, extra heavy duty, Model 1, full flush, minimum 16 gage faces, 1 3/4 inch thick.
 - (3) Construction.
 - (a) Fabricate exposed faces of door and panels from cold-rolled steel only. Fabricate concealed stiffeners, reinforcement, and edge channels from either cold or hot rolled steel at fabricator's option. All door and frame materials shall be galvanized.
 - (b) Close top and bottom edges of exterior doors flush as an integral part of construction or by the addition of 16-gage channels.
 - (4) Thermal Insulation. Door and frame shall be thermal-rated (insulated) assemblies tested in accordance with ASTM C 236. Provide thermal insulation with maximum U factor of 0.1 BTU/(hr ft² °F).
 - (5) Finish Hardware Preparation.
 - (a) Prepare doors and frames to receive mortised and concealed finish hardware in accordance with Subsection 13E.4, and templates provided by hardware supplier. Comply with applicable requirements of ANSI A115 series specifications for door and frame preparation for hardware.
 - (b) Reinforce doors and frames to receive surface-applied hardware. Drilling and tapping for surface-applied finish hardware may be done at project site.
 - (c) Locate finish hardware in accordance with "Recommended Locations for Builder's Hardware", published by the Door and Hardware Institute.

13E.3b(6)

- (6) Door Frames. Fabricate door frames of style shown on the drawings. Conceal fastenings and fabricate frames from minimum 16-gage galvanized cold rolled furniture-quality steel. Fabricate frames with mitered and welded corners.
- (7) Shop Painting. Apply shop coat of primer paint to provide a uniformly finished surface ready to receive finish coats.

c. Installation.

(1) Placing Frame.

- (a) Comply with provisions of SDI-105 "Recommended Erection Instructions for Steel Frames".
- (b) Install at least 3 wall anchors per jamb at hinge and strike levels. Anchor to wood stud framing using fasteners and devices for rigid attachment.

(2) Doors. Fit hollow metal doors accurately in frames, within clearances specified in SDI-100.

(3) Adjust and Clean.

- (a) Immediately after erection, sand smooth any corroded or damaged areas of prime coat and touch-up paint with compatible primer.
- (b) Apply finish paint coats per Division 9.
- (c) Check and readjust operating finish hardware items, leaving steel doors and frames undamaged and in complete and proper operating condition.

13E.4 DOOR HARDWARE.

a. General Requirements.

- (1) Templates. Furnish hardware templates to fabricator of doors and frames to be factory-prepared for installation of hardware.
- (2) Finish. BHMA #612 (Federal Specification US 10) satin bronze plated for hinges and lock set.
- (3) Fasteners. Provide Phillips flat-head machine screws, matching finish and of proper design size for hardware item furnished.

b. Materials.

- (1) Hinges. Provide 1 1/2 pair 4 1/2 x 4 1/2 hinges, full mortise type, heavyweight, ball bearing, five knuckle, square corner, swaged, steel with steel pin, non-removable and non-rising pin, flat button and matching plug tips. Stanley #FBB-168 is one of the products meeting these specifications.
- (2) Lockset. Provide mortise lockset, Best Lock Corporation Catalog Number 35H-7-F-3-J-626-RHRB having a 7-pin cylinder and furnished without core. The FAA Resident Engineer will supply the construction core which the Resident Engineer receives from FAA sector personnel. The contractor shall install the construction core. No substitution for the above lockset will be permitted.
- (3) Doorholder. Provide a door holder, overhead surface type, exterior door use, with safety release, combination door stop, shock-absorbing cushion, and holder complying with FS 1161 and BHMA C012511. Glynn-Johnson #GJ90M is one of the products meeting these specifications.
- (4) Threshold. Provide an aluminum threshold not less than 3 1/2 inches wide, and of such height that weatherstripping insert will contact inner face of door. Threshold shall include rabbeted design with replaceable neoprene insert in step. Zero #563 Rabbeted Saddle is one of the products that meets these specifications.
- (5) Weatherstripping at Door Jambs and Head. Provide continuous weatherstripping at all edges of doors. Provide only those units where resilient seal strips are easily replaceable and readily available from the manufacturer. Construction shall include flexible neoprene bulb insert in extruded aluminum channel with snap-on cover, hidden fasteners, surface-mounted design. Zero #475 is one of the products that meet these specifications.

c. Installation.

- (1) Hardware Mounting Heights. Mount units of hardware at heights indicated in "Recommended Locations for Building Hardware for Standard Steel Doors and Frames" by the Door and Hardware Institute.
- (2) Procedures.
 - (a) Install each item per manufacturer's instructions.

13E.4c(2) (b)

- (b) Set units level, plumb and true to line and location. Adjust and reinforce the attachment substrate as necessary for proper installation and operation.
- (c) Drill and countersink units which are not factory prepared for anchor fasteners. Space fasteners in accordance with industry standards.
- (d) Set thresholds in full bed of butyl-rubber or polyisobutylene mastic sealant.

13E.5 INSULATION.

- a. Material. Wall and ceiling installation shall be fiberglass batt insulation faced with coated Kraft paper. Insulation batts shall have staple flanges. The batts shall be nominally 6 inches thick, with R-19 insulation value. Batt width shall be compatible with stud spacing.
- b. Installation. Install insulation batts between all studs and joists such that batts will retain full thickness. Stuff loose fiberglass insulation into cracks impossible to fill with batts. Compress loose insulation no tighter than 50 percent of normal volume when needed to hold it in place.

13E.6 RESILIENT FLOORING.

- a. General.
 - (1) Manufacturer. Provide resilient flooring and accessories as produced by a single manufacturer including recommended primers, adhesives, and leveling compounds.
 - (2) Temperatures. Maintain 65° minimum temperature in space to receive flooring for at least 48 hours before installation, during installation, and for at least 48 hours thereafter. Store flooring materials in space where they will be installed for 48 hours prior to installation.
 - (3) Order of Work. Install resilient flooring and accessories after completion of painting and other finishing work. Do not install over concrete slab until the concrete is cured to the satisfaction of the Resident Engineer.
- b. Materials.
 - (1) Floor Tile. Material shall be vinyl composition tile complying with FS SS-T-312, Type IV, 12" x 12", 1/8-inch gage, composition 1 (asbestos free). The following products are among products that meet the specifications:

13E.6b(1)

Armstrong: Standard Excelon, Imperial Texture - #51890 Desert Tan.

Azrock: Custom Cortina - V846 Thyme.

Kentile: Architectural Criterion - #1458 Wheat.

- (2) Vinyl Wall (Cove) Base. Material shall be vinyl base complying with FS SS-W-40, Type II, with matching end stops and preformed or molded corner units. Height shall be 4 inches, thickness 0.080 inch. Style shall be standard top-set cove with toe. The following products are among products that meet these specifications:

Armstrong: #124 Pecan.

Azrock: #YCB-5 Beige.

Kentile: #KC-22 Taupe.

- (3) Adhesive (Cements). Waterproof, stabilized type as recommended by flooring manufacturer for material and substrate conditions.
- (4) Concrete Slab Primer. Non-staining type as recommended by flooring manufacture.
- (5) Leveling and Patching Compounds. Latex types as recommended by flooring manufacturer.
- (6) Floor Wax. Product recommended by floor tile manufacturer.

c. Installation.

- (1) Preparation.
- (a) Use leveling and patching compounds as recommended by flooring manufacturer for filling small cracks, holes, and depressions in slabs.
- (b) Remove coatings from slab surfaces that would prevent adhesive bond, including curing compounds if incompatible with flooring adhesive.
- (c) Broom clean or vacuum surfaces.
- (d) Apply concrete slab primer, if recommended by flooring manufacturer.

13E.6c(2)

(2) Floor Tile.

- (a) Install in strict compliance with manufacturer's printed instructions. Extend floor tile into door reveals and similar openings.
- (b) Scribe, cut, and fit floor tile to permanent fixtures, columns, walls, conduit and similar construction.
- (c) Tightly cement floor tile to slab without open cracks, voids, raising, and puckering at joints, telegraphing of adhesive spread marks or other imperfections. Hand roll at perimeter of each covered area to assure adhesion.
- (d) Lay tile from center marks established with principal walls, discounting minor offsets, so that tile at opposite edges of room area are of equal width. Adjust as necessary to avoid use of cut widths less than 1/2 tile at room perimeters.
- (e) Cut tile neatly around all obstructions. Broken, cracked, chipped or deformed tiles are not acceptable.
- (f) Lay tile in "checkerboard" fashion with grain reversed in adjacent tiles.
- (g) Adhere tile flooring to slab using full spread of adhesive applied in compliance with flooring manufacturer's directions.

(3) Wall Base. Install base in lengths as long as practical with preformed corner units or fabricated from base material with mitered or coped inside corners. Tightly bond base to substrate throughout length of each piece, with continuous contact at horizontal and vertical surfaces.

- d. Cleaning and Protection. Perform the following operations immediately upon completion of tile installation work. Sweep or vacuum floor thoroughly, but do not wash until tile adhesive has cured as recommended by manufacturer. Damp mop and remove any excess adhesive and other blemishes using cleaners recommended by manufacturer. Apply wax as recommended by manufacturer.

13E.7 PAINTING.

- a. General Requirements. Comply with all requirements of Section 9A, excepting paint system schedule, and the requirements of this subsection.

13E.7b

b. Surfaces to be Painted.

(1) Interior.

- (a) Plywood ceiling and wall surfaces.
- (b) Wood trim and all other exposed finish carpentry work.
- (c) Steel door and frame.
- (d) All exposed conduit, outlet and switch boxes, but not pre-finished large electrical wall-mounted equipment enclosures.

(2) Exterior.

- (a) Steel door and frame.
- (b) Air intake hood.
- (c) Air conditioner sleeve surfaces and supports.

(3) Ancillary Items. Major surfaces to be painted are those listed above. Paint minor items affixed or adjacent to such surfaces the same color as primary items.

(4) Exclusions. The following equipment shall not be painted:

- (a) Pre-finished safety switch, power panelboard, electrical equipment enclosures and other large similar electrical items.
- (b) Exhaust fan.
- (c) Air conditioner.
- (d) Ventilation dampers and motor operators.

c. Materials.

(1) Single Source Responsibility. Provide primers and other undercoat paint produced by same manufacturer as finish coats. Use only thinners approved by paint manufacturer, and use only within recommended limits.

(2) Colors.

- (a) Interior and exterior surfaces of door and frame shall be a medium gray color approved by the Resident Engineer.

13E.7c(2)(b)

(b) Interior wall and ceiling surfaces shall be white.

(3) Federal Specifications. Federal specification references establish minimum acceptable quality of paint materials. Provide written certification from manufacturer that materials provided meet or exceed the minimum if not so indicated on product labels.

d. Paint Schedule. In the paint schedule below, the following manufacturer codes in parentheses are used:

Benjamin Moore and Co. (Moore).

PPG Industries, Pittsburgh Paints (PPG).

Pratt and Lambert (P&L).

The Sherwin-Williams Company (S-W).

(1) Ferrous Metal. Provide two finish coats over primer. Omit primer for items delivered shop primed.

(a) Prime Coat. Red Lead Pigmented Primer (FS TT-P-86). The following products are among products which meet FS TT-P-86.

Moore: Ironclad Retardo Rust Inhibitive Paint.

PPG: UC 10424 Red Lead Primer.

P & L: P & L Red Lead Primer.

S-W: S-W Kromik Metal Primer.

(b) First and Second Finish Coats. High Gloss Alkyd Enamel (FS TT-E-489). The following products are among products that meet FS TT-E-489:

Moore: Impervo High Gloss Enamel
Exterior/Interior.

PPG: 6-252 Speedhide Quick-Dry Alkyd Enamel.

P & L: Effecto Enamel.

S-W: S-W Metalistic II Enamel.

13E.7d(2)

(2) Zinc-Coated Metal (New Unpainted Galvanized). Provide two finish coats over primer.

(a) Prime Coat. Zinc Dust - Zinc Oxide Primer (FS TT-P-641). The following products are among products that meet FS TT-P-641:

Moore: Ironclad Galvanized Metal Primer.

PPG: 6-215 Speedhide Galvanized Steel Primer.

S-W: S-W Galvanized Iron Primer.

(b) First and Second Finish Coats. High-Gloss Alkyd Enamel (FS TT-E-489), same as for ferrous metal.

(3) Interior Plywood.

(a) Lusterless (Flat) Emulsion Finish. Provide two coats.

(b) First Coat. Interior Latex Base Primer Coat (FS TT-P-650). The following products are among products that meet FS TT-P-650:

Moore: Moore's Latex Quick-Dry Prime Seal.

PPG: 6-2 PPG Quick-Drying Interior Latex Primer Sealer.

P & L: Pro-Hide Plus Latex Primer.

S-W: S-W Pro-Mar Latex Wall Primer.

(c) Second Coat. Interior Flat Latex Base Paint (FS TT-P-29). The following products are among products that meet FS TT-P-29.

Moore: Moore's Regal Wall Satin.

PPG: 6-70 Speedhide Latex Flat Wall Paint.

P & L: Pro-Hide Plus Latex Flat.

S-W: S-W Pro-Mar 400 Latex Flat Wall Paint

e. Application.

(1) Remove hardware, hardware accessories, plates, and similar in-place items not to be finish-painted, or provide surface-applied protection prior to surface preparation and painting operations. Following completion of painting, reinstall removed items.

13E.7e(2)

- (2) Finish exterior door on top, bottom and side edges, the same as exterior face. Sand lightly between each succeeding enamel coat. Omit first coat (primer) on metal surfaces which have been shop-primed and touch-up painted.

f. Clean-Up and Protection.

- (1) Upon completion of painting work, clean any paint-spattered surfaces. Remove spattered paint by proper methods of washing and scraping, using care not to scratch or otherwise damage finished surfaces.
- (2) Protect work of other trades, whether to be painted or not, against damage by painting and finishing work. Correct any damage by cleaning, repairing, or replacing, and repainting, as acceptable to the Resident Engineer.

13E.8 STEEL SIDING. Furnish and install steel siding panels and accessories in accordance with manufacturer's instructions and the following material specifications.

- a. Steel Sheet and Forming. The steel sheet of the siding panels shall be .15 maximum carbon steel. The sheet shall have a G90 galvanized finish applied by the continuous hot-dipped galvanized method per ASTM Specifications A-525-81 and A-526-80. The nominal thickness of the sheet after galvanizing shall be 0.0165-inch. The siding shall be formed by a continuous roll forming process.
- b. Painting. Factory painting shall be done such that:

The surface of the steel sheet is processed in line through a chromate pretreatment consisting of an alkaline chemical cleaning bath, followed by a chromate conversion coating. Primer is applied immediately after chemical treatment by roller coating, and baked under controlled oven temperature. The reverse side of the sheet is concurrently coated with R-21 epoxy enamel, and baked. A PVC plastisol coating is applied at a minimum dry film thickness of 3.5 mils, and baked in a controlled environment oven. Unless otherwise specified on the drawings, the outside finish color is white.
- c. Siding Meeting Specifications. Super Steel Siding by Alside of Akron, Ohio is among products meeting these specifications. Substitutes require submittals per Paragraph 1A.4 above.

DIVISION 16 - ELECTRICAL
SECTION 16A
BASIC METHODS AND MATERIALS

16A.1 APPLICABLE DOCUMENTS.

a. Federal Documents. The following Federal Specifications in effect on the date of the invitation for bids or request for proposals, form a part of this specification.

(1) WW-C-581 Conduit, Metal, Rigid; and Coupling,
Elbow, and Nipple, Electrical Conduit:

Zinc-Coated

(2) WW-C-563 Conduit, Metal Rigid; Electrical, Thinwall
Steel Type (Electrical Metallic Tubing);
Straight Lengths, Elbows, and Bends

(3) W-F-408 Fittings for Conduit, Metal, Rigid
(Thickwall) and Thin-Wall (EMT)

b. Electrical Codes. The following publications and regulations, in effect on date of the invitation for bids or request for proposals, form a part of this specification and are applicable to the extent specified herein.

(1) NFPA Number 70 National Electrical Code.

(2) The rules and regulations of local utility companies providing service.

(3) Local governing body rules and regulations.

16A.2 REQUIREMENTS.

a. General. The contractor shall install all electrical work in accordance with the applicable drawings and specifications. All electrical work shall be installed to meet the provisions of the current issue of the National Electrical Code, NFPA-70, and all state and local regulations.

16A.2b

b. Contract Drawings.

- (1) Where the electrical drawings indicate or (diagrammatically or otherwise) the work intended and the functions to be performed (even though some minor details are not shown), the contractor shall furnish all equipment, material (other than Government-furnished items) and labor to complete the installation work, and accomplish all the indicated functions of the electrical installation.
- (2) Minor departures from exact dimensions shown on the drawings may be permitted where required to avoid conflict or unnecessary difficulty in placement of the dimensioned item, provided all other contract requirements are met. The contractor shall promptly obtain approval from the FAA Resident Engineer for any such proposed departure.

c. Materials. Materials and equipment, to be acceptable, must comply with all contract requirements. Materials to be furnished by the contractor under this specification shall be new and, unless specified otherwise, the standard products of a manufacturer's latest designs. Wherever standards have been established by Underwriters' Laboratories, Inc., the materials shall bear the UL label.

16A.3 CONDUIT.

- a. Where electrical metallic tubing is shown on the drawings, at exterior or interior locations, it shall be used without substitution.
- b. Except where specified otherwise, conduit exposed to the weather, in concrete, or below grade shall be galvanized rigid steel with threaded joints. All conduit and conduit fittings in contact with earth shall be field coated with asphaltum or have a factory PVC coating.
- c. Except where otherwise specified, conduit used entirely indoors shall be rigid or electrical metallic tubing. Compression type fittings shall be used with metallic tubing.
- d. Minimum size of conduit shall be 3/4-inch unless otherwise noted on the drawings. Each conduit run shall be installed complete before cable is pulled through.
- e. All outdoor connections of conduit to enclosures shall be made with weatherproof hub fittings unless otherwise specified. Indoor connections of rigid conduit to enclosures shall be made with double locknuts and bushings. Refer to grounding section for disconnect switch conduit terminations.

16A.3f

- f. Ends of conduits installed but not used, shall be closed with bushings and pennies. All underground conduit shall be temporarily plugged during construction to prevent entrance of foreign material.
- g. Wherever conduit from outdoors or underground enters an enclosure or junction box, either indoors or outdoors, seal space between conduit and cables with conduit seal.
- h. Exposed conduit shall be installed parallel to or at right angles with equipment and building wall surfaces unless shown otherwise. Field bends shall be avoided where possible, and where necessary shall be made with a hickey or conduit-bending device. Radius of field bends shall not be less than ten times the inside diameter of the conduit. Conduit shall be fastened securely to adjacent members or surfaces with galvanized clamps, straps.
- i. The contractor shall install one #6 copper pull wire in underground duct or conduit which is installed or utilized under this contract. This is in addition to all power or control cables installed under this contract. The pull wire shall be continuous through the duct or conduit, and shall extend five feet beyond each end of the duct or conduit.
- j. Flexible conduit shall be installed where specified on the drawings.

16A.4 GROUNDING.

- a. Equipment, Structures, and Raceways.
 - (1) All metallic non-current carrying parts of electrical equipment (including enclosures) and supporting structures installed under this contract, whether used either for power or control, shall be grounded with an equipment grounding conductor, whether or not shown on the drawings. The grounding conductor shall be sized in accordance with the National Electrical Code, but shall be of larger gauge if so shown on the drawings. In no case shall the grounding conductor be smaller than #12 AWG, unless shown otherwise on the drawings.
 - (2) A service entrance conduit or any other power feeder conduit emerging from below grade and supplying power to another facility or system component shall terminate with grounding bushings at both ends. These requirements apply unless shown otherwise on the drawings.

16A.4a(3)

- (3) The equipment grounding conductor shall be connected to the grounded conductor (neutral) only at the service entrance disconnecting means. The equipment grounding conductor shall be installed in the same conduit as its related branch and feeder conductors, and shall be connected to the ground bus in the branch or distribution panelboard. The equipment grounding conductor shall be connected to all grounding bushings on conduits through which the conductor passes. The equipment grounding conductor shall be connected to all other grounding conductors in enclosures and bodies through which the conductor passes.
 - (4) Where there are parallel feeders installed in more than one raceway, a properly sized equipment grounding conductor shall be installed in each raceway. The metallic conduit carrying the equipment grounding conductor shall be electrically continuous, forming a path parallel to the equipment grounding conductor. Under no circumstances shall the equipment grounding conductor be omitted from the electrical system. Nor shall any separate grounding system such as the signal ground, be used for an alternate grounding system or an alternate path to the grounding electrode, unless so shown on the drawings.
 - (5) All connections to the equipment to be grounded shall be made with a grounding connector specifically intended for that purpose. Connecting screws or mounting bolts and screws are not suitable for use as grounding connections. All ground lugs shall be of a non-corroding material suitable for use as a grounding connection, and must be compatible with the type of metal being grounded. **REMOVE PAINT AND OTHER NON-CONDUCTING MATERIALS FROM SURFACES OF GROUNDING CONNECTIONS.**
 - (6) Unless otherwise specified, control equipment enclosures, pull boxes, and raceways, shall be grounded as above for power wiring.
 - (7) Where surface-mounted square duct, other wireways, or cable tray systems are installed, a separate copper conductor shall be installed in the raceway, and shall be properly bonded to each section. Unless otherwise specified, the minimum size ground conductor shall be #6 green insulated copper.
- b. Service Entrance Disconnect Switches and Breakers. All facility service entrance disconnect switches and breakers shall be grounded as follows:
- (1) The neutral bar or lug shall be grounded with a green insulated copper grounding electrode conductor, running directly to the grounding electrode. The grounding

16A.4b(1)

electrode conductor size shall be in accordance with the NEC, but in no case shall the wire size be smaller than No. 4 AWG.

- (2) The switch box or panelboard enclosure shall be grounded to the grounded neutral bar or lug with a green insulated conductor, or other service grounding means.
- c. Grounding Electrode. Grounding electrodes (rods) shall be copper clad steel, 3/4-inch by 10 feet, except where otherwise specified. The top of the grounding electrode shall be a minimum of 12 inches below finished grade. Lightning down conductors shall be attached to electrodes with exothermic welds only. Shelter perimeter grounding conductors shall be attached to electrodes with exothermic welds only, except in grounding access wells. In a grounding access well, grounding conductors shall be attached with bolted mechanical connectors. Other grounding conductor(s) shall be attached to the electrode with an exothermic weld or by hydraulically crimped compression connectors, as specified below.
- d. Grounding Conductor. All grounding conductors shall be copper. All grounding conductors which are totally above grade shall be green-insulated conductors. All grounding conductors which are either entirely or partially direct-earth buried, shall be #6 AWG bare conductors, unless noted otherwise on the drawings.
- e. Buried Guard Wire. Underground cables which are not completely enclosed in ferrous metal conduit, shall be protected by a #6 AWG bare solid copper guard wire. The guard wire shall be embedded in the soil 10 inches directly above, and parallel to, the highest of the cables in the trench or duct system. The guard wire shall be bonded to the grounding electrode system at each end of the cable run, and to grounding electrodes along the cable run at intervals not exceeding 300 feet. The guard wire shall be connected to the electrodes with exothermic welds, or by hydraulic crimping, as specified below.
- f. Exothermic Process for Connecting Grounding Conductors to Metal Objects. Where the drawings and/or specifications require connection of a grounding conductor to a metal object by exothermic process, the contractor shall supply the correct exothermic welding kit for the application. The mold and cartridge used shall be selected on the basis of size, number, and type of conductors to be connected, composition and surface shape of object, and position in which the weld will be made. Two sources of exothermic welding kits are Thermoweld (Continental Industries) and Cadweld (Erico Products, Inc.). Some of the kits are listed on the tabulation at the end of this section. Regardless of the source of the kits he selects, the contractor shall

16A.4f

submit catalog cuts or other manufacturer information, demonstrating that the kits fit their intended applications on the above described basis. See Paragraph 1A.4 above. The contractor shall provide and use the proper preparation tools in applying the exothermic process to insure an adequate weld. Torch welds and/or brazing will not be permitted. No single-use exothermic weld molds, such as Thermoweld "Single Shot" and Cadweld "One Shot", will be permitted.

- g. Hydraulically Crimped Connections. Grounding conductors (except lightning down conductors, shelter perimeter grounding conductors, and conductors inside a grounding access well) may be connected to grounding electrodes with compression connectors crimped with a force of at least 24,000 pounds. All grounding conductors (except shelter lightning protection system conductors) may be connected to each other with compression connectors crimped with a force of at least 24,000 pounds. Connectors, tools, dies, and crimping procedures shall be compatible to the application and to each other, and shall conform to the manufacturer's catalog and instructions. Each connector shall be clearly marked with catalog number, conductor size, and installation die information. The tooling shall be of the type that embosses or engraves the die index number on the connector in the crimping process. All connectors shall be listed in conformance with Underwriters Laboratories Standard UL467 and the National Electrical Code. Burndy Hyground Compression System connectors, matching tools, and crimping procedures, are one system of products which meet these specifications. Regardless of the source of the connectors, tools, and dies selected, the contractor shall submit catalog cuts or other manufacturer information, demonstrating that these items fit their intended applications as described above. See Paragraph 1A.4 above.
- h. Testing. Electrode grounds shall be tested for resistance intended applications as described above. See Paragraph 1A.4 above. at each location. Resistance to ground for each grounding location shall be 10 ohms or less. If this value is not achieved with the grounding electrodes, as shown on the drawings, additional grounding electrodes, spaced at least 6 feet apart, or electrode extensions of the same construction and diameter, shall be installed until the resistance value does not exceed the maximum of 10 ohms. A tabulated report of the final resistance value at each location shall be provided to the Resident Engineer.

16A.5 SPARE FUSES. Unless specified otherwise, for every fused switch the contractor installs, he shall furnish the Resident Engineer one full set of spare fuses in addition to the fuses installed in the switch. If the drawings require more than one full set, the contractor shall comply with the drawings.

- 16A.6 GROUND FAULT INTERRUPTING RECEPTACLE. All outdoor receptacles provided by the contractor shall be ground fault interrupting duplex receptacles in properly sized weatherproof boxes.
- 16A.7 CABLE ABANDONMENT. Ends of cables to be abandoned shall be buried two feet below grade unless otherwise specified.
- 16A.8 WATERPROOFING CABLE ENDS. All cable ends which will be exposed to weather, water, ground, or corrosive environment prior to termination, shall be sealed against these elements while awaiting termination. This also applies to all cable ends in manholes or handholes. The sealing material shall be properly sized, easily removable heat shrinkable end caps (3M ICEC are acceptable), or electrical tape (see Paragraph 16A.21 below), with an application of brushed-on protective electrical coating.
- 16A.9 CONDUIT AND CABLING FOR ENGINE GENERATOR. Where engine generator standby power will be extended to a facility, conduit shall run continuously, without intermediate manholes or handholes, from the engine generator to the facility. In the continuous conduit, power cables shall be installed without splices from the engine generator bypass switch to the facility service entrance switch.
- 16A.10 ELECTRICAL EQUIPMENT NAME PLATES.
- a. Each of the following types of equipment shall be identified with a name plate showing the functional name of the unit, voltage utilized, one or three phase as applicable, and additional information if specified or requested by the Resident Engineer:
 - Switches (Except Local Lighting)
 - Panelboards
 - Main Circuit Breakers
 - Motor Controllers
 - b. Name plates shall be non-ferrous metal or rigid plastic, stamped, embossed, or engraved with 3/8-inch minimum height letters and numerals. Name plates shall be secured to the equipment with at least two screws, except main breaker plates may be epoxy glued.
- 16A.11 PANELBOARD CIRCUIT DIRECTORIES. The contractor shall clearly and neatly mark panelboard circuit directories, identifying each circuit he establishes, re-establishes, or changes, as to the circuit's function.
- 16A.12 COVERING HOLES IN ENCLOSURES. No electrical enclosure will be accepted which has an unused open hole, except weep holes or vent holes. Holes in enclosures where conduits, bolts, or other objects were removed and not reinstalled, shall be closed with panels of the same material, thickness, color, and shade as the enclosure.

16A.13 SAFETY DISCONNECT SWITCHES AND FUSES. Safety disconnect switches and fuses shall meet the following specifications.

- a. General. Unless specified otherwise, all switches for circuit voltages of 600VAC or less, shall be heavy duty (Type HD), UL listed, and shall bear the UL label. The switches shall be NEMA 1 or NEMA 3R, as required by the drawings or special specifications.
- b. Switch Interiors. All switches shall have switch blades which are fully visible in the OFF position when the switch door is open. All current-carrying parts shall be of high-conductivity copper, designed to carry the rated load without excessive heating. Switches shall have removable arc suppressors where necessary to permit easy access to line side lugs. Lugs shall be front removable and UL listed for 60°C or 75°C, aluminum or copper wires.
- c. Switch Mechanism. Switches shall quick-make, quick-break, such that during normal operation of the switch, the operation of the contacts will not be capable of being restrained by the operating handle after the closing or opening action of the contacts has started. The operating handle shall be an integral part of the box, not of the cover. Switches shall have provisions for padlocking the switches in the OFF position with at least three locks. Switches shall have a dual cover interlock to prevent unauthorized opening of the switch door when the handle is in the ON position, and to prevent closing of the switch mechanism with the door open. The handle position shall indicate whether the switch is ON or OFF.
- d. Enclosures. Covers on NEMA 1 enclosures shall be attached with pin type hinges. NEMA 3R enclosures shall be securable in the open position. NEMA 3R enclosures for switches through 200 amperes shall have provisions for interchangeable bolt-on hubs. Hubs shall accommodate the conduits of the diameters indicated on the drawings. NEMA 3R enclosures shall be manufactured from galvanized steel. All enclosures shall have a gray baked enamel finish, electrodeposited on cleaned, phosphatized steel.
- e. Ratings. All fusible switches rated 100 through 600 amperes at 240 volts, and 30 through 600 amperes at 600 volts, shall have a UL-approved method of field conversion from standard Class H fuse spacing to Class J fuse spacing. The switch also must accept Class R fuses, and have provisions for field installation of a UL-listed rejection feature to reject all fuses except Class R. The UL-listed short circuit rating of the switches shall be 200,000 rms symmetrical amperes when Class R or Class J fuses are used with the appropriate rejection scheme. The UL-listed short circuit rating of the switch, when equipped with Class H fuses, shall be 10,000 rms symmetrical amperes.

16A.13f

- f. Fuses. All fused switches meeting the above specifications shall be fused with dual element, time-delay, UL Class RK5 fuses, of the continuous current rating specified on the drawings. The fuses' interrupting rating shall be at least 10,000 rms symmetrical amperes. Bussmann Fusetron switch fuses are among the products that meet these specifications.
- g. Switches Meeting Specifications. The following eight Square D 240V, single phase, 3-wire switches, are among switches meeting the above specifications:
 - (1) 30-amp-rated, for indoor use, Cat. No. H221A, with field-installable solid neutral assembly Cat. No. H60SNC.
 - (2) 30-amp-rated, for outdoor use, Cat. No. H221AWK, with field-installable solid neutral assembly Cat. No. H60SNC.
 - (3) 60-amp-rated, for indoor use, Cat. No. H222A, with field-installable solid neutral assembly Cat. No. H60SNC.
 - (4) 60-amp-rated, for outdoor use, Cat. No. H222AWK, with field-installable solid neutral assembly Cat. No. H60SNC.
 - (5) 100-amp-rated, for indoor use, Cat. No. H223A, with field-installable solid neutral assembly Cat. No. H100SNC.
 - (6) 100-amp-rated, for outdoor use, Cat. No. H223AWK, with field-installable solid neutral assembly Cat. No. H100SNC.
 - (7) 200-amp-rated, for indoor use, Cat. No. H224A, with field-installable solid neutral assembly Cat. No. H200SNC.
 - (8) 200-amp-rated, for outdoor use, Cat. No. H224AWK, with field-installable solid neutral assembly Cat. No. H200SNC.

16A.14 PANELBOARDS AND CIRCUIT BREAKERS. Panelboards and circuit breakers shall meet the following specifications.

- a. General. Unless otherwise specified, all panelboards for circuits of 240VAC or less, shall be surface mounted, and equipped with bolt-on circuit breakers with frame and trip ratings. Panelboards and circuit breakers shall be UL rated, and shall bear the UL label. When installed as service equipment, panelboards shall be suitable for use as service equipment.
- b. Circuit Breakers. Circuit breakers shall be one-pole or two-pole thermal-magnetic molded-case circuit breakers. The two-pole breakers shall have an integral crossbar to assure simultaneous opening of both poles. Breakers shall have an overcenter, trip-free, toggle-type operating mechanism with quick-make, quick-break action and positive handle indication. Handles shall have ON, OFF, and TRIPPED positions. In addition, trip indication shall include a visible trip indicator appearing in the window of the

breaker case. The circuit breakers shall be able to be installed in the panelboard without requiring additional mounting hardware. Circuit breakers shall be UL-listed in accordance with UL Standard 489 and shall be rated 240 VAC maximum with continuous current ratings as noted on the drawings. Circuit breakers up to but not including an ampere rating of 70 amperes, shall have an interrupting rating of 10,000 rms symmetrical amperes for a 120/240VAC circuit. Circuit Breakers with ampere ratings of 70 amperes or more, shall have an interrupting rating of 22,000 rms symmetrical amperes for a 120/240 VAC circuit. Single-pole 15 and 20-ampere circuit breakers for routine switching of fluorescent lighting loads, shall carry the SWD marking.

- c. Bussing Assembly and Temperature Rise. Panelboard bus structure and main lugs or main circuit breaker shall have current ratings as shown on the drawings. Such ratings shall be established by heat rise tests, conducted in accordance with UL Standard 67. Bus structures shall be insulated. All current-carrying parts shall be of high-conductivity copper, designed to carry the rated load without excessive heating.
- d. Cabinets and Fronts. The panelboard bus assembly shall be enclosed in a steel cabinet. The rigidity and gauge of the steel shall be as specified in UL Standard 50 for cabinets. Wiring gutter space shall be in accordance with UL Standard 67 for panelboards. The box shall be fabricated from galvanized steel or equivalent rust-resistant steel. Each front shall include a door, and shall have a flush, cylinder tumbler-type lock with catch and spring-loaded stainless steel door pull. All panelboard locks shall be keyed alike. Fronts shall have adjustable indicating trim clamps which shall be completely concealed when the doors are closed. Doors shall be mounted with completely concealed steel hinges. Fronts shall not be removable with the door in the locked position. A circuit directory frame and card with a clear plastic covering shall be provided on the inside of the door.
- e. Panelboards Meeting Specifications. The following panelboards are among panelboards which meet the above specifications.

16A.14e(1)

(1) 12-Space Panelboards. Panelboards assembled from the following Square D components, including 100-amp main lug or 100-amp main circuit breaker (CB) interiors with 12 single-pole branch breaker spaces:

	<u>Indoor (NEMA 1)</u>	<u>Outdoor (NEMA 3R)</u>
Interior	NQOD12L100CU (main lugs) NQOD12M100CU (main CB's)	NQOD12L100CU (main lugs) NQOD12M100CU (main CB's)
Enclosure	MH20 (main lugs) MH23 (main CB's)	MH20WP (main lugs) MH23WP (main CB's)
Interior Trim Kit	None	MH20TK (main lugs) MH23TK (main CB's)
Circuit Breakers	QOB style	QOB style

(2) 20-Space Panelboards. Panelboards assembled from the following Square D components, including 100-amp main lug or 100-amp main circuit breaker (CB) interiors with 20 single-pole breaker spaces):

	<u>Indoor (NEMA 1)</u>	<u>Outdoor (NEMA 3R)</u>
Interior	NQOD20L100CU (main lugs) NQOD20M100CU (main CB's)	NQOD20L100CU (main lugs) NQOD20M100CU (main CB's)
Enclosure	MH23 (main lugs) MH26 (main CB's)	MH23WP (main lugs) MH26WP (main CB's)
Interior Trim Kit	None	MH23TK (main lugs) MH26TK (main CB's)
Circuit Breakers	QOB style	QOB style

16A.15 ELECTRICAL ENCLOSURES AND WIREWAYS. Unless specified otherwise, electrical enclosures and wireways shall meet the following specifications.

- a. Material. Electrical enclosures and wireways shall be constructed of code gauge sheet steel.
- b. Corrosion-Resistant Coating. Enclosure and wireway sheet steel shall be coated by ASTM 525 G90 (galvanneal) galvanizing or corrosion-resistant phosphate primer, or both.

16A.15c

- c. Finish. Finish shall be dark gray enamel inside and out, or ANSI 61 gray polyester coating inside and out, or ASA-49 gray epoxy paint inside and out.
- d. Industry Standards.
 - (1) Enclosures. NEMA 1 enclosures shall meet NEMA Type 1 and UL 50 Type 1 standards. NEMA 3R enclosures shall meet NEMA Type 3R and UL 50 Type 3R standards.
 - (2) Wireway. NEMA 1 wireway (including troughs) shall meet NEMA 1 and UL 870 standards. NEMA 3R wireway (including troughs) shall meet NEMA 3R and UL 870 standards.
- e. Hardware. All hardware shall be plated to prevent corrosion.

16A.16 FACILITY AC SURGE ARRESTER. The contractor shall furnish and install an AC surge arrester (power arrester) on the line side of the facility shelter service disconnecting means, as shown on the drawings. The arrester shall meet the following specifications.

- a. Operating Lifetime. The arrester shall safely dissipate the number and amplitude of surges listed in Table 1, below. In this table, the 8x20us waveform defines a transient with a rise time of 8 microseconds (us) from inception to peak value that exponentially decays to 50 percent of peak value 20us after inception.

TABLE 1: LINE-TO-GROUND SURGE LEVELS FOR 120/208V, 120/240V, AND 277/480V AC SERVICES LINES
(Tabulated values are from Table I of FAA-STD-019b, dated August 28, 1990.)

Surge Current Amplitude 8x20 Microsecond Waveform	Number of Surges (Lifetime)	
	Normal Phase Current	
	100A or Less	Greater than 100A
10,000 amperes	1,000 surges	1,500 surges
20,000 amperes	500 surges	700 surges
30,000 amperes	250 surges	375 surges
40,000 amperes	25 surges	50 surges
50,000 amperes	1 surge	5 surges
60,000 amperes	0 surge	2 surges
70,000 amperes	0 surge	1 surge

Clamp (discharge) voltage shall not change more than ten percent over the operating life of the arrester.

b. Operational Characteristics. The arrester shall have the following operational characteristics.

- (1) Reverse Standoff (Maximum Operating) Voltage. Reverse standoff voltage is the maximum voltage that can be applied across arrester terminals with the arrester remaining in an OFF (non-conducting) state. The reverse standoff voltage shall be 125 ± 5 percent of normal line voltage.
- (2) Leakage Current. Leakage current shall not exceed 1 milliamp at reverse standoff voltage.
- (3) Turnon Voltage. Turnon voltage is the minimum voltage across arrester terminals that will cause the arrester to turn on and conduct. Turnon voltage shall not exceed 150 percent of reverse standoff voltage.
- (4) Clamp (Discharge) Voltage. Clamp voltage (discharge voltage) is the maximum sustained voltage that appears across an arrester output terminal while conducting surge currents. For 120/240V and 120/208V arresters, clamp voltage, each phase to ground, either polarity, shall not exceed those shown in the following tabulation:

<u>Surge Current</u>	<u>Clamp Voltage</u>	<u>Surge Current</u>	<u>Clamp Voltage</u>
5,000 amps	400 volts	40,000 amps	900 volts
10,000 amps	480 volts	60,000 amps	1,100 volts
20,000 amps	650 volts	80,000 amps	1,350 volts

- (5) Overshoot Voltage. Overshoot voltage is the surge voltage that appears across the arrester terminals before the arrester turns on and clamps the surge to the clamp voltage. The overshoot voltage shall not exceed two times the arrester clamp voltage for more than 10 nanoseconds.
- (6) Self-Restoring Capability. The surge arrester shall automatically return to the OFF state after surge dissipation when line voltage returns to normal.
- (7) Fusing and Lamps.
 - (a) The input to each arrester phase component shall be internally fused to protect the AC power supply equipment against overload should an arrester device short. This fusing shall not increase the clamp voltage of the arrester. The fusing shall pass the surge current levels given in Table 1 without opening. The arrester internal fusing shall open on application of a steady state current at a level low enough to prevent damage to

16A.16b(7) (a)

the AC power supply. The multiple arrester phase components shall be individually fused. A failed component shall blow its own fuse, and be automatically removed from the circuit, with the remaining components providing continued protection.

- (b) Lamps. Each phase shall have two indicator lamps in parallel, to continuously monitor the arrester condition. The lamps shall be coordinated with the fuses such that the lamps dim or go out when the last arrester component remains. The arrester elements shall be connected line-to-neutral.
- c. Composition and Construction. All components of the arrester shall be assembled and mounted in a single NEMA 4 waterproof enclosure. Heavy duty, screw-type studs shall be provided for all input and output connections. The arrester elements shall be connected line-to-neutral. The arrester shall have an internal means of easily disconnecting incoming power, so the arrester may be maintained without disconnecting facility power. The arrester elements shall be electrically isolated from the enclosure to a minimum of 10 megohms resistance. The enclosure door shall be hinged and electrically bonded to the enclosure when shut. The hinges shall not be used to provide electrical bonding. Indicator lamps shall be mounted on the front door. Fuses, lights, fuse wires, and arrester components shall be readily accessible for inspection and replacement.
- d. Arrester Meeting Specifications. For 120/240V, single phase, 60Hz applications, the Lightning Protection Corporation (Goleta, California) Model No. LPC 20206-7 AC surge arrester is one of the products that meet the above specifications. If the contractor intends to furnish a substitute, or if a different power configuration must be accommodated, the contractor shall submit to the Contracting Officer, full manufacturer's literature on the substitute arrester, and shall not procure the substitute before receiving the Contracting Officer's approval. See Paragraph 1A.4 above.
- e. Installation. The arrester shall be installed as close as practical to the facility service disconnecting means, but not more than 12 inches away from the disconnecting means. Wiring connections shall be on the line side of the service disconnecting means.
 - (1) Phase Cables. Surge arrester phase lugs shall be connected to corresponding phase terminals of the service disconnecting means with insulated #4 AWG (minimum gauge) stranded copper cable. These cables shall be as short and shall run as directly as feasible, without loops, sharp bends or kinks.

16A.16e(2)

(2) Surge Grounding Cable. The surge grounding cable shall be routed as directly as feasible, without loops, sharp bends or kinks, from the surge grounding terminal:

- (a) To the nearest grounding electrode, or
- (b) To the neutral bus in the service disconnecting means, if so shown on the drawings.

The surge grounding cable shall be insulated #4 AWG (minimum gauge) stranded copper cable. This cable shall be color coded white when connected from the arrester to the service disconnecting means.

(3) Equipment Grounding Conductor. The surge arrester enclosure shall be connected to the ground bus in the service disconnecting means enclosure with a #6 AWG green insulated copper cable.

16A.17 SHELTER ENVIRONMENTAL AND LIGHTING EQUIPMENT. If required on the drawings, equipment for an equipment shelter (building) nominally sized 10'x12', shall meet the following specifications.

- a. Vent Fan. For a MALSR shelter, the vent fan shall be at least 1/25 HP, and shall move at least 424 CFM at zero gauge pressure. Greenheck Model GW-75-D is one of the products that meet these specifications. For an ILS shelter, the vent fan installation shall be supplemented with a power damper and two-position damper motor. The Honeywell D640 power damper with two-position damper motor Honeywell M436A116, is one of the products that meet these specifications. The intake damper for the ILS shelter shall be a power damper with two-position damper motor identical to the vent fan power damper.
- b. Vent Fan Thermostat. The vent fan thermostat shall be a 120VAC wall-mounted airswitch controller operating in a temperature range from at least 35° to 95°F. Honeywell Part No. T651A is one of the products that meet these specifications. This item applies to buildings without environmental control panels, e.g., MALSR and ILS marker shelters.
- c. Heater. The heater shall be a 240V, 4,000-watt wall-mounted electric heater with surface mounting box. The QMark Cat. No. AWH-4404 heater is one of the products that meet these specifications.

16A.17d

- d. Heater Timer Unit. The heater timer unit shall consist of a 1-hour 240-volt manual timer, and contactor with 208/240-volt coil and 30-amp rated contacts, mounted on and in a minimum 12"x12"x4" NEMA 1 hinged cover box with matching mounting panel. The following components are among components that meet these specifications: Timer, Dayton Stock No. 6X546; contactor, Honeywell Part No. R4243B1046; enclosure, Hoffman Cat. No. A-12N124, with A-12N12P mounting panel. The heater timer unit is applied to buildings without environmental control panels, e.g., MALSR and ILS marker shelters.
- e. Air Conditioner. The air conditioner shall be nominally 240V (unless specified otherwise on the drawings), front air discharge model, with EER of at least 9.0, and shall have either a through-wall sleeve or a slide-out chassis. Air conditioners are applied to buildings with environmental control panels, e.g., ILS localizer and glide slope shelters.
- f. Interior Light Fixture and Lamps. Each interior light fixture shall be surface mounted, 120-volt, having a white-painted steel chassis and a light-controlling plastic lens enclosure. The lens enclosure shall be of a wraparound style which illuminates the ceiling as well as the room. The fixture shall be nominally four feet long, and shall accommodate two 48"-long T-8 fluorescent lamp tubes. The ballast shall have a radio frequency suppressor. The ballast shall operate normally at temperatures above 20°F. The lamp tubes shall be 32-watt 48"-long T-8 fluorescent lamp tubes, each with an initial rating of 2,850 lumens. The Holophane Prismawrap Cat. No. M7100-4-1-A-6 light fixture is among fixtures which meet these specifications. The following 32-watt lamp tubes are among lamps which meet these specifications: General Electric Trimline, Philips TL70, and Sylvania Octron.
- g. Exterior Light Fixture. The exterior light fixture shall be a 50-watt high pressure sodium unit, rated for 24,000-hour lamp life, having a cast aluminum housing, and a photocontrol installed inside the housing. Holophane Wallpockette luminaire, Cat. No. WP-2-A-050HP-12-GR-P, is among products which meet these specifications.

16A.18 SHELTER LIGHTNING PROTECTION EQUIPMENT. All shelters (buildings) shall have a lightning protection system installed per the requirements of the Lightning Protection Code, National Fire Protection Association (NFPA 78), and Underwriters Laboratories Master Labeled System (UL96A). Specific lightning protection equipment items shall meet the following specifications. Catalog numbers given in a through k below, are of Thompson Lightning Protection, Inc. of St. Paul, Minnesota.

- a. Air Terminal Point. Air terminal points shall be nickel-tipped copper, 1/2" diameter x 36" long. Cat. No. 660 meets these specifications.

16A.18b

- b. Point Bracket. For a roof ridge, the point bracket shall be made of pressed copper, shall bend to fit any roof slope, and shall hold the point and cable slightly above the center of the roof ridge. The bracket shall have a pressure cable clamp, and a stud to engage the point. Cat. No. 532 meets these specifications.
- c. Air Terminal Brace. The air terminal brace shall be a 36"-long galvanized tripod assembly, with legs adjustable to accommodate any roof slope. Cat. No. 83 meets these specifications.
- d. Roof and Down Conductors. Roof and down conductors shall each have 32 strands of #17 copper wire, 7/16" overall diameter, braided smooth twist, 65,500 circular mils, and a net weight of 215 pounds per 1000 feet. Cat. No. 32 meets these specifications.
- e. Ridge Cable Support. Ridge cable supports shall be pressed copper cable supports at least 2" wide, to hold the roof cable above the top of the roof. The ridge cable supports shall be sized to accommodate the roof conductor. Cat. No. 533 meets these specifications.
- f. Cable Holder. Cable holders shall be 1"-wide copper bent-strap type loops with 1/4" mounting holes. The cable holders shall be sized to accommodate the roof conductor. Cat. No. 166XX meets these specifications.
- g. Parallel Clamp. Parallel clamps shall be bronze 2"-long clamps for connecting two conductors together, one conductor of maximum diameter 1/2", and the other conductor from 1/6" dia to 5/16" dia. Cat. No. 565 meets these specifications.
- h. Flexible Bonding Strap. Flexible bonding straps, for connecting steel doors to steel door frames, shall be braids each composed of 480 #30 copper wires, with flat bronze or copper connectors crimped on at each end. The connectors shall have holes to take either 5/16" or 3/8" machine screws.
- i. Pipe Clamp. Pipe clamps shall be adjustable tinned bronze clamps for bonding cables to pipes, and fitting pipes up to and including 1 1/4" O.D., and cables up to and including 1/2" diameter. Cat. No. 240 meets these specifications.
- j. Bonding Equipment. Bond the steel siding, vent fan, hood, door frame, junction boxes, and any miscellaneous exterior metal objects to down conductors. If included, air conditioners, junction boxes, and flight check antenna masts shall be likewise bonded. Use the following equipment to perform the bonding:

16A.18j(1)

- (1) Bonding Plate. Bonding plates shall be 8-sq. inch tinned bronze plates with 2"-long pressure type cable connectors, designed to bond a continuous run of cable to metallic objects along their path. Each plate shall have two holes fitting sheet metal screws or 1/4" machine screws. Cat. No. 702 meets these specifications.
 - (2) Bonding Conductor. Bonding conductor shall be minimum #6 bare soft drawn copper, 1/6" dia, 26,250 circular mils, net weight 80 pounds per 1000 feet. Cat. No. 14X (#6 bare solid) and Cat. No. 509X (#4 bare solid) meet these specifications.
- k. Ground Rod Clamps. In the grounding access well, the #6 grounding electrode conductor shall be connected to the 3/4"-diameter grounding electrode with a bronze 2-bolt ground rod clamp. Cat. No. 519 meets these specifications. In the grounding access well, the 4/0 counterpoise cable (perimeter ground) shall be connected to the 3/4"-diameter grounding electrode with a bronze clamp which will accept one vertical cable and one horizontal cable. Cat. No. 693 meets these specifications.
- l. Grounding Access Well Frame and Lid. If shown on the drawings, the frame and lid of the grounding access well shall fit snugly into the opening of a 15"-diameter corrugated pipe. The frame and lid shall be ASTM A48 Class 35B gray cast iron. The lid shall be solid, not of an open construction. Neenah Foundry Co. (Neenah, Wisconsin) Cat. No. R-5900-B is one of the products that meet these specifications.

16A.19 CONTROL CABLE TERMINAL STRIPS. Unless specified otherwise, contractor-furnished control (telephone) cable terminal strips shall be units assembled from compatible components all from the same manufacturer. The individual blocks of the strips shall be miniature style (1/4" O.C.) nylon blocks with screw-activated tubular conductor clamps. The blocks shall be rated for a maximum voltage of at least 300 volts and a maximum current of at least 30 amperes. The conductor clamps shall accept wire sizes at least from #14 to #22. Stab-in wire connection blocks shall not be used. The blocks shall be mounted in a mounting channel. The assembled strip of blocks shall have a marking strip and holding plugs or end barriers. For terminating control cables on these strips, see Paragraph 16F.7 below. The following terminal strip components are among components which meet these specifications:

16A.19a

- a. Buchanan: Blocks No. 125 mounted in channel No. 12 with clamps No. 11. Marking strip No. 15. Holding plug No. 16.
- b. Square D: Blocks No. GM-3, with mounting channel and marking strip of the GH series, with end barrier No. GM3B.

16A.20 FRANGIBLE COUPLINGS.

- a. Material Specification. Unless specified otherwise, contractor-furnished frangible couplings shall be 2" diameter cast aluminum couplings having a hexagonal clamping ring. The couplings shall accommodate 2"-diameter EMT conduit, and shall meet Military Specification MS-17814-1. Frangible coupling Cat. No. 961A by Multi Electric Mfg., Inc. of Chicago, Illinois, is one of the products that meet these specifications.
- b. Thread Remediation. Often, the conduit threads of frangible couplings (both contractor-furnished and Government-furnished) are cast with mismatched halves. Often, this imperfection causes the threads to bind in the rigid coupling threads conduit threads of the required mating object), before the required engagement is reached, even when anti-seize compound is used. When this binding occurs, the contractor shall rework the frangible coupling threads to achieve the required thread engagement. This remediation may consist of rethreading with a straight conduit thread die, and/or of grinding off the threads on the two diametrically opposite sides of the thread helix where the cast thread discontinuity is found. This remediation must continue until the required thread engagement is achieved. All burrs and galls must be removed from the reworked threads.
- c. Installation. For approach lighting systems, see Paragraph 13A.2c. For VASI, REIL, PAPI, and RVR, see Paragraph 13C.2b.

- 16A.21 ELECTRICAL TAPE. Unless specified otherwise, electrical tape shall meet the following specifications. The tape material shall be based on PVC polyvinyl and/or PVC copolymers. The tape shall have a rubber-based, pressure-sensitive adhesive. The tape shall be 8.5 mils thick, and be UL listed and marked per UL Standard 510 as "Flame Retardant, Cold and Weather Resistant." The tape must be applicable at temperatures ranging from 0°F through 100°F (-18°C through 38°C). The tape shall be classified for both indoor and outdoor use. The tape shall be compatible with synthetic cable insulations, jackets, and splicing compounds. Scotch Super 88 Vinyl Electrical Tape by 3M is one of the products that meet these specifications.

16A.22 PRE-STRETCHED RUBBER TUBING. Pre-stretched rubber tubing shall be open-ended tubular rubber sleeve, factory expanded and assembled onto a removable core. The tubing is supplied for field installation in this pre-stretched condition. The tube is positioned for installation over an inline connection, terminal lug, sleeve splice, or other cable insulation discontinuity requiring protection. Then the core is removed, allowing the tube to shrink to produce a waterproof seal.

The tubing shall be made of EPDM (ethylene propylene diene methylene) rubber containing no chlorides or sulfurs. The tubing must be capable of operation at emergency overload cable temperatures of 130°C. It must be usable without additional covering or adhesive, both indoors and outdoors, in overhead, direct buried or submerged applications, on cables rated up to 1,000 volts. The tubing must be applied without additional heat or flame and, when applied per the manufacturer's instructions, be immediately energizable. It must not be adversely affected by moisture, mild acids or alkalis, ozone or ultraviolet light. It must conform to the requirements of ANSI C119.1 1974, appropriate sections of Western Underground Guide 2.14 and UL 486D. The tubing must have been accepted by the U.S. Department of Agriculture, Rural Electrification Administration (REA), for both submersible and aerial application. PST Cold Shrink Connector Insulators 8420 Series by 3M are among products which meet these specifications. All applications must be performed per the manufacturer's instructions.

16A.23 FIRE AND ARC PROOFING. Fire and arc proofing shall consist of a flexible conformable unsupported (having no adhesive) intumescent elastomer. The intumescent property causes the tape to expand in fire, thus providing an insulating firewall between the flame and cable. The tape shall be not less than .030 inches thick. The tape shall be capable of over 100% elongation. The tape shall be non-corrosive to metallic cable sheaths. It shall be compatible with synthetic cable jackets such as semi-conducting URD type, polyethylene, and PVC. The tape shall be self-extinguishing, i.e., shall not support combustion. The tape shall not deteriorate when subjected to water, salt water, gases, and sewage. The wrapped tape shall be secured by a band consisting of two layers (the second wrapped directly over the first) of glass cloth electrical tape at both ends of the fire and arc proofing wrap. The completed installation of a single half-lapped layer of fire and arc proofing shall be capable of withstanding a high 60 Hz current fault arc temperature of 13,000°K for 70 cycles. Scotch 77 Fire and Arc Proofing tape secured with Scotch 69 Glass Cloth Electrical Tape are among products that meet these specifications, when applied per the manufacturer's instructions. All applications must be performed per the manufacturer's instructions.

16A.24 CABLE CONNECTOR PROTECTION.

- a. Primary Connections. Where single-conductor plug and receptacle cable connectors are joined in light bases or other underground enclosures, the joint shall be sealed with heat-shrinkable tubing specifically designed for this purpose. Each tubing unit shall consist of a polyolephin heat-shrinkable sleeve with sealant at each end. The tubing shall meet the performance specifications of ANSI C-119.1 and Western Underground Guide (2.5, 2.4), and shall be REA listed under "secondary" tap or splice cover, submersible.

The sleeve is placed over the cable connectors, their joint, and a short length of cable at the ends of the connectors. The sleeve is shrunk with a torch or heat gun, with heat applied from the center of the sleeve toward the ends, to avoid trapping air. The sleeve shrinks under the heat, to conform to the shape of the connectors and the cables. The sealant at the ends of the sleeve forms a watertight seal around the cables. These sleeves shall be applied to cable connector joints between two isolation transformer primary leads, a primary lead and a cable, or two cables, wherever these joints are specified in a light base or other underground enclosure. The sleeves must be of a type designed for easy removal by applying a small amount of heat, slitting the sleeve with a knife, and peeling away the sleeve. Airport Lighting Connector Protection tubing, Series APL-823A, by Sigmaform Corporation of Vicksburg, Mississippi, is one of the products that meet these specifications. Substitutes require submittals per Paragraph 1A.4 above.

- b. Secondary Connections. Where two-conductor plug and receptacle cable connectors are joined in light bases or other underground enclosures, the joint between the two connectors shall be sealed with at least two layers of electrical tape and an application of protective electrical coating. Where two-conductor plug and receptacle connectors are joined in a frangible coupling, apply no tape or any other protection.

16A.25 ELECTRICAL COATING. Cable connections, splices, or other joints wrapped with plastic electrical tape, shall be sealed with an electrical coating meeting Military Specification MIL-P-18623. Scotchkote electrical coating is among the products meeting this specification.

- 16A.26 COMMERCIAL METAL FRAMING. Where specified for mounting of electrical equipment or other purpose, the contractor shall furnish and install commercial metal framing. The channel framing members shall be formed from strip steel, with one side of the channel having a continuous slot with inturned lips. The principle of attachment is application of nuts which engage the inturned lips of the channel. For outdoor applications, framing members shall be hot-dip galvanized per ASTM Specification A-123 or A-153. For indoor applications, 16A.26 framing members shall be factory coated with enamel or epoxy coatings, or electro-galvanized per ASTM Specification B633, or pre-galvanized with a G90 zinc coating per ASTM Specification A-525. Uncoated framing members, or framing members coated only with oil, are not acceptable. Properly sized and matched channel framing members, fittings, and hardware from Unistrut Corporation of Wayne, Michigan, and from B-Line Systems, Inc. of Highland, Illinois are among products meeting the above specifications. Installation shall be in accordance with manufacturer's instructions.
- 16A.27 EXPANSION COUPLING. Where shown on the drawings, rigid metal conduits which emerge vertically from below grade to make a direct connection to an above-grade junction box or structure, shall be fitted with an expansion coupling. The purpose of the expansion coupling is to accommodate relative vertical movement, such as the movement due to frost heave. The coupling shall be rigid metal, and shall be threaded onto the rigid conduits at both ends of the coupling. The coupling must accommodate 8 inches of movement, unless space limitations prohibit installing such a coupling. If there are such space limitations, a coupling allowing only 4 inches of movement may be substituted. For expansion couplings accommodating 8 inches of movement, couplings of the Appleton XJ-8 series are among couplings meeting these specifications. For expansion couplings accommodating 4 inches of movement, couplings of the Appleton XJ-4 series are among couplings meeting these specifications. Electrical continuity across the expansion coupling must be maintained by installing a bonding jumper. Bonding jumpers of the Appleton XJB-4 series meet these specifications for 4"-movement expansion couplings. Bonding jumpers of the Appleton XJB-8 series meet these specifications for 8"-movement expansion couplings.

CADWELD EXOTHERMIC WELDING KITS

GROUNDING ELECTRODE	CABLE SIZE (RUN WIRE)	CABLE SIZE (TAP WIRE)	CONNECTION DESIGNATION	CONNECTION TYPE	WELD METAL	CONNECTION DESCRIPTION
Copperclad	#6 Solid	#6 Solid	GR	GRT-181G	32	These are connections in which a horizontal copper cable terminates at the top of a vertical 3/4" grounding electrode.
			GR	GRT-181H	32	
			GR	GRC-188D ²	115	
Stainless Steel	#6 Solid	#6 Stranded	GR	GRT-331G	32	
			GR	GRT-331H	32	
			GR	GRC-338D ²	115	
Copperclad	#6 Solid	#6 Stranded	GT	GTP-181G	45	These are connections in which a through run cable connects to the top of a vertical 3/4" grounding electrode.
			GT	GTP-181H	45	
Stainless Steel	#6 Solid	#6 Stranded	GT	GTP-331G	45	
			GT	GTP-331H	45	
Copperclad	#4/0 Stranded	#4/0 Stranded	GY	GYE-182Q	150	These are connections in which a through run cable connects to the side of a vertical 3/4" grounding electrode.
			GY	GYE-332Q	150	
Copperclad	#6 Solid	#6 Stranded	PC	PCC-1G1G	25	PC designates parallel connections of horizontal cables, with the tap on top.
			PC	PCC-1H1H	25	
			PC	PCC-1V1G	32	
			PC	PCC-1V1V	65	
			TA	TAC-2Q2Q	150	
			TA	TAC-2Q8C	115	
Stainless Steel	#4/0 Stranded	#4/0 Stranded	TA	TAC-2Q8F	150	TA designates tee connections of horizontal run and tap cables.
			TA	TAC-2Q8C	115	
			TA	TAC-2Q8F	150	
			TA	TAC-2Q8C	115	
			TA	TAC-2Q8F	150	
			TA	TAC-2Q8C	115	

NOTE: 1. Lightning conductor, #2 copper stranded 17 AWG, 59500 CM, 187.5 lb/1000 ft., IPC #32S, approximately 15/32" diameter.

2. Use Cadweld E-Z Change Handle, Catalog Number L-160, when using this mold.

DIVISION 16 - ELECTRICAL
SECTION 16B
600-VOLT POWER CABLE FOR UNDERGROUND INSTALLATION

- 16B.1 SCOPE. This section covers the material requirements for all contractor-furnished single-conductor 600-volt power cable required for direct earth burial installation. Installation of power cable is covered in Section 16F.
- 16B.2 GENERAL REQUIREMENTS. Cable construction shall include copper single conductor and XLP (thermosetting crosslinked polyethylene) insulation. Cable shall be UL listed as Type USE or RHW or RHH for use in circuits not exceeding 600 volts at conductor temperatures of 90°C for continuous normal operation, 130°C for emergency overload conditions, and 250°C for short circuit conditions. Cables shall be suitable for direct burial and above-grade installation in wet or dry locations.
- 16B.3 APPLICABLE SPECIFICATIONS.
- a. Underwriters Laboratories Standard 854 for Service Entrance Cables.
 - b. Underwriters Laboratories Standard 44 for Rubber-Insulated Wires and Cables.
 - c. ICEA Publication Number S-66-524, NEMA Publication Number WC7 for Crosslinked Polyethylene-Insulated Wire and Cable.
 - d. Federal Specification J-C-30A.
- 16B.4 CABLE CONSTRUCTION. Cable characteristics shall include the following materials and construction:
- a. Conductors. Conductors shall be solid or Class B stranded annealed uncoated copper, per UL Standards 854 and 44.
 - b. Separator. A suitable separator over the conductor may be used at the option of the manufacturer.
 - c. Insulation. Each conductor shall be insulated with XLP (crosslinked polyethylene) complying with the physical and electrical requirements of UL Standard 854 for Type USE and UL Standard 44 for Types RHW and RHH and Paragraph 3-6 of ICEA Publication Number S-66-524. The insulation shall be applied lightly to the conductor and shall be free-stripping.
- 16B.5 IDENTIFICATION. The cable shall be identified by surface marking indicating manufacturer's conductor size and metal, voltage rating, UL Symbol and type designation, and year of manufacture.

- 16B.6 TESTS. Cable shall be tested in accordance with requirements of UL Standard 854 for Type USE, UL Standard 44 for Types RHW and RHH, and ICEA Publication Number S-66-524, Paragraph 3.6.
- 16B.7 DATE OF MANUFACTURE. Year of manufacture of all cable shall be no earlier than one calendar year immediately preceding contract award date.
- 16B.8 PACKAGING. All cable shall be provided on wooden or steel reels, and ends of all cable shall be sealed to prevent entry of moisture. All reels shall identify type, length, and year of manufacture of cable packaged on such reels. All such identification shall be clearly provided by the manufacturer.

DIVISION 16 - ELECTRICAL
SECTION 16C
600-VOLT ARMORED POWER CABLE

- 16C.1 DESCRIPTION. This section covers the material requirements for all contractor-furnished 600-volt 3-conductor armored power cable required for direct earth burial installation. Installation of power cable is covered in Section 16F.
- 16C.2 GENERAL REQUIREMENTS. Cable construction shall include three copper conductors with XLP (thermosetting crosslinked polyethylene) insulation, galvanized steel interlocking armor, and PVC jackets under and over armor. Cable shall be UL listed as type MC for use in circuits not exceeding 600 volts phase to phase at conductor temperatures of 90°C in dry locations, or 75°C in wet locations, 130°C for emergency overload conditions, and 250°C for short circuit conditions in wet or dry locations. Cables shall be designed and labeled for direct burial use.
- 16C.3 APPLICABLE SPECIFICATIONS. The following specifications form a part of this specification to the extent specified herein:
- a. UL Standard 1569 for Metal-Clad Cables.
 - b. UL Standard 44 for Rubber Insulated Wires and Cables.
 - c. ICEA Publication Number S-66-524, NEMA Publication Number WC7 for Crosslinked-polyethylene insulated Wire and Cable.
 - d. IEEE 383 Type Tests of Class 1E Electric Cables, Field Splices and Connections for Nuclear Power Generating Stations.

CABLE CONSTRUCTION. Cable construction shall include the following materials and construction:

- a. Conductors. Class B stranded annealed uncoated copper per Part 2 of ICEA.
- b. Separator. A suitable separator over the conductor may be used at the option of the manufacturer.
- c. Insulation. XLP crosslinked polyethylene meeting the requirements of ICEA Part 3, Paragraph 3.6 and Type XHHW requirements of UL 44. Average thickness of insulation shall be as specified in UL 44 for Type XHHW conductors and in the Table 3-1 of ICEA. Minimum thickness at any point shall be not less than 90% of the specified average thickness.

16C.4d

- d. Phase Identification. Insulated phase conductors shall be printed with the numeral "1", "2", and "3" on the surface of the insulation.
- e. Assembly. Three phase conductors shall be cabled together with a Class B stranded, uncoated copper grounding conductor and suitable nonhygroscopic fillers to make round. Length of lay shall not exceed 35 times the phase conductor diameter. The grounding conductor shall comply with the requirements of UL Standard 1569. A suitable nonhygroscopic cable tape shall be applied over the assembly.
- f. Inner PVC Jacket. PVC meeting the requirements of ICEA, Part 4 and the Sunlight Resistant requirements of UL 1569. Average jacket thickness shall be in accordance with UL 1569. Minimum thickness at any point shall be not less than 70 percent of the specified average thickness.
- g. Armor. Galvanized steel interlocked armor shall be applied over the inner PVC jacket. Armor shall be in accordance with UL requirements for Type MC cable and Part 4 of ICEA.
- h. Outer PVC Jacket. PVC meeting the requirements of ICEA, Part 4 and the Sunlight Resistant requirements of UL 1569. Average jacket thickness shall be in accordance with UL 1569. Minimum thickness at any point shall be not less than 70 percent of specified average thickness.

16C.5 TESTS. Conductors and completed cables shall be tested in accordance with UL requirements for Type MC cables having XHHW conductors.

16C.6 IDENTIFICATION. Cable shall be identified by surface marking indicating manufacturer's identification, conductor size and metal, voltage rating, UL symbol and type designation, year of manufacture, and "direct burial" designation.

16C.7 DATE OF MANUFACTURE. Year of manufacture of all cable shall be no earlier than one calendar year immediately preceding contract award date.

16C.8 PACKAGING. All cable shall be provided on wooden or steel reels, and ends of all cable shall be sealed to prevent entry of moisture. All reels shall identify type, length, and year of manufacture of cable packaged on such reels. All such identification shall be clearly provided by the manufacturer.

16C.9 SUBMITTALS. For the specific cable that the contractor proposes to use, the contractor shall submit the manufacturer's complete cable specifications, including compliance with all cable requirements, codes, and standards referenced herein, and a drawing showing cable construction details. Submit these items, and receive the Contracting Officer's approval before installing any cable specified herein. See Paragraph 1A.4 above.

DIVISION 16 - ELECTRICAL
SECTION 16E
CONTROL CABLE

16E.1 SCOPE. This section covers the material requirements for all contractor-furnished exterior standard and gopher-resistant filled control (telephone) cable to be installed as shown on the drawings. Installation of control cables is covered in Section 16F.

16E.2 APPLICABLE SPECIFICATIONS.

- a. United States Department of Agriculture, Rural Electrification Administration (REA), Specification PE-39 for "Filled Telephone Cable" (Bulletin 345-67) latest edition, including all addendums and attachments thereto, forms a part of these specifications and is applicable in its entirety.
- b. Certain requirements, specified herein, supplement the requirements of Specification PE-39, and shall receive special attention by the cable manufacturer and contractor.

16E.3 GENERAL REQUIREMENTS.

- a. Definition. The term "control cable" used throughout these specifications and on the project drawings is a general FAA term for cable used to transmit voice and control functions. The required cable is termed "telephone" or "telephone exchange" cable by the cable manufacturing industry.
- b. Quality. All control (telephone) cables shall be the standard products of a single major cable manufacturer and shall be designed and manufactured according to the highest industry standards. All cables shall be free of any imperfection which could affect serviceability and design life.

16E.4 STANDARD CABLE CONSTRUCTION. Cable requirements, complying with these specifications and Specification PE-39, include the following materials and construction.

- a. Conductors. #19 AWG solid annealed copper.
- b. Conductor Insulation. Solid polypropylene or polyethylene color coded in accordance with telephone industry "standard" coding.
- c. Twisted Pairs. Individual conductors twisted into pairs with varying lays to minimize crosstalk.
- d. Forming of Cable Core. Cables having 25 pairs or less are assembled into a single cylindrical group. Cables having more than 25 pairs are assembled in units, each individually identified by color coded unit binders.

16E.4e

- e. Filling Compound. Water resistant non-hardening compound to fill and seal all interstices between the conductor pairs.
- f. Core Covering. Non-hygroscopic dielectric tape.
- g. Flooding Compound. Water resistant and bonding compound to fill all voids between the core wrap and shield and between the shield and jacket.
- h. Shield. Corrugated electrically continuous and longitudinally applied 0.008 inch coated aluminum or 0.005 inch copper.
- i. Jacket. High molecular weight polyethylene or high-molecular weight ethylene copolymer.

16E.5 GOPHER-RESISTANT CABLE CONSTRUCTION.

- a. General. If gopher-resistant cable is required by drawings or special specifications, cable construction shall comply with all construction requirements for standard cable in Subsection 16E.4 above (including conformance with REA Specification PE-39) excepting for item h, "Shield", which shall comply with the following:
- b. Gopher-Resistant Shield. Corrugated electrically continuous and longitudinally applied overlapping metal shield consisting of one of the following materials:
 - (1) 0.010 inch copper.
 - (2) 0.006 inch copper/stainless steel/copper bimetallic alloy.
 - (3) 0.007 inch Alloy 194 for 6 pr #19 cable.
 - (4) 0.006 inch Alloy 194 for cables larger than 6 pr #19.
 - (5) 0.008 inch coated aluminum with 0.006 inch coated steel.

16E.6 CABLE IDENTIFICATION. In accordance with Specification PE-39, all cable shall have jacket printed at periodic intervals with the name of the manufacturer, manufacturer's standard designation, year of manufacture, number of pairs, conductor gauge, sequential length marks, and notation signifying compliance with Specification PE-39 (if not clearly referenced in the manufacturer's submittals). In addition, the gopher-resistant shield shall be clearly identified.

16E.7 DATE OF MANUFACTURE. Year of manufacture of all cable shall be no earlier than one calendar year immediately preceding contract award date.

16E.8 PACKAGING. In accordance with Specification PE-39, all cable shall be stored and shipped on reels affording the required protection. Thermal wrapping shall be provided and ends of all cables shall be capped against exposure to moisture. All reels shall be labeled by the manufacturer and shall bear the manufacturer's name, year of manufacture, REA cable designation, description of cable, actual shipping length, and identification referenced to tests of record as required herein.

16E.9 TESTS.

- a. All project cable furnished shall satisfy all test requirements of Specification PE-39. Records of all such tests shall be retained by the manufacturer, according to Paragraph 29 of Specification PE-39, and shall be promptly made available to the Federal Aviation Administration upon request. All tests shall be specifically and clearly referenced to all reels of cable furnished.
- b. Basic cable design, for all project cable furnished, shall have proven acceptable to REA through "qualification testing" according to Paragraph 27 of Specification PE-39.
- c. Electrical tests, according to paragraph 28.1 of Specification PE-39, shall be performed on 100 percent of all project cable furnished.
- d. Quality assurance (capability) tests, according to Paragraph 28.2 of Specification PE-39, shall be performed on such periodic production basis so as to represent quality of all project cable furnished.

16E.10 SUBMITTALS. Prior to procuring any cable specified herein, the contractor shall submit the following documents for the specific cable that the contractor proposes to use, to the Contracting Officer, and receive written approval therefrom (see Paragraph 1A.4 above):

- a. Manufacturer's complete cable specifications, including manufacturer's statement of compliance with REA Specification PE-39.
- b. Drawing showing cable construction details.

DIVISION 16 - ELECTRICAL
SECTION 16F
CABLE INSTALLATION

16F.1 DESCRIPTION OF WORK. The extent of work is indicated on the drawings and by the provisions of this section. Included in this section are installation, splicing, and testing of power and control cables.

16F.2 GENERAL REQUIREMENTS.

- a. Service Interruptions. Existing sources of power and control are indicated on the drawings. For circuits actively in use, the contractor shall coordinate temporary interruptions of service with users and suppliers, the Resident Engineer, and the airport management.
- b. Cable Protection.
 - (1) All cable ends which will be exposed to weather, water, ground, or corrosive environment prior to termination, shall be sealed against these elements while awaiting termination or splicing. This requirement also applies to all cable ends in manholes or handholes. The sealing material shall be properly sized, easily removable heat shrinkable end caps (3M ICEC are acceptable), or electrical tape (see Paragraph 16A.19 above), with an application of brushed-on electrical coating.
 - (2) Cables shall not be bent at radii less than radii recommended by the manufacturer, or 10 times cable diameter (12 times diameter for armored cable), whichever is greater. Any cables damaged in any way by sharp bending shall be replaced.
 - (3) Special care should be taken when working with filled cables, especially when the temperature is below 35°F. This type of cable becomes more difficult to bend and work as the temperature decreases, and there is a possibility of cable damage at temperatures near 0°F.
- c. 600-Volt Wire and Cable Color Coding.
 - (1) All single conductor 600 volt wire and cable for 120/240 volt power circuits shall be color coded black for line 1, red for line 2, and white for the neutral.
 - (2) For conductor sizes smaller than #8 AWG, conductor insulation shall be color coded. For sizes #8 AWG and larger, and for armored power cable, colored tape shall be used to identify the conductors if insulation is not color identified.

16F.2c(3)

- (3) Conductors shall be color-coded in junction boxes, square duct, terminal boxes, or any other place accessible to view. In no case shall green be used for other than grounding, nor white for other than the system grounded (neutral) conductor.
- d. Designation of Armored Cable. On drawings and other contract documents, the letter A immediately following the AWG number of a cable, indicates that the cable is armored (e.g., 3/C #8A, 600V).

16F.3 DIRECT-EARTH BURIAL CABLE INSTALLATION.

- a. Installation Method. Unless otherwise specified, outdoor cables running from one structure or item of equipment to another, shall be direct earth buried. Direct-earth burial cables shall be installed either by the trench and backfill method or by the cable plowing method in accordance with all the requirements specified herein.
- b. General Requirements.
 - (1) Underground cables shall be installed in straight lines between terminating locations or points of directional change.
 - (2) Unless otherwise specified, cables shall be installed a minimum of 24 inches and 30 inches below finished grade on airport property and off airport lands, respectively.
 - (3) Wherever possible, cable shall be installed in one continuous length without splices from connection to connection. The number of splices shall be kept to a minimum. Cable ends shall be effectively sealed against moisture immediately after cutting any type of cable. See the MALSR splice restrictions of Paragraph 13A.6.
 - (4) The contractor shall prepare a schedule for installing each reel of underground cable and shall submit it to the Resident Engineer for approval before installing any cable. The plan shall be predicated on use of the longest practical lengths of cable, in order to minimize splicing.
 - (5) A cable loop of at least three feet shall be left on each end of every cable run, on at least one side of every splice, and at all points where cable is brought above ground. A 3-foot minimum surplus cable length shall be left on both sides of splices in handholes and light bases. The slack loop shall be installed with the same minimum depth requirements as the cable run. Where cable is brought above ground, enough additional slack cable shall be left to make the required connections.

c. Trench and Backfill Installation Method.

- (1) Comply with all trenching, backfilling, compaction, and restoration requirements in Division 2.
- (2) The contractor shall unreel the cable adjacent to or over the trench and manually place it in the trench. Do not pull the cable into the trench or drag it along the trench.
- (3) Where more than one cable is installed in the same trench, maintain separation as hereinafter specified. Multiple cables shall be installed in the same relative positions throughout the cable trench. Cables shall not be stacked, crossed or intertwined in any manner.

d. Cable Plowing Method.

- (1) Vibratory cable plowing equipment, adequate for installation of the types of cables to be installed and for the depth required, may be used, provided that soil conditions are suitable, equipment is in good working order, and proper installation procedures are utilized.
- (2) While cable is being plowed into place, one person in addition to the operator of the plowing vehicle shall be present to assure that the cables do not kink or bind tightly while entering the plow.
- (3) If, during plowing operations, it appears that the soil contains sharp objects, rocks over 2 inches in diameter, or any other hazard to the cable, plowing shall be discontinued, and the Resident Engineer notified. The Resident Engineer shall determine whether plowing will be allowed to continue, or whether another cable placement method shall be used.
- (4) The slice left by the plow shall be closed by tamping or other approved method, after cable placement, to minimize the disturbance of the surface by the slice.

e. Cable Separation - Direct Burial.

- (1) Where new buried power cables cross over or under control or telephone cables, power cables shall be installed in a length of PVC duct extending two feet each side of the crossing. Minimum separation shall be twelve inches.
- (2) Power cables of the same circuit may be laid together in the trench without separation, except as noted below. Series lighting cables may be considered being of the same circuit.

16F.3e(3)

- (3) Power cables, of the same or different circuits of less than 600 volts, may be laid together in the same trench without separation.
 - (4) All power cables, 5,000 volts and below, shall be separated from all control, telephone and coaxial type cables by a minimum of 6 inches.
 - (5) Power cable, of more than 5,000 volts, shall be separated from all other cables by a minimum of 12 inches.
 - (6) Control, telephone, and coaxial cables may be laid in the trench without separation from each other.
- f. Buried Ground Wire (Counterpoise). Unless specified otherwise, all direct-earth burial power, control and coaxial cables shall include the installation of #6 bare copper ground wire (counterpoise) per Paragraph 16A.4e above.
- g. Cable Markers.
- (1) Cable runs shall be marked by concrete cable markers according to project drawings. Cable markers for underground cable shall be installed at all changes of direction in cable runs, at 300 feet intervals in straight-line cable run segments, and at all splice locations.
 - (2) Markers shall not be poured in place. The markers shall be installed flat in the ground immediately above the cable and with approximately one inch projecting above the surface. Impress additional circuit identification symbols on markers if so directed by the Resident Engineer. Existing cable markers removed or displaced shall be replaced after installation of new cable.

16F.4 CABLE INSTALLATION IN UNDERGROUND DUCTS AND CONDUIT.

a. Precautions.

- (1) Because almost all cable failures are caused by mechanical damage occurring during installation, the contractor should employ workmen experienced in underground cable installation, and utilize all the proper and unique equipment necessary for successful cable installation. Excessive direct tension, excessive sidewall pressure, sidewall impact, abrasion, sharp bending, and moisture intrusion will either destroy or shorten the useful life of cables installed.

16F.4a(2)

- (2) The following conditions and installation procedures, capable of damaging cable, shall be avoided:
 - (a) Sediment in ducts.
 - (b) Scoring of duct bends by pulling ropes.
 - (c) Inadequate support of guiding pulleys and pull tubes, resulting in binding of mechanisms and misalignment.
 - (d) Inadequate cable and duct lubrication, especially at bends.
 - (e) Dragging cables over manhole frame edges, duct entrances, and ground or pavement surfaces.
 - (f) Exposure to pedestrian or vehicular traffic.
 - (g) Looping in and out of manholes to avoid splicing.
 - (h) Power pulling at locations other than at ends of cable.
 - (i) "Jerking" of cables caused by too weak rope that elongates under tension, exerts momentary sharp pull on cable, recovers, and elongates for another like cycle.
 - (j) Sheaves and pulleys that stop rolling during pull, due to inadequate support or lubrication.
 - (k) Inadequate sealing and mechanical protection of cable ends.
 - (l) Reel surface and edge damage from poor hoisting techniques.
 - (m) Pulling distances too great.
- b. Installation Equipment. Major equipment items, required for installing cable in underground ducts, shall include the following:
 - (1) Power winch.
 - (2) Cable feed-in tubing guide capable of producing a uniform and rigid 3 and 4-foot and greater radius bend, and having a nominal diameter equal to that of the ducts.
 - (3) Single pulleys or sheaves providing a minimum cable bending radius (not overall sheave radius) of 10 times the largest cable diameter. Such sheaves shall be

16F.4b(3)

used for minor cable bends within "through cable" manholes and at feed-in manhole rims (if necessary). Sheaves shall have ball or roller bearings.

- (4) Adjustable gang pulleys with three or more pulleys capable of producing up to a 4-foot smooth cable bending radius. Each pulley shall have minimum cable bending radius of 10 times the largest cable diameter.
- (5) Lubrication equipment to pre-lubricate ducts, cables at guide-in tubing, and cables at intermediate pull-through manholes.
- (6) Cable reel support equipment including stands, arbor, and braking mechanism.
- (7) Dynamometer for measuring pulling tensions.
- (8) Communications equipment.
- (9) Pulling ropes or cords having the following characteristics:
 - (a) A working strength at least equal to the maximum allowable cable tensions as specified herein. "Working strength" is normally 10 to 14 percent of published rope "breaking strength".
 - (b) Rope or cord shall be a twisted or braided synthetic fiber unaffected by water and having a low level of elongation under load. Material shall have a texture non-injurious to plastic duct when pulled against bends. Wire rope, if proposed, shall have a smooth and rigidly adhering synthetic material covering.
 - (c) All pulling ropes or cords shall have swivel devices at cable attachment ends.
- (10) Cable lubricant specifically manufactured for electrical and control (telephone) cables. Do not use soap lubricants or those containing soap which are harmful to polyethylene- sheathed cables.
- (11) Cable pulling devices (secured to ends of cable as specified below).

c. Cable Pulling Devices.

- (1) Pulling devices for securing cable to pulling rope shall be factory-installed pulling eyes, field-installed pulling eyes, or basket weave cable grips. All shall be provided with integral or separate swivels.
- (2) Factory-installed pulling eyes necessitate that each cable pulling segment be cut to length by the cable manufacturer. Greater tensions and longer pulling lengths can be used with factory pulling eyes for straight duct bank segments.
- (3) Field-installed pulling eyes for control cable shall be a 4-crimp series, sized to the cable. Power cable pulling eyes shall be a type secured to conductors and approved by the Resident Engineer.
- (4) Basket weave cable pulling grips shall be carefully sized to the specific diameters of the cables to be installed. Use grips with a rotating eye feature for power and control (telephone) cables.

d. Duct Cleanout and Pre-Lubrication.

- (1) If any new or existing underground duct or conduit displays any evidence of contamination by soil or other foreign matter, such ducts or conduit shall be cleaned with a stiff bristle brush, swabbed, and flushed clean with water under pressure, before proceeding with cable pulling operations. Even a minor amount of soil or sediment in the bottom area of a duct will greatly increase the coefficient of friction and pulling tension required. With soil contamination, cable lubricant is of little value. Therefore, it is of utmost importance that conduit be cleaned prior to installation of cable.
- (2) It is the contractor's responsibility to determine whether ducts designated for occupancy should be cleaned. The contractor shall assume complete responsibility for any difficulties or damage to the cable in placing cable in ducts.
- (3) In addition to cable lubrication as specified elsewhere, all ducts to receive cables under this contract, shall be pre-lubricated using the same lubricant as for cables. Lubrication shall be thoroughly applied with applicators designed for this purpose. Lubrication on cable only, will rub off to a large degree, especially at duct bank offsets at manholes.

e. Setting Up Cable Reels and Apparatus.

- (1) The contractor shall inspect cable reels for flange protrusions which could damage the cable sheath. Also, the contractor shall inspect for any obstructions that could interfere with proper unwinding of the cable.
- (2) Careful control shall be exercised in the movement of cable reels. Where it is necessary to roll a reel to a desired location, it shall be rolled in the direction indicated by the arrows painted on the reel flanges. The reel shall not be allowed to tilt. A substantial runway of heavy planks should be employed where uneven ground conditions exist that may cause the reel to tilt. Where it is necessary to move a reel of cable with heavy equipment, a cable reel sling or equivalent should be used.
- (3) In conduit sections containing curves, the cable reel shall be set up at the manhole near the curve unless other conditions do not permit.
- (4) Cable reels shall be set up on the same side of the manhole as the conduit section in which the cable is to be placed. The reel shall be made level and brought into proper alignment with the conduit section so that the cable may be passed from the top of the reel in a long smooth bend at maximum radius into the duct without twisting and making more than a 90-degree bend. This is of utmost importance in handling filled type cable in temperature ranges of 35°F and lower. Under no circumstances shall the cable be pulled from the bottom of a reel.
- (5) It is essential that the cable reel be in proper alignment and level during the placing operation. Incorrect location of the reel will cause unnecessary binding which will result in uneven cable feed.
- (6) Do not permit adjacent turns of cable on the reel to stick together and cause binding as the cable is payed off the reel. Feed the cable by rotating the reel manually.
- (7) Other cable support equipment, such as pulleys, sheaves, and gang-pulley equipment shall be set up rigidly within intermediate manholes to smoothly guide cables to exiting ducts.

- f. Attaching Pulling Grips. All pulling grips shall be stretched onto the cables such that the entire lengths of the grip woven material will exert tension on the cable, thereby distributing stress. If the end of any cable grip

(furthest from the cable end) does not grip as tightly as the lead end, secure same to cable with a steel banding. Inspect cable grips frequently, and the first pull of control (telephone) cable in particular (in the first intermediate manhole), to ascertain that this requirement is fulfilled. If any uneven gripping is evident, banding will be required for all remaining cable installation of the applicable cable type and size.

g. Feeding and Pulling Cable.

- (1) All cable shall be installed using methods that will prevent excessive and harmful stretching, twisting, and flexing of the cable. Such damaging treatment will mechanically weaken the cable and destroy the electrical properties immediately or in a short time.
- (2) Cable may be pulled by hand or power winch. Pull rope shall be attached to cables with pulling eye or basket weave pulling grips (all equipped with swivels) for each cable pulled. Do not exceed maximum allowable pulling tension as hereinafter specified. Do not use cable manufacturer's maximum pulling tensions except for cable factory-installed pulling eyes.
- (3) All splices shall occur in manholes only. Splices shall not be pulled into ducts or manholes.
- (4) Cable feed-in tubing guide, same size as conduit, of suitable length shall be secured in the manhole between the cable reel and the face of the duct to protect the cable and guide it at the maximum possible smooth radius into the duct as it is payed off the reel.
- (5) A cable lubricator (funnel) shall be placed around the cable just ahead of the cable feed-in guide to facilitate lubrication of the cable. The quantity of lubricant shall conform to the lubricant manufacturer's recommendations.
- (6) Before starting to pull, check the equipment carefully to make sure that it is properly set up in order to minimize the chance of interruption once pulling has started. Tension shall be kept on both the cable reel and the pulling line at the start of the pull. Excessive slack and the twist of the pulling line may cause the connecting links to turn and catch in the duct. As far as possible, the cable shall be pulled in without stopping. A pulling speed of 80 to 100 feet per minute is recommended to minimize friction forces.

- (7) A person experienced with cable handling shall be posted continuously at the cable reel while pulling cable. In addition to braking the reels and observing cable lubrication, he shall carefully inspect cable paying off the reel for cable sheath and other defects. If defects are noticed, the pulling operation shall be stopped immediately and the Resident Engineer promptly notified of the defect. Kinks and/or irregularities in the cable sheath shall be removed or corrected as directed by the Resident Engineer.
- (8) Careful attention shall be paid to signals from the installation crew as the cable is being pulled so that pulling may be stopped instantly whenever necessary to avoid damage to the cable.
- (9) If for any reason the pulling operation is halted between manholes, the winch operator shall not release the tension on the winch unless directed to do so. In restarting the pulling operation, the inertia of the cable shall be overcome by gradually increasing the tension in steps a few seconds apart until the cable once again is in motion.
- (10) The leading end of the cable at intermediate manholes shall be guided into the duct and a feeder tube nozzle placed around the cable to prevent the cable from rubbing on the edge of the duct.
- (11) All pulled ends shall be examined for evidence of damage due to the pulling operation. The cable sheath shall not be pulled beyond the cable core. Notify the Resident Engineer for inspection, and for repair or replacement action that must be taken where cracks or openings are found in the cable sheath following the pulling operations.
- (12) Cable ends shall be kept sealed at all times using REA-approved cable end caps and electrical tape. After the cable has been placed, the exposed cable in the manholes should be wiped clean of cable lubricant with a cloth before leaving the manhole.
- (13) All individual cable segments shall be pulled in one direction only. Both ends of a cut cable segment shall not be introduced into an intermediate manhole and pulled in two different directions. Also, no cable segments shall be pulled out of any manhole and introduced into the same manhole for a continuation of a cable segment pull. These unacceptable pulling practices, used to avoid splicing, result in abrasion from dragging over ground surfaces and manhole frame, exposure to pedestrian and vehicular traffic,

damage to cable layers from twisting and small bending radii when pulling cable loops through manhole frame. Shields of cables so pulled are almost always damaged.

- (14) Sidewall cable pressure from duct bends, feed-in tubes, and pulleys, frequently govern the length of cable that can be pulled. The greater the radii, the less the sidewall pressure. Therefore, the contractor shall use the maximum radius at every manhole where a 90-degree pull is permitted. Adjustable gang pulleys with three or more pulleys shall be used for horizontal bends in manholes. Individual pulleys within the gang pulley device shall have a cable bending radius of minimum 10 times outside diameter of largest cable to be pulled. Width of pulleys shall be adequate to support the cable group to be pulled. Adjust gang pulleys to produce a smooth 90 degree curvature bend where such changes in direction occur.
 - (15) If cables will be spliced in a manhole where duct banks enter and leave 90 degrees apart, separate cable segments shall be introduced into the manhole and pulled in different directions unless pulling is permitted around a horizontal gang pulley within the manhole.
 - (16) Where more than one cable will be installed in a single duct, all shall be pulled into the duct concurrently.
- h. Cable Spoil. All cable pulling ends shall be trimmed back to remove cable material always damaged by pulling eyes or basket weave pulling grips. To remove such spoil, cut each cable off a distance from the end equal to three times the length of pulling eye or twice the length of the basket weave pulling grip as a minimum. These amounts shall be cut off for all cables including those to be spliced or terminated by others.
- i. Use of Dynamometer.
- (1) The dynamometer shall be accurately calibrated and secured to properly indicate tension exerted on the cable. The dynamometer reading will usually give the resultant force exerted on the anchoring device, which shall be converted to the horizontal component to give correct value of pulling tension.
 - (2) Dynamometer readings shall be made only in the presence of the Resident Engineer. If any pulling tension is approaching the maximum allowable, and if in the judgment of the Resident Engineer, the allowable will be appreciably exceeded for the proposed run, pulling

16F.4i(2)

operations shall be immediately stopped, and the cable run spliced in the preceding manhole.

- j. Maximum Cable Pulling Tensions. Maximum allowable cable pulling tensions, as measured by dynamometer, shall not exceed the following values for single cables. For multiple cables, add the tension values for the number of cables being pulled. Use a pulling rope having a working strength [not breaking strength -- reference subsection 16F.4b(9)] at least equal to the "maximum allowable pulling tension" values below.

<u>Cable</u>	<u>Maximum Allowable Pulling Tension (lbs)</u>
1-1/C #8	125
1-1/C #6	200
1-1/C #4	325
1/1-C #2	500
1-6 PR #19	125
1-12 PR #19	250
1-25 PR #19	500

- k. Separation of Cables Installed in Conduit or Duct.
- (1) Power cables of the same voltage may be installed in the same duct.
 - (2) Power cables of less than 600 volts may be installed in the same duct.
 - (3) Power cables of less than 600 volts shall not be installed in the same duct with control, telephone, or coaxial type cables.
 - (4) Power cables of more than 600 volts shall not be installed in the same duct with control, telephone, coaxial, or power cables of less than 600 volts.
 - (5) Control, telephone, and coaxial cables may be installed in the same duct.
- l. Cable Installation in Manholes or Handholes.
- (1) Power and control cables shall be installed in separate manholes or handholes unless otherwise specified. If installed in same manhole, install power and control cables on opposite sides. At splice locations, use cable racks at different elevations to separate power and control cables.

16F.41(2)

- (2) Cable racking surplus shall be pulled back by hand into intermediate manholes. Pull surplus one manhole at a time beginning near both ends of cable segment. Do not use power winch unless permitted by the Resident Engineer.
- (3) Cables shall be carefully routed around manhole interiors, taking all necessary precautions to prevent sharp bending. Cable racks shall be plastic or galvanized steel with properly sized porcelain insulators for the latter. Fasten all cables to plastic racks with nylon ties and to steel racks by means of the insulators.
- (4) Where a splice occurs, cable shall make one loop around the manhole, and the splice located near the center of the loop.
- (5) Where power and control cables are installed in the same manhole, the entire exposed length of all power and control (telephone) cables shall be fireproofed by applying fire and arc proofing tape per Paragraph 16A.23 above.

16F.5 CABLE TAGGING.

- a. All cables shall be tagged in each manhole and in each terminal cabinet with not less than two tags per cable, one near each duct entrance hole. Tags shall be attached to cables immediately after installation of each cable.
- b. Tags shall be circular in shape and 2 inches in diameter. Material shall be minimum 0.020-inch thick copper or brass or 0.0625-inch thick lead. 1/4-inch high steel lettering dies or equivalent size engraving equipment shall be used to make the tags. Tags shall be secured firmly to cables with Number 14 AWG copper wire.
- c. Tag markings shall consist of an abbreviation of the facility served by the cable and the letter "P" or "C" denoting power or control. The facility shall include the applicable runway. Where like multiple control cables are routed between the same facilities, further identify such cables throughout the run with a single-digit number following the letter "C". All individual-conductor power circuits shall be bundled under the same tag as opposed to separate tags for each conductor.

16F.6 SPLICING.

a. General Requirements.

- (1) Splices shall be performed only by experienced and qualified cable splicers regularly engaged in this type of work.

16F.6a(2)

- (2) Cable armor and/or shielding shall be bonded together across splices to provide continuous electrical paths.
 - (3) Where a cable is cut preparatory to splicing, the work shall proceed without delay. When an unavoidable delay is encountered in completing a splice, the opened cable shall be protected to prevent the entrance of moisture and foreign matter.
 - (4) Any splicing material (such as resin) older than the do-not-use-after date on the package, shall be replaced with new material at the contractor's expense.
 - (5) Unless otherwise specified, where multiple runs of single-conductor underground power cables are spliced, each single-conductor cable shall be spliced in a separate envelope.
 - (6) Approved stress reduction methods shall be used in splicing all shielded high voltage power cables (5KV and higher voltage).
- b. Underground Power Cable Splices (600 Volts or Less). All low voltage splices shall be encapsulated in pressure resin in clear plastic envelopes, except as otherwise specified in Paragraph 13A.6 above, on drawings, or in special specifications. All low voltage splices shall be made with compression connectors specified in Paragraph 13A.6 above, except as otherwise specified on drawings and in special specifications.
- c. Underground Control (Telephone Cable) Splices.
- (1) Kit and Resin. The splices shall consist of a rigid polypropylene mold body with a built-in spacer web to provide cable centering and proper compound coverage. The mold body shall be filled with a flexible polyurethane electrical compound capable of continuous operation at 90°C, with an emergency overload temperature rating of 130°C. Splices must have provisions for inline splicing of shielded or non-shielded plastic or rubber-jacketed control (telephone) cables. The splices shall be rated for direct burial applications. For control cables with outside diameters between 0.25 inches and 3.25 inches, 3M Scotchcast Signal and Control Cable Inline Splicing kits of the 72N series are approved, as they are among kits which meet specifications.
 - (2) Connectors. Control cable splice connectors shall be in-line type, in which two conductors are spliced by laying one conductor in each end of the connector, and crimping the connector with a special tool selected to match the connector type and size. Before crimping,

16F.6c(2)

the connector is open on one side of its length. After crimping, the connector is closed all around its length. The connector bodies shall be made with a tin-plated phosphor bronze piece on the inside, to contact the cable conductors, and bonded polyester insulation on the outside, to insulate the connection. The insulation shall be color coded to denote wire size range. The cable splice connectors and tools shall incorporate the insulation displacement termination technique which uses a slotted, tin-plated contact to displace the conductor insulation, thus providing four redundant electrical contact points. Connectors which require prestripping the conductor shall not be used. AMP, Inc. (Harrisburg, PA) Picabond connectors sized for conductor size, and matching AMP tooling, are among products meeting the above specifications, and are approved.

- d. Submittals. See Paragraph 1A.4 above. If the contractor --
- (1) Intends to splice using materials different from those specified in Paragraphs b and c above, or
 - (2) Intends to splice a 5KV or higher voltage power cable,
- then the contractor shall submit to the Contracting Officer, shop drawings or catalog cuts for all splicing materials, tools, and dies. The contractor shall splice no cables before he has received the Contracting Officer's approval of these items.

16F.7 CONTROL (TELEPHONE) CABLE TERMINATIONS.

a. Cable Routing and Support.

- (1) Cable jackets shall be removed within terminating enclosures such that no more than 2 inches of jacket material is visible within the enclosures. Ground shielding and armor as specified below.
- (2) Exposed cable conductor bundles shall be lock-stitched laced together with nylon lacing twine spaced at approximate 5/8- inch intervals. Each bundle shall contain maximum 25 pairs of conductors which shall be neatly routed and secured to backing panels with nylon clamps.

b. Cable Pair Terminations.

- (1) Terminated pairs shall have the same sequence on each terminal strip. (For terminal block specifications, see Paragraph 16A.19, above.) The color code termination sequence on the terminal strips shall be in accordance with the following schedule. The white

16F.7b(1)

mates shall start at the top or left-hand side of the terminal block with color continuing down or across the block according to the following schedule:

<u>MATE COLORS</u>	<u>PRIMARY WIRE COLORS</u>
WHITE	BLUE
"	ORANGE
"	GREEN
"	BROWN
"	SLATE
RED	BLUE
"	ORANGE
"	GREEN
"	BROWN
"	SLATE
BLACK	BLUE
"	ORANGE
"	GREEN
"	BROWN
"	SLATE
YELLOW	BLUE
"	ORANGE
"	GREEN
"	BROWN
"	SLATE
VIOLET	BLUE
"	ORANGE
"	GREEN
"	BROWN
"	SLATE

- (2) When cables do not have the preceding color code, like pairs shall be terminated in the same sequence at both ends of the cable.

16F.8 CABLE ARMOR AND SHIELD GROUNDING.

a. Grounding Locations.

- (1) Control cable armor and/or shielding shall be grounded at one end of each cable run only.
- (2) Power cable armor shall be grounded at both ends of each cable run.
- (3) Shielding and armor of control and power cables shall not be grounded at splice locations.

16F.8b

b. Grounding Procedures.

- (1) Use #14 AWG stranded copper grounding conductors for grounding shielding and armor. Secure grounding conductors to shielding and armor by using UL-approved grounding connectors specifically designed for this purpose. Neatly tape ends of butted cable to conceal the connections.
- (2) Attach crimp-type lugs of proper size to free ends of grounding conductors, and secure lugs to enclosure interior wall with a machine screw and nut.

16F.9 CABLE TESTING.

a. General Requirements.

- (1) Both before and after installation, all contractor-furnished and Government-furnished power and control (telephone) cables shall be tested as required herein. Testing after installation shall be accomplished across splices.
- (2) All testing shall be accomplished in the presence of the Resident Engineer. Furnish two signed and dated copies of all test results, clearly tabulated for all segments of cable tested, to the Resident Engineer.
- (3) The contractor shall use his own test equipment, which shall bear current calibration certification from a certified instrument calibration laboratory.
- (4) Any measured values not conforming to specified values shall be cause for rejection of the defective cable installation. After repair or replacement, if so required by the Resident Engineer, cable shall be retested and additional remedial work performed until satisfactory test results are obtained. All repair and replacement work shall be accomplished at no additional cost to the Government.

b. 600-Volt Power Cable Testing.

- (1) Conductor continuity shall test positive.
- (2) Armor continuity shall test positive.
- (3) Dielectric strength/insulation resistance shall test 50 megohms minimum at 500 volts D.C. between the following:
 - (a) Conductor and ground for single-conductor cable.

16F.9b(3)(b)

(b) Individual conductors for multi-conductor armored cable.

(c) Individual conductors and grounded armor.

c. Control (Telephone) Cable Testing.

(1) Conductor continuity shall test positive.

(2) Shield continuity shall test positive.

(3) Armor continuity shall test positive.

(4) Dielectric strength/insulation resistance shall test 50 megohms minimum at 500 volts D.C. between paired conductors and between individual conductors and grounded shield.

(5) After installing control cable, the minimum number of acceptable paired conductors shall comply with the following:

(a) For 11 pair or less cable, all pairs shall test acceptable.

(b) For 12 to 25 pair cable, all pairs except one shall test acceptable.

SPECIFICATIONS SUPPLEMENTAL TO
SPECIFICATIONS FAA-GL-840b AND FAA-GL-918C

10/28/03

1. Contractor-Furnished Frangible Couplings. The following specifications supersede Paragraph 16A.20 of Specification FAA-GL-918C. The Contractor shall furnish all the frangible couplings to be applied under this contract. All frangible couplings shall be 2"-diameter cast aluminum couplings having hexagonal clamping ring. The coupling shall accommodate 2"-diameter EMT conduit. The frangible couplings shall meet the requirements of either Military Specification MS-17814-1, or of FAA Drawing C-6046. The straight-thread Multi-Electric Cat. No. 961-A frangible coupling is among couplings meeting MS-17814-1. The tapered-thread Multi-Electric Cat. No. 961-AT frangible coupling is among couplings conforming to FAA Drawing C-6046. If the Contractor intends to furnish substitute frangible couplings, the Contractor shall submit to the Contracting Officer, catalog cuts demonstrating that the substitute couplings meet the above specifications. The Contractor shall furnish at least 110 each of the frangible couplings. The Contractor shall turn all spare frangible couplings over to the Resident Engineer, who will deliver them to FAA maintenance personnel.
2. MALS PAR-38 Lamps.
 - A. Specifications. The following specifications override Paragraph 13A.5. The Contractor shall furnish fifty-five PAR-38 halogen incandescent spot lamps. The lamps shall be rated by the manufacturer to have 120-watt power, approximately 1900 lumens and 25000 center beam candlepower (CBCP), and 3000 hours average lamp life at 120 volts. Sylvania lamps of lamp designation 120PAR/CAP/SPL/SP and NAED (Vendor I.D. No.) code 14856 meet these specifications. If the Contractor intends to furnish lamps other than Sylvania No. 14856, the Contractor shall submit to the Contracting Officer the substitute lamp's candlepower distribution curve and manufacturer's technical data sheets demonstrating that the substitute meets the power, brightness, and lamp life and lumen maintenance criteria of the above specifications. The contractor shall also furnish a sample lamp, and shall demonstrate that it will fit the lamp aiming device supplied with the MALSR.
 - B. Application. The Contractor shall install 45 of these lamps on the 5-light bar structures. The remaining 10 lamps shall be delivered to the Resident Engineer for use as spares. The installed lamps shall be aimed vertically to the aiming angles specified on the drawings.
3. CONTROL CABLE SHIELD GROUNDING. Control cable shield shall be grounded at each end of each cable run. This requirement overrides Specification FAA-GL-918C, Paragraph 16F.8a(1) and Specification FAA-GL-840B, Paragraph 16F.8a(1).

4. SUPPLEMENTAL LIGHTNING ARRESTER. If lightning arresters are not furnished with the MALSR equipment, or supplemental lightning arresters are required, the lightning arresters shall meet the following specifications:

- A. Voltage rating: 120/240 VAC, 3 wire, 1 phase, 50/60Hz.
Each L (black wire) to N (neutral wire) 120 VAC.
L (black wire) to L (black wire) 240VAC.
- B. Conduction starts @ 240V peak.
- C. Operation: Bipolar, same performance on either polarity of surge.
- D. Power consumption: None
- E. Power follow current: None
- F. Load or source KVA: Unlimited.
- G. Temperature range: -50^oC to +80^oC.
- H. Response: Less than one nanosecond.
- I. Extreme lightning and surge duty: 55 KVA each line to ground.
- J. Discharge voltage vs. surge current, each line to ground:

@	1.5 KA, 8x20us	420V peak
	5.0	520
	10.0	550
	20.0	700
	30.0	825
	50.0	970

K. Life, each line to ground:

@	1.5KA, 8x20us	60,000 operations
	5.0	3,000
	10.0	300
	20.0	50
	30.0	15
	50.0	5

Lightning and electrical surge arrester Model LPC 10262-6 from Lightning Protection Corporation (Goleta, CA) meets the above specifications.

5. Fluorescent Light Fixtures and Ballasts. The following specifications supersede Paragraph 16A.17f of Specification FAA-GL-918C.

- f. Interior Light Fixture and Lamps. Each interior light fixture shall be a surface-mounted, 120-volt, fluorescent light fixture having a high-gloss white painted steel chassis and a light-controlling acrylic lens enclosure. The lens (diffuser, refractor) enclosure shall be of a wraparound style that illuminates the ceiling as well as the room. The enclosure shall be hinged on one side, or shall pull down, for cleaning and maintenance. The fixture shall be nominally four feet long, and shall accommodate two 48"-long T-8 fluorescent lamp tubes. The ballast shall have a radio frequency suppressor. The ballast shall operate normally at temperatures above 20°F. The lamp tubes shall be 32-watt 48"-long T-8 fluorescent lamp tubes, each with an initial rating of 2,850 lumens. The following 32-watt lamp tubes are among lamps which meet these specifications:

General Electric Trimline, Philips TL70, and Sylvania Octron. The following light fixtures are among fixtures that meet the above specifications.

- (1) Day-Brite Cat. No. HWN232-120-1/2-EB, with:
 - (a) Valmont Electric Cat. No. E232-P1 120 G01 two-lamp electronic ballast, rated at zero degrees F., and
 - (b) Valmont Electric Cat. No. 89G635RFI filter.
- (2) Holophane Model No. HW-S-M-4-D-S-H71-042-LP-1-1 with RF suppressor
- (3) Lithonia Model No. WA-2-32-120-GEB-RIF1
- (4) Metalux Cat. No. W-232A-120-LEOC8-RIF1

If the contractor desires to furnish and install other light fixtures than those listed above, or a tandem connected and wired version of the 4'-long fixture listed above, the contractor shall submit catalog cuts of the fixture, and receive the Contracting Officer's approval before procuring.

6. NO ASBESTOS. No material containing asbestos shall be installed under this contract.
7. GROUNDING ELECTRODE. The following specifications supersede Paragraph 16A.4c of Specification FAA-GL-918C.
 - c. Grounding Electrode. Grounding electrodes (rods) shall be copper clad steel, 3/4-inch by 10 feet, except where otherwise specified. The top of the grounding electrode shall be a minimum of 12 inches below finished grade. Conductors shall be attached to electrodes with exothermic welds only, except where fire or explosion hazards exist, as near existing fuel tanks. Where such hazards exist, hydraulically crimped connections will be permitted as specified below.
8. ELECTRODE GROUND TESTING. The following specifications supersede Paragraph 16A.4h of Specification FAA-GL-918C.
 - h. Testing. Electrode grounds shall be tested for resistance at each location. Resistance to ground for each grounding location shall be 10 ohms or less. If this value is not achieved with the grounding electrodes as shown on the drawings, additional grounding electrodes spaced at least 6 feet apart, or electrode extensions of the same construction and diameter, shall be installed until the resistance value does not exceed the maximum of 10 ohms. A tabulated report of the final resistance value at each location shall be provided to the Resident Engineer.
9. AIR TERMINAL BRACE. The following specifications supersede Paragraph 16A.18c of Specification FAA-GL-918C.
 - c. Air Terminal Brace Assembly. The air terminal brace assembly for a 36" air terminal shall be a 24"-long galvanized tripod assembly, with legs

adjustable to accommodate any roof slope. Cat. No. 82 meets these specifications.

10. GROUND ROD CLAMPS. Paragraph 16A.18k, Ground Rod Clamps, of Specification FAA-GL-918C, is deleted.
11. CONTROL CABLE. The following specifications supplement Paragraph 16E of Specification FAA-GL-918C.

Specification. Control cable shall be either:

- REA Specification PE-39 cable meeting all the requirements of Section 16E, or
- REA Specification PE-89 cable (having foamed polyethylene or propylene conductor insulation with a solid skin of the same material), meeting all requirements of Specification FAA-GL-918C Section 16E except the REA Specification PE-39 requirements.

12. FACILITY AC SURGE ARRESTER.

The following paragraph supersedes Paragraph 16A.16d of Specification FAA-GL-918C.

d. Arrester Meeting Specifications. For 120/240V, single phase, 60Hz applications, the Lightning Protection Corporation (Goleta, California) Model No. LPC 20206-7 AC surge arrester is one of the products that meet the above specifications. This arrester must be equipped with two Class J fuses, 60 amp, time-delay, 200KAIC (interrupting capacity), UL listed. If the contractor intends to furnish a substitute, or if a different power configuration must be accommodated, the contractor shall submit to the Contracting Officer, full manufacturer's literature on the substitute arrester, and shall not procure the substitute before receiving the Contracting Officer's approval. See Paragraph 1A.4 above.

The following paragraph is added to Paragraph 16A.16e of Specification FAA-GL-918C.

(4) Fuses. The surge arrester must be equipped with two Class J fuses, 60 amp, time-delay, 200KAIC (interrupting capacity), UL listed.

13. PAPI PLATE. The following paragraph supplements and supersedes Paragraph 13D.2 of Specification FAA-GL-918C.

13D.2 SCREW ANCHOR FOUNDATION DESIGN AND USAGE. On drawings, screw anchor foundations are also called screw-in foundations and screw-in-anchor foundations.

- a. Screw Anchor Foundations. The two most frequently used screw anchor foundations, are shown on Figures 1 and 2 at the end of this section. The Figure 1 foundation is commonly used for ILS, RVR, MALSR, and PAPI facilities. The Figure 2 foundation is commonly used for REIL facilities. A. B. Chance

foundations, Cat. Nos. T112-0262 and T112-0676, are among the products that meet the requirements of Figures 1 and 2, respectively. These items are also known by Cat. Nos. CT112-0262, CT112-0676. The Chance Figure 1 foundation is known as an "Instant" foundation (formerly known as a streetlight foundation).

- b. **PAPI Plate.** The PAPI plate of Figure 3 in Specification FAA-GL-918C does not describe the current A. B. Chance PAPI plate, Chance Cat. No. T112-0337 or CT112-0337. Figure 3 has a 26.65" dimension, and describes the old PAPI plate, which accommodated the AVW PAPI. The current (2002) PAPI plate, Chance Cat. No. T112-0337 or CT112-0337, has a 28" dimension in place of the 26.65" dimension. The current A.B. Chance PAPI plate is shown on A. B. Chance Drawing No. SA112-0337, Rev C dated 07-08-93, and accommodates the NBP PAPI, Type FA-10620, NSN 8200-00-600-82751.

14. **STEEL SIDING.** The following paragraph supplements and supersedes Paragraph 13E.8 of Specification FAA-GL-918C.

13E.8 **STEEL SIDING.** Furnish and install steel siding panels and accessories in accordance with manufacturer's instructions and the following material specifications.

- a. **Steel Sheet and Coating.** The siding is made from roll formed 0.0172 inch (nominal) thick hot-dipped galvanized steel complying with ASTM A653 and having minimum yield and ultimate strength of 33,000 and 55,000 psi respectively. The coating is polyvinyl chloride, 4 mils dry film thickness. Unless otherwise specified on the drawings, the outside finish color is white.
- b. **Siding Meeting Specifications.** Coated steel siding by Rollex Corporation, Elk Grove Village, Illinois is among products meeting these specifications. Substitutes require submittals per Paragraph 1A.4 above.

15. **BURIED GUARD WIRE.**

The following paragraph supplements and supersedes Paragraph 16A.4e of Specification FAA-GL-918C.

- e. **Buried Guard Wire.** Buried cables (including armored cables) not completely enclosed in ferrous conduit, shall be protected by a bare copper guard wire. Unless specified otherwise, or shown otherwise on the drawings, the guard wire shall be #1/0 AWG. Embed the guard wire in the soil at least 10 inches directly above and parallel to the cables being protected. Where the width of the run of cables or ducts does not exceed 3 feet, install one guard wire centered over the cable or duct run. Where the cable or duct run is more than 3 feet wide,

install two guard wires. Space the two guard wires at least 12 inches apart, and 12 to 18 inches inside the outermost wires or outermost edges of the duct. Weld the guard wire exothermically to a grounding electrode at each end, and to grounding electrodes at approximately 90-foot intervals. The spacing between the grounding electrodes shall vary by 10 to 20 percent, to prevent resonance.

The following paragraph supplements and supersedes Paragraph 16F.3f of Specification FAA-GL-918C.

- f. Buried Guard Wire. Unless specified otherwise, all direct-earth burial power, control, and coaxial cables shall include the installation of #1/0 bare copper ground wire per Paragraph 16A.4e above.
16. PAR-38 LAMPHOLDER SOCKET RETENTION SCREWS. If DME Corp. MALSR equipment is furnished by either the FAA or the contractor, the contractor shall inspect the PAR-38 lampholders. It is probable that the heads of the socket retention screws furnished with the lampholders are too wide to fit into the socket recesses. If they are, the contractor shall furnish stainless steel 6-32 x 1 1/4" socket head cap screws to install the sockets in the lampholders. Two cap screws are required per PAR-38 lampholder.

FAA-STD-019e
December 22, 2005



DEPARTMENT OF TRANSPORTATION
FEDERAL AVIATION ADMINISTRATION STANDARD

LIGHTNING AND SURGE PROTECTION,
GROUNDING, BONDING AND SHIELDING
REQUIREMENTS FOR FACILITIES AND
ELECTRONIC EQUIPMENT

This Page Intentionally Left Blank

FOREWORD

All construction of Federal Aviation Administration (FAA) operational facilities and the electronic equipment installed therein shall conform to this standard. This document defines minimum requirements for all FAA facilities. When the specific needs of a facility exceed these minimum requirements, the facility shall be designed and installed to meet these specific needs. These needs are influenced by the equipment to be installed at the site, the configuration of the structures and location of the equipment, and by the physical environment present at the location.

The requirements contained in this document reflect investigation and resolution of malfunctions and failures experienced at field locations. The requirements thus are considered the minimum necessary to harden sites sufficiently for the FAA missions – to prevent delay or loss of service, to minimize or preclude outages, and to enhance personnel safety. Further, the requirements in the document have been coordinated with industry standards, and in some cases exceed industry standards where necessary to meet the FAA missions.

In this document the use of “shall” or verbs such as “construct”, “weld”, “connect”, etc indicates a requirement necessitating mandatory compliance. In cases when implementation of certain requirements is not technically feasible, a National Airspace System (NAS) Change Proposal (NCP) must be submitted with adequate justification and technical documentation and approved by the NAS Configuration Control Board (CCB) before a deviation is permitted.

This document is organized in accordance with MIL-STD-962D.

This Page Intentionally Left Blank

TABLE OF CONTENTS

1	SCOPE	1
1.1	Scope	1
1.2	Purpose	1
2	APPLICABLE DOCUMENTS	3
2.1	Government Documents	3
2.2	Non-Government Documents.....	4
3	DEFINITIONS	7
3.1	Access Well	7
3.2	Air Terminal	7
3.3	Armored Cable	7
3.4	Arrester.....	7
3.5	Bond	7
3.6	Bond, Direct.....	7
3.7	Bond, Indirect.....	7
3.8	Bonding.....	7
3.9	Bonding Jumper	7
3.10	Branch Circuit	7
3.11	Building.....	7
3.12	Bulkhead Plate.....	8
3.13	Cabinet	8
3.14	Cable	8
3.14.1	Cable, AC (not the same as armored (DEB) cable).....	8
3.14.2	Cable, Armored Direct Earth Burial (DEB).....	8
3.14.3	Cable, Axial	8
3.14.4	Cable, Shielded.....	8
3.15	Case	8
3.16	Catenary Wire	8
3.17	Chassis	8
3.18	Clamp Voltage	8
3.19	Conductor, Bare.....	8
3.20	Conductor, Insulated.....	9
3.21	Conductor, Lightning Bonding (Secondary).....	9
3.22	Conductor, Lightning Down.....	9
3.23	Conductor, Lightning Main	9
3.24	Conductor, Lightning Roof	9
3.25	Crowbar	9
3.26	Earth Electrode System (EES)	9
3.27	Electromagnetic Interference (EMI).....	9

3.28	Electronic Multipoint Ground System	9
3.29	Electronic Single Point Ground (SPG) System	9
3.30	Enclosed Ferrous Cable Tray	10
3.31	Equipment Areas	10
3.32	Equipment Grounding Conductor	10
3.33	Equipment	10
3.34	Facility Ground System	10
3.35	Faraday Cage	10
3.36	Feeder	10
3.37	Ferrous Conduit	10
3.38	Fitting, High Compression	10
3.39	Ground	10
3.40	Grounded Conductor	10
3.41	Grounded	11
3.42	Grounding Conductor	11
3.43	Grounding Electrode	11
3.44	Grounding Electrode Conductor	11
3.45	High frequency	11
3.46	Horizontal Transitions	11
3.47	Landline	11
3.48	Line Replaceable Unit	11
3.49	Low Frequency	11
3.50	Main Service Disconnect	11
3.51	National Electrical Code	12
3.52	Operational Areas	12
3.53	OPR	12
3.54	Overshoot Voltage	12
3.55	Pressure Connector	12
3.56	Rack	12
3.57	Reference Plane or Point, Electronic Signal (Signal Ground)	12
3.58	Rigid Metal Conduit (RMC)	12
3.59	RGS	12
3.60	Shield	12
3.61	Signal	12
3.62	Standard Version	13
3.63	Structure	13
3.64	Surge	13
3.65	Susceptibility Level	13
3.66	Transient	13
3.67	Transient Suppressor	13

3.68	Turn-on Voltage	13
3.69	Zone of Protection	13
4	GENERAL REQUIREMENTS	15
4.1	Requirements Common to Both Facilities and Equipment.....	15
4.1.1	Bonding Requirements	15
4.1.1.1	Resistance of Bonds	15
4.1.1.2	Methods of Bonding	15
4.1.1.2.1	Exothermic Welds	15
4.1.1.2.2	Welded Assemblies.....	15
4.1.1.2.3	Dissimilar Metals.....	16
4.1.1.2.4	Mechanical Connections	17
4.1.1.3	Bonding Straps and Jumpers	18
4.1.1.4	Fasteners	19
4.1.1.5	Temporary Bonds.....	19
4.1.1.6	Inaccessible Locations.....	19
4.1.1.7	Surface Preparation	19
4.1.1.7.1	Area to Be Cleaned.....	20
4.1.1.7.2	Final Cleaning	20
4.1.1.7.3	Completion of the Bond	20
4.1.1.7.4	Refinishing of Bond.....	20
4.1.1.7.5	Surface Plating or Treatments	20
4.1.1.8	Bond Protection	20
4.1.1.8.1	Paint	20
4.1.1.8.2	Compression Bonds in Protected Areas	21
4.1.1.8.3	Corrosion Protection.....	21
4.1.1.9	Bonding across Shock Mounts	21
4.1.1.10	Enclosure Bonding.....	21
4.1.1.11	Subassemblies	21
4.1.1.12	Equipment.....	21
4.1.1.13	Connector Mounting	21
4.1.1.14	Shield Terminations	22
4.1.1.15	RF Gaskets	22
4.1.2	Shielding Requirements.....	23
4.1.2.1	Design	23
4.1.2.2	Facility Shielding	23
4.1.2.3	Conductor and Cable Shielding	23
4.1.2.3.1	Signal Lines and Cables.....	23
4.1.2.3.2	Termination of Individual Shields	23
4.1.2.3.3	Termination of Overall Shields	24
4.1.2.4	Electromagnetic Environment Control	26
4.1.2.4.1	Space Separation	26
4.1.2.4.2	Wire and Cable Routing	26
4.1.2.4.3	Gaskets	27
4.1.2.4.4	Filter Integration	27
4.1.2.4.5	Bonding and Grounding of Compartment Shields.....	27
4.1.3	Electrostatic Discharge (ESD) Requirements.....	27
4.1.3.1	ESD Sensitivity Classification	28
4.1.3.2	ESD Protection Requirements	28
4.1.3.3	Classification of Materials	28
4.1.3.3.1	General.....	28
4.1.3.3.2	Conductive Materials.....	28
4.1.3.3.3	Electrostatic Shielding Materials	28
4.1.3.3.4	Electromagnetic Shielding Materials.....	29
4.1.3.3.5	Static Dissipative Materials	29

4.1.3.3.6	Antistatic Materials.....	29
4.1.3.3.7	Static-Generative Materials, Non-Conductors, and Insulators.....	29
4.1.3.4	Protection of ESD Susceptible and Sensitive Items.....	29
4.1.3.4.1	Static Protected Zone.....	29
4.1.3.4.2	ESD Special Protection Areas.....	30
4.1.3.4.3	ESD Controls Required for ESD Special Protection Areas.....	30
4.1.3.4.4	ESD Signs, Labels, Cautions, and Warnings.....	31
4.1.3.4.5	ESD Protected Workstations.....	31
4.1.3.4.6	ESD Protective Storage Areas.....	32
4.1.3.4.7	Hard and Soft Grounds.....	33
4.1.3.4.8	ESD Control Flooring and Floor Coverings.....	33
4.1.3.4.9	ESD Requirements for Raised Floors.....	34
4.1.3.4.10	ESD Protective Worksurfaces.....	35
4.1.3.4.11	Static Dissipative Coatings.....	36
4.1.4	Electromagnetic Compatibility Requirements.....	36
4.1.4.1	General.....	36
4.1.4.2	Requirements.....	36
4.1.4.3	Approval.....	36
4.2	Facility Requirements.....	36
4.2.1	Passive Transient Protection Requirements.....	36
4.2.1.1	Existing Metallic Conduit, Conductors and Cables.....	36
4.2.1.2	Electromagnetic Shielding for Lines, Conductors and Cables.....	37
4.2.1.2.1	Facility Entrance Conduit.....	37
4.2.1.2.2	Buried External Power Cables.....	37
4.2.1.2.3	Conduit Joints and Fittings.....	37
4.2.1.3	Above Ground Ferrous Conduit Penetration of Facility.....	38
4.2.1.4	Armored Direct Earth Burial (DEB) Cables.....	38
4.2.1.5	Guard Wires.....	38
4.2.1.6	Metal Bulkhead Connector Plates.....	38
4.2.1.7	Balanced Pair Lines.....	39
4.2.1.8	Fiber Optic Cable.....	39
4.2.1.9	Interior Lines, Conductors and Cables.....	39
4.2.2	Active Transient Protection Requirements.....	40
4.2.2.1	Conducted Power Line Surges.....	40
4.2.2.2	Facility Service Entrance Surge Protective Device.....	40
4.2.2.3	Surge Protective Devices for Feeder and Branch Panels.....	40
4.2.2.4	SPD General Requirements.....	41
4.2.2.4.1	SPD Operational Characteristics.....	41
4.2.2.4.2	Surge Levels.....	42
4.2.2.4.3	Slope Resistance.....	43
4.2.2.4.4	3kA Voltages V_3	43
4.2.2.4.5	Indicator Lamps.....	43
4.2.2.4.6	Accessibility.....	44
4.2.2.5	Signal, Control, and Data Line Protection Design.....	44
4.2.2.6	SPD Requirements for Signal Data and Control Lines.....	45
4.2.2.6.1	Signal, Control, and Data Line Protection Requirements.....	45
4.2.2.7	Axial Cable Protection Design.....	46
4.2.3	Lightning Protection System Requirements.....	46
4.2.3.1	General.....	46
4.2.3.2	Lightning Protection System Materials.....	47
4.2.3.2.1	Lightning Protection System Conductors.....	47
4.2.3.2.2	Lightning Protection System Hardware.....	47
4.2.3.2.3	Guards.....	47
4.2.3.3	Lightning Protection System Bonds.....	47
4.2.3.3.1	Metallic Bodies Subject to Direct Lightning Strikes.....	47

4.2.3.3.2	Metallic Bodies Subject to Induced Charges	48
4.2.3.3.3	Exhaust Stack Grounding.....	48
4.2.3.3.4	Above Ground Fuel and Oil Storage Tanks.....	48
4.2.3.3.5	Conductive Bodies Within a Zone of Protection.....	48
4.2.3.4	Conductor Routing.....	48
4.2.3.4.1	Down Conductors on Fiberglass Mounting Poles.....	49
4.2.3.4.2	Down Conductor Terminations	49
4.2.3.5	Lightning Protection for Buildings and Structures.....	49
4.2.3.5.1	Air Terminals	49
4.2.3.5.2	ATCT Potential Equalization.....	50
4.2.3.5.3	Number of Down Conductors for Buildings	50
4.2.3.5.4	Metal Parts of Buildings	50
4.2.3.5.5	Roof Mounted Antenna Masts	50
4.2.3.6	Lightning Protection for Antenna Towers	51
4.2.3.6.1	Number of Down Conductors for Towers.....	51
4.2.3.6.2	Towers without Radomes	51
4.2.3.6.3	Radomes.....	51
4.2.3.6.4	Towers with Radomes.....	52
4.2.3.6.5	Antenna Protection	53
4.2.3.6.6	Tower Guying.....	53
4.2.3.6.7	Waveguide, Axial Cable, and Conduit Grounding.....	53
4.2.3.6.8	Staircase/Ladder Protection.....	53
4.2.3.7	Lightning Protection for Facilities without Buildings or Antennas	54
4.2.3.8	Lightning Protection for Fences and Gates.....	54
4.2.3.8.1	Fences Requiring an EES	54
4.2.3.8.2	Fences Crossed by Overhead Power Lines	56
4.2.4	Earth Electrode System (EES) Requirements	57
4.2.4.1	General.....	57
4.2.4.2	Site Survey	57
4.2.4.3	Design	58
4.2.4.3.1	Chemical Enhancements.....	58
4.2.4.3.2	Chemical Rods.....	58
4.2.4.3.3	Engineered Soil Materials	58
4.2.4.3.4	Coke Breeze	58
4.2.4.3.5	Ground Dissipation Plates.....	59
4.2.4.3.6	Installation of Earth Electrode Systems in Corrosive Soils.....	59
4.2.4.3.7	Configuration	61
4.2.4.3.8	Ground rods.....	61
4.2.4.3.9	Interconnections	61
4.2.4.3.10	Access Well.....	61
4.2.5	Main and Supplemental Ground Plates.....	62
4.2.6	General Grounding and Bonding Requirements	62
4.2.6.1	Secure Facilities	62
4.2.6.2	Electronic Signal Return Path.....	62
4.2.6.3	Interior Metal Piping Systems.....	63
4.2.6.4	Electrical Supporting Structures	63
4.2.6.4.1	Conduit.....	63
4.2.6.4.2	Cable Trays and Wireways	63
4.2.6.5	Building Structural Steel Bonding Requirements	64
4.2.6.6	High RF Field Bonding Requirements	64
4.2.7	Signal Reference Structures Requirements	65
4.2.7.1	Multipoint Ground Systems	66
4.2.7.1.1	Multipoint Ground Plates and Buses	67
4.2.7.1.2	Ground Conductors – Plate to Plate and Plate to Bus	67
4.2.7.1.3	Ground Conductors (Plate and Bus to Equipment).....	68
4.2.7.1.4	Protection.....	68

4.2.7.1.5	Conductor Labeling	68
4.2.7.2	Signal Reference Planes	69
4.2.7.3	Connection of MPG and SRP Systems to the Main and Supplemental Ground Plates	70
4.2.7.4	Connection of Electronic Enclosures to the SRS	70
4.2.8	Electronic Single Point Ground System Requirements	70
4.2.8.1	General	70
4.2.8.2	Ground Plates	70
4.2.8.3	Isolation between Single Point and SRP or MPG Systems	71
4.2.8.3.1	Resistance.....	71
4.2.8.4	Ground Conductors	71
4.2.8.4.1	Main Ground Conductor.....	71
4.2.8.4.2	Trunk and Branch Ground Conductors	71
4.2.8.4.3	Electronic Equipment Ground Conductors.....	71
4.2.8.5	Interconnections	71
4.2.8.6	Labeling.....	71
4.2.8.6.1	Conductor Identification	72
4.2.8.6.2	Ground Plate Labeling	72
4.2.8.6.3	Protection	72
4.2.9	DC Bus Grounding Requirements.....	73
4.2.10	National Electrical Code (NEC) Grounding Compliance.....	73
4.2.10.1	General	73
4.2.10.2	Grounding Electrode Conductors	74
4.2.10.3	Equipment Grounding Conductors	74
4.2.10.4	Color Coding of Conductors.....	75
4.2.10.4.1	Grounded Conductors.....	75
4.2.10.4.2	Equipment Grounding Conductors.....	75
4.2.10.4.3	Control and DC Power Cables and Conductors	75
4.2.10.5	Non-Current-Carrying Metal Equipment Enclosures	76
4.2.11	Airport Traffic Control Towers (ATCT) Special Requirements	76
4.2.11.1	General	77
4.2.11.2	Main Ground Connections	77
4.2.11.3	Power Distribution	77
4.2.11.4	Bonding.....	78
4.2.11.5	Signal, Communications, Axial Cables and Control Line Protection	78
4.2.11.6	Signal Reference Structure	79
4.2.11.7	Floor Coverings for Electronic Equipment and Operational Areas	79
4.2.11.8	Single Point Grounding.....	79
4.3	Equipment Requirements	79
4.3.1	Electronic Signal Lines and Cables	79
4.3.1.1	Termination of Individual Shields	79
4.3.1.2	Termination of Overall Shields	79
4.3.2	Signal Control and Data Line Entrance.....	79
4.3.2.1	Equipment Transient Levels	80
4.3.2.2	Lines and Cables Requiring Protection.....	80
4.3.3	Power Entrance.....	80
4.3.3.1	Slope Resistance	81
4.3.3.2	DC Power Supply Transient Suppression.....	82
4.3.3.3	Externally Mounted Electronic Equipment.....	83
4.3.4	Electronic Equipment Grounding	83
4.3.4.1	Electronic Cabinets, Racks, and Cases.....	83
4.3.4.2	Isolated Grounding Receptacles.....	83
4.3.4.3	Portable Equipment (with grounding conductor)	83
4.3.4.4	AC Power Filters	83
4.3.5	Equipment Signal Grounding Requirements	83
4.3.5.1	Input and Output Electronic Signals.....	84

4.3.5.2	Multipoint Grounding of Electronic Equipment.....	84
4.3.5.2.1	Prevention of Resonance in Bonding Straps.....	84
4.3.5.3	Single Point Grounding of Electronic Equipment.....	84
4.3.5.3.1	Single Point Input and Output Signal Requirements.....	84
4.3.5.3.2	Single Point Case Isolation Requirements.....	84
4.3.5.3.3	Single Point Power Isolation Requirements.....	85
4.3.5.4	Equipment Single Point Ground Terminals.....	85
4.3.5.4.1	Connection of Electronic Equipment to the Single Point Ground System.....	85
4.3.6	Equipment Shielding Requirements.....	87
4.3.6.1	Control of Apertures.....	87
4.3.6.2	Metal Control Shafts.....	87
4.3.6.3	Shielded Compartments.....	87
4.3.7	Circuit and Equipment ESD Design Requirements.....	87
4.3.7.1	Circuit Design and Layout.....	87
4.3.7.2	Component Protection.....	87
4.3.7.3	ESD Withstand Requirements.....	87
5	DETAILED REQUIREMENTS.....	89
6	NOTES.....	91
6.1	Acronyms and Abbreviations.....	91
6.2	Guidelines.....	92
6.3	Version Cross-Reference.....	92
1	SCOPE.....	1
1.1	Scope.....	1
1.2	Purpose.....	1
2	APPLICABLE DOCUMENTS.....	3
2.1	Government Documents.....	3
2.2	Non-Government Documents.....	4
3	DEFINITIONS.....	7
3.1	Access Well.....	7
3.2	Air Terminal.....	7
3.3	Armored Cable.....	7
3.4	Arrester.....	7
3.5	Bond.....	7
3.6	Bond, Direct.....	7
3.7	Bond, Indirect.....	7
3.8	Bonding.....	7
3.9	Bonding Jumper.....	7
3.10	Branch Circuit.....	7
3.11	Building.....	7
3.12	Bulkhead Plate.....	8
3.13	Cabinet.....	8
3.14	Cable.....	8

3.14.1	Cable, AC (not the same as armored (DEB) cable).....	8
3.14.2	Cable, Armored Direct Earth Burial (DEB).....	8
3.14.3	Cable, Axial	8
3.14.4	Cable, Shielded	8
3.15	Case	8
3.16	Catenary Wire	8
3.17	Chassis	8
3.18	Clamp Voltage	8
3.19	Conductor, Bare.....	8
3.20	Conductor, Insulated	9
3.21	Conductor, Lightning Bonding (Secondary)	9
3.22	Conductor, Lightning Down.....	9
3.23	Conductor, Lightning Main	9
3.24	Conductor, Lightning Roof	9
3.25	Crowbar	9
3.26	Earth Electrode System (EES)	9
3.27	Electromagnetic Interference (EMI).....	9
3.28	Electronic Multipoint Ground System	9
3.29	Electronic Single Point Ground (SPG) System	9
3.30	Enclosed Ferrous Cable Tray	10
3.31	Equipment Areas	10
3.32	Equipment Grounding Conductor	10
3.33	Equipment	10
3.34	Facility Ground System.....	10
3.35	Faraday Cage	10
3.36	Feeder	10
3.37	Ferrous Conduit	10
3.38	Fitting, High Compression	10
3.39	Ground	10
3.40	Grounded Conductor.....	10
3.41	Grounded	11
3.42	Grounding Conductor.....	11
3.43	Grounding Electrode	11
3.44	Grounding Electrode Conductor	11
3.45	High frequency	11
3.46	Horizontal Transitions	11
3.47	Jordan Dissipation Plate Design	11
3.48	Landline	11
3.49	Line Replaceable Unit	11
3.50	Low Frequency	12
3.51	Main Service Disconnect.....	12

3.52	National Electrical Code.....	12
3.53	Operational Areas.....	12
3.54	OPR	12
3.55	Overshoot Voltage	12
3.56	Pressure Connector	12
3.57	Rack	12
3.58	Reference Plane or Point, Electronic Signal (Signal Ground)	12
3.59	Rigid Metal Conduit (RMC).....	12
3.60	RGS	12
3.61	Shield.....	13
3.62	Signal.....	13
3.63	Standard Version.....	13
3.64	Structure	13
3.65	Surge	13
3.66	Susceptibility Level	13
3.67	Transient	13
3.68	Transient Suppressor.....	13
3.69	Turn-on Voltage	13
3.70	Zone of Protection	13
4	GENERAL REQUIREMENTS	15
4.1	Requirements Common to Both Facilities and Equipment.....	15
4.1.1	Bonding Requirements	15
4.1.1.1	Resistance of Bonds.....	15
4.1.1.2	Methods of Bonding	15
4.1.1.2.1	Exothermic Welds	15
4.1.1.2.2	Welded Assemblies	16
4.1.1.2.3	Dissimilar Metals	16
4.1.1.2.4	Mechanical Connections	18
4.1.1.3	Bonding Straps and Jumpers	19
4.1.1.4	Fasteners	20
4.1.1.5	Temporary Bonds.....	20
4.1.1.6	Inaccessible Locations.....	20
4.1.1.7	Surface Preparation	21
4.1.1.7.1	Area to Be Cleaned	21
4.1.1.7.2	Final Cleaning.....	21
4.1.1.7.3	Completion of the Bond	21
4.1.1.7.4	Refinishing of Bond	21
4.1.1.7.5	Surface Plating or Treatments	21
4.1.1.8	Bond Protection	21
4.1.1.8.1	Paint.....	21
4.1.1.8.2	Compression Bonds in Protected Areas	22
4.1.1.8.3	Corrosion Protection	22
4.1.1.9	Bonding across Shock Mounts	22
4.1.1.10	Enclosure Bonding	22
4.1.1.11	Subassemblies	22
4.1.1.12	Equipment.....	22
4.1.1.13	Connector Mounting	23

4.1.1.14	Shield Terminations	23
4.1.1.15	RF Gaskets	23
4.1.2	Shielding Requirements.....	24
4.1.2.1	Design	24
4.1.2.2	Facility Shielding	24
4.1.2.3	Conductor and Cable Shielding	24
4.1.2.3.1	Signal Lines and Cables	24
4.1.2.3.2	Termination of Individual Shields	24
4.1.2.3.3	Termination of Overall Shields	25
4.1.2.4	Electromagnetic Environment Control	27
4.1.2.4.1	Space Separation	27
4.1.2.4.2	Wire and Cable Routing	27
4.1.2.4.3	Gaskets	28
4.1.2.4.4	Filter Integration	28
4.1.2.4.5	Bonding and Grounding of Compartment Shields	28
4.1.3	Electrostatic Discharge (ESD) Requirements	28
4.1.3.1	ESD Sensitivity Classification	29
4.1.3.2	ESD Protection Requirements	29
4.1.3.3	Classification of Materials	29
4.1.3.3.1	General	29
4.1.3.3.2	Static Conductive Materials	29
4.1.3.3.3	Electrostatic Shielding Materials	29
4.1.3.3.4	Electromagnetic Shielding Materials	30
4.1.3.3.5	Static Dissipative Materials	30
4.1.3.3.6	Antistatic Materials	30
4.1.3.3.7	Static-Generative Materials, Non-Conductors, and Insulators	30
4.1.3.4	Protection of ESD Susceptible and Sensitive Items	30
4.1.3.4.1	Static Protected Zone	30
4.1.3.4.2	ESD Special Protection Areas	31
4.1.3.4.3	ESD Controls Required for ESD Special Protection Areas	31
4.1.3.4.4	ESD Signs, Labels, Cautions, and Warnings.....	32
4.1.3.4.5	ESD Protected Workstations.....	32
4.1.3.4.6	ESD Protective Storage Areas	33
4.1.3.4.7	Hard and Soft Grounds.....	34
4.1.3.4.8	ESD Control Flooring and Floor Coverings.....	34
4.1.3.4.9	ESD Requirements for Raised Floors	35
4.1.3.4.10	ESD Protective Worksurfaces.....	35
4.1.3.4.11	Static Dissipative Coatings	36
4.1.4	Electromagnetic Compatibility Requirements	36
4.1.4.1	General.....	36
4.1.4.2	Requirements.....	37
4.1.4.3	Approval.....	37
4.2	Facility Requirements	37
4.2.1	Passive Transient Protection Requirements	37
4.2.1.1	Existing Metallic Conduit, Conductors and Cables	37
4.2.1.2	Electromagnetic Shielding for Lines, Conductors and Cables.....	37
4.2.1.2.1	Facility Entrance Conduit.....	38
4.2.1.2.2	Buried External Power Cables and Conductors	38
4.2.1.2.3	Buried Landlines	38
4.2.1.2.4	Conduit Joints and Fittings	38
4.2.1.3	Above Ground Ferrous Conduit Penetration of Facility	38
4.2.1.4	Armored Direct Earth Burial (DEB) Cables	39
4.2.1.5	Guard Wires	39
4.2.1.6	Metal Bulkhead Connector Plates	39
4.2.1.7	Balanced Pair Lines	40

4.2.1.8	Fiber Optic Cable	40
4.2.1.9	Interior Lines, Conductors and Cables	40
4.2.2	Active Transient Protection Requirements.....	40
4.2.2.1	Conducted Power Line Surges	41
4.2.2.2	Facility Entrance Surge Protective Devices	41
4.2.2.3	Surge Protective Devices for Feeder and Branch Panels	41
4.2.2.4	SPD General Requirements.....	42
4.2.2.4.1	SPD Operational Characteristics	42
4.2.2.4.2	Surge Levels	43
4.2.2.4.3	Slope Resistance.....	44
4.2.2.4.4	3kA Voltages V_3	44
4.2.2.4.5	Indicator Lamps	44
4.2.2.4.6	Accessibility.....	45
4.2.2.5	Signal, Control, and Data Line Protection Design	45
4.2.2.6	SPD Requirements for Signal Data and Control Lines.....	46
4.2.2.6.1	Signal, Control, and Data Line Protection Requirements	46
4.2.2.7	Axial Cable Protection Design.....	47
4.2.3	Lightning Protection System Requirements	47
4.2.3.1	General.....	47
4.2.3.2	Lightning Protection System Materials.....	48
4.2.3.2.1	Lightning Protection System Conductors.....	48
4.2.3.2.2	Lightning Protection System Hardware.....	48
4.2.3.2.3	Guards	48
4.2.3.3	Lightning Protection System Bonds.....	48
4.2.3.3.1	Metallic Bodies Subject to Direct Lightning Strikes	48
4.2.3.3.2	Metallic Bodies Subject to Induced Charges.....	49
4.2.3.3.3	Exhaust Stack Grounding.....	49
4.2.3.3.4	Above Ground Fuel and Oil Storage Tanks.....	49
4.2.3.4	Conductor Routing.....	49
4.2.3.4.1	Down Conductors on Fiberglass Mounting Poles	50
4.2.3.4.2	Down Conductor Terminations.....	50
4.2.3.5	Lightning Protection for Buildings and Structures	50
4.2.3.5.1	Air Terminals.....	50
4.2.3.5.2	ATCT Potential Equalization	51
4.2.3.5.3	Number of Down Conductors for Buildings.....	51
4.2.3.5.4	Metal Parts of Buildings.....	51
4.2.3.5.5	Roof Mounted Antenna Masts.....	51
4.2.3.6	Lightning Protection for Antenna Towers	52
4.2.3.6.1	Number of Down Conductors for Towers	52
4.2.3.6.2	Pole Type Towers	52
4.2.3.6.3	Towers without Radomes.....	52
4.2.3.6.4	Radomes	52
4.2.3.6.5	Towers with Radomes	53
4.2.3.6.6	Antenna Protection.....	54
4.2.3.6.7	Tower Guying	54
4.2.3.6.8	Waveguide, Axial Cable, and Conduit Grounding.....	54
4.2.3.6.9	Staircase/Ladder Protection	54
4.2.3.7	Lightning Protection for Facilities without Buildings or Antennas	55
4.2.3.8	Lightning Protection for Fences and Gates.....	55
4.2.3.8.1	Fences in High Risk Locations	56
4.2.3.8.2	Fence Grounding for High Risk Locations.....	56
4.2.3.8.3	Fences Crossed by Overhead Power Lines.....	58
4.2.4	Earth Electrode System (EES) Requirements	58
4.2.4.1	General.....	58
4.2.4.2	Site Survey	59
4.2.4.3	Design	59

4.2.4.3.1	Chemical Enhancements.....	59
4.2.4.3.2	Chemical Rods.....	59
4.2.4.3.3	Engineered Soil Materials.....	59
4.2.4.3.4	Coke Breeze.....	60
4.2.4.3.5	Ground Dissipation Plates.....	60
4.2.4.3.6	Installation of Earth Electrode Systems in Corrosive Soils.....	60
4.2.4.3.7	Configuration.....	62
4.2.4.3.8	Ground rods.....	62
4.2.4.3.9	Interconnections.....	62
4.2.4.3.10	Access Well.....	62
4.2.5	Main and Supplemental Ground Plates.....	63
4.2.6	General Grounding and Bonding Requirements.....	63
4.2.6.1	Secure Facilities.....	63
4.2.6.2	Electronic Signal Return Path.....	63
4.2.6.3	Interior Metal Piping Systems.....	64
4.2.6.4	Electrical Supporting Structures.....	64
4.2.6.4.1	Conduit.....	64
4.2.6.4.2	Cable Trays and Wireways.....	64
4.2.6.5	Building Structural Steel Bonding Requirements.....	65
4.2.6.6	High RF Field Bonding Requirements.....	65
4.2.7	Signal Reference Structures Requirements.....	66
4.2.7.1	Multipoint Ground Systems.....	67
4.2.7.1.1	Multipoint Ground Plates and Buses.....	68
4.2.7.1.2	Ground Conductors – Plate to Plate and Plate to Bus.....	68
4.2.7.1.3	Ground Conductors (Plate and Bus to Equipment).....	69
4.2.7.1.4	Protection.....	69
4.2.7.1.5	Conductor Labeling.....	69
4.2.7.2	Signal Reference Planes.....	70
4.2.7.3	Connection of MPG and SRP Systems to the Main and Supplemental Ground Plates.....	71
4.2.7.4	Connection of Electronic Enclosures to the SRS.....	71
4.2.8	Electronic Single Point Ground System Requirements.....	71
4.2.8.1	General.....	71
4.2.8.2	Ground Plates.....	71
4.2.8.3	Isolation between Single Point and SRP or MPG Systems.....	72
4.2.8.3.1	Resistance.....	72
4.2.8.4	Ground Conductors.....	72
4.2.8.4.1	Main Ground Conductor.....	72
4.2.8.4.2	Trunk and Branch Ground Conductors.....	72
4.2.8.4.3	Electronic Equipment Ground Conductors.....	72
4.2.8.5	Interconnections.....	72
4.2.8.6	Labeling.....	72
4.2.8.6.1	Conductor Identification.....	73
4.2.8.6.2	Ground Plate Labeling.....	73
4.2.8.6.3	Protection.....	73
4.2.9	DC Bus Grounding Requirements.....	74
4.2.10	National Electrical Code (NEC) Grounding Compliance.....	74
4.2.10.1	General.....	74
4.2.10.2	Grounding Electrode Conductors.....	75
4.2.10.3	Equipment Grounding Conductors.....	75
4.2.10.4	Color Coding of Conductors.....	76
4.2.10.4.1	Grounded Conductors.....	76
4.2.10.4.2	Equipment Grounding Conductors.....	76
4.2.10.4.3	Control and DC Power Cables and Conductors.....	76
4.2.10.5	Non-Current-Carrying Metal Equipment Enclosures.....	77
4.2.11	Airport Traffic Control Towers (ATCT) Special Requirements.....	77
4.2.11.1	General.....	78

4.2.11.2	Main Ground Connections	78
4.2.11.3	Power Distribution	78
4.2.11.4	Bonding	79
4.2.11.5	Signal, Communications, Axial Cables and Control Line Protection.....	79
4.2.11.6	Signal Reference Structure.....	80
4.2.11.7	Floor Coverings for Electronic Equipment and Operational Areas	80
4.2.11.8	Single Point Grounding	80
4.3	Equipment Requirements	80
4.3.1	Electronic Signal Lines and Cables	80
4.3.1.1	Termination of Individual Shields	80
4.3.1.2	Termination of Overall Shields	80
4.3.2	Signal Control and Data Line Entrance.....	80
4.3.2.1	Lines and Cables Requiring Protection.....	81
4.3.3	Power Entrance.....	81
4.3.3.1	Slope Resistance	82
4.3.3.2	DC Power Supply Transient Suppression.....	83
4.3.3.3	Externally Mounted Electronic Equipment	84
4.3.4	Electronic Equipment Grounding	84
4.3.4.1	Electronic Cabinets, Racks, and Cases.....	84
4.3.4.2	Isolated Grounding Receptacles.....	84
4.3.4.3	Portable Equipment (with grounding conductor)	84
4.3.4.4	AC Power Filters	84
4.3.5	Equipment Signal Grounding Requirements	84
4.3.5.1	Input and Output Electronic Signals.....	85
4.3.5.2	Multipoint Grounding of Electronic Equipment.....	85
4.3.5.2.1	Prevention of Resonance in Bonding Straps	85
4.3.5.3	Single Point Grounding of Electronic Equipment.....	85
4.3.5.3.1	Single Point Input and Output Signal Requirements.....	85
4.3.5.3.2	Single Point Case Isolation Requirements.....	85
4.3.5.3.3	Single Point Power Isolation Requirements	86
4.3.5.4	Equipment Single Point Ground Terminals	86
4.3.5.4.1	Connection of Electronic Equipment to the Single Point Ground System	86
4.3.6	Equipment Shielding Requirements.....	88
4.3.6.1	Control of Apertures.....	88
4.3.6.2	Metal Control Shafts.....	88
4.3.6.3	Shielded Compartments.....	88
4.3.7	Circuit and Equipment ESD Design Requirements	88
4.3.7.1	Circuit Design and Layout.....	88
4.3.7.2	Component Protection	88
4.3.7.3	ESD Withstand Requirements	88
5	DETAILED REQUIREMENTS	90
6	NOTES.....	92
6.1	Acronyms and Abbreviations.....	92
6.2	Guidelines	93
6.3	Version Cross-Reference	93

List of Figures

Figure I. Order of Assembly for Bolted Connections.....	19
Figure II. Bonding of Connectors to Mounting Surface.....	23
Figure III. Grounding of Overall Cable Shields to Connectors and Penetrating Walls	26
Figure IV. Grounding of Overall Cable Shield to Terminal Strip	27
Figure V. Lightning Protection for Radomes and Radar Antenna Platforms.....	53
Figure VI Common Collective Area of Increased Risk	56
Figure VII. Fence Grounding.....	57
Figure VIII. Grounding Fences Requiring an EES.....	58
Figure IX. Grounding Trench Detail	61
Figure X. Jordan Dissipation Plate Design.....	61
Figure XI. Facility Grounding System	67
Figure XII. Multipoint Ground Conductor Size Determination.....	69
Figure XIII. Electronic Single Point Ground System Installation	74
Figure XIV. Bonding of Conduit and Grounding Conductor.....	77
Figure XV. Airport Traffic Control Tower Levels	79
Figure XVI. Lines and Cables Requiring Protection	81
Figure XVII. Single Point Electronic Ground Bus Bar Installation in Rack or Cabinet.....	87

List of Tables

Table I. Mechanical Bonds Between Dissimilar Metals	17
Table II. Torque Requirements for Bolted Bonds	18
Table III. Minimum Separation Distance Between Signal and Power Conductors.	28
Table IV. Surge Current Lifetime Requirements	43
Table V. Entrance, Feeder, and Branch Panels Slope Resistance Requirements	44
Table VI. Protection Voltages at 3kA	44
Table VII. SPD Lifetime Conducted Landline Transient Level Requirements	47
Table VIII. Grounding Conductor Color Codes	65
Table IX. Size of Electronic Multipoint Ground Interconnecting Conductors	69
Table X. Equipment Power Entrance Slope Resistance Requirements	83
Table XI. Protection Voltages at 3kA for the Equipment Power Entrance	83
Table XII. Electronic Equipment Power Entrance SPD Requirements.....	83

This Page Intentionally Left Blank

1 SCOPE

1.1 Scope

This document mandates standard lightning protection, transient protection, grounding, bonding and shielding configurations and procedures and control of electrostatic discharge (ESD) for new facilities, modifications and upgrades to existing facilities, new equipment installations, and new electronic equipment used in the National Airspace Systems (NAS). It provides requirements for the design, construction, modification or evaluation of facilities and equipment. (It is recommended that the OPR of this document be contacted to obtain technical guidance on the applicability of the requirements to modifications, upgrades and new equipment installations in existing facilities.)

This document is not mandatory for programs that have been funded prior to the issue date of this document, nor is it mandatory for construction contracts associated with programs funded prior to the issue of the document. Application of this document is at the discretion of the user for programs that have been funded prior to the issue of the document. The Office of Primary Responsibility (OPR) can mandate the use of this document for programs started before the issue date of this document, if funding is provided.

The interface between contractor owned equipment or electronic equipment not used for operational purposes (administrative local area network (LAN), administrative telephone, etc.) and the operational facility shall be in accordance with this document.

1.2 Purpose

The requirements of this standard provide a systematic approach to minimize electrical hazards to personnel, electromagnetic interference and damage to facilities and electronic equipment from lightning, transients, ESD, and power faults.

This Page Intentionally Left Blank

2 APPLICABLE DOCUMENTS

2.1 Government Documents

Due to the continuous updating of Government documents, the Contracting Officer and/or the Implementation Engineer must specify the version current at contract award or project design. These documents form a part of this standard and are applicable to the extent specified elsewhere in this document. If conflicts occur between these documents and the contents of this standard, the contents of this standard provide the superseding requirements.

FAA Specifications

FAA-C-1217	Electrical Work, Interior
FAA-G-2100	Electronic Equipment, General Requirements
NAS-SS-1000	Functional and Performance Requirements for the National Airspace Air Traffic Control Element

FAA Orders

Order 6950.19	Practices and Procedures for Lightning Protection, Grounding, Bonding and Shielding Implementation
Order 6950.20	Fundamental Considerations of Lightning Protection, Grounding, Bonding and Shielding

(Copies of these specifications, standards, orders, and other applicable FAA documents may be obtained from the Contracting Officer issuing the invitation-for-bids or request-for-proposals. Requests should fully identify material desired, i.e. specification, standard, amendment, drawing numbers and dates. Requests should cite the invitation-for-bids, request-for-proposals, the contract involved, or other use to be made of the requested material.)

Military Documents

MIL-HDBK-232	Revision A Red/Black Engineering-Installation Guidelines
MIL-HDBK-237	Electromagnetic Compatibility Management Guide for Platforms, Systems and Equipment
MIL-HDBK-253	Guidance for the Design and Test of Systems Protected Against the Effects of Electromagnetic Energy
DOD/MIL-HDBK-263	Electrostatic Discharge Control Handbook
DOD-STD-1686	Electrostatic Discharge Control Program for Protection of Electrical and Electronic Parts, Assemblies and Equipment (Excluding Electrically Initiated Explosive Devices)
MIL-HDBK-419	Grounding, Bonding, and Shielding for Electronic Equipment and Facilities
MIL-PRF-87893	Performance Specification, Workstations, Electrostatic Discharge Control

MIL-W-87893	Military Specification, Workstations, Electrostatic Discharge (ESD) Control
MIL-STD-461	The Control of Electromagnetic Interference Emissions and Susceptibility
MIL-STD-889	Dissimilar Metals
MIL-STD-1686	Electrostatic Discharge Control Program for Protection of Electrical and Electronic Parts, Assemblies, and Equipment (Excluding Electrically Initiated Explosive Devices)
NACSIM 5203	Guidelines for Facility Design and Red/Black Installation (Confidential Document)

Single copies of Military specifications, standards, and handbooks may be requested by mail or telephone from Document Automation and Production Service Customer Service, Standardization Documents Order Desk, 700 Robbins Avenue, Building 4D Philadelphia, PA 19111-5094 or via dodssp.daps.dla.mil. Not more than five items may be ordered on a single request; the Invitation for Bid or Contract Number should be cited where applicable. Only latest revisions (complete with latest amendments) are available; slash sheets must be individually requested. Request all items by document number.

2.2 Non-Government Documents

Due to the continuous updating of Non-Government documents, the Contracting Officer and/or the Implementation Engineer must specify the version current at contract award or project design unless a specific version is called out in the requirements of this standard. These documents form a part of this standard and are applicable to the extent specified herein. While this standard may exceed the requirements of the following documents, Nationally required practices shall always be performed as a minimum.

Electronic Industries Alliance (EIA)

EIA Standard EIA-625	Requirements for Handling Electrostatic-Discharge-Sensitive (ESDS) Devices
----------------------	--

Requests for copies of EIA Standards should be addressed to Electronic Industries Alliance, Corporate Engineering Department, 2500 Wilson Boulevard, Arlington, VA 22201 or telephone 703 907-7500. www.eia.org

National Fire Protection Association (NFPA)

NFPA 70	National Electrical Code (NEC)
NFPA 77	Static Electricity
NFPA 780	Standard for the Installation of Lightning Protection Systems

Requests for copies of NFPA documents should be addressed to the National Fire Protection Association, One Batterymarch Park, Quincy MA 02269. www.nfpa.org

Underwriters Laboratories, Inc. (UL)

UL 96	Lightning Protection Components
UL 96A	Installation Requirements for Lightning Protection Systems
UL 779 (ANSI-A148.1)	Electrically Conductive Floorings
UL 1449	Transient Voltage Surge Suppressors

Requests for copies of UL documents should be addressed to Global Engineering Documents, 1500 Inverness Way, East Englewood, CO 80112. Telephone 303 397-7945, 800 854-7179. www.ul.com

Institute of Electrical and Electronic Engineers (IEEE)

ANSI/IEEE C62.41	Recommended Practice on Surge Voltages in Low Voltage AC Power Circuits
ANSI/IEEE C62.45	IEEE Guide on Surge Testing for Equipment Connected to Low-Voltage AC Power Circuits
ANSI/IEEE 1100	Recommended Practice for Powering and Grounding Sensitive Electronic Equipment (Emerald Book)

Requests for copies of IEEE documents should be addressed to Institute of Electrical and Electronic Engineers, 445 Hoes Lane, P.O. Box 1331, Piscataway, NJ 08855-9916. www.ieee.org

Electrostatic Discharge (ESD) Association Documents

ESD ADV53.1	ESD Protective Workstations
ANSI/ESD S4.1	Worksurfaces – Resistance Measurements
ANSI/ESD S7.1	Floor Materials, Characterization of Materials
ANSI/ESD S8.1	Symbols – ESD Awareness
ANSI/ESD S11.11	Surface Resistance Measurement of Static Dissipative Planar Materials
ANSI/ESD S20.20	Development of an Electrostatic Discharge Control Program for Protection of Electrical and Electronic Parts, Assemblies and Equipment
ANSI/ESD STM5.1	Sensitivity Testing, Human Body Model (HBM), Component Level
ANSI/ESD STM12.1	Seating - Resistive Measurement
ESD TR20.20	Development of an Electrostatic Discharge Control Program for Protection of Electrical and Electronic Parts, Assemblies and Equipment – Handbook

Requests for copies of ESD Association documents should be addressed to the ESD Association, 7900 Turin Road, Bldg 3, Suite 2, Rome, NY 13440-2069. Telephone 315 339-6937. www.esda.org

This Page Intentionally Left Blank

3 DEFINITIONS

3.1 Access Well

A covered opening in the earth using concrete, clay pipe or other wall material to provide access to an EES connection.

3.2 Air Terminal

That component of a lightning protection system specifically designed to accept lightning strikes.

3.3 Armored Cable

Power, signal, control or data cable having an overall armor or covering constructed of ferrous (steel) material that provides both structural protection and electromagnetic shielding for direct buried cables.

3.4 Arrester

Components, devices or circuits used to attenuate, suppress, limit, and/or divert adverse electrical (surge and transient) energy. The terms arrester, suppressor and protector are used interchangeably except that the term arrester is used herein for components, devices and circuits at the service disconnecting means.

3.5 Bond

The electrical connection between two metallic surfaces used to provide a low resistance path between them.

3.6 Bond, Direct

An electrical connection utilizing continuous metal-to-metal contact between the members being joined.

3.7 Bond, Indirect

An electrical connection employing an intermediate electrical conductor between the bonded members.

3.8 Bonding

The joining of metallic parts to form an electrically conductive path to assure electrical continuity and the capacity to conduct current imposed between the metallic parts.

3.9 Bonding Jumper

A conductor installed to assure electrical conductivity between metal parts required to be electrically connected.

3.10 Branch Circuit

The circuit conductors between the final overcurrent device protecting the circuit and the load served.

3.11 Building

The fixed or transportable structure which provides environmental protection.

3.12 Bulkhead Plate

A metallic plate located where conduits, conductor, waveguides etc first enter the facility. The bulkhead plate provides a central point for the grounding of conduits, conductors and waveguides entering the facility or structure.

3.13 Cabinet

An enclosure designed either for surface mounting or flush mounting and is provided with a frame, mat, or trim in which a swinging door or doors are or can be hung.

3.14 Cable

A fabricated assembly of one or more conductors in a single outer insulation. Types include axial, armored and shielded.

3.14.1 Cable, AC (not the same as armored (DEB) cable)

Type AC cable is a fabricated assembly of insulated conductors in a flexible metallic enclosure.

3.14.2 Cable, Armored Direct Earth Burial (DEB)

Cable with a ferrous shield designed to provide both physical and electromagnetic protection to the conductors.

3.14.3 Cable, Axial

Cable where all conductors are oriented on a single axis. Examples include coaxial, biaxial, and triaxial cables

3.14.4 Cable, Shielded

Cable with a metalized or braid shield to improve resistance to electromagnetic interference (EMI).

3.15 Case

A protective housing for a unit or piece of electrical or electronic equipment.

3.16 Catenary Wire

A catenary lightning protection system consisting of one or more overhead ground wires and supporting masts.

3.17 Chassis

The metal structure that supports the electrical or electronic components which make up the unit or system.

3.18 Clamp Voltage

Clamp voltage is the voltage that appears across the SPD terminals when the suppressor is conducting a surge or transient current.

3.19 Conductor, Bare

An electrical conductor that has no covering or electrical insulation.

3.20 Conductor, Insulated

An electrical conductor encased within material of composition and thickness recognized by the NEC as electrical insulation.

3.21 Conductor, Lightning Bonding (Secondary)

An electrical conductor used to bond a metal object, within the zone of protection and subject to currents induced by lightning strikes, to the lightning protection system.

3.22 Conductor, Lightning Down

The down conductor serves as the path to the earth grounding system from the roof system of air terminals and roof conductors or from an overhead ground wire.

3.23 Conductor, Lightning Main

The main conductors are the conductors intended to carry lightning currents between air terminals and ground terminations. These can be the roof conductors interconnecting the air terminals on the roof, the conductor to connect a metal object on or above roof level that is subject to a direct lightning strike to the lightning protection system, or the down conductor.

3.24 Conductor, Lightning Roof

Roof conductors interconnecting all air terminals to form a two-way path to ground from the base of each air terminal.

3.25 Crowbar

The term “crowbar” refers to a method of shorting a surge, voltage, or current using surge protective devices.

3.26 Earth Electrode System (EES)

A network of electrically interconnected rods, plates, mats, piping, incidental electrodes (metallic tanks, etc.) or grids installed below grade to establish a low resistance contact with earth.

3.27 Electromagnetic Interference (EMI)

Any emitted, radiated, conducted or induced voltage which degrades, obstructs, or interrupts the desired performance of electronic equipment.

3.28 Electronic Multipoint Ground System

An electrically continuous network consisting of interconnected ground plates, equipment racks, cabinets, conduit junction boxes, raceways, duct work, pipes, copper grid system, building steel, and other non-current-carrying metal elements. It includes conductors, jumpers and straps that connect individual items of electronic equipment to the SRP or MPG system.

3.29 Electronic Single Point Ground (SPG) System

An SPG signal reference network provides a single point reference in the facility for equipment that requires single point grounding. It consists of conductors, plates and equipment terminals, all of which are isolated from any other grounding system except at the main ground plate.

3.30 Enclosed Ferrous Cable Tray

A cable tray with steel sides and bottom with a steel cover or lid. This tray may have small holes and gaps.

3.31 Equipment Areas

Areas that contain electronic equipment used to support NAS operation. These include electronic equipment rooms, TELCO rooms, VORs, Radars etc.

3.32 Equipment Grounding Conductor

The conductor with the phase and neutral conductors used to connect non-current-carrying metal parts of equipment, raceways, and other enclosures to the system grounded conductor and/or to the grounding electrode conductors at the main service disconnecting means or at the point of origin (X_0 bond) of a separately derived system.

3.33 Equipment

A general term including materials, fittings, devices, appliances, fixtures, apparatus, machines, etc, used as a part of, or in connection with, an electrical installation.

3.34 Facility Ground System

Consists of the complete ground system at a facility including the EES , SRP or MPG system, electronic single point ground system (SPG), equipment grounding conductors, grounding electrode conductor(s), and lightning protection system.

3.35 Faraday Cage

A closed conducting surface, such as wire mesh, completely surrounding an object or person so as to protect from impinging electromagnetic waves.

3.36 Feeder

All circuit conductors between the service equipment or the source of a separately derived system and the final branch circuit overcurrent device.

3.37 Ferrous Conduit

Material composed of and/or containing iron. Rigid Galvanized Steel Conduit (RGS) thick walled threaded conduit (NEC Rigid Metal Conduit (RMC)). For the purpose of this document, conduits not adequate for magnetic shielding include Electrical Metallic Tubing (EMT), Intermediate Metal Conduit (IMC) and conduits made from silicon bronze and stainless steel.

3.38 Fitting, High Compression

See "Pressure Connector".

3.39 Ground

A conducting connection, whether intentional or accidental, between an electrical circuit or equipment and the earth, or to some conducting body that serves in place of the earth.

3.40 Grounded Conductor

A system or circuit conductor that is intentionally grounded at the service disconnecting means

or at the source of a separately derived system. This grounded conductor is the neutral conductor for the power system.

3.41 Grounded

Connected to earth through a connection of sufficiently low impedance and having sufficient current carrying capacity so that fault current which occurs cannot build up to voltages dangerous to personnel.

3.42 Grounding Conductor

A conductor used to connect equipment or the grounded circuit of a wiring system to the grounding electrode system. (In this standard, grounding conductors not related to or not used as part of NEC required electrical system grounding, are used for the electronic equipment grounding system).

3.43 Grounding Electrode

Copper rod, plate or wire embedded in the ground for the specific purpose of dissipating electric energy to the earth.

3.44 Grounding Electrode Conductor

The conductor used to connect the grounding electrode to the equipment grounding conductor and/or to the grounded (neutral) conductor of the facility at the service disconnecting means or at the source of a separately derived system.

3.45 High frequency

All electrical signals at frequencies greater than 100 kilohertz (kHz), and pulse and digital signals with rise and fall times of less than 10 μ s are classified as high frequency signals.

3.46 Horizontal Transitions

Architectural term used to describe horizontal elements in a vertical structure (floors stair landings, etc.).

3.47 Jordan Dissipation Plate Design

Based on original design from W. Jordan FAA OKC.

3.48 Landline

Any conductor, line or cable installed externally above or below grade to interconnect electronic equipment in different facility structures or to interconnect externally mounted electronic equipment.

3.49 Line Replaceable Unit

Hardware elements whose design enables removal, replacement and checkout by organizational maintenance.

3.50 Low Frequency

Includes all voltages and currents, whether signal, control, or power, up to and including 100 kHz. Pulse and digital signals with rise and fall times of 10 μ s or greater are considered to be low frequency signals.

3.51 Main Service Disconnect

Main Service Disconnect is a switch, fused switch or circuit breaker that disconnects main service AC power (generally utility power) from a facility. Also referred to as Service Disconnecting Means (SDM).

3.52 National Electrical Code

A standard containing provisions that govern the use of electrical wire, cable, equipment and fixtures installed in buildings.

3.53 Operational Areas

Areas used to provide NAS support such as IFR rooms, ARTCC control rooms, ATCT tower cabs and operations control centers.

3.54 OPR

OPR is an acronym for Office of Primary Responsibility. The OPR is assigned to maintain and interpret this standard.

3.55 Overshoot Voltage

The fast rising voltage that appears across transient suppressor terminals before the suppressor turns on (conducts current) and clamps the input voltage to a specified level.

3.56 Pressure Connector

For purpose of this document, "FAA approved pressure connectors" shall be those that use hydraulically crimped terminations to effect closure.

3.57 Rack

A frame in which one or more equipment units are mounted.

3.58 Reference Plane or Point, Electronic Signal (Signal Ground)

The conductive terminal, wire, bus, plane, or network which serves as the relative zero potential for all associated electronic signals.

3.59 Rigid Metal Conduit (RMC)

A threadable raceway of circular cross section designed for the physical protection and routing of conductors and cables and for use as an equipment grounding conductor when installed with its integral or associated coupling and appropriate fittings.

3.60 RGS

See Ferrous Conduit.

3.61 Shield

A housing, shield, or cover which substantially reduces the coupling of electric and magnetic fields into or out of circuits or prevents accidental contact of objects or persons with parts or components operating at hazardous voltage levels.

3.62 Signal

Any electromagnetic transmission of information or control function. A signal can be analog, digital data or a control function such as a relay closure.

3.63 Standard Version

The applicable version of the standard is that issue in effect on the date of a contract signing.

3.64 Structure

Any fixed or transportable building, shelter, tower, or mast that is intended to house electrical or electronic equipment or otherwise support or function as an integral element of the air traffic control system.

3.65 Surge

An overvoltage or overcurrent of short duration occurring on a power line.

3.66 Susceptibility Level

The electronic equipment susceptibility level is the least of the damage, degradation, or upset levels considering all electronic components potentially affected by conducted or radiated transients.

3.67 Transient

An overvoltage or overcurrent pulse on a power, signal, control, or data line.

3.68 Transient Suppressor

Components, devices or circuits designed for the purpose of attenuating, absorbing and suppressing conducted transient and surge energy to protect facility equipment.

3.69 Turn-on Voltage

The voltage required across transient suppressor terminals to cause the suppressor to conduct current.

3.70 Zone of Protection

The zone of protection is that space adjacent to a lightning protection system that has a reduced probability of receiving a direct lightning strike.

This Page Intentionally Left Blank

4 GENERAL REQUIREMENTS

4.1 Requirements Common to Both Facilities and Equipment

This section provides requirements that are established to ensure the proper operation of FAA facilities and equipment. The use of the term “facilities” in this document can differ from the manner in which it is frequently used in other FAA documents. In this document, physical proximity of equipment(s) defines a single facility, while physical separation would define separate facilities. For example, the cab and electronic/electrical equipment located on the junction and subjunction levels of an Airport Traffic Control Tower (ATCT) are a single facility. An ATCT with a base building containing electronic equipment is an example of two facilities located at the same site. Other examples of two or more facilities include the ARSR-4 (the tower and base building are separate facilities) and Air Route Traffic Control Centers (ARTCC) with multiple buildings that must be treated as separate facilities. An example of a single facility (for purposes of this document) is a Remote Controlled Air to Ground Site (RCAG) collocated in a VHF Omni-directional Range (VOR) building. Contact the Office of Primary Responsibility (OPR) of this document for specific guidance on new facilities/systems.

4.1.1 Bonding Requirements

4.1.1.1 Resistance of Bonds

Unless otherwise specified in this standard, all bonds shall have a maximum DC resistance of 1 milliohm when measured between the bonded components with a 4-terminal milliohm meter.

4.1.1.2 Methods of Bonding

Bonding for electrical purposes shall be accomplished by a method that provides the required degree of mechanical strength, achieves the value of low and high frequency impedance required for proper functioning of the equipment. Soft soldered or brazed connections shall not be used for any part of the power grounding system, EES or the lightning protection system (air terminals, roof conductors, down conductors, fasteners, and conduit). Soft solder shall only be used to improve conductivity at joints already secured with mechanical fasteners. Soft solder shall not be used to provide mechanical restraint.

4.1.1.2.1 Exothermic Welds

Exothermic welds shall be allowed for any type of bond connection specified herein. Exothermic welds shall be used for all buried or subject to submersion connections. Where exothermic welds are not possible between certain materials, shapes, or in hazardous locations, i.e., near fuel tanks, where nearby objects are subject to damage, etc., connections using UL listed connectors shall be permitted. Exothermic welding shall be used for the permanent bonding of copper conductors to steel. Where the combustion products of a standard exothermic weld present problems, a smokeless exothermic process is commercially available and shall be used. All residual fluxes shall be removed or neutralized to prevent corrosion.

4.1.1.2.2 Welded Assemblies

Individual components of a welded assembly shall not require additional bonds between components if the DC resistance between individual components is less than 1 milliohm.

4.1.1.2.3 Dissimilar Metals

Mechanical bonds shall comply with Table I unless specifically approved by the OPR.

The legend shown below is for Table I and represents the four basic categories of possible metal interfaces.

no	Not suitable. This interface is highly likely to result in significant corrosion.
•	Suitable for indoor environments where temperature and humidity are controlled (non-condensing environment).
••	Suitable for all indoor environment.
•••	Suitable for all environments.

Table I. Mechanical Bonds Between Dissimilar Metals

METAL	Copper, solid or plate	Brass and bronze	Stainless Steel	Tin-plate; tin-lead solder	Aluminum, wrought alloys of the 2000 Series	Iron, wrought, gray or malleable, plain carbon and low alloy steels	Aluminum, wrought alloys other than 2000 Series aluminum, cast alloys of the silicon type	Aluminum, cast alloys other than silicon type, plated and chromate	Galvanized steel	Zinc, wrought; zinc-base die-casting alloys; zinc plated
Copper, solid or plate	•••	•••	••	•	•	•	no	no	no	no
Brass and bronze	•••	•••	••	••	•	•	•	no	no	no
Stainless Steel	••	••	•••	•••	•••	••	•	•	no	no
Tin-plate; tin-lead solder	•	••	•••	•••	•••	••	••	•	no	no
Aluminum, wrought alloys of the 2000 Series	•	•	•••	•••	•••	•••	•••	••	•	•
Iron, wrought, gray or malleable, plain carbon and low alloy steels	•	•	••	••	•••	•••	•••	•••	•	•
Aluminum, wrought alloys other than 2000 Series aluminum, cast alloys of the silicon type	no	•	•	••	•••	•••	•••	•••	•	•
Aluminum, cast alloys other than silicon type, plated and chromate	no	no	•	•	••	•••	•••	•••	••	•
Galvanized steel	no	no	no	no	•	•	•	••	•••	•••
Zinc, wrought; zinc-based die-casting alloys; zinc plated	no	no	no	no	•	•	•	•	•••	•••

4.1.1.2.4 Mechanical Connections

4.1.1.2.4.1 Coupling of Dissimilar Metals

Compression bonding with bolts and clamps should be used between metals having acceptable couples depending on the location as shown in

Table I. When the base metals form couples that are not allowed, the metals shall be coated, plated, or otherwise protected with a conductive finish. MIL-STD-889 provides specific information in this area.

4.1.1.2.4.2 Bolted Connections for Electrical Bonding

Bolts shall be used primarily as mechanical fasteners for holding the component members of the bond in place. Bolts shall be tightened sufficiently to maintain the contact pressures required for effective bonding but shall not be over-tightened to the extent that deformation of bond members occurs. Disc springs (Belleville spring washers) shall be installed on all bolted connections ¼ inches diameter and greater to prevent loosening. Bolted joints other than those intentionally used to attach bonding straps or conductors, shall not be used in lieu of dedicated bonding jumpers.

- a) All bolted connections ¼ inches diameter and greater shall conform to the torque requirements in Table II.
- b) All bolted connections in corrosive, damp, or wet locations, ¼ inches diameter and greater shall utilize stainless steel bolts, nuts, and load distribution washers to meet the strength requirements of same size SAE Standard J429 Grade 5. All other locations shall use corrosion inhibited SAE Standard J429 Grade 5 nuts and bolts. Load distribution washers shall comply with ANSI B18.22.1 for stainless steel washers, Wide Series, Type B.
- c) Bolted connections ¼ inches diameter and greater shall be assembled in the order shown in Figure I. Additional load distribution washers, if used, shall be positioned directly underneath the bolt head. Disc springs shall be between the nut and the load distribution washer. Washers shall not be placed between bonded members. Load distribution washers be wide Series, Type B.

Table II. Torque Requirements for Bolted Bonds

Bolt Size	Torque (ft-lbs)	Bolt Load (lbs)	Washers Required	Solon Part Number*
1/4 in.	10	2500	3	4-EH-70-301
5/16 in.	21	4000	3	5-EH-80-301
3/8 in.	34	5500	3	6-EH-89-301
7/16 in.	55	7500	6	7-L-70-301
1/2 in.	83	10,000	2	8-18-125-301
9/16 in.	117	12,500	N/A	N/A
5/8 in.	167	16,000	3	10-EH-150-177
3/4 in.	288	23,000	3	12-EH-168-177
7/8 in.	452	31,000	3	14-EH-168-177
1 in.	567	40,000	3	15-H-187-177

*Other manufacturers of disc spring washers are equally suitable

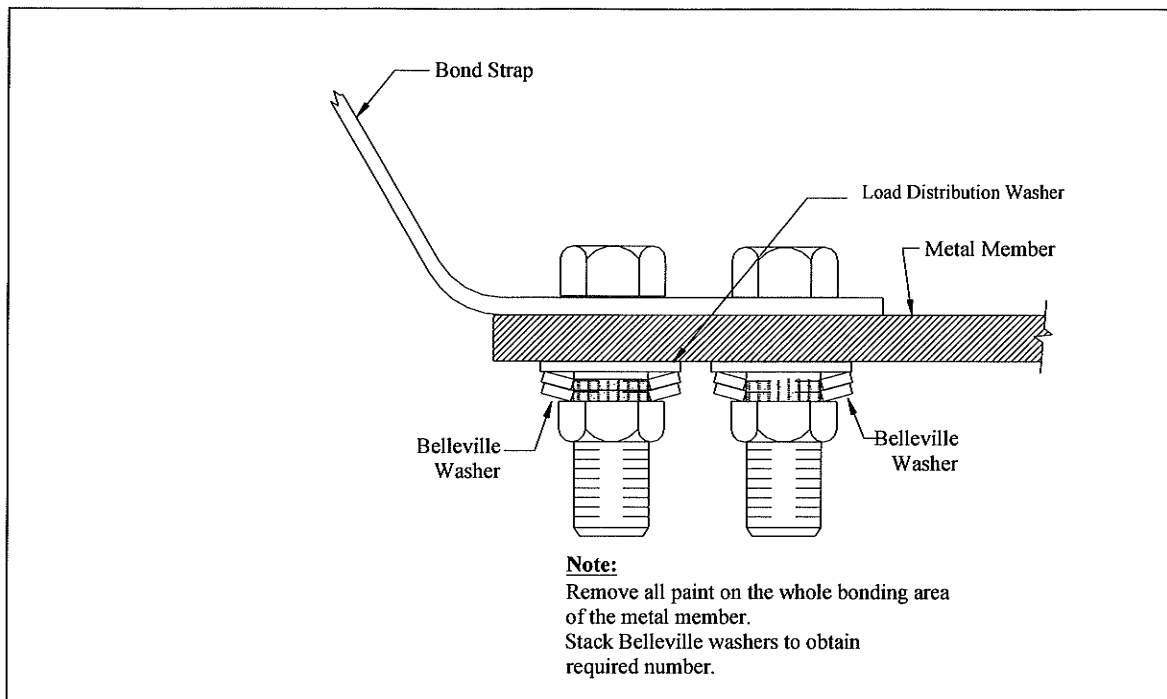

Figure I. Order of Assembly for Bolted Connections

4.1.1.2.4.3 Sheet Metal Screws

Sheet metal screws shall not be used to provide an electrical bond.

4.1.1.2.4.4 Hydraulically Crimped Terminations

Where crimped connectors are used for conductors 6 AWG or larger, the connectors shall be accomplished hydraulically using a minimum force of 12 tons concentrically applied.

4.1.1.2.4.5 Soldering

The use of silver solder to improve mechanical bonds by excluding contaminants from the mating surfaces shall be allowed. Mechanical bonds shall be mechanically secured prior to applying solder to prevent cold solder joints. Soldered mechanical connections shall not be used for any part of the power grounding system or the lightning protection system. See FAA Order 6950.20, Chapter 5, paragraph 99 for additional information.

4.1.1.2.4.6 Riveting

Rivets shall be employed solely as mechanical fasteners to hold multiple smooth, clean metal surfaces together or to provide a mechanical load bearing capability to a soldered bond.

4.1.1.3 Bonding Straps and Jumpers

Bonding straps, including jumpers, shall conform to the following:

- (a) Bonding jumpers shall be insulated except those used under a raised floor which shall be bare. Bonding jumpers for structural steel, rebar, connected to the EES, the lightning protection system, and any plenum or environmental airspace shall be bare also. Short bonding straps may be bare. (This requirement is to maintain compliance with the requirements of the NEC)
- (b) Bonding straps shall be attached to the basic component rather than through any adjacent parts.
- (c) Bonding straps shall be installed so that the electrical bond is not affected by motion or vibration.
- (d) Braided bonding straps shall not be used for bonding transmitters or other sources of radio frequency (RF) fields.
- (e) Bonding straps shall be installed whenever possible in areas accessible for maintenance and inspection.
- (f) Bonding straps shall be installed so they will not restrict movement of the components being bonded or other components nearby which must be able to move as part of normal functional operation.
- (g) Two or more bonding straps shall not be connected in series to provide a single bonding path.
- (h) The method of installation and point of attachment of bonding straps shall not weaken the components to which they are attached.
- (i) Bonding straps shall not be compression-fastened through non-metallic material.
- (j) Bonding straps shall be designed not to have resonant impedances at equipment operating frequencies. Two short, low-impedance grounding straps between the signal reference structure and two corners of the equipment should be used. These straps shall be connected as far apart as possible on the equipment (ideally on opposite corners) in order to reduce mutual inductance and they shall have few bends or sags. Two straps with a 20% to 30% difference in length should be used so that if one strap experiences resonance, limiting current flow, the other strap will not.
- (k) The length of the equipment bonding conductor connections shall be as short as possible and ideally be limited to 1/20th of a wavelength of the signal frequency, e.g., about six inches at 100 MHz.
- (l) Broad flat conductors, with a large surface area (at least one inch wide) shall be used for bonding straps since they have a lower inductance than round conductors. All bonding straps shall be fabricated with integral terminations that approximate the width of the strap, permitting proper terminations. Lower impedance can be achieved by multiple bonds.

4.1.1.4 Fasteners

Fastener materials for bonding aluminum and copper jumpers to structures shall conform to the materials listed in Table I.

4.1.1.5 Temporary Bonds

Alligator clips and other spring loaded clamps shall be employed only as temporary bonds while performing repair work on equipment or facility wiring.

4.1.1.6 Inaccessible Locations

All bonds in permanently concealed or inaccessible locations shall be exothermically welded.

4.1.1.7 Surface Preparation

All surfaces to be bonded shall be thoroughly cleaned to remove all dirt, grease, oxides, nonconductive films, or other foreign material. Paints and other coatings shall be removed to expose the base metal.

4.1.1.7.1 Area to Be Cleaned

Clean all surfaces at least $\frac{1}{4}$ inches (6.4 mm) beyond all sides of the larger bonded area on all mating surfaces.

4.1.1.7.2 Final Cleaning

Clean surfaces with a solvent suitable for electrical work immediately prior to assembly.

4.1.1.7.2.1 Clad Metals

Clean clad metal to a bright, shiny, smooth surface without penetrating the cladding. Wipe the cleaned area with solvent and allow to air dry before completing the bond.

4.1.1.7.2.2 Aluminum Alloys

A conductive finish shall be applied to aluminum mating surfaces after cleaning to a bright finish.

4.1.1.7.3 Completion of the Bond

Mating surfaces shall be joined within 2 hours after cleaning if an intentional protective coating has been removed from the metal surface. If delays beyond two hours are necessary in corrosive environments, the cleaned surfaces must be protected with an appropriate coating that must be removed before completion of the bond.

4.1.1.7.4 Refinishing of Bond

Where practicable restore areas around bonds so as to match the original finish.

4.1.1.7.5 Surface Plating or Treatments

Surface treatments that include plating provided for added abrasion resistance or corrosion protection shall offer high conductivity. Unless suitably protected from the atmosphere, silver and other easily tarnished metals shall not be used to plate bond surfaces, except where an increase in surface contact resistance cannot be tolerated.

4.1.1.8 Bond Protection

All bonds shall be protected against weather, corrosive atmospheres, vibration, and mechanical damage. Under dry conditions, apply a compatible corrosion preventive or sealant, within 24 hours of assembly of the bond materials. Under conditions exceeding 60% humidity, seal the bond with a compatible corrosion preventive or sealant within 1 hour of joining.

4.1.1.8.1 Paint

If a paint finish is required on the final assembly, the bond shall be sealed with the recommended finish. Care shall be taken to assure that all means by which moisture or other contaminants

enter the bond are sealed. A waterproof type of paint or primer shall be used if the recommended finish is not waterproof.

4.1.1.8.2 Compression Bonds in Protected Areas

Sealing is not required for compression bonds between copper conductors or between compatible aluminum alloys located in readily accessible areas that are not exposed to moisture, corrosive fumes, or excessive dust.

4.1.1.8.3 Corrosion Protection

All exterior and interior bonds exposed to moisture or high humidity shall be protected against corrosion. All interior bonds made between dissimilar metals shall be protected against corrosion in accordance with paragraph 4.1.1.2.3 and paragraph 4.1.1.2.4.1. All exothermic welds shall be cleaned of all residual slag. Protection shall be provided by a moisture proof paint conforming to the requirements of FAA-STD-012 or shall be sealed with a silicone or petroleum-based sealant to prevent moisture from reaching the bond area. Bonds protected by conductive finishes (alodine, iridite, et. al.) shall not require painting to meet the requirements of this standard.

4.1.1.9 Bonding across Shock Mounts

Bonding straps installed across shock mounts or other suspension or support devices shall not impede the performance of the mounting device. They shall be capable of withstanding the anticipated motion and vibration requirements without suffering metal fatigue or other failures.

4.1.1.10 Enclosure Bonding

Directly bond subassemblies and equipment at the areas of physical contact with the mounting surface.

4.1.1.11 Subassemblies

Utilize the maximum possible contact area when bonding subassemblies to the chassis. All feed throughs, filters, and connectors shall be bonded around the periphery to the subassembly enclosure to maintain shield effectiveness. Covers shall exhibit intimate contact around their periphery, and contact shall be achieved and maintained through the use of closely spaced screws or bolts, or the use of resilient conductive gaskets, or both. Note: COTS equipment should be treated as a sealed unit for the purposes of this requirement.

4.1.1.12 Equipment

The chassis or case of equipment shall be directly bonded to the rack, frame, or cabinet in which it is mounted. Clean all flange surfaces and the contact surface on the supporting element of all paint or other insulating substances in accordance with the requirements of paragraph 4.1.1.7. Fasteners shall maintain sufficient pressure to assure adequate surface contact to meet the bond resistance requirements in paragraph 4.1.1.1. Captive nuts and sheet metal screws shall not be used for fasteners. If equipment must remain operational when partially or completely withdrawn from its mounted position, the bond shall be maintained by a moving area of contact or by the use of a flexible bonding strap. Mechanical designs shall employ direct bonding, without straps, whenever feasible.

4.1.1.13 Connector Mounting

All metal or metallized connectors shall be mounted so that electrical contact is maintained between the connector body and the panel to which it is mounted. Bonding shall be accomplished completely around the periphery of the flange of the connector. Both the flange surface and the mating area on the panel shall be cleaned in accordance with paragraph 4.1.1.7. All nonconductive material shall be removed from the panel as illustrated in Figure II. After mounting of the connector, the exposed area of the panel shall be repainted or otherwise protected from corrosion in accordance with paragraph 4.1.1.8.

4.1.1.14 Shield Terminations

Cable shields shall be terminated in the manner specified by paragraphs 4.1.2.3.2 and 4.1.2.3.3. Shields of axial cables shall be fastened tightly to the cable connector shell with a compression fitting or soldered connection. The cable shall be able to withstand the anticipated use without becoming noisy or suffering a degradation in shielding efficiency. Axial connectors shall be of a material that is corrosion resistant in keeping with requirements of FAA-G-2100. Low frequency shields shall be soldered in place or, if solderless terminals are used, the compressed fitting shall afford maximum contact between the shield and the terminal sleeve. Shield pigtails shall extend less than 1 inch from the point of breakaway from the center conductors of the cable.

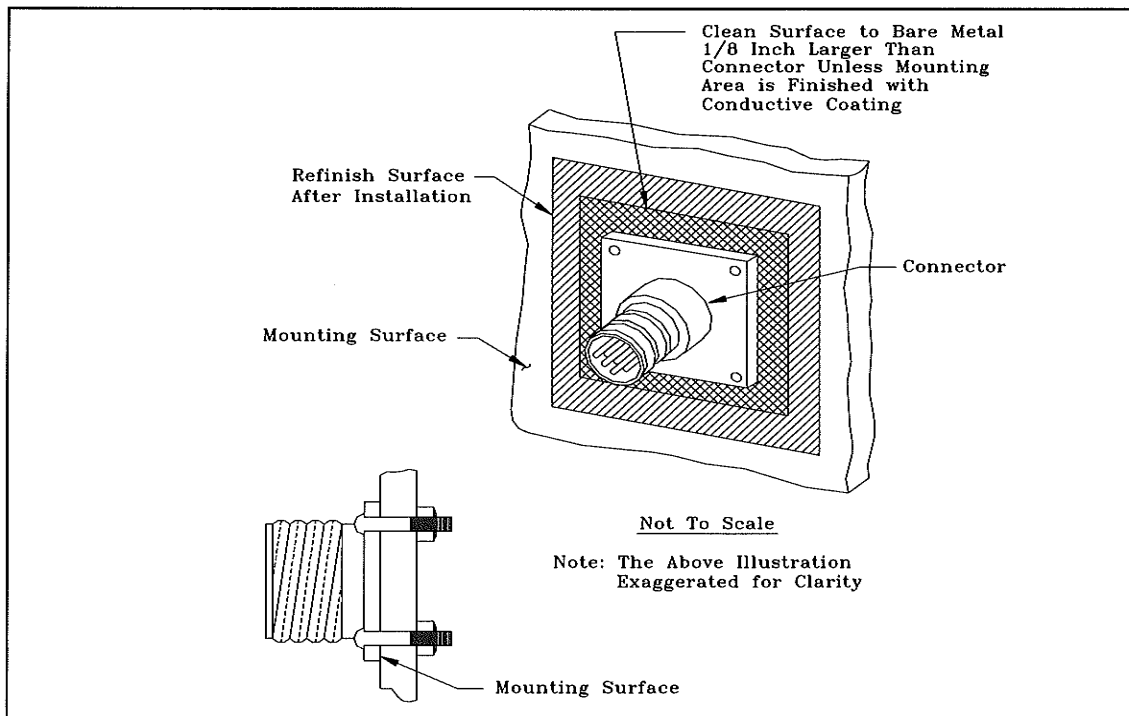

Figure II. Bonding of Connectors to Mounting Surface

4.1.1.15 RF Gaskets

Conductive gaskets shall be made of corrosion resistant material, shall offer sufficient conductivity to meet the resistance requirements of paragraph 4.1.1.1, and shall possess adequate

strength, resiliency, and hardness to maintain the shielding effectiveness of the bond. The surfaces of contact with the gasket shall be smooth and free of insulating films, corrosion, moisture, and paint. The gasket shall be firmly affixed to one of the bond surfaces by screws, conductive cement, or other means that do not interfere with the effectiveness of the gasket; or a milled slot shall be provided that prevents lateral movement or dislodging of the gasket when the bond is disassembled. Gaskets shall be a minimum of $\frac{1}{8}$ inch wide. The gasket as well as the contact surfaces shall be protected from corrosion.

4.1.2 Shielding Requirements

4.1.2.1 Design

The facility design and construction shall incorporate both protective shields to attenuate radiated signals, and separation of equipment and conductors to minimize the coupling of interference. The equipment design shall incorporate component compartments and overall shields as necessary to meet the electromagnetic susceptibility and emission requirements of MIL-STD-461 as required by NAS-SS-1000 and FAA-G-2100. In addition, the design shall provide the shields necessary to protect personnel.

4.1.2.2 Facility Shielding

Shielding of facility buildings, shelters or equipment spaces shall be provided when other facility or environmental sources of radiation are of sufficient magnitude to degrade the operation and performance of electronic equipment or system. Where rebar or a rudimentary Faraday cage exists, it shall be connected to the EES with a minimum 2 AWG copper conductor that is applied via an exothermic weld or a hydraulically crimped termination.

4.1.2.3 Conductor and Cable Shielding

Conductor and cable shielding shall comply with the following sub-paragraphs:

4.1.2.3.1 Signal Lines and Cables

Cables consisting of multiple twisted pairs shall have individual shields for each twisted pair.. The shields shall be isolated from each other. Cables with an overall shield shall have the shield insulated and isolated from the individual shields..

4.1.2.3.2 Termination of Individual Shields

Shields of pairs of conductors, line shields, and the shield of cables containing unshielded conductors shall be terminated in accordance with the following:

- (a) Shields shall be terminated to ensure correct equipment operation.
- (b) Shield terminations shall employ minimum length pigtailed between the shield and the connection to the bonding halo or ferrule ring and between the halo or ferrule ring and the shield pin on the connector. The unshielded length of a signal line shall not exceed 1 inch (25 mm) with not more than $\frac{1}{2}$ inch (13 mm) of exposed length as the desired goal.
- (c) Shields, individually and collectively, shall be isolated from overall shields of cable bundles and from electronic equipment cases, racks, cabinets, junction boxes, conduit, cable trays, and elements of the electronic multipoint ground system. Except for one interconnection, individual shields shall be isolated from each other. This isolation shall be maintained in

junction boxes, patch panels and distribution boxes throughout the cable run. When a signal line is interrupted such as in a junction box, the shield shall be carried through. The length of unshielded conductors shall not exceed 1 inch (25 mm). To meet this requirement, the length of shield pigtail longer than 1 inch shall be allowed but shall be the minimum required.

- (d) Circuits and chassis shall be designed to minimize the distance from the connector or terminal strip to the point of attachment of the shield grounding conductor to the electronic signal reference. The size of the wire used to extend the shield to the circuit reference shall be as large as practical but shall not be less than 16 AWG or the maximum wire size that will fit the connector pin. A common shield ground wire for input and output signals, for both high level and low level signals, for signal lines and power conductors, or for electronic signal lines and control lines shall not be used.
- (e) Nothing in this requirement shall preclude the extension of the shields through the connector or past the terminal strip to individual circuits or chassis if required to minimize unwanted coupling inside the electronic equipment. Where extensions of this type are necessary, overall cable or bundle shields grounded in accordance with paragraph 4.1.2.3.3 shall be provided.

4.1.2.3.3 Termination of Overall Shields

Cables that have an overall shield over individually shielded pairs shall have the overall shield grounded at each end unless otherwise required by the equipment. Grounding through an SPD is permissible if grounding both ends of the conductors degrades system performance. The drain wire if present shall be grounded the same as the shield.

- (a) Cable shields terminated to connectors shall be bonded to the connector shell as shown in Figure IIIa or Figure IIIb. The shield shall be carefully cleaned to remove dirt, moisture, and corrosion products. The connector securing clamp shall be carefully tightened to assure that a low resistance bond to the connector shell is achieved completely around the circumference of the cable shield. The bond shall be protected against corrosion in accordance with paragraph 4.1.1.8. The panel-mounted part of the connector shall be bonded to the mounting surface in accordance with paragraph 4.1.1.13.
- (b) Where the cable continuity is interrupted, such as in a junction box, the shield shall be carried through and grounded at the box. The length of unshielded conductors shall not exceed 1 inch (25 mm). If necessary, the shield pigtail shall be allowed longer than 1 inch to reach ground but shall be as short as possible.
- (c) Cables which penetrate walls or panels of cases or enclosures without the use of connectors shall have their shields bonded to the penetrated surface in the manner shown in Figure IIIc. Overall shields shall be terminated to the outer surface of cases to the maximum extent possible.
- (d) Grounding of overall shields to terminal strips shall be as shown in Figure IV.

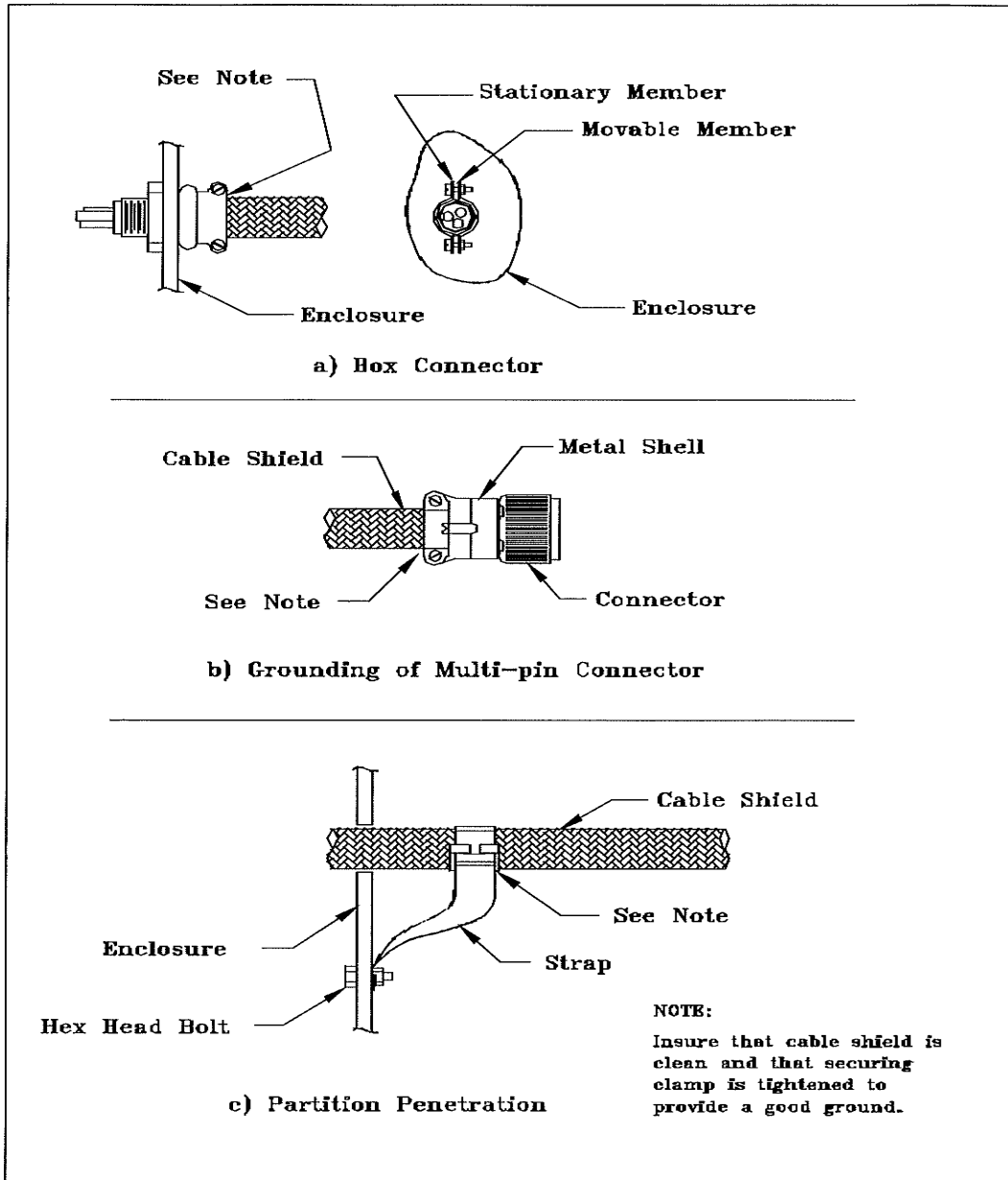

Figure III. Grounding of Overall Cable Shields to Connectors and Penetrating Walls

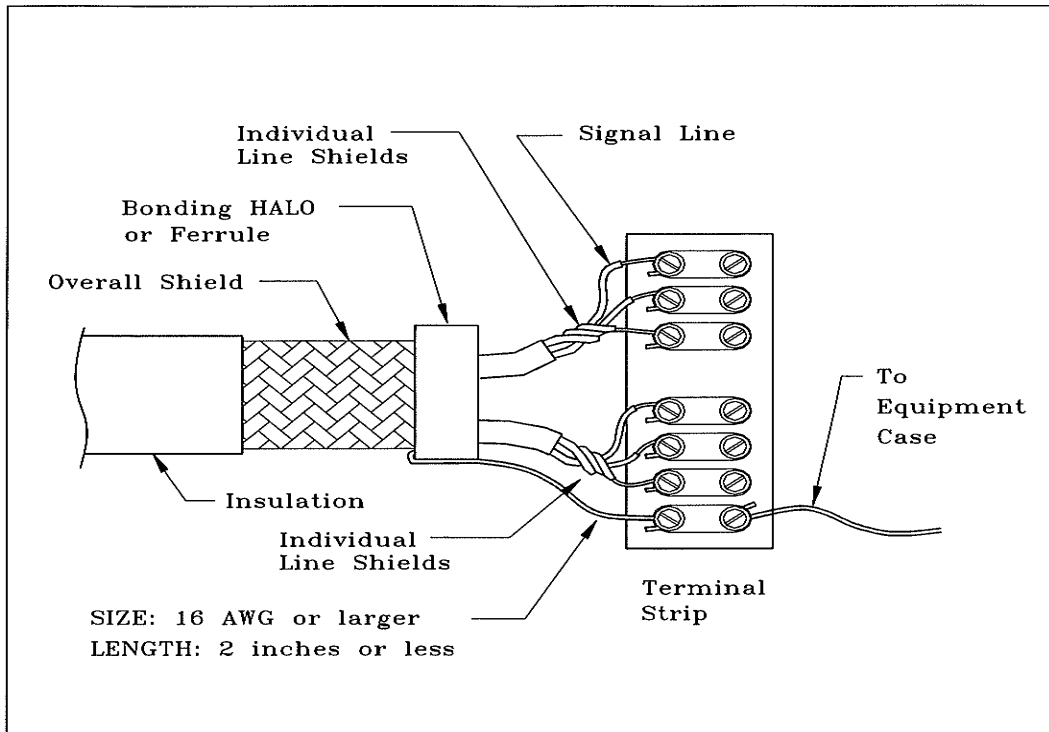

Figure IV. Grounding of Overall Cable Shield to Terminal Strip

4.1.2.4 Electromagnetic Environment Control

Shielding shall be integrated with other basic interference control measures such as filtering, wire routing, cable and circuit layout, signal processing, spectrum control, and frequency assignment to achieve the highest operational reliability of the equipment. Implementation procedures necessary to achieve the required filtering and shielding shall be detailed in the control plan described in paragraph 4.1.4.2 to include material requirements, shield configurations, placement and installation limitations, gasket utilization, filter integration, aperture control, bonding and grounding requirements, and wire routing and circuit layout constraints.

4.1.2.4.1 Space Separation

The design and layout of facilities shall physically separate electronic equipment and conductors that produce interference from equipment and conductors that are susceptible to interference. The minimum separation distance between power and signal cables shall be in accordance with Table III.

4.1.2.4.2 Wire and Cable Routing

The routing and layout of wires, conductors and cables shall be performed in a manner that does not jeopardize the integrity of the equipment shield. Signals with power level differences of greater than 20dB shall be routed as far apart as feasible. AC power conductors and control lines shall be routed away from sensitive digital or other susceptible circuits. Shielded cables shall be

used where needed to prevent emissions and/or to provide shielding. Cable shields shall be grounded in accordance with the requirements of paragraphs 4.1.2.3.2 and 4.1.2.3.3

Table III. Minimum Separation Distance Between Signal and Power Conductors.

Condition	Circuit Power Level		
	< 2 kVA	2-5 kVA	> 5 kVA
Unshielded power lines or electrical equipment in proximity to signal conductors in open cable tray or nonmetal raceway.	5 in. (127 mm)	12 in. (305 mm)	24 in. (610 mm)
Unshielded power lines or electrical equipment in proximity to signal conductors in a grounded metal raceway.	2.5 in. (64 mm)	6 in. (152 mm)	12 in. (305 mm)
Power lines enclosed in a metal raceway (or equivalent shielding) in proximity to signal conductors in a metal raceway.	-	3 in. (76 mm)	6 in. (152 mm)

4.1.2.4.3 Gaskets

Conductive gaskets conforming to paragraph 4.1.1.15 shall be utilized at joints, seams, access covers, removable partitions, and other shield discontinuities to the extent necessary to provide interference-free operation of the equipment under normal use and environmental conditions. Finger stock used on doors, covers, or other closures subject to frequent openings shall be installed in a manner that permits easy cleaning and repair.

4.1.2.4.4 Filter Integration

Filters on power, control, and signal lines shall be installed in a manner that maintains the integrity of the shield. AC power filters shall be completely shielded with the filter case grounded in accordance with paragraph 4.3.4.4. Filters for control and signal lines shall be placed as close as possible to the point of penetration of the case to avoid long, unprotected paths inside the equipment.

4.1.2.4.5 Bonding and Grounding of Compartment Shields

All shields shall be grounded. Bonding shall be accomplished in accordance with paragraph 4.1.1.

4.1.3 Electrostatic Discharge (ESD) Requirements

Modern electronic and electronically controlled electrical equipment is susceptible to damage from Electrostatic Discharge (ESD). The requirements of this section are designed to reduce the frequency and minimize the effects of ESD events. All electronic circuitry that contains miniaturized or solid-state components shall be considered ESD susceptible.

4.1.3.1 ESD Sensitivity Classification

Classification of items as ESD sensitive shall be in accordance with the Human Body Model testing procedures and requirements of ANSI/ESD STM5.1. Electronic parts, components, and assemblies shall be classified as either sensitive or supersensitive. Items that will fail from ESD at 1000 to 16000 Volts shall be classified as ESD sensitive. Those items that will fail below 1000 Volts shall be classified as supersensitive. Any exceptions to this guidance shall be through the OPR of this document. Devices with a sensitivity of less than +/- 200 Volts require additional ESD protection measures than those specified in this standard. ESD susceptible items shall not be exposed to an electrostatic field (E-field) greater than 100 Volts/meter or brought closer than 24" to known static generators or non-essential insulative materials.

4.1.3.2 ESD Protection Requirements

All NAS electrical and electronic equipment, subassemblies, and components subject to damage from exposure to electrostatic fields or electrostatic discharge (ESD) shall be protected in accordance with the protection requirements herein. ESD controlled areas shall be provided for all operations, storage, repair, and maintenance spaces used for electrical and electronic equipment or subassemblies that are subject to damage from static electricity or ESD.

4.1.3.3 Classification of Materials

4.1.3.3.1 General

Most materials and products that are used to control and prevent ESD are classified by their resistive properties as conductive or static dissipative. Antistatic materials are an exception to this and are classified by their propensity to not generate static electricity from triboelectric charging. Any material used for construction of ESD protected areas (with the exception of antistatic materials) shall meet the resistive properties specified for type and use of the material. Materials that will tribocharge to greater than +/- 200 Volts (EIA-625), if the material were to contact and separate from itself or from other materials, shall not be used in ESD controlled areas.

4.1.3.3.2 Static Conductive Materials

Those materials with a surface resistivity less than 1.0×10^5 ohms/square when tested per ANSI/ESD S11.11 shall be considered conductive. Conductive ESD control materials shall not be used for ESD control work surfaces, tabletop mats, floor mats, flooring, or carpeting where the threat of personnel contact with energized electrical or electronic equipment exists. Conductive ESD control materials are not to be used in any other application where their use could result in electromagnetic interference (EMI) or radio frequency interference (RFI) that would be created by rapid, high voltage ESD spark discharges. Any exceptions to this guidance shall be through the OPR of this document.

4.1.3.3.3 Electrostatic Shielding Materials

Electrostatic shielding materials are a subset of conductive materials with a surface resistance equal to or less than 1.0×10^3 ohms when tested per ANSI/ESD S11.11. Electrostatic shielding materials shall be allowed as barriers for protection of ESD sensitive items from electrostatic fields where required.

4.1.3.3.4 Electromagnetic Shielding Materials

Electromagnetic shielding materials with highly conductive surfaces (< 10 ohms) or specifically designed composite materials that absorb and reflect electromagnetic radiation over a broad range of frequencies shall also be allowed as barriers where required to protect ESD sensitive items from electromagnetic fields.

4.1.3.3.5 Static Dissipative Materials

Those materials with a surface resistivity greater than 1.0×10^5 ohms/square but less than or equal to 1.0×10^{12} ohms/square when tested per ANSI/ESD S11.11 are classified as static dissipative materials. Static dissipative materials with a surface resistance less than or equal to 1.0×10^9 ohms shall be used to provide controlled bleed-off of accumulated static charges in ESD controlled areas. Static dissipative materials with a surface resistance of greater than 1.0×10^9 ohms shall not be used for applications where controlled bleed-off of accumulated static charges is essential. Any exception to this guidance shall be through the OPR of this document.

4.1.3.3.6 Antistatic Materials

Any material that inhibits or has a low propensity to generate static electricity from triboelectric charging shall be considered antistatic. Antistatic ESD control items and materials used for construction of ESD controlled areas in new or renovated facilities shall not tribocharge to greater than ± 200 Volts when being used for their intended application. Antistatic materials with a surface resistance greater than 1×10^9 ohms shall not be used for ESD protective work surfaces, tabletop mats, floor mats, flooring, and carpeting when charge dissipation is the primary consideration. If the surface resistance (R_{tt}) of an antistatic material is greater than 10^{12} ohms it shall normally be considered to be too resistive for use in ESD controlled areas. Use of antistatic items and materials that utilize hygroscopic surfactants that depend on ambient humidity to promote absorption of water shall be limited. Only antistatic materials that are intrinsically antistatic and will retain their antistatic properties shall be used in ESD controlled areas. Exceptions to this guidance shall be through the OPR of this document.

4.1.3.3.7 Static-Generative Materials, Non-Conductors, and Insulators

Materials having a surface resistance greater than 1.0×10^{12} ohms (ANSI/ESD S11.11) shall be considered to be insulators and a possible source of triboelectric charging. These include common plastics, Plexiglas, Styrofoam, Teflon, nylon, rubber, untreated polyethylene, and polyurethane. Their use shall be minimized where ESD sensitive items are located.

4.1.3.4 Protection of ESD Susceptible and Sensitive Items

4.1.3.4.1 Static Protected Zone

A static protected zone shall be a volume or area where unprotected ESD sensitive items will be safe from direct contact with electrostatic potentials greater than ± 200 volts, electrostatic fields greater than 100 volts/meter, or radiated electromagnetic interference and radio frequency interference produced by rapid, high voltage ESD spark discharges. Static protected zones shall be incorporated into the construction of ESD special protection areas, ESD protected workstations, and ESD protected storage areas.

4.1.3.4.2 ESD Special Protection Areas

Special protection areas shall be designated areas that require extraordinary ESD control measures to accomplish the following:

- (a) Minimize triboelectric charging.
- (b) Control bleed-off and dissipation of accumulated static charges.
- (c) Neutralize charges.
- (d) Minimize the effects of E-Fields, H-Fields, and EMI and RFI from ESD spark discharges.

Areas within a facility that shall be designated as ESD special protection areas are:

- (a) Air traffic operations areas (e.g., tower cab, TRACON, ARTCC control rooms, AFSS, etc.).
- (b) Electronic equipment rooms.
- (c) Storage areas for ESD susceptible components, subassemblies, circuit cards, etc.
- (d) Areas that contain personal computers and Local Area Networks (LANs) that are connected to or interface directly with NAS electronic equipment.
- (e) All other locations where jacks, plug in connectors or interfaces of ESD sensitive electronic equipment are exposed and vulnerable to damage from ESD by direct human contact shall also be designated as ESD special protection areas.

4.1.3.4.3 ESD Controls Required for ESD Special Protection Areas

The following minimum ESD control measures shall be implemented in all areas designated as ESD special protection areas:

4.1.3.4.3.1 ESD Groundable Point (GP)

Each ESD control material, surface, or item used in an ESD controlled area shall have a designated groundable point (GP) to provide ease of connection to the nearest Signal Reference Structure (SRS).

4.1.3.4.3.2 Grounded Static Dissipative Surfaces

All work surfaces which include work surface laminates, paints and sealers, writing surfaces, table tops, consoles, workbenches, and table top mats shall be static dissipative and connected to any SRS in the area served – except to a single point ground system. The point-to-point resistance and surface to ground resistance of static dissipative work surfaces shall be greater than 1.0×10^6 ohms and less than 1.0×10^9 ohms (ANSI/ESD S4.1).

4.1.3.4.3.3 Limiting the Use of Non-ESD Control Materials

Materials that will tribocharge (e.g., generate electrostatic potentials by contact and separation with themselves or other materials) shall not be used for construction in ESD special protection areas. Insulative materials and any other non-essential triboelectric charge generators that generate potentials in excess of +/- 200 Volts shall not be permitted within 24 inches of ESD special protection areas.

4.1.3.4.3.4 Static Dissipative Chairs

Chairs (e.g., seating) provided for ESD special protection areas shall incorporate a continuous path between all chair elements (e.g., cushion and arm rests) to the ground points of greater than

1.0×10^5 ohms to less than 1.0×10^9 ohms. The ground points for ESD chairs are static dissipative or conductive casters that provide electrical continuity from all elements of the chair to ESD control carpeting, tile, or floor mats that are properly bonded to any SRS – except to a single point ground system. ESD control chairs must be tested and meet the requirements of ANSI/ESD STM12.1.

4.1.3.4.3.5 Static Dissipative ESD Control Floor Coverings

Static dissipative ESD control floor coverings shall include static dissipative tile, carpeting, static limiting floor finishes, and floor mats. Floor coverings in ESD special protection areas shall have a point-to-point resistance and surface-to-ground resistance of greater than 1.0×10^6 ohms and less than 1.0×10^9 ohms (ANSI/ESD S7.1). These floor coverings shall be bonded to any SRS in the area served in accordance with paragraphs 4.1.3.4.3.1 and 4.1.3.4.8 – except to a single point ground system. In circumstances involving extremely static sensitive equipment a static conductive floor covering with a lower resistance limit of 2.5×10^4 ohms (UL779) shall be implemented when it is part of a designed approach for ESD control for the equipment approved by the OPR of this document. This designed approach shall include all steps required to produce an electrically safe working environment.

4.1.3.4.3.6 Relative Humidity Control

Relative humidity in ESD special protection areas shall be maintained within the range of 40 to 60%.

4.1.3.4.4 ESD Signs, Labels, Cautions, and Warnings

ESD warning signs that include ESD sensitive device warning symbols with appropriate cautions and warnings shall be posted in ESD special protection areas and all other ESD controlled areas. Exterior cabinets of ESD sensitive electronic equipment shall also be marked or labeled with an ESD sensitive device symbol with a warning that is visible from at least 3 feet. Any signs or labels shall be consistent with the requirements of ANSI/ESD S8.1.

4.1.3.4.5 ESD Protected Workstations

These workstations are for the maintenance and repair of ESD sensitive equipment.

4.1.3.4.5.1 ESD Protected Workstation Minimum Requirements

All ESD control items at an ESD protected workstation shall be connected to a common groundable point, i.e., ESD ground, that is connected to any SRS in the area served – except to a single point ground system. ESD protected workstations shall be free of all non-essential static charge generators; and provide a means of personnel grounding. They shall have a grounded static dissipative work surface, and grounded static dissipative ESD control floor or mat. Storage containers provided at ESD protected workstations shall provide ESD protection and shall also be connected to the ESD ground. All outlets at ESD protected workstations shall be protected with ground fault circuit interruption (GFCI) capability to minimize danger to grounded personnel from electrical shock.

4.1.3.4.5.2 Use of Ionization

Selective use of bench top or area ionizers shall be allowed at ESD protected workstations if static generative items (e.g., insulators) are deemed essential and cannot be removed from ESD

protected workstation areas or if grounding of mobile personnel would be cumbersome or create a safety hazard.

4.1.3.4.5.3 Identification of ESD Protected Workstations

The boundaries of all ESD protected workstations shall be clearly defined. The boundaries of ESD protected workstations shall extend a minimum of 24 inches beyond where ESD sensitive items will be located and will be marked with yellow tape. ESD warning signs that are yellow with black markings and lettering shall be posted that will be visible to anyone entering these areas. Signs shall include an ESD sensitive electronic device warning symbol and appropriate warnings and cautions.

4.1.3.4.6 ESD Protective Storage Areas

4.1.3.4.6.1 Shelves, Bins, and Drawers

Shelves, bins, and drawers shall be static dissipative and electrically continuous with the support structure of the storage shelves, bins, or container.

4.1.3.4.6.2 Grounding

The storage container metal support structure shall have a groundable point (GP) that shall be connected to the nearest SRS – except to a single point ground system . The resistance from the ground point of storage containers, shelving, cabinets, and bins used to store ESD sensitive items to the nearest SRS shall be less than one ohm.

4.1.3.4.6.3 Personnel Grounding

Wrist straps shall be equipped with one megohm or greater series resistance to protect personnel. Standard 0.157 inch banana jacks for personnel grounding wrist straps shall be connected to the ESD ground or directly to any SRS in the area served – except to a single point ground system. The resistance from a banana jack to a ground point and/or to the nearest SRS – except to a single point ground system shall be less than one ohm.

4.1.3.4.6.4 Materials Prohibited in ESD Protective Storage Areas

Static generative (e.g., insulative) materials shall not be used for construction in any areas where ESD sensitive items will be stored. All materials that can generate potentials greater than +/- 200 Volts shall be a minimum of 24 inches from ESD protected storage areas.

4.1.3.4.6.5 Resistance to ESD Ground for Shelves, Drawers, and Bins

All surfaces and drawers of the storage media provided shall be made with static dissipative materials and meet the requirements and be tested the same as work surfaces (ANSI/ESD S4.1). The surface-to-surface resistance (R_{tt}) and surface-to-ground resistance (R_{tg}) from the shelves, bins, and drawers of storage containers that will be used to store unprotected ESD sensitive items shall be greater than 1.0×10^6 ohms and less than 1.0×10^9 ohms (ESD ADV53.1).

4.1.3.4.6.6 Identification of ESD Protective Storage Areas

The boundaries of all ESD protective storage areas shall be clearly defined. Boundaries of ESD protective storage areas shall extend a minimum of 24 inches beyond where ESD sensitive items will be located and will be marked with yellow tape. ESD warning signs that are yellow with

black markings and lettering shall be posted that will be visible to anyone entering these areas. Signs shall include an ESD sensitive electronic device warning symbol and appropriate warnings and cautions.

4.1.3.4.7 Hard and Soft Grounds

4.1.3.4.7.1 Hard Grounds

Any item, material, or product that is a part of the ESD control system that is intentionally or unintentionally connected to an ESD ground, or directly to any SRS in the area served – except to a single point ground system – shall be considered to be hard grounded. Unless specified otherwise or justified by the OPR for this document, ESD control worksurfaces, cabinets, flooring, carpeting, test equipment, and any other items used for ESD control shall be hard grounded.

4.1.3.4.7.2 Soft Grounds

A soft ground is an intentional connection to ground through a series current limiting resistor. Soft grounding shall only be used in personnel grounding skin contact devices such as wrist straps, leg or ankle straps, conductive shoes, and heel or toe grounders. The nominal resistance of the resistor used for soft grounding of personnel shall be greater than 1.0×10^6 ohms unless otherwise specified by the OPR for this document. All other elements of the ESD control system shall be hard grounded.

4.1.3.4.8 ESD Control Flooring and Floor Coverings

All ESD control floors and floor coverings shall have a point to point resistance and a surface to ground resistance of greater than 1.0×10^6 ohms and less than 1.0×10^9 ohms (ESD STM7.1). ESD control flooring and floor coverings include vinyl tile, vinyl sheet, carpet, carpet tile, carpet tile with positioning buttons and others but not to include applied coatings.

These control floors and floor coverings shall be installed, grounded, and initially tested only by trained installers. A representative ten-foot-square section of the floor system shall be tested and the results approved and accepted by FAA personnel, prior to installation of the full floor system.

ESD control floors and floor coverings shall be bonded to the nearest SRS at a minimum of four locations. The connections and method shall be recommended by the floor manufacturer and approved by the OPR. These connections shall utilize copper: strip, foil, conductive fabric ribbon, or stranded wire. Electrical contact shall be made with the underside of the floor material or connections may be embedded in the conductive permanent or releasable adhesive used to lay the floor. The ESD control flooring shall not be bonded to any single point ground system.

4.1.3.4.8.1 Surface Resistance (R_{tt})

Surface resistance (R_{tt} - Resistance top-to-top or surface-to-surface) of ESD control floors, carpets or floor mats shall be greater than 1.0×10^6 ohms and less than 1.0×10^9 ohms (ANSI/ESD S7.1). A minimum of five readings shall be taken at different locations on the floor surface and averaged together for each 500 square feet (or fraction thereof) of floor surface. These readings shall be recorded in the FRDF.

4.1.3.4.8.2 Resistance Surface-to-Ground (R_{tg})

Resistance from the floor surface to ground (R_{tg} - Resistance top-to-ground) of ESD control floors, carpets or floor mats shall be greater than 1.0×10^6 ohms and less than 1.0×10^9 ohms (ANSI/ESD S7.1). A minimum of five readings shall be taken at different locations on the floor surface and averaged together for each 500 square feet (or fraction thereof) of floor surface. These readings shall be recorded in the FRDF.

4.1.3.4.8.3 Triboelectric Charging Limitation

ESD control floors, carpets, or floor mats shall limit and control generation and accumulation of static charges to less than +/- 200 Volts in ESD controlled area.

4.1.3.4.9 ESD Requirements for Raised Floors

4.1.3.4.9.1 Resistance from Carpet Surface to Pedestal Understructure

Carpet tiles shall have a resistance from the carpeted surface of the raised floor to the pedestal greater than 1.0×10^6 ohms and less than 1.0×10^9 ohms.

4.1.3.4.9.2 Panel to Floor Understructure Resistance

Panel-to-understructure (metal-to-metal) contact resistances between individual raised floor panels and the floor understructure shall be 10 ohms or less.

4.1.3.4.9.3 Carpet Tile Installation on Raised Floor Panels

Install individual carpet tiles on raised floor panels with either permanent or releasable conductive adhesive depending on the application.

4.1.3.4.9.4 Grounding

There shall be a minimum of four connections per 1,000 square feet of installed ESD control carpeting from the carpeting undersurface and conductive adhesive to the raised floor panel understructure. The Connections and method shall be in accordance with paragraph 4.1.3.4.8.

4.1.3.4.10 ESD Protective Worksurfaces

Static dissipative materials or electrostatic dissipative laminates shall be used to cover all worksurfaces, consoles, workbenches, and writing surfaces in areas that contain ESD sensitive equipment and in all areas designated as ESD special protection areas, static-safe zones, and ESD protected areas.

4.1.3.4.10.1 Requirements for ESD Protective Worksurfaces

Static dissipative worksurfaces shall be provided for new or upgrade facilities unless otherwise specified. Permanent static dissipative worksurfaces shall be connected to any SRS in the area served – except to a single point ground system. Permanent ESD protective static dissipative worksurfaces shall have a resistance greater than 1.0×10^6 ohms point-to-point (R_{tt}) and less than 1.0×10^9 ohms (ANSI/ESD S4.1). Permanent ESD protective worksurfaces shall have a resistance from their surface to the groundable point (R_{tg}) greater than 1.0×10^6 ohms and less than 1.0×10^9 ohms (ANSI/ESD S4.1).

4.1.3.4.10.1.1 Worksurface Types

ESD protective worksurfaces used for FAA workstations shall meet the requirements of MIL-PRF-87893 Performance Specification, Workstation, Electrostatic Discharge Control and MIL-W-87893 Military Specification, Workstation, Electrostatic Discharge (ESD) Control.

4.1.3.4.10.1.2 Type I Worksurface - Hard

Type I worksurfaces shall be constructed of rigid static dissipative materials of any color having an average Shore D hardness in excess of 90. Two male or female 0.395 inch ground snap (female) or stud (male) fasteners shall be installed on both corners on one of the longest sides of the worksurface to accommodate the male or female snap or stud fastener of the common point grounding cord. The locations of the two snaps or studs shall be 2 inches from each corner.

4.1.3.4.10.1.3 Type II Worksurface - Soft

Type II worksurfaces shall be constructed of cushioned static dissipative materials of any color having an average Shore A (ATSM D2240) hardness in excess of 45 and less than 85. Two male or female 0.395 inch ground snap (female) or stud (male) fasteners shall be installed on both corners on one of the longest sides of the worksurface to accommodate the male or female snap or stud fastener of the common point grounding cord. The locations of the two male or female snaps or studs shall be 2 inches from each corner. No low-density open-cell materials shall be used for Type II worksurfaces.

4.1.3.4.10.2 Static Dissipative Laminates

High pressure, multi-layer static dissipative laminates shall be used to cover surfaces such as plywood, fiber board, particle board, bench tops, counter tops, and consoles in ESD controlled areas and special protection areas. Laminates shall include a buried conductive layer to provide for ease of grounding using a through bolted pressure type ESD grounding terminal.

4.1.3.4.10.3 Grounding of Laminated Surfaces

The resistance across the surface (R_{tt}) of the static dissipative laminate shall be greater than 1.0×10^6 ohms and less than 1.0×10^9 ohms. The resistance from the surface of the laminate to ground (R_{tg}) shall be greater than 1.0×10^6 ohms and less than 1.0×10^9 ohms (ANSI/ESD S4.1). A minimum of five readings of each shall be taken and averaged together. These readings and averages shall be recorded in the FRDF.

4.1.3.4.11 Static Dissipative Coatings

Permanent clear or colored static dissipative coatings used in ESD controlled areas, including all painted surfaces, shall have a point to point resistance greater than 1.0×10^6 ohms and less than 1.0×10^9 ohms.

4.1.4 Electromagnetic Compatibility Requirements

4.1.4.1 General

A comprehensive plan for the application of various sections of this document is required to assure the compatible operation of equipment in complex systems. Additional considerations of this section shall be implemented to reduce susceptibility and emissions of equipment.

4.1.4.2 Requirements

The emission and susceptibility limits contained in MIL-STD-461 shall be applied unless otherwise specified. An EMI Control and Test Plan shall be developed in accordance with MIL-HDBK-237 to assure compliance with the applicable requirements. The plan shall include a verification matrix to track the satisfaction of requirement by test, analysis or inspection. .

4.1.4.3 Approval

Control Plans and Test Plans shall be submitted to the OPR of this document for approval.

4.2 Facility Requirements

4.2.1 Passive Transient Protection Requirements

All metallic conduit, conductors and cables in NAS operational facilities are subject to currents induced by nearby lightning strikes. These induced effects can adversely affect the operation of sensitive electronic equipment.

4.2.1.1 Existing Metallic Conduit, Conductors and Cables

Unless the facility manager disapproves the removal, all unused conduits, conductors and cables shall be removed. The facility manager shall be consulted to validate the decision to remove any metallic conduit, conductors or cables prior to acting. If they are to remain, the following actions shall be accomplished to minimize the voltage differential between ends:

- (a) Metallic conduits shall be bonded to adjacent grounded metalwork at both ends.
- (b) Unused conductors bonded to adjacent grounded metalwork at both ends.
- (c) Unused cables shall have conductors and shields bonded to adjacent grounded metalwork at both ends.

If not direct connected the above bonding shall utilize a 6AWG minimum pigtail no longer than 18 inches. Multiple conductors shall be grouped together and bonded to the adjacent metalwork directly or via a single pigtail.

Unused conductors of a structured cable system installed for spares purposes with vertical risers of no more than fifty feet and of circuit length totaling no more than three hundred feet are exempted from this requirement if they do not pass between facilities. Where circulating currents are present, installation of a SPD at one end of the cable shall be allowed for this requirement..

The OPR of this document should be contacted for additional information.

4.2.1.2 Electromagnetic Shielding for Lines, Conductors and Cables

4.2.1.2.1 Facility Entrance Conduit

All lines, conductors and cables, both overhead and buried, shall enter the facility through a minimum of 10 feet of ferrous conduit (RGS). Conduit routed by other than a direct route shall be allowed to achieve this 10-foot requirement. All entrance conduits shall be bonded to the EES with a bare copper stranded conductor, 2 AWG minimum. This entrance conduit, if buried, shall extend 5 feet beyond the earth electrode system.

4.2.1.2.2 Buried External Power Cables and Conductors

Buried external power cables and conductors shall have magnetic shielding to prevent coupling of damaging transient currents, from man made and lightning sources. This shielding can only be provided by a ferrous metal. This may be in the form of a sheath, ferrous armor or ferrous conduit (RGS). Specification details of this type of cable and potential sources are available from the OPR and the LPGBS web page. Ferrous armor cable has been shown to be extremely cost effective when compared to ferrous conduit and presents a marginal increase in cost over unarmored cable. Cables may be installed in metallic or nonmetallic conduit where permitted by the NEC. When a conduit is not used cables shall be identified for direct earth burial (DEB).

For portions of buried external power cables and conductors greater than 300 feet cable length from the facility ferrous shielding is recommended but not required. Facility entrance surge protection shall be provided that fully complies with paragraph 4.2.2 and all sub paragraphs.

4.2.1.2.3 Buried Landlines

The preferred type of buried landline that represents best engineering practice is fiber optic type. Fiber optic cable does not require electromagnetic shielding and is exempt from these requirements. Metallic buried landlines that carry NAS Critical, Essential or Mission Support Services to a facility shall have a ferrous shield or be enclosed in ferrous conduit (RGS).

For portions of these buried landlines located greater than 300 feet cable length from the facility, ferrous shielding is recommended but not required. For these landlines facility entrance surge protection shall be provided that fully complies with paragraph 4.2.2 and all sub paragraphs.

4.2.1.2.4 Conduit Joints and Fittings

Conduit joints and fittings shall be electrically continuous with bonding resistance of 5 milliohms or less between joined parts. Conduit enclosing signal, control, status, power, or other conductors to electronic equipment shall be terminated using conductive fittings to their respective junction boxes, equipment cabinets, enclosures, or other grounded metal structures.

4.2.1.3 Above Ground Ferrous Conduit Penetration of Facility

At each location, where above ground conduits first penetrate a shelter or building a bonding connection shall be made. The conduit shall be bonded directly to the EES, or to a bulkhead connector plate that is bonded to the EES in accordance with paragraph 4.2.1.6. If neither of these bonds is feasible, the bond shall be made to the main or supplemental ground plate. The bond to the EES, or the bulkhead connector plate, or to the multipoint ground plate shall be a 2 AWG stranded copper conductor using exothermic welds or UL listed pressure connectors.

4.2.1.4 Armored Direct Earth Burial (DEB) Cables

The DEB cable armor shall be bonded to the EES with a 2 AWG conductor prior to entry into the conduit. The DEB cable armor shall also be bonded to the main or supplemental ground plate. If bonding to the main or supplemental ground plates is not feasible the armor shall be bonded to the ground bus at the service disconnecting means (SDM). If armor is continued to the electronic equipment, bond it to any SRS – except to a single point ground system – of the electronic equipment unless the equipment is required to be isolated. All bonds shall be less than 5 milliohms between joined parts. Apply this requirement during initial cable installation. Complete cable replacement is not required if only a short length requires repair.

4.2.1.5 Guard Wires

A 1/0 AWG bare copper stranded guard wire shall be provided for all buried cables and conductors not routed in ferrous conduit. The guard wire shall be embedded in the soil, a minimum of 10 inches (25 cm) above the cable to be protected and located directly above and parallel to the lines or cables being protected. When the width of the cable run or duct does not exceed 3 ft (90 cm), one guard wire, centered over the cable run or duct, shall be installed. When the cable run or duct is more than 3 feet (90 cm) in width, two guard wires shall be installed. The guard wires shall be spaced at least 12 inches (30 cm) apart and be not less than 12 inches (30 cm) nor more than 18 inches (45 cm) inside the outermost wires or the edges of the duct. The guard wire shall be bonded to the EES at each end and to ground rods at approximately 90-foot intervals using exothermic welds. The spacing between ground rods must vary by 10% to 20% to prevent resonance. Install the ground rods at approximately 6 feet (2 m) on either side of the trench. Where cables run parallel to the edge of a runway, they shall be located 10 feet from the edge lights on the outside of the lights.

4.2.1.6 Metal Bulkhead Connector Plates

A metal bulkhead connector plate shall be provided where overhead axial-type cables, waveguides, etc., first enter a facility. The bulkhead connector plate shall be mounted on the outside surface of the facility, a minimum of $\frac{1}{4}$ inch thick, and shall be constructed of tin-plated copper. The plate or plates shall have the required number and types of feed-through connectors to terminate all axial cables and shall provide adequate surface area for bonding waveguides, cable shields, conduits etc. Cable shields shall be bonded and grounded, except when the shield must be isolated for proper equipment operation. If external and internal cables are of different sizes, the changeover in cable size shall be allowed by the feed-through connectors at the plate.

Axial type cables, Waveguides, etc.(and conduits where not bonded directly to the EES) shall be bonded to the bulkhead plates with a minimum 4 AWG bonding jumper. The 4 AWG bonding cable for a waveguide can be connected to the waveguide flange with an appropriately sized ring terminal. Conduits shall be bonded with a UL listed U-Bolt bonding connector. Axial cable shields shall be bonded with bonding kits sized for the specific cable type. Bonding jumpers shall be connected to the plate with either an exothermic weld or a double-bolted lug and shall be no longer than 12 inches.

The bulkhead plate shall be bonded to the EES with a minimum 4/0 AWG copper cable color-coded green with a red tracer. When the bulkhead connector plate is located within 6 feet of

building steel, the bulkhead plate shall be connected to building steel with a 4/0 AWG copper conductor color coded green with a red tracer. The building structural steel is required to be bonded to the EES. Exothermic welds shall be used for these connections.

4.2.1.7 Balanced Pair Lines

When possible, signal and control circuits routed external to equipment shall be balanced, two conductor, shielded circuits.

4.2.1.8 Fiber Optic Cable

Fiber optic cables are not inherently susceptible to electromagnetic interference or the induction fields produced by lightning. Fiber optic cables should replace metallic cables when economically and technically feasible. Ferrous conduit shielding is not required for fiber optic lines. Suppression components are not required for fiber optic cables. Where metallic or electrically conductive sheaths or strength members are present, they shall be grounded to any SRS – except to a single point ground system at each end. To prevent circulating ground currents, a SPD shall be allowed at one end for grounding. The fiber optic transmitter and receiver modules shall have 90 dB of attenuation against all sources of electromagnetic interference (EMI).

Where an external fiber optic cable uses conductive armor, the armor shall be bonded directly or via a SPD to the EES at the facility entrance using a 2 AWG bare copper conductor. If the cable is internal to the facility, conductive armor shall be bonded to any SRS – except to a single point ground system – at the equipment entrance. The bonding conductor shall be a 4 AWG stranded copper conductor insulated green with an orange tracer. The use of fiber optic cables without a conductive shield or armor is permitted. The fiber optic transmitter and receiver modules shall be contained in ferrous enclosures bonded to the nearest SRS – except to a single point ground system. Penetrations of the enclosures shall be gasketed or constructed to limit RF coupling. SPD's for the metallic signal circuits and power circuits shall be installed as equipment level protection at the fiber optic receiver or transmitter equipment entrance and bonded to the chassis.

4.2.1.9 Interior Lines, Conductors and Cables

All permanently installed single conductors, cables and wiring shall be in ferrous conduit (RGS), ferrous intermediate metal conduit (IMC), ferrous electrical metallic tubing (EMT), ferrous cable trays, or ferrous wireways (except as prohibited by the NEC). These shall be connected to any SRS – except to a single point ground system – as specified in paragraphs 4.2.6.4.1 and 4.2.6.4.2.

When routing between floors the vertical section of the runs shall be in ferrous conduit (RGS), ferrous IMC, ferrous EMT, enclosed ferrous cable trays, or ferrous wireways that are connected to any SRS – except to a single point ground system – as specified in paragraphs 4.2.6.4.1 and 4.2.6.4.2.

Cable tray systems employing single rail or wire construction are prohibited at any location.

4.2.2 Active Transient Protection Requirements

4.2.2.1 Conducted Power Line Surges

Surge protective devices (SPDs) shall be provided at the service disconnecting means (SDM), at all facility penetrations (entrances), and at feeder and branch panelboards as specified in paragraph 4.2.2.3. Additional SPDs shall be provided at the power line entrances to operational electronic equipment. SPDs at the service disconnecting means, facility penetrations (entrances), feeder and branch panelboards as well as transient suppression provided at electronic equipment power line entrances shall be coordinated in accordance with the guidance provided in paragraphs 4.2.2.2 and 4.2.2.3.

4.2.2.2 Facility Entrance Surge Protective Devices

A facility power SPD shall be installed on the load side of the facility service disconnecting means, at any facility penetration (entrance) and between the load side of a Engine Generator transfer switch and the first feeder panel.

The SPD shall be a combination of solid-state circuits, varistors, or other devices and shall meet the requirements provided in this paragraph and its subparagraphs. Protection will be provided between all lines, including neutral where provided, and ground. A surge arrester shall also be installed on the primary side of FAA owned distribution transformers. These arresters and SPDs shall be approved by the OPR of this document.

The SPD shall be installed as close as possible (within 12 inches) to the facility SDM and with the shortest and most direct conductor connection to the SDM. Connections shall be made with UL listed connectors identified for the wire size and type used.

- (a) Connections. SPD terminals shall be connected to corresponding terminals of the service disconnecting means with insulated 2 AWG (minimum) copper conductors. The conductors shall be as short and direct as possible without loops, sharp bends or kinks, be all the same size, and be color-coded in accordance with FAA-C-1217. The ground bus in the service entrance enclosure shall be bonded directly to the SPD terminal marked G or ground. The SPD enclosure shall be bonded to the SPD ground terminal.
- (b) Conduit sealing. The conduit connecting the SPD enclosure to the SDM enclosure shall be sealed with duct seal or other UL listed nonflammable medium to prevent soot from entering the SDM enclosure in the event of SPD failure.

4.2.2.3 Surge Protective Devices for Feeder and Branch Panels

SPDs shall be installed on all panels providing service to NAS operational equipment or supplying exterior circuits. Examples of exterior circuits include obstruction lights, convenience outlets, guard shacks, security systems, electric gates and feeds to other facilities. Exterior circuits shall be protected in accordance with the requirements of paragraph 4.2.2.2. Where feeder and branch panels are located close together and the panels do not serve exterior circuits, the OPR of this document shall be allowed to grant relief from providing separate protection on each panel. SPD's for panels that provide service to any exterior circuits shall meet the requirements given by paragraphs 4.2.2.4.2, 4.2.2.4.3, and 4.2.2.4.4 for facility entrance SPD's. The SPD's shall be installed as close as possible to the panel they serve and in accordance with the manufacturer's instructions. The conduit connecting the SPD enclosure to the panel enclosure shall be sealed with duct seal or other UL listed nonflammable medium to prevent soot

from entering the enclosure in the event of SPD failure. A feeder or branch panel SPD shall be provided with an overcurrent device. Examples of this overcurrent device include a fuse or circuit breaker fitted internally to the SPD or fitted to the panelboard for the sole use of the SPD. The overcurrent device shall not increase the clamp voltage of the SPD by greater than 5% and shall pass the surge current levels listed in Table IV up to the 40kA level without opening. Overcurrent devices for any exterior circuits shall pass all values shown in Table IV. All overcurrent devices, both internal and external to the SPD, and SPD short circuit current ratings shall be properly sized and coordinated in accordance with the NEC and be field resettable or replaceable.

4.2.2.4 SPD General Requirements

SPDs shall be listed in accordance with UL 1449 Second Edition. All components comprising a SPD shall be packaged in a single National Electrical Manufacturers Association (NEMA) type 12 steel enclosure for indoor use only, or a NEMA type 4 steel enclosure for indoor or outdoor use. SPDs enclosed within panelboards or switchgear enclosures shall be allowed, provided the integrated SPD and panelboard or switchgear is UL listed/recognized as components and as an assembly. The use of potting material in SPDs is strictly prohibited. All SPD components must be accessible for inspection by qualified FAA personnel. Heavy duty, screw-type studs shall be provided for all input and output connections. The SPD phase and neutral terminals, when not connected, shall be electrically isolated from the enclosure by a minimum of 10 megohms resistance measured at 100V DC. The enclosure door shall be hinged and electrically bonded with a bonding jumper to the enclosure. Fuses, lights, fuse wires, and arrester elements or components shall be readily accessible for inspection and replacement. Manufacturers shall supply clear installation instructions with each unit.

4.2.2.4.1 SPD Operational Characteristics

Minimum functional and operational characteristics of SPDs are given in Table IV, Table V, and Table VI. Other characteristics will also include the following:

- (a) Maximum continuous operating voltage (MCOV). The maximum continuous operating voltage is the maximum RMS voltage an SPD will withstand at its maximum operating temperature continuously without degradation or change to any of its parameters greater than +/- 10%. The MCOV shall not be less than 10 percent above the nominal system voltage. Leakage current as defined below shall not be exceeded.
- (b) Leakage current. The DC leakage current shall be less than 1mA for voltages at or below $1.414 \times \text{MCOV VDC}$.
- (c) Clamp (discharge) voltage. Clamp (discharge) voltage is the maximum voltage that appears across an SPD output terminal while conducting surge currents. This voltage, measured at 3kA (to ensure performance in the linear region without impacting the device lifetime performance) with an 8/20 microsecond waveform, shall not change more than 10 percent over the operating life (as defined in Table IV. Surge Current Lifetime Requirements) of the SPD.
- (d) Overshoot voltage. Overshoot voltage shall not exceed twice the SPD clamp voltage for more than 10 nanoseconds. Overshoot voltage is the surge voltage level that appears across the SPD terminals before the device turns on and clamps the surge to the specified voltage level.

- (e) Self-restoring capability. The SPD shall automatically return to an off state after surge dissipation when line voltage returns to normal.
- (f) Operating lifetime. The SPD shall safely dissipate the number and amplitude of surges listed in Table IV. Surge Current Lifetime Requirements.
- (g) In-line inductors. In-line inductance, other than that normally caused by routing conductors, is not permitted.
- (h) Fusing. Any fuses part of a SPD installation shall be able to pass all surge currents specified in Table IV without opening.

4.2.2.4.2 Surge Levels

Table IV defines line-to-ground, line-to-neutral, neutral to ground, and line-to-line surge currents, and number of occurrences for AC services in FAA facilities below 600V. In this table, the 8/20 μ s wave form defines a transient reaching peak value in 8 μ s and decays to 50 percent of peak value 20 μ s after inception. These devices shall be able to tolerate surges of shorter duration without malfunction.

Table IV. Surge Current Lifetime Requirements

Surge Current Amplitude 8/20μs Waveform	Surge Number Lifetime Any Facility Entrance	Surge Number Lifetime Feeder and Branch Panels
10kA	1500	1000
20kA	700	500
30kA	375	250
40kA	50	25
50kA	8	1
60kA	6	
70kA	4	
100kA	2	
200kA	1	

Each level of surge current and the number required represents a single lifetime of an SPD.

- (a) Any change greater than 10% in the 8/20 μ s clamping voltage at 3kA during service or when the pre life/service test and the post life or in-service test results are compared is a device failure. The pre life test value shall be taken as the 100% value.
- (b) Any change greater than 10% in the RMS voltage required to drive 1mA RMS through the device when the pre life/service test and the post life or in-service test results are compared is a device failure. The pre life test value will be taken as the 100% value.
- (c) Any change greater than 10% in the DC voltage required to drive 1mA DC through the device when the pre life/service test and the post life or in-service test results are compared is a device failure. The pre life test value will be taken as the 100% value.
- (d) Clamping voltages for each of the devices/assemblies/system voltages will be measured at 1kA and 10kA 8/20 μ s.

4.2.2.4.3 Slope Resistance

It is the purpose of this parameter to specify a region on the SPD characteristic where it is possible to ensure device coordination. A slope resistance (the slope of the voltage/current characteristic of an SPD in its linear region) shall be calculated from the formula below:

$$R_{\text{slope}} = (V_{10} - V_1) / 9000$$

Where V_{10} = the clamping voltage measured at 10kA 8/20 μ s
and

Where V_1 = the clamping voltage measured at 1kA 8/20 μ s

The values of V_{10} and V_1 used will be the absolute values as measured and not as a calculated value. The slope values shall conform to Table V.

Table V. Entrance, Feeder, and Branch Panels Slope Resistance Requirements

Location	Slope Resistance
Any Facility Entrance	8 m Ω Maximum
Feeder and Branch Panels	30 m Ω +/- 15 m Ω

4.2.2.4.4 3kA Voltages V_3

The voltages that must be achieved during testing at 3kA with an 8/20 μ s current impulse is shown in Table VI. All voltages shall be measured at the device terminals. The 8/20 μ s current impulse wave shape shall not lead or lag the voltage wave shape by more than 30 degrees.

Table VI. Protection Voltages at 3kA

Location	System	V_3	Limit
Any Facility Entrance	120/208V 120/240V	400 L-N, L-G 700 L-L	Maximum
Any Facility Entrance	277/480V	700 L-L, L-G	Maximum
Any Facility Entrance	380V Delta	1200 L-L, L-G	Maximum
Any Facility Entrance	480V Delta	1200 L-L, L-G	Maximum
Feeder and Branch panels	120/208V 120/240V	475 L-N, L-G 775 L-L	+/- 45V
Feeder and Branch panels	277/480V	775 L-N, L-G 1275 L-L	+/- 45V
Feeder and Branch panels	380V Delta	1275 L-L, L-G	+/- 45V
Feeder and Branch panels	480V Delta	1275 L-L, L-G	+/- 45V

4.2.2.4.5 Indicator Lamps

Indicator lamps shall be provided for each phase on the SPD enclosure cover. They shall visually indicate normal condition (power applied to the SPD with any component fuses intact).

If indicator lamps are used that have a service life of less than 50,000 hours then two lamps per phase shall be provided.

4.2.2.4.6 Accessibility

All SPD installations shall be safely accessible for visual inspection and evaluation. The use of potting material or other encapsulating materials that prevent component inspection in SPDs shall be limited to inorganic particulates. All SPD components shall be accessible for maintenance and replacement by qualified FAA personnel. Determination of the acceptability of potting material or other encapsulating materials in a given design resides with the OPR of this document.

4.2.2.5 Signal, Control, and Data Line Protection Design

Transient protection shall be provided for all signal, data and control lines; both at facility entrances and at entrances to all electronic equipment used in direct support of the NAS including those provided or installed by a telecommunications service provider.

The suppression components at the facility and electronic equipment entrances shall be coordinated to function together and limit the transient voltage and energy safely below circuit susceptibility levels. Coordination of suppression components is dependant on several factors including separation distance, equipment system bandwidth, etc. In principle facility entrance devices and electronic equipment entrance devices shall not affect each others operation. The coordination of these protectors is achieved at the system design stage – not intended to be accomplished by field personnel (see paragraph 4.3.2).

Detailed analyses of suppression component and electronic equipment circuit characteristics are required to select components compatible with the requirements herein and to provide suppression circuits that will function without adversely affecting signals and information transmitted by individual landlines. Design requirements for selection of components are as follows:

- (a) Unipolar suppression components shall be selected and installed for signals and voltages that are always positive or always negative relative to reference ground. Bipolar suppression components shall be selected for signals and voltages that are both positive and negative relative to reference ground.
- (b) The total series impedance of the suppression circuits at both ends of a landline shall be designed so as not to significantly degrade electronic equipment performance.
- (c) The protection components at facility entrances and equipment shall be selected so that their operating levels are coordinated and transient levels to equipment are limited safely below electronic equipment susceptibility levels for individual lines.

Surge protective devices shall be placed on both ends of signal, data and control lines longer than 10 feet connecting pieces of equipment or facilities not located on and bonded to the same SRS, or when the SRGG, SRGP, and the multipoint ground system is located in different rooms or on different floors. This includes all signal, data, control, and status lines both internal and external. This also includes interfacility lines installed above and below grade between facility structures and to externally mounted electronic equipment and particularly vertically routed conductors and

cables such as those between an ATCT cab and base building or radar tower and base building. This requirement includes fire alarm and security wiring where it has direct impact on NAS equipment.

All unused conductors of a cable shall be grounded at each end. Grounding through an SPD is permissible if grounding both ends of the conductors degrades system performance.

4.2.2.6 SPD Requirements for Signal Data and Control Lines

Facility level SPDs for signal, data, and control lines shall be installed at the point where the lines transfer to FAA control and at any building/structure entrance under FAA control. Where a battery feeds signal, data or control lines, the suppression components shall be housed in a metal enclosure. For facility level SPD enclosures, a ground bus bar, electrically isolated from the enclosure, shall be provided to serve as the ground point. This ground bus bar shall be directly connected to the EES with an insulated 4 AWG or larger copper conductor of minimum length with no loops, sharp bends or kinks, and ensure a short direct path for connection to the SPD's. NOTE: When at the top of a tall ATCT (greater than 100 feet) the main ground plate on the lowest level containing NAS electronic equipment serves in lieu of the EES. The conductor insulation shall be color-coded green with a red tracer. A UL listed double bolted lug shall be used to bond the conductor to the ground bus bar. The bonding to the EES shall be an exothermic weld. The ground bus bar location shall ensure a short, direct path to ground for SPD's. The installation shall provide easy access to component terminals for visual inspection, test and replacement.

SPD's for landlines that combine the protection specified herein shall be located at the facility entrance, and have approval by the OPR of this document prior to implementation of vendor proposed protection. (Reference paragraph 4.2.2.5)

Field designed protection schemes shall be submitted to the OPR of this document for guidance and approval.

Transient suppression components for axial-type cables shall be packaged in a sealed metal enclosure with appropriate connectors at each end to permit in-line installation at the bulkhead connector plate required in paragraph 4.2.1.6.

4.2.2.6.1 Signal, Control, and Data Line Protection Requirements

The 10/1000 μ s waveform defines a transient with a 10 μ s rise time and decay to 50 percent of the peak voltage in 1000 μ s. SPDs must survive the transients listed in Table VII. Failure or end of life performance of a protector shall not normally disrupt the operation of the circuit being protected.

Table VII. SPD Lifetime Conducted Landline Transient Level Requirements

Lifetime Number of Transients	Transient Levels	
1,000	100V	50A
500	500V	100A
50	750V	375A
5	1000V	1000A

Each level of surge current and the number required represents a single lifetime of an SPD.

4.2.2.7 Axial Cable Protection Design

Special attention shall be given to the design of transient protection for axial-type cables. Design of transient protection is particularly critical at RF frequencies due to insertion losses. The following design requirements apply:

- (a) Analyses and tests shall be performed to assure that suppression components do not degrade signals to an unacceptable degree or cause marginal performance of electronic equipment.
- (b) Particular attention shall be given to the impedance, insertion loss, phase distortion, and voltage standing wave ratio for RF signals.
- (c) Transient protection for electronic equipment using coaxial, tri-axial, and twin-axial cables shall be provided both at facility entrances and at the electronic equipment.

Transient suppression shall be provided for each axial conductor and for shields that are not bonded directly to the electronic equipment case.

4.2.3 Lightning Protection System Requirements

4.2.3.1 General

The intended purpose of the lightning protection system is to provide preferred paths for lightning discharges to enter or leave the earth without causing facility damage or injury to personnel or equipment. The essential components of a lightning protection system are air terminals, roof and down conductors connecting to the EES, the EES and SPDs. These components act together as a system to dissipate lightning energy. The lightning protection system shall meet or exceed the requirements of all relevant FAA standards and orders; Standard for the Installation of Lightning Protection Systems, National Fire Protection Association (NFPA 780); Installation Requirements for Lightning Protection Systems, Underwriters Laboratories (UL 96A); and, as specified herein. The risk assessment guide in NFPA 780 indicates that many NAS facilities have a high risk index. Accordingly lightning protection that exceeds the minimum requirement of NFPA 780 is specified. The provision of a UL Master label is not sufficient to indicate compliance with this document.

4.2.3.2 Lightning Protection System Materials

All equipment shall be UL listed for lightning protection purposes and marked in accordance with UL requirements. All equipment shall be new and of a design and construction to suit the application in accordance with UL 96A requirements, except that aluminum shall only be used on aluminum roofs, aluminum siding or other aluminum surfaces. Bimetallic connectors shall be used for interconnecting copper and aluminum conductors. Dissimilar materials shall conform to the bonding requirements of paragraph 4.1.1.2.3.

4.2.3.2.1 Lightning Protection System Conductors

All conductors used in a lightning protection system (main and bonding) shall be class 2 main sized conductors as defined by NFPA 780 or larger.

4.2.3.2.2 Lightning Protection System Hardware

4.2.3.2.2.1 Fasteners

Roof and down conductors shall be fastened at intervals not exceeding 3 feet (0.9 m). Fasteners shall be of the same material as the conductor base material or bracket being fastened, or other equally corrosion resistant material. Plastic, galvanized or plated materials shall not be used. Where fasteners are used for bonding the surface shall be prepared and protected in accordance with paragraphs 4.1.1.7 and 4.1.1.8.

4.2.3.2.2.2 Fittings

Bonding devices, conductor splices, conductor attachments and connectors shall be suitable for use with the installed conductor and shall be stainless steel, copper, bronze, or aluminum with bolt pressure connections to the conductor. Crimp type fittings shall not be used anywhere for any purpose in the lightning protection system. Aluminum fittings shall only be used with aluminum conductors. Copper and bronze fittings shall only be used with copper conductors. Interconnection between copper and aluminum portions of the lightning protection system shall be accomplished with bimetallic connectors.

4.2.3.2.3 Guards

Guards shall be provided for down conductors located in or next to driveways, walkways or other areas where they are at risk of being displaced or damaged. Guards shall extend at least 6 feet (1.8 m) above and 1 foot (0.3 m) below grade level. Guards shall be schedule 40 polyvinyl chloride (PVC) conduit or better. When metal guards are used, the guard shall be bonded to the down conductor at both ends of the guard. Bonding jumpers shall be of the same size as the down conductor. PVC guards do not require bonding.

4.2.3.3 Lightning Protection System Bonds

4.2.3.3.1 Metallic Bodies Subject to Direct Lightning Strikes

Metallic bodies that protrude beyond the zone of protection provided by the installed air terminals, are subject to direct lightning strikes. This includes, but is not limited to, exhaust pipes, exhaust fans, metal cooling towers, HVAC units, ladders, railings, antennas, and large louvered structures, etc. When these metallic bodies have a metal thickness of $\frac{3}{16}$ inch or greater, they shall be bonded to the nearest main lightning protection system conductor. These

fittings shall provide bonding surfaces of not less than 3 square inches. If the metal parts of these units are less than $\frac{3}{16}$ inch thick, additional air terminals, main conductors and fittings shall be installed, providing two paths to ground from the air terminals.

4.2.3.3.2 Metallic Bodies Subject to Induced Charges

Metallic bodies that are subject to induced charges from lightning (including those in a zone of protection) shall be bonded to the lightning protection system in accordance with the guidance provided in NFPA 780. This includes, but is not limited to, roof drains, vents, coping, flashing, gutters, downspouts, doors, door and window frames, balcony railing, conduits, pipes, etc.

4.2.3.3.3 Exhaust Stack Grounding.

Bond all fossil fuel exhaust stacks to the nearest point in the lightning protection system or directly to the EES with a conductor of equal size as the main conductor. The bond to the exhaust stacks shall be made with an exothermic weld or a mechanical connector. Where exhaust stacks are not in close proximity (6 feet) to a main conductor, they shall be bonded directly to a ground rod in the EES.

4.2.3.3.4 Above Ground Fuel and Oil Storage Tanks.

Lightning protection shall be provided for all above-ground fuel and oil storage tanks. An air terminal shall be mounted to the top of non-pressurized fuel and oil tank vent pipes, high enough to provide the required zone of protection for the entire tank, and be connected directly to the EES using a main-sized down conductor.

Tanks shall be provided with at least two easily accessible, widely separated grounding points. Each of these grounding points shall be bonded directly to the EES. All other metallic components, e.g., stairs and skids, shall be bonded with 4/0 AWG copper conductors or if 4/0 AWG is not feasible then the largest feasible conductors. These conductors shall be exothermically welded to the EES.

Pressurized fuel tanks (propane, compressed natural gas, etc.) shall be bonded directly to the EES at one of the support legs.

4.2.3.4 Conductor Routing

Down conductors shall follow the most direct downward course. Main and bonding conductors must maintain a downward or horizontal course, and are permitted to rise at no greater than $\frac{1}{4}$ pitch.

No bend in a main and bonding conductor shall form an included angle of less than 90 degrees, nor shall it have a bend radius (sweep) of less than 8 inches. Connections between crossing conductors will use sweeps in all directions. T-connectors shall be allowed only for mechanical support.

Conductors shall be routed outside of any structure and not penetrate or invade that structure (except as indicated below in paragraph 4.2.3.6). Conductors shall be routed 6 feet or more from

power or signal conductors in air or through walls. If this clearance cannot be met, the power and signal conductors shall be routed in ferrous conduit (RGS) or enclosed ferrous cable tray.

Conductors shall be allowed to pass through a parapet, eave, walkway, wall, etc., where necessary to maintain horizontal or downward course of main conductors. Pass-throughs shall always be accomplished using main conductors, routed through Trade Size 2, Schedule 80, rigid PVC conduit. When a conductor penetrates a metallic structure of any thickness, the conductor shall be bonded to the metallic structure. Conductors passing through gratings or plates do not require conduit but do require bonding.

4.2.3.4.1 Down Conductors on Fiberglass Mounting Poles

Where a fiberglass pole is used to mount an air terminal, the air terminal shall extend two feet above the top of the pole and shall be securely fastened to the pole in accordance with the requirements of NFPA 780. The down conductor from the air terminal shall be run on the exterior of the fiberglass pole and shall be fastened to the pole at intervals not exceeding 3 feet. This down conductor shall be connected to the EES in accordance with paragraph 4.2.3.4.2.

4.2.3.4.2 Down Conductor Terminations

Down conductors shall be exothermically welded to a 4/0 AWG copper conductor prior to entering the ground at not less than 18 inches above the ground level. The 4/0 AWG copper conductor shall enter the ground and be welded to a ground rod that is exothermically welded to the EES.

4.2.3.5 Lightning Protection for Buildings and Structures

Lightning protection shall be provided for all buildings and structures, or parts thereof, not within a zone of protection provided by another building or higher part of a building, or by an antenna or tower. Zones of protection for all structures shall be as defined in NFPA 780.

4.2.3.5.1 Air Terminals

Air terminals shall be solid copper, bronze, or aluminum. In areas of high corrosion, air terminals shall be stainless steel. Copper air terminals shall be allowed to have nickel-plating. Air terminals shall be a minimum of 12 inches in height, at least $\frac{1}{2}$ inch in diameter for copper and at least $\frac{5}{8}$ inch in diameter for aluminum. Air terminals shall be located and installed in accordance with the requirements of NFPA 780 and UL 96A, and as required by this document. Closer spacing shall be allowed for unique geometries. Air terminals shall extend at least 10 inches above the object or area it is to protect. Air terminals shall be placed on the ridges of pitched roofs and around the perimeter of flat or gently sloping roofs at intervals not exceeding 20 feet except that air terminals 24 inches or higher shall be allowed at intervals not exceeding 25 feet.

SAFETY NOTE:

The tip of vertical air terminals shall not be less than 5 feet above adjacent walking or working surfaces to avoid the risk of personnel injury.

4.2.3.5.2 ATCT Potential Equalization

A continuous potential equalization loop (halo ring) shall be installed on the roof or roof parapet, within 24 inches of the periphery of the structure. All air terminals and down conductors shall be connected to this loop. Any parts of the structure below the roof level that extend outboard of the potential equalization loop shall be provided with additional air terminals at the extremities of the structure.

Potential equalization loops shall be installed at intermediate levels, evenly spaced no more than 60 feet apart, measured from the roof loop. Additional horizontal air terminals will be installed at each potential equalization loop.

All exterior catwalks and personnel access areas shall be provided with a potential equalization loop interconnected to the down conductors. Horizontal air terminals shall be installed at each corner.

4.2.3.5.3 Number of Down Conductors for Buildings

The number of down conductors shall be based of both the building height and perimeter. For the purpose of this paragraph, an ATCT with a base building shall be treated as two separate buildings.

Buildings and structures less than 50 feet high (measured to the highest point of the building or structure) shall have at least two down conductors. Buildings and structures more than 50 feet and less than 100 feet high shall have at least four down conductors. Buildings and structures more than 100 feet high, other than antenna towers, shall have one additional down conductor for each 50 feet of height or part thereof, e.g., a 150 foot building would have a minimum of five down conductors, a 300 foot building would have a minimum of eight down conductors, etc.

Buildings and structures with perimeters in excess of 250 feet shall have an additional down conductor for each 100 feet of perimeter distance or part thereof. Down conductors shall be as widely separated as possible, e.g., at diagonally opposite corners on square or rectangular buildings. The down conductors shall be equally spaced and without any sharp bends, or kinks. Building steel, metal supporting structures, and conduits shall not be used in place of down conductors.

4.2.3.5.4 Metal Parts of Buildings

Metal roofing, structural and reinforcing steel, siding, eave troughs, down spouts, ladders, duct, and similar metal parts shall not be used as substitutes for roof or down conductors. A lightning protection system shall be applied to the metal roof and to the metal siding of a metal clad building in the same manner as on a building without metal covering. Building metal parts shall be bonded in accordance with paragraph 4.2.3.3.

4.2.3.5.5 Roof Mounted Antenna Masts

Unless it is a radiating or receiving part of the antenna, a metallic mast of a roof-mounted antenna shall be bonded to the nearest roof or down conductor. If a roof or down conductor is not available then the antenna mast shall be bonded directly to the EES.

4.2.3.6 Lightning Protection for Antenna Towers

4.2.3.6.1 Number of Down Conductors for Towers

Towers that consist of multiple, parallel segments or legs that sit on a single pad or footing not over nine square feet in area are also considered pole type towers. All other towers shall have at least two down conductors. Large towers, such as radar towers, shall have one down conductor per leg. Down conductors on all towers shall be bonded to each tower section. Down conductors shall be routed down the inside of the legs wherever practical and secured at intervals not exceeding 3 feet.

4.2.3.6.2 Pole Type Towers

Pole type towers shall be protected by at least one air terminal and have at least one down conductor. This is to provide a zone of protection for all antennas located on the tower.

4.2.3.6.3 Towers without Radomes

Protection shall be provided for large radar antennas by extending structural members above the antenna and mounting the air terminal on top as shown in Figure V unless specifically disapproved by the Radar system OPR. Structural members shall be braced as necessary and shall not be used as part of the air terminal or down conductor. The air terminal shall be supported on the structural member and shall have a UL listed fitting on its base. The down conductor from the air terminal shall be connected to a perimeter conductor that forms a loop around the perimeter of the tower platform. Down conductors shall be run from the perimeter conductor to the EES. Each air terminal shall be provided with at least two paths to ground. All conductors shall be in accordance with NFPA 780 requirements for main conductors. All tower legs shall be bonded to the EES with a 4/0 AWG copper conductor exothermically welded at each end. This bonding conductor shall be either a separate conductor, or is permitted to be a part of the down conductor, as described in paragraph 4.2.3.4.2.

4.2.3.6.4 Radomes

Radomes shall be located within a zone of protection established according to the 100 foot radius "rolling sphere model" as described in NFPA 780. This protection can be either from air terminals mounted on the radome or air terminals or catenary wires mounted independently of the radome. When air terminals are mounted on the radome they must have two paths to the EES. A perimeter conductor shall be established at the radar antenna deck level.

Lightning protection systems for standalone radomes shall be designed and installed in consultation between the system OPR and the OPR of this document. The narrative in paragraph 4.2.3.6.5 shall be used as guidance in developing lightning protection systems for these radomes.

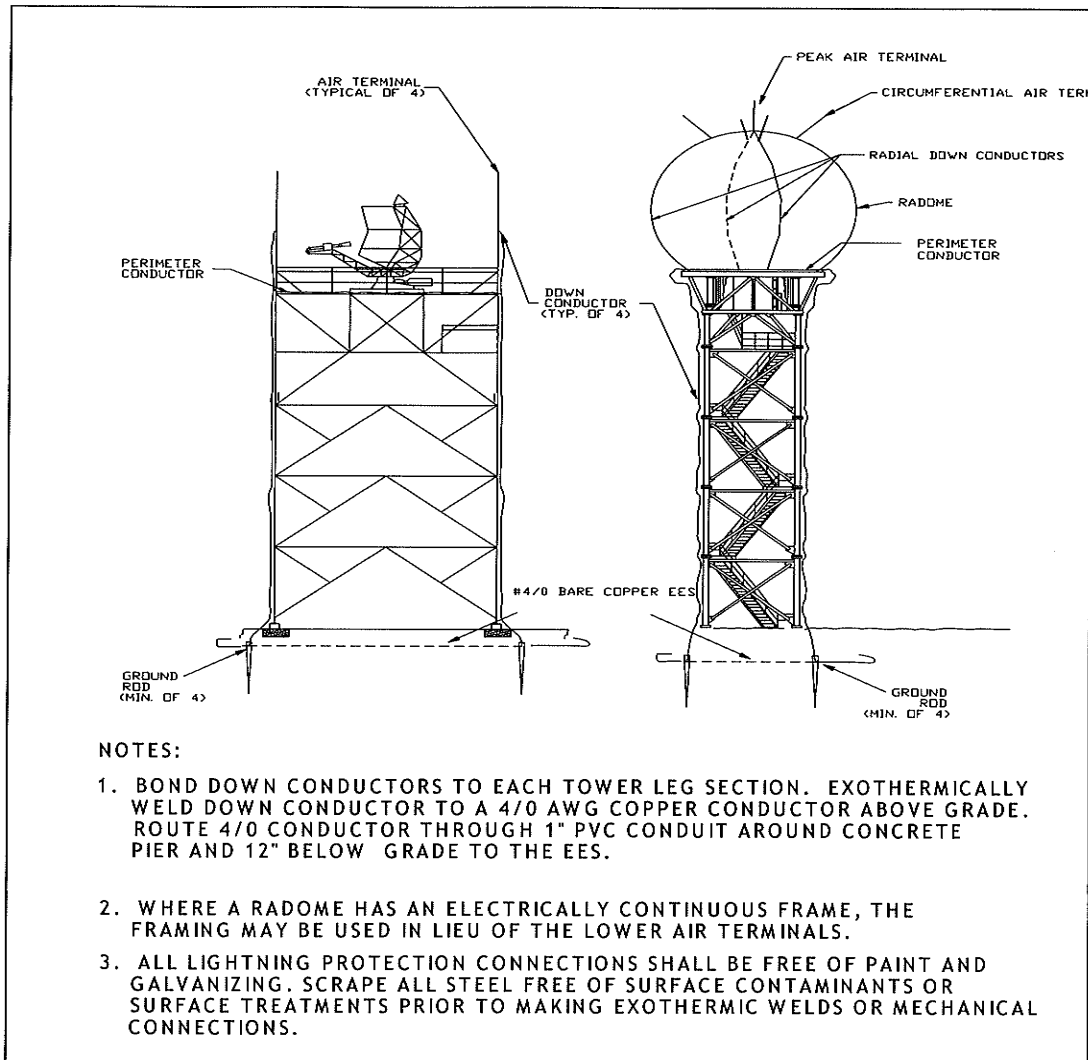

Figure V. Lightning Protection for Radomes and Radar Antenna Platforms

4.2.3.6.5 Towers with Radomes

Lightning protection systems for towers with radomes shall be designed and installed in consultation between the system OPR and the OPR of this document. The narrative below shall be used as guidance in developing lightning protection systems for these structures.

Towers with radomes shall be protected with a minimum 2 foot (0.62 m) air terminal at the peak and four or more air terminals equally spaced around the circumference of the radome and oriented perpendicular to the radome. The spacing and quantity of the circumferential air terminals shall be adjusted if the antenna pattern is affected, but their sizing, position and height shall establish a protection zone as specified in 4.2.3.6.4. The circumferential air terminals shall be interconnected with main sized conductors. The radial down conductors, as indicated in Figure V, shall be connected to the air terminal on the peak. The radial down conductors shall also be connected to the perimeter conductor that forms a loop around the base of the radome.

The radial down conductors on the radome shall be routed from the air terminal at the peak of the radome, in a path following the contour of the radome, to connection with the circumferential air terminals and then to connection with the perimeter conductor as shown in Figure V. Deviations from the shortest possible path shall be allowed where near field radar analyses determine that interference from the conductors will degrade the performance of the radar. Any bends in the radial down conductors on the radome shall maintain the largest possible radii and in no case be less than 12 inches. One down conductor per leg shall connect the perimeter conductor at the base of the radome to the EES. The down conductors shall be bonded to each leg section. All tower legs shall be bonded to the EES with a 4/0 AWG copper conductor exothermically welded at each end. This bonding conductor can be the same conductor required in paragraph 4.2.3.4.2.

4.2.3.6.6 Antenna Protection

Air terminals shall be placed to protect structural towers and buildings, and antennas mounted to towers and on buildings.

4.2.3.6.7 Tower Guying

All metallic guy wire systems without insulators shall be connected to the EES with a 4/0 AWG copper conductor.

4.2.3.6.7.1 Anchors

Where multiple guy wires terminate on a single anchor, one jumper shall be allowed to connect all guy wires to the EES. The jumper shall be exothermically welded to a ground rod that is exothermically welded to the EES. Mechanically bonded jumpers of the same material and size as the guy wire shall be placed across any intermediate turnbuckles in a guy wire. On guy wires terminating in low conductivity anchors (such as concrete), a jumper of the same material and size as the guy wire shall be mechanically bonded to each guy wire above its lowest turnbuckle and bonded to the EES. All jumper connections to the guy wires shall be made with appropriate compatible connectors.

4.2.3.6.8 Waveguide, Axial Cable, and Conduit Grounding

Waveguide, axial cable, and conduit located on the tower and feeding into the facility shall be separately bonded to a ground plate mounted on the tower or directly to the EES. This bond shall be above and no greater than 2 feet (0.6 m) from the transition bend (90 degree bend) near the tower's base. Bond the ground plate to the EES with a 4/0 AWG copper conductor in accordance with the requirement in paragraph 4.2.1.6. A separate bond shall be made from the point of origin within the tower structure of each waveguide, axial cable, or conduit to the metallic tower structure. These are in addition to the bulkhead connector plate required in paragraph 4.2.1.6.

4.2.3.6.9 Staircase/Ladder Protection

The metallic access to the tower, i.e., staircase, ladder, etc., shall be exothermically bonded near its base to the EES with a 4/0 AWG copper conductor installed in a location that avoids accidental tripping or striking that could result in personnel injury. Where staircase sections, platforms etc. are not welded together, bonding jumpers shall be installed between them.

4.2.3.7 Lightning Protection for Facilities without Buildings or Antennas

Facilities such as Runway Visual Ranges are commonly built without buildings or antennas. While these are small facilities their loss can have an impact on the NAS far out of proportion to their size. These small facilities must be included within a zone of protection established with either air terminals or overhead catenary wires to prevent damage from lightning strikes.

4.2.3.8 Lightning Protection for Fences and Gates

General airport fencing is not subject to the mandates of this document. Non-FAA owned fencing, that is adjacent to FAA facilities and meets the distance criteria set out in this and sub paragraphs, shall be protected as mandated after agreement with the owner of the fencing. Fences shall be constructed using electrically conducting materials e.g., chain link fabric, metal crossbar, stranded wire, etc., using metal posts that extend a minimum of 2 feet (0.6 m) below grade into a concrete base. Metallic fence fabric with non-conductive coatings shall not be used.

A ground rod shall be installed at spacings no greater than 100 feet, and bonded to a fence post with a 4/0 AWG stranded copper conductor, exothermically welded. Install a 1 inch by $\frac{1}{8}$ inch flexible tinned copper bond strap or an insulated 4/0 AWG flexible (welding) copper conductor from any gate to the adjacent post (exothermic welding is recommended). Install the bonding strap from the gate to the post so it will not limit full motion of the gate (whether swing or slide type). Exothermically weld a 4/0 AWG bare copper conductor from the posts at each side of the gate to ground rods installed at each side of the gate. Connect the conductor to the gateposts at a height no greater than one foot above grade. Interconnect the ground rods at either side of the gate with an exothermically welded 4/0 AWG bare copper conductor buried a minimum of 18 inches below grade.

Bond across any terminations in the security wire using a short piece of the security wire material and UL listed bonding connectors. Bond the security wires to the fence posts at intervals of approximately 40 feet using a 6 AWG stranded tinned copper conductor and UL listed bonding connectors. Attach the metallic fence fabric to the fence posts with wire ties of the same material. The method of bonding fences is illustrated in Figure VII.

For gates, a horizontal bare 6 AWG stranded tinned copper conductor shall be threaded continuously through the gate fabric and mechanically bonded to the vertical gate rails.

Portions of a fence that are within 22 feet of a facility EES shall be bonded to that EES with a 4/0 AWG bare copper conductor exothermically welded to a fence post ground rod. Connections shall be made at a maximum interval of 40 feet with a minimum of two connections.

The above requirements are designed to meet the minimum National Electrical Safety Code (NESC) ANSI C2, Rule 92E. and IEEE Std 80.

Long fences, of 100 feet or greater, shall be positioned so they do not approach any part of an FAA lightning protection system closer than 50 feet if at all feasible. Grounding for portions of long fences that approach closer than 50 feet to any part of a FAA lightning protection system shall be referred to the OPR of this document.

4.2.3.8.1 Fences in High Risk Locations

NFPA 780 identifies the ability of structures to attract lightning from a significant surrounding area increasing the lightning strike frequency. For NAS facilities, the calculated high risk indices and lightning strike frequency values identify an “increased risk of strike”, resultant damage, step potentials and touch potentials for adjacent areas. Consequently certain facilities require additional fence grounding for portions of the fence that fall within the combined area produced by drawing a boundary around each structure equal to 1.5 times the height of that structure in accordance with Figure VI Common Collective Area of Increased Risk. This additional fence grounding shall be in accordance with paragraph 4.2.3.8.2. This requirement applies to the following facilities.

- a) Radar sites such as ASR, ARSR, TDWR, PRM.
- b) ARTCC's
- c) ATCT's over 100 feet in height (tall towers)
- d) Large TRACON's

Grounding for fences for structures such as VOR, RTR, RCAG and lighted Navaids shall be in accordance with the site configuration design controlled by the program offices for those systems and have the approval of the OPR of this document.

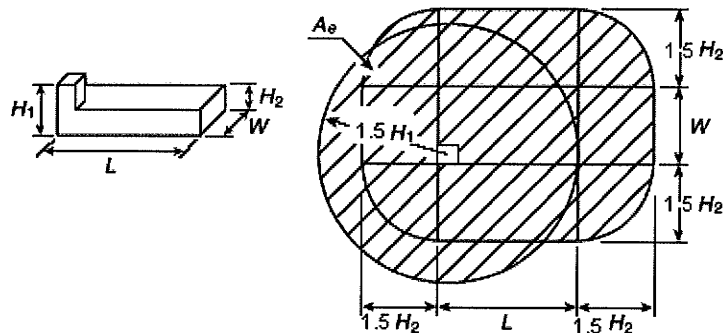

Figure VI Common Collective Area of Increased Risk

4.2.3.8.2 Fence Grounding for High Risk Locations

A buried bare 4/0 AWG stranded copper conductor (fence EES) shall be installed outside the fence where feasible (inside where not), within three feet of the fence, and two feet below grade. A horizontal bare 6 AWG stranded tinned copper conductor shall be threaded through the fencing fabric, approximately midpoint of the fence fabric, and shall be mechanically bonded to the fence posts at intervals not greater than 40 feet. A ground rod is required at these bonding locations and exothermically welded to the fence EES. The fence posts at these bonding locations shall be bonded to the fence EES with a bare 4/0 AWG stranded copper conductor,

exothermically welded to the fence posts and to the ground rod. The method of bonding a fence requiring an EES is illustrated in Figure VIII.

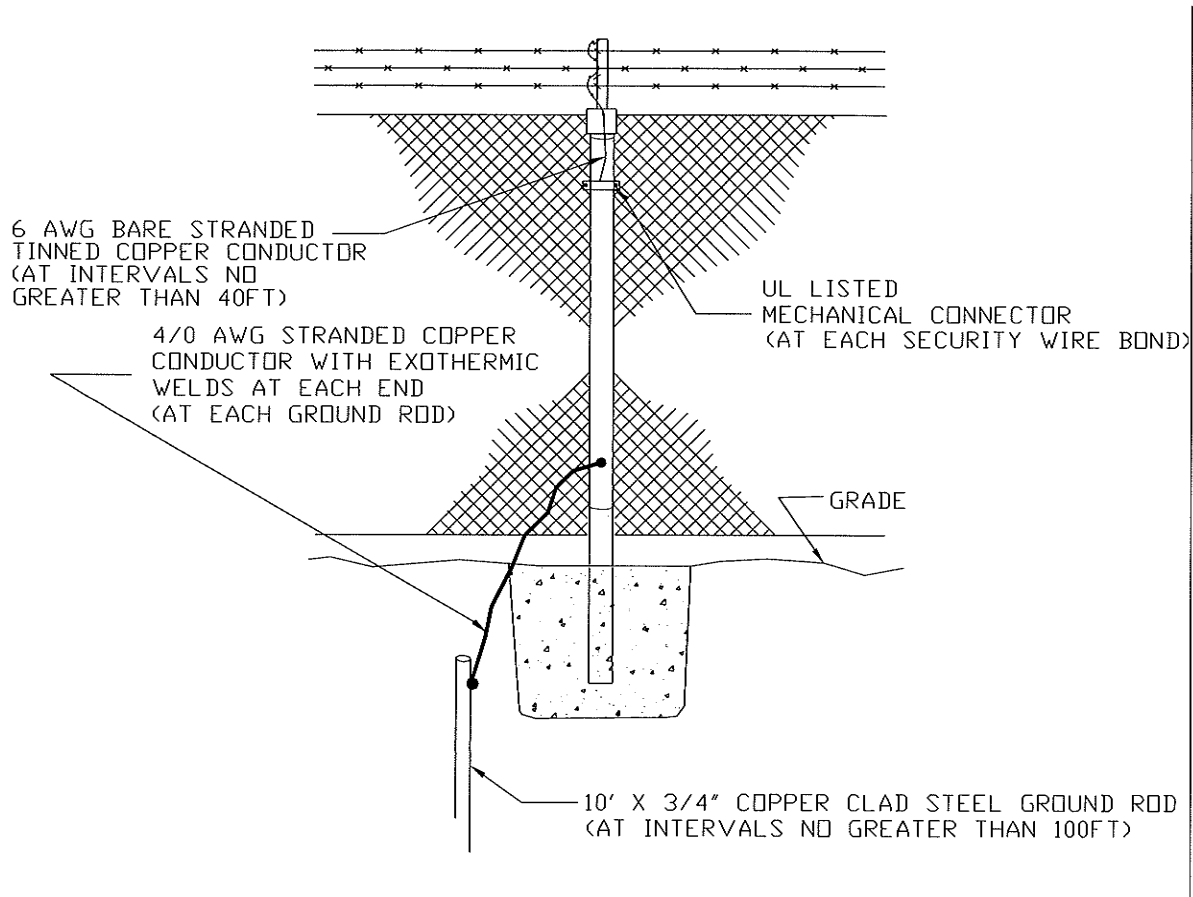

Figure VII. Fence Grounding

The fence EES shall be connected to other EES within the fence EES using buried bare 4/0 AWG stranded copper conductors. A minimum of four connections shall be installed between the fence EES and other EES for structures or buildings with an aggregate footprint of 5,000 square feet or less (preferably at the corners). A minimum of eight connections shall be installed between the fence EES and other EES for structures or buildings with an aggregate footprint greater than 5,000 square feet (preferably at the corners and at the midpoints). Aggregate footprint is defined as the sum of all building and structure footprints.

For swing gates, the horizontal bare 6 AWG stranded tinned copper conductor in the fence fabric shall continue to and be threaded through the gate fabric.

4.2.3.8.3 Fences Crossed by Overhead Power Lines

When overhead power lines cross a fence, bond a fence post on each side of the crossing to a ground rod with a bare 4/0 AWG copper conductor. These connections shall be on each side of and at least 20 feet from the overhead wire crossing. Bond the fence fabric at the top, middle and bottom of the fence and each strand of security wire placed above the fencing fabric to the grounded post with a bare 6 AWG tinned copper conductor. Where crossbars or stranded wire is used, each horizontal strand or cross bar shall be bonded to these posts. Figure VIII shows a typical fence post grounding and bonding.

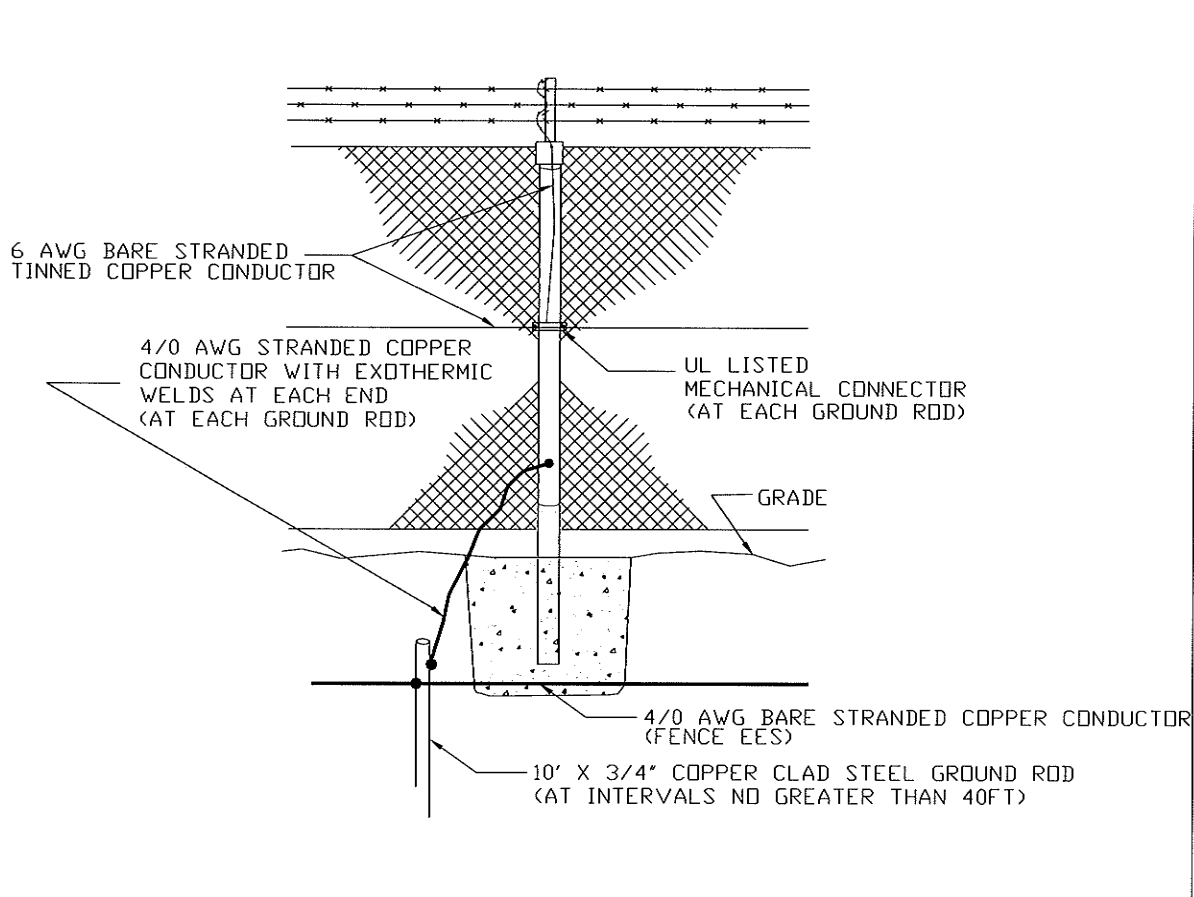

Figure VIII. Grounding Fences Requiring an EES

4.2.4 Earth Electrode System (EES) Requirements

4.2.4.1 General

An EES shall be installed at each facility. The purpose of the EES is to provide a low resistance to earth for lightning discharges, electrical and electronic equipment grounding and surge and transient protection. The EES shall be capable of dissipating within the earth the energy of direct

lightning strikes with no ensuing degradation to itself. The system shall dissipate DC, AC and RF currents from equipment and facility grounding conductors.

4.2.4.2 Site Survey

A site survey shall be conducted for all sites to determine the geological and other physical characteristics. Information to be collected shall include location of rock formations, gravel deposits, soil types etc. Perform a soil resistivity test at probe spacings of 10, 20, 30 and 40 feet (3, 6, 9 and 12m) in four directions from the proposed facility. All survey data, including soil resistivity measurements, shall be noted on a scaled drawing or sketch of the site and included in the Facility Reference Data File. Additional guidance can be found in FAA Orders 6950.19 and 6950.20.

4.2.4.3 Design

The EES shall normally consist of driven ground rods, buried interconnecting conductors and connections to underground metallic pipes (not including gas lines), and tanks. The site survey required in paragraph 4.2.4.2 shall be used as the basis for the design of the EES. The design goal for the resistance to earth of the EES shall be as low as practicable and not over 10 ohms. Where conditions are encountered such as rock near the surface, shallow soils, permafrost and soils with low moisture or mineral content, after evaluation, one of the ground enhancements listed in paragraphs 4.2.4.3.1 through 4.2.4.3.4 shall be used.

4.2.4.3.1 Chemical Enhancements.

Chemical enhancements (doping) with materials such as mineral salts, Epsom salts, sulfates, etc. should only be utilized as a last resort. Chemical enhancement is dependent on soil moisture content and requires periodic (usually yearly) re-treatment and continuous monitoring to be effective. The chemicals leach into the surrounding soil and can be deposited into the water table. Typical installation is in bored holes with ground rods and in trenches.

4.2.4.3.2 Chemical Rods.

Chemical rods also require re-treatment and monitoring to ensure continuous effectiveness. Many of these systems require a drip irrigation system in dry soil conditions. Inspections must be conducted frequently for timely detection of corrosion at connection points between conductors and the chemical rod attachment point. Normal installation is insertion into the soil in accordance with manufacturer's instructions.

4.2.4.3.3 Engineered Soil Materials

Engineered soil materials are cements, soils or clays treated with a variety of materials to enhance their conductive properties. These engineered soils can be a mixture of moisture absorbing materials such as Bentonite or homogenous clays in combination with native soils and/or chemicals. Some engineered soil enhancements utilize concrete-based materials. These materials should be avoided in areas with soil movement. The concrete can break the interconnecting conductor when combined with soil movement. Engineered soil requires the presence of moisture (> 14%) to be effective. Concrete type enhancements can be very expensive. Normal installation is installation in bored holes with ground rods and in trenches.

4.2.4.3.4 Coke Breeze

Coke breeze is a material that is produced as a by-product of coke production. Coke breeze is environmentally safe, stable, and conductive even when completely dry or frozen, non-moisture dependant, compactable and very economical to install. Normal installation is in a one-foot square trench in an EES configuration with a continuous 4/0 AWG stranded copper conductor in the center of the material (see Figure IX). Placement of the trench is based on the geometry of the facility and the physical site location. Radial trenches with a center conductor can be utilized to enhance Radio Frequency (RF) ground planes in communication facilities. The top of the coke breeze trench must be covered by a minimum of one foot of native soil. Coke breeze shall contain no more than 1% sulfur by weight. Charcoal and/or petroleum-based coke breeze shall not be substituted for coke breeze derived from coal in coke ovens. Charcoal and petroleum coke typically contain high levels of sulfur, which in the presence of moisture will accelerate corrosion of the EES.

4.2.4.3.5 Ground Dissipation Plates

In shallow soil locations with limited surface space, ground dissipation plates shall be allowed in place of ground rods in the earth electrode system. The plates shall be installed at the corners of the EES at the farthest accessible point from the facility to be protected. Plates shall be constructed of a minimum one quarter-inch thick copper and be a minimum of two feet square. These plates should be installed in a vertical plane to take advantage of seasonal moisture and temperature changes in the soil. Install the plates at the same depth or deeper than the interconnecting conductor, but maintain a minimum of one-foot of native soil above the upper edge of the plate. Attachment to the EES shall be with a 4/0 AWG bare stranded copper conductor, exothermically welded to the EES and the plate. For maximum performance, the attachment point at the plate shall be at the center of the plate, not near the edge or the corners. To further enhance the effectiveness of ground dissipation plates, they shall be configured as a Jordan Dissipation Plate Design or equal as shown in Figure X. This configuration provides 2/3 more surface area at the edge than a square plate and provides multiple sharp points for increased dissipation capability. In difficult soils/areas a combination of coke breeze trenches and ground dissipation plates is highly recommended (see Figure IX and Figure X).

4.2.4.3.6 Installation of Earth Electrode Systems in Corrosive Soils

Careful consideration must be given to the installation of any grounding system in soils with corrosive elements. Two geological areas of known concern are the volcanic soils in Hawaii and Alaska. It is recommended that supplemental cathodic protection be applied to the grounding system at these locations. A buried steel plate (acting as a sacrificial anode) is connected to the EES by a 4/0 AWG stranded bare copper conductor. The 4/0 AWG conductor shall be exothermically welded to the EES and to the sacrificial plate. The conductor shall be welded to the center of the plate, not near the edge or near the corners. Minimum sizing for the sacrificial plate is four feet square (4'x4') at ½ inch thickness. In shallow soils, this would be in addition to the standard copper ground plates. For enhanced performance, plates shall be a Jordan Dissipation Plate Design or equal (see Figure X).

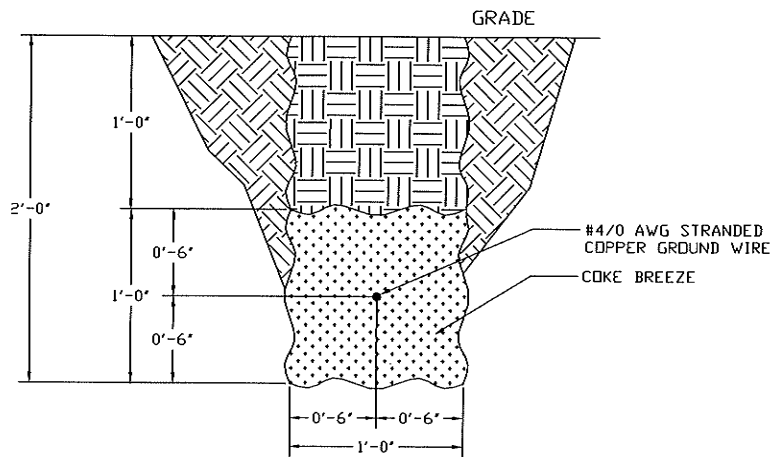

Figure IX. Grounding Trench Detail

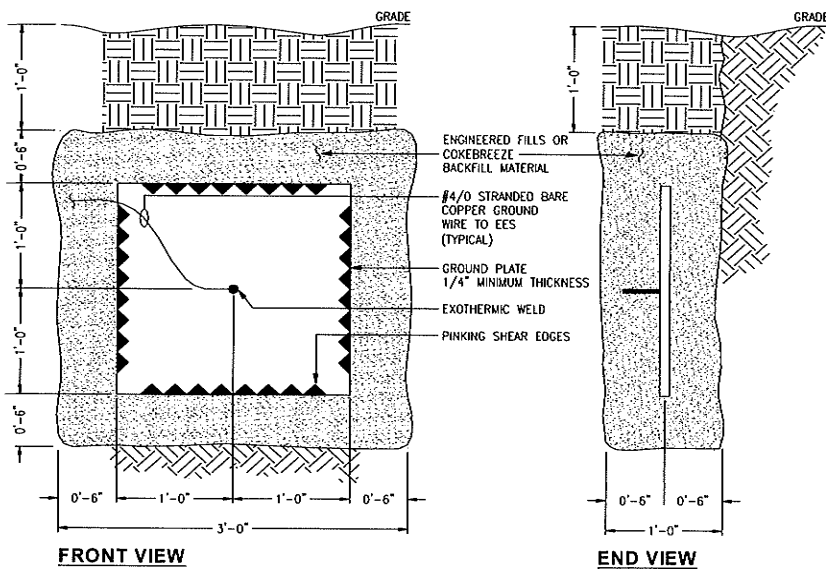
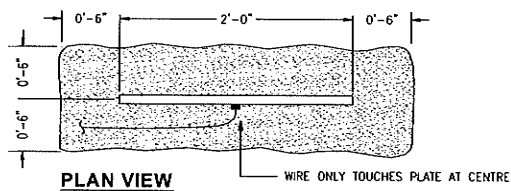

Figure X. Jordan Dissipation Plate Design

4.2.4.3.7 Configuration

The EES shall consist of at least four ground rods whose configuration and depth shall be determined by a soil test included in the site survey. At facilities that have two or more structures, e.g. a building and antenna tower, separated by 15 feet or less, a single EES surrounding both structures shall be provided. Where structures are separated by more than 15 feet but less than 30 feet, an EES shall be provided for each structure, but the EES for each structure shall be allowed to share a common side. Where the structures are separated by more than 30 feet but less than 100 feet an EES shall surround each structure and the EESs shall be interconnected by at least two buried conductors. Guidance is provided in FAA Orders 6950.19 and 6950.20.

4.2.4.3.8 Ground rods

Ground rods and their installation shall meet the following requirements:

- (a) Material and Size. Ground rods shall be copper or copper clad steel, a minimum of 10 feet in length and $\frac{3}{4}$ inch in diameter. Rod cladding shall not be less than 1/100 inch thick.
- (b) Spacing. Ground rods shall be as widely spaced as possible, and in no case spaced less than one-rod length. Nominal spacing between ground rods is between two and three times the rod length.
- (c) Depth of Rods. Tops of ground rods shall be not less than 1 foot below grade level.
- (d) Location. Ground rods shall be located 2 to 6 feet outside the foundation or exterior footing of the structure. On buildings with overhangs or sidewalks in close proximity, ground rods shall be allowed at locations further out.

4.2.4.3.9 Interconnections

Ground rods shall be interconnected by a buried, bare, 4/0 AWG copper conductor. The conductor shall be buried at least 2 feet (0.6 m) below grade level. Connections to the ground rods shall be exothermically welded. The interconnecting conductor shall close on itself forming a complete loop with the ends exothermically welded. The structural steel columns of buildings shall be connected to the EES at approximately every other column at intervals not over 60 feet with a bare, 4/0 AWG stranded copper conductor. Connections shall be by exothermic welds. All underground metallic pipes, except where prohibited by the NEC (for example gas piping), and tanks (unless cathodically protected), and the telephone ground, if present, shall be connected to the EES by a copper conductor no smaller than 2 AWG. All underground, interconnecting conductors shall be bare. Exothermic welds shall not be used where hazards exist, i.e. near fuel tanks. In these cases, connections shall be accomplished with hydraulically-crimped terminations using a minimum force of 12 tons concentrically applied. The bonding resistance of all interconnections shall be one milliohm or less for each bond when measured with a 4-terminal milliohm meter.

4.2.4.3.10 Access Well

Access wells are permissible at facilities. The well should be located at a ground rod that is in an area with access to the open soil so that checks of the EES can be made once the facility is in use. The access well shall be made from clay pipe, poured concrete, or other approved wall material and shall have a removable cover. The access well shall be constructed to provide a minimum clearance (12 inches radius) from the center of the ground rod to the inside wall of the

access well. The access well shall have an opening of a minimum 12 inch radius. Connections shall be by exothermic welds.

4.2.5 Main and Supplemental Ground Plates

A main ground plate shall be established as a common point of connection for all Signal Reference Structures (SRSs) for the entire facility. This main ground plate shall be connected to the EES with one 500 kcmil conductor. The conductor from the main ground plate to the EES shall be exothermically welded at the EES and shall be exothermically welded or connected with a UL listed pressure connector to the main ground plate. The main ground plate location shall be chosen to minimize conductor length, but shall not be more than 50 feet from the EES. Ground plates shall be copper and at least 12 inches (305 mm) long, 6 inches (152 mm) wide and 1/4 inch (6.4 mm) thick. The main ground plate shall have a clear plastic cover that bears the caption "MAIN GROUND PLATE" in black 3/8 inch (10 mm) high letters and green slashes around the caption. The main ground plate conductor shall be color-coded green at each end.

A supplemental ground plate shall be established at the opposite side of the facility to the main ground plate and shall be color coded green/orange. This supplemental ground plate shall be used only for a second connection of the signal reference plane (SRP) and multipoint ground (MPG) systems to the EES. A large facility shall be allowed to employ more than one supplemental ground plate (contact the OPR when more than one supplemental ground plate is considered). Each supplemental ground plate or plates shall be connected to the EES with a 500 kcmil conductor. The conductor from each supplemental ground plate to the EES shall be exothermically welded at the EES and shall be exothermically welded or connected with UL listed pressure connector to the plate. The length of this conductor shall be 30% longer or shorter than the conductor between the main ground plate and the EES. Ground plates shall be copper and at least 12 inches long, 6 inches wide and 1/4 inch thick. The supplemental ground plate shall have a clear plastic cover that bears the caption "SUPPLEMENTAL GROUND PLATE" in black 3/8 inch high letters and green slashes around the caption. The supplemental ground plate conductor shall be color-coded green with red tracer.

A 4/0 AWG bonding conductor shall be provided internally between the main and each supplemental ground plate and shall be color-coded green with orange tracer.

4.2.6 General Grounding and Bonding Requirements

4.2.6.1 Secure Facilities

In all areas of facilities required to maintain communications security, equipment and power systems shall be grounded in accordance with NACSIM-5203 and MIL-HDBK-232A.

4.2.6.2 Electronic Signal Return Path

The electronic signal return path shall be routed with the circuit conductor. For axial circuits, the shield serves this purpose. The electronic equipment case and SRS shall not be used as a signal return conductor.

4.2.6.3 Interior Metal Piping Systems

The interior metal piping systems shall be bonded in accordance with the NEC. An additional bond shall be required in the tower cab between the power ground system and water supply systems. Where there is a separately derived power system for the tower cab, the interior metallic piping systems near the top of the ATCT shall also be bonded to the ground plate as required in paragraph 4.2.11.2.

4.2.6.4 Electrical Supporting Structures

All metallic electrical support structures shall be electrically continuous and shall be bonded to the signal reference plane (SRP) or multipoint ground (MPG) system and to the EES.

4.2.6.4.1 Conduit

All metal conduits shall be grounded as follows:

- (a) Conduit shall have a means to be bonded, prior to entering a structure, to a ground plate or bulkhead plate located outside the structure or directly to the EES. Plate(s) shall be bonded to the EES with an insulated 4/0 AWG stranded copper conductor color-coded green with a red tracer.
- (b) All joints between conduit sections and between conduit, couplings, and boxes shall be electrically continuous. Surfaces shall be prepared in accordance with paragraph 4.1.1.7. Joints that are not otherwise electrically continuous shall be bonded with short jumpers of 6 AWG or larger copper conductor. The jumpers shall be welded in place or shall be attached with clamps, grounding bushings, or other devices approved for this purpose. All bonds shall be protected against corrosion in accordance with paragraph 4.1.1.8.3.
- (c) Cover plates of conduit fittings, pull boxes, junction boxes, and outlet boxes shall be grounded by securely tightening all available screws.
- (d) Every component of metallic conduit runs such as individual sections, couplings, line fittings, pull boxes, junction boxes and outlet boxes shall be bonded, either directly or indirectly, to the SRP or MPG system or facility steel at intervals not exceeding 50 feet.
- (e) Conduit brackets and hangers shall be securely bonded to the conduit and to the metal structure to which they are attached.

4.2.6.4.2 Cable Trays and Wireways

The individual sections of all metallic support structures (cable tray systems) and wireways shall be bonded together with a minimum 6 AWG insulated copper conductor. All bonds shall be in accordance with procedures and requirements specified in paragraph 4.1.1. All cable trays shall be bonded to the SRP or MPG system within 2 feet (0.6 m) of each end of the run and at intervals not exceeding 50 feet (15 m). The resistance of each of these connections shall not exceed 5 milliohms. The minimum size bonding conductor for connection of a cable tray and wireway to the SRP or the MPG shall be 2 AWG copper conductor.

Table VIII. Grounding Conductor Color Codes

Color	Use
Solid green	NEC required grounds
Green with red and yellow tracers	Isolated grounds
Green with yellow tracer	Single point ground
Green with orange tracer	Multipoint ground
Green with red tracer	High-Energy ground

Note: Some commercial-off-the-shelf (COTS) equipment uses green with yellow tracer as a color code for equipment grounding conductors. These conductors shall be retained and grounded as required by the NEC.

4.2.6.5 Building Structural Steel Bonding Requirements

Major structural metal members internal to and about the periphery of NAS electronic equipment rooms shall be made electrically continuous by welding each joint. This shall be accomplished for all the joints of each major structural member, including welding of each roof truss to each column location. In addition, vertical columns on the periphery of the building that are bonded to the EES (paragraph 4.2.4.3.9) shall be welded as described above. Where rebar exists, it shall be connected to the EES with a minimum 2 AWG copper conductor that is applied via an exothermic weld or a hydraulically crimped termination.

In NAS electronic equipment rooms, where steel material is used in construction (including preformed decking, wall covering, etc), it shall be directly bonded (welded) to structural steel or to reinforcing bar. Where direct bonding is not practical, indirect bonds with copper conductor conforming to Table IX shall be used with a minimum of two 2 AWG conductors per 100 square feet of steel decking, wall covering etc. These connections shall be applied via an exothermic weld or a hydraulically crimped two-hole termination. All surface coatings shall be removed in accordance with paragraph 4.1.1.7. For additional installation guidance, contact the OPR of this document.

4.2.6.6 High RF Field Bonding Requirements

FAA facilities that are located in proximity to other facilities that generate high RF levels need additional shielding to protect personnel and sensitive equipment from these external RF sources. Where a determination has been made that the signal level is sufficient to cause concern the following shall be accomplished. Metal building components and attachments such as walls, roofs, floors, door and window frames, gratings and other metallic architectural features shall be directly bonded to structural steel or to reinforcing bar if structural steel is not present, in accordance with paragraph 4.1.1. Where direct bonding is not practical, indirect bonds with copper conductor conforming to Table IX shall be used. Removable or adjustable parts and objects shall be grounded with an appropriate type bond strap as specified in paragraph 4.1.1.3. All bonds shall conform to the requirements of paragraph 4.1.1. Metal building components with a maximum dimension of 3 feet (0.9 m) or less are exempt from the requirements of this paragraph as they are not efficient receiving antennas.

4.2.7 Signal Reference Structures Requirements

All FAA enclosed building facilities, used to house NAS equipment, shall be equipped with a Signal Reference Structure (SRS). Types of SRS include the following systems:

- (a) Multipoint Ground (MPG) systems
 - 1. Conductor and plate
- (b) Signal Reference Plane (SRP)
 - 1. Signal Reference Ground Plane (SRGP)
 - 2. Signal Reference Ground Grid (SRGG)
- (c) Single Point Ground (SPG) systems
- (d) Combination of engineered hybrid system as approved by the OPR of this document.

A SRS shall be constructed in the following areas:

- a) All facility operational areas (entire room area).
- b) All other areas containing electronic equipment supporting facility operations (entire room area).
- c) Any area containing electrical equipment installed to address power quality (e.g., isolation transformers, power conditioning equipment, etc.) not in the same area as the operational or electronic equipment (on different floors, etc.) shall be bonded to the SRS system described above.

The above referenced operational, electronic and electrical equipment shall be bonded to the SRS installations in the area. In turn, all installed SRS's - on the same floor and on different floors - shall be bonded together. Individual areas of the SRS on a single floor shall be bonded to adjacent areas via at least two separate paths. The grounding system on each floor with electrical, electromechanical, or electronic equipment shall be bonded to adjacent floors via at least two separate paths.

The specific SRS type shall be selected by the OPR. SRS systems will be designed for the site-specific requirements of the facilities and equipment. SRS applications require the analysis of equipment bandwidth, and equipment and SRS impedances. SRS analysis will consider, among other parameters, operating frequencies and impedances, transmission line communication models for bonding wires, noise levels in low frequency analog-based equipment, and the influence of high frequency digital signal and logic equipment. SRGGs and SRGPs will be considered when recommended by a vendor. MPGs, SRGGs, and SRGPs can be constructed on ceilings, walls, or floors.

Multiple components of the facility SRS – except any SPGs – shall be bonded together with a minimum of two 4/0 AWG conductors.

All signal-carrying conductors, axial lines, and waveguides and cabling and interconnections between equipments shall be routed in immediate proximity to the SRGG or SRGP when utilized.

A typical ground system is shown in Figure XI.

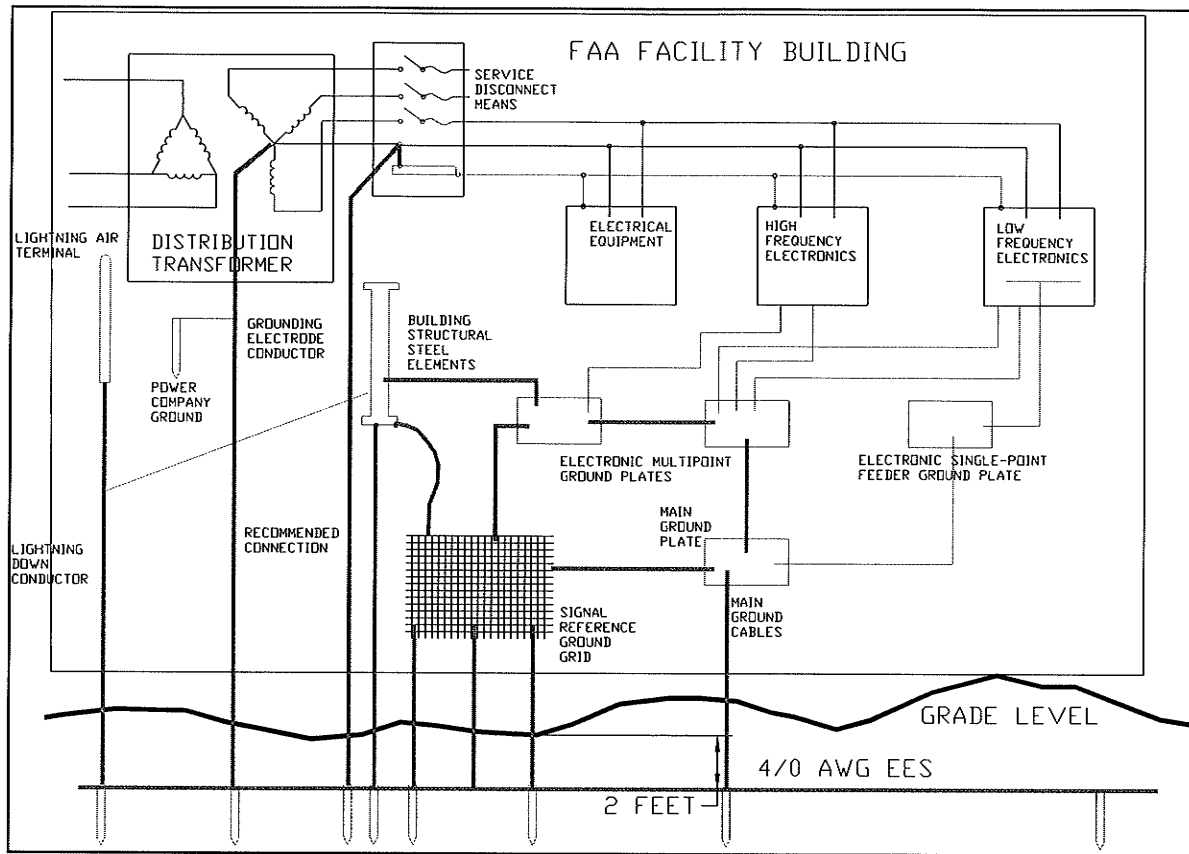

Figure XI. Facility Grounding System

Note figure colors are to distinguish systems and do not form part of a required color code

4.2.7.1 Multipoint Ground Systems

The protection of electronic equipment against potential differences and static charge buildup shall be provided by interconnecting all non-current-carrying metal objects to a multipoint ground system that is effectively connected to the EES. The multipoint ground system consists of installed network of plates and bonding jumpers, racks, frames, cabinets, conduits, wireways, cable trays enclosing electronic conductors, structural steel members, and conductors used for interconnections. The multipoint ground system shall provide multiple low impedance paths to the EES as well as between various parts of the facility, and the electronic equipment within the facility so that any point of the system has a low impedance path to the EES. This will minimize the effects of spurious currents present in the ground system due to equipment operation or malfunction, or from lightning discharges. The multipoint ground system shall not be used in lieu of the safety ground required by the NEC. The multipoint ground system is not to be used as a signal return path.

Exception: For buildings of 200 ft² or less, only the main ground plate is required which shall be connected to the EES with two 4/0 AWG stranded copper conductors. One of the conductors shall be 30% longer than the other. All signal grounding (single point or multipoint) shall terminate on this plate. No additional plates are required.

4.2.7.1.1 Multipoint Ground Plates and Buses

The location of the ground plate shall be chosen to facilitate the interconnection of all equipment cabinets, racks and cases within a particular area. If more than one ground plate is necessary, they shall be installed at various locations within the facility. Ground buses shall be used when distributed grounding is desired with a long row of equipment cabinets. Ground plates shall be copper and at least 12 inches long, 6 inches wide and ¼ inch thick. Ground buses shall be copper. Ground bus width and thickness shall be selected from Table IX, and shall be as long as required. Ground plates and buses shall be identified with a permanently attached plastic or metal label that is green with distinguishing bright orange slashes. The label shall bear the caption “ELECTRONIC MULTIPOINT GROUND SYSTEM” in black 3/8-inch (10 mm) high letters.

4.2.7.1.2 Ground Conductors – Plate to Plate and Plate to Bus

Conductors between plates and buses in the multipoint system shall be insulated and sized in accordance with Table IX based on the maximum path length to the farthest point in the multipoint ground system from the EES. To determine the distance to the farthest point in the multipoint system, add the length of all conductors in the multipoint system to reach the farthest plate in the system via the longest path as shown in Figure XII. Divide the sum obtained by two to obtain the maximum path length. Utilize this path length to determine the conductor size from Table IX, but in no case use a conductor smaller than 4/0 AWG. These conductors shall be color-coded green with an orange tracer or shall be clearly marked for four inches at each end and wherever exposed with a green tape overlaid with an orange tracer. Additionally, when routed in cable trays, conductors shall be color-coded every three feet. Where conductors are routed through cable trays, they shall be insulated and separated from the other conductors as far as possible. These conductors shall be insulated.

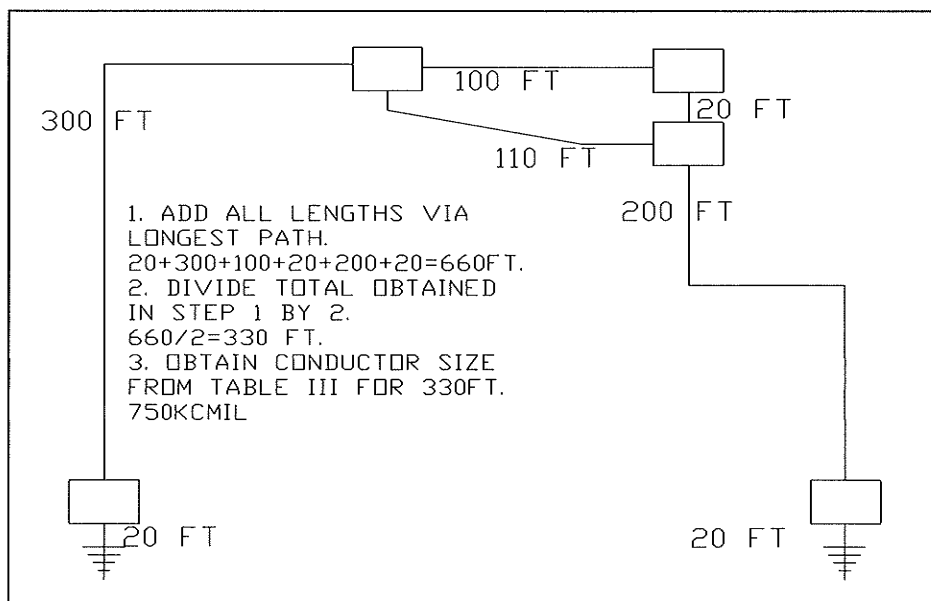

Figure XII. Multipoint Ground Conductor Size Determination

4.2.7.1.3 Ground Conductors (Plate and Bus to Equipment)

Conductors from plates and buses in the multipoint system to equipment chassis shall be sized in accordance with Table IX based on the maximum path length from the plate or bus to the equipment. These insulated conductors shall be color-coded green with an orange tracer or shall be clearly marked for 4 inches at each end and wherever exposed with a green tape overlaid with an orange tracer. Where routed through wireways, the color-coding shall be visible by opening any cover. Provide color-coding 4 inches long at intervals not exceeding 3 feet where ground conductors are routed through cable trays.

Table IX. Size of Electronic Multipoint Ground Interconnecting Conductors

Conductor Size	Max. Path Length		Bus Bar Size		Max. Path Length	
	Ft.	(m)	Inch	(mm)	Ft.	(m)
750 kcmil*	375	(114.3)	4 x 1/4	(100 x 6.4)	636	(193.9)
600 kcmil*	300	(91.4)	4 x 1/8	(100 x 3.2)	318	(96.9)
500 kcmil	250	(76.2)	3 x 1/4	(75 x 6.4)	476	(145.1)
350 kcmil	175	(53.3)	3 x 1/8	(75 x 3.2)	238	(72.5)
300 kcmil	150	(45.7)	2 x 1/4	(50 x 6.4)	318	(96.9)
250 kcmil	125	(38.1)	2 x 1/8	(50 x 3.2)	159	(48.5)
4/0 AWG	105	(32.0)	2 x 1/16	(50 x 1.6)	79	(24.1)
3/0 AWG	84	(25.6)	1 x 1/4	(25 x 6.4)	159	(48.5)
2/0 AWG	66	(20.1)	1 x 1/8	(25 x 3.2)	79	(24.1)
1/0 AWG	53	(16.2)	1 x 1/16	(25 x 1.6)	39	(11.9)
1 AWG	41	(12.5)				
2 AWG	33	(10.1)				
4 AWG	21	(6.4)				
6 AWG	13	(4.0)				

* Where these conductors are not available, parallel conductors shall be allowed, such as three 250 kcmil conductors in place of one 750 kcmil conductor, or two 300 kcmil conductors in place of one 600 kcmil conductor. The conductor sizing is based on providing a cross-sectional area of 2000 circular mils per linear foot. The bus bar sizes are chosen from available cross sections and exceed the cross-sectional requirement of 2000 circular mils per linear foot.

4.2.7.1.4 Protection

Provide mechanical protection for all conductors in the electronic multipoint ground system where they are subject to physical damage. This protection shall be provided by conduit, floor trenches, routing behind permanent structural members, or other means as applicable. Where routed through metal conduit, the conduit shall be bonded to the conductor at each end.

4.2.7.1.5 Conductor Labeling

At each multipoint grounding conductor termination the conductor shall be labeled to identify the point of termination of the other end of the conductor. This shall be accomplished by

embossed label. These conductors shall also be identified every 50 feet and in junction boxes in the manner above indicating both ends.

4.2.7.2 Signal Reference Planes

Signal reference planes (SRPs) shall be constructed of either an SRGG, SRGP, or a combination of both, in accordance with the narrative below:

- (a) **Signal Reference Ground Grid (SRGG):** A SRGG shall consist of a grid of two inch wide copper strips, 26 gauge or thicker, laid on a two feet by two feet grid, welded at each grid intersection. The SRGG shall be installed below a raised floor, at or above a dropped ceiling, or both. The perimeter of the SRGG shall extend to within six inches of the room perimeter or the edge of the raised floor (and/or dropped ceiling) area if the raised floor (and/or dropped ceiling) does not fill the entire room. The SRGG and raised floor shall be bonded together at least every six feet with bare conductors. Dropped ceiling metalwork shall be bonded to ceiling mounted SRGG using guidance provided by the OPR. A 4/0 AWG or larger bare copper conductor shall be routed around the SRGG within six inches of the grid perimeter. The copper strips of the SRGG shall be bonded to the perimeter 4/0 AWG bare copper conductor at every intersection with 4 AWG bare copper conductors. The 4/0 AWG perimeter conductor shall be bonded to the EES with a minimum of four 4/0 AWG conductors spaced as widely apart as practicable.

Building structural steel within the perimeter of the grid and within 6 feet of the grid shall be bonded to the SRGG with a 4/0 AWG or larger conductor. All conduits, wireways, pipes, cable trays, or other metallic elements that penetrate the area shall be bonded to the SRGG where they enter the area and every 25 feet for their entire length within the area. All conduits, wireways, pipes, cable trays, or other metallic elements within 6 feet of the grid shall be bonded to the SRGG. These bonds shall be made with 4 AWG copper conductors minimum.

- (b) **Signal Reference Ground Plane (SRGP):** All SRGP designs shall be approved by the OPR of this document. A SRGP shall consist of copper sheets, 24 gauge thickness minimum. The sheets shall be welded by any method approved by the OPR including butt, pan or lap methods. The SRGP shall be bonded to the EES with a minimum of four 4/0 AWG conductors spaced as widely as practicable.

Building structural steel within the perimeter of the ground plane and within 6 feet of the ground plane shall be bonded to the SRGP with a 4/0 AWG or larger conductor. All conduits, wireways, pipes, cable trays, or other metallic elements that penetrate the area shall be bonded to the SRGP where they enter the area and every 25 feet for their entire length within the area. All conduits, wireways, pipes, cable trays, or other metallic elements within 6 feet of the ground plane shall be bonded to the SRGP. These bonds shall be made with 4 AWG copper conductors minimum.

All conductors and cabling shall lay on or very close (nominally, less than $\lambda/20$ of the highest system frequency) to the SRGG or SRGP. Installation of a SRGG or a SRGP shall be permitted below a raised floor, at or above a dropped ceiling, or both. Floor and ceiling portions of a

SRGG or a SRGP shall be bonded together with a minimum of four 4/0 AWG conductors spaced as widely spaced as practicable. All bonding connections between the equipment and the SRGG or SRGP shall be close-coupled, i.e., the bonding jumpers shall be as short as possible, and routed to the closest SRGG or SRGP location. When either an SRGG or an SRGP is utilized under equipment, a raised floor construction is preferred to enable routing of all connecting conductors and cabling close to the SRGG or SRGP. In this case conductors and cabling shall enter at the base of the equipment

4.2.7.3 Connection of MPG and SRP Systems to the Main and Supplemental Ground Plates

The MPG and SRP systems shall be connected to the Main and Supplemental ground plates with conductors sized in accordance with paragraph 4.2.7.1.2. Each connection shall be to the nearest MPG plate or SRP.

4.2.7.4 Connection of Electronic Enclosures to the SRS

Bonding connections to the SRS shall be allowed either to the below floor SRP or directly to the raised floor system or alternatively to an MPG as constructed in paragraph 4.2.7.1. The length of the bonding conductor shall be less than 19 inches. To prevent the possibility of problems due to resonance of a single bonding strap, two widely spaced straps of unequal length (one of the conductors shall be 30% longer or shorter than the other) shall be used to bond the equipment to the SRS. Bonding straps shall be at least 1" wide and at least 26 gauge. Bonding straps shall be in accordance with paragraph 4.1.1.3 and installed in accordance with paragraph 4.1.1.2. When necessary, any radius in the bonding connectors shall be 8 inches minimum.

4.2.8 Electronic Single Point Ground System Requirements

4.2.8.1 General

Electronic single point ground systems shall be installed in FAA facilities where required by equipment or requested by the vendor and approved by the OPR of this document. FAA facilities that do not utilize single point ground equipment are not required to install a single point ground system. The electronic single point ground system shall be isolated from the power grounding system, the lightning protection system and SRP or MPG systems (except at the main ground plate). The electronic single point ground system shall be terminated at the main ground plate or to the EES, whichever is the closest. The electronic single point ground system shall be configured to minimize conductor lengths. Conductive loops shall be avoided by maintaining a trunk and branch arrangement as shown in Figure XIII.

4.2.8.2 Ground Plates

Main, branch and feeder ground plates shall be of copper and at least 12 inches long, 6 inches wide, and ¼ inch thick. The plates shall be mounted on non-conductive material of sufficient cross section to rigidly support the plates after all conductors are connected. Bolts or other devices used to secure the plates in place shall be insulated or shall be of a non-conducting material. The plates shall be mounted in a manner that provides ready accessibility for future inspection and maintenance.

4.2.8.3 Isolation between Single Point and SRP or MPG Systems

The minimum resistance between the electronic single point ground and the SRP or MPG systems shall be 10 megohms. The resistance shall be measured after the complete network is installed and before connection to the EES or to the SRP or MPG system at the main ground plate.

4.2.8.3.1 Resistance

The maximum resistance of any bond to a ground plate shall not be greater than 1 milliohm.

4.2.8.4 Ground Conductors

All ground conductors shall be insulated copper conductors color-coded green with a yellow tracer.

4.2.8.4.1 Main Ground Conductor

When a single point ground system is established directly from the EES, the single point main ground conductor shall be an insulated 500 kcmil copper conductor not exceeding 50 feet in length. The main ground conductor shall be connected to the EES by an exothermic weld in accordance with paragraph 4.1.1.2.1.

4.2.8.4.2 Trunk and Branch Ground Conductors

An insulated trunk ground conductor shall be installed in each facility from the main ground plate to each of the branch plates as shown in Figure XIII. Insulated copper branch ground conductors shall be installed between feeder plates and branch ground plates. These conductors shall be routed to provide the shortest practical path. Trunk conductors shall be 4/0 AWG insulated copper conductors with a yellow tracer for systems where the farthest feeder plate in the system is no more than 400 feet from the EES via the conductor runs. For longer runs, select a conductor size based on providing a cross sectional area of 500 circular mils (cmil) per running foot of conductor length but in no case smaller than 250 kcmil. Trunk ground conductors shall be exothermically welded or connected with UL listed double bolted connectors to the ground plates in accordance with paragraph 4.1.1.2.4 and shall be mounted as shown on the facility drawings.

4.2.8.4.3 Electronic Equipment Ground Conductors

The conductor from the feeder ground plate (branch ground plate if there is no need for a feeder ground plate in the conductor run) to the isolated terminal or bus on the electronic equipment shall be sized at 500 cmil per running foot with a minimum size of 6 AWG.

4.2.8.5 Interconnections

All connections to the single point ground system shall be made on ground plates or buses. Split bolts and other connections to existing conductors are not allowed.

4.2.8.6 Labeling

The single point ground system shall be clearly labeled to preserve its integrity as described in the following sections.

4.2.8.6.1 Conductor Identification

At each single point grounding conductor termination the conductor shall be labeled to identify the point of termination of the other end of the conductor. This shall be accomplished by embossed label. These conductors shall also be identified every 50 feet and in junction boxes in the manner above indicating both ends.

4.2.8.6.2 Ground Plate Labeling

All ground plates shall be protected with a clear plastic protective cover spaced $\frac{3}{4}$ inch (19 mm) from the plate and extending 1 inch (25.4 mm) beyond each edge. This cover shall have a green label with distinguishing bright yellow slashes attached bearing the caption: "CAUTION, ELECTRONIC SINGLE POINT GROUND" in black $\frac{3}{8}$ inch high (10 mm) letters.

4.2.8.6.3 Protection

Provide mechanical protection for all conductors in the electronic single point ground system where they are subject to damage. This protection shall be provided by conduit, floor trenches, routing behind permanent structural members, or other means as applicable. Single point ground conductors shall be isolated from contact with any metal elements.

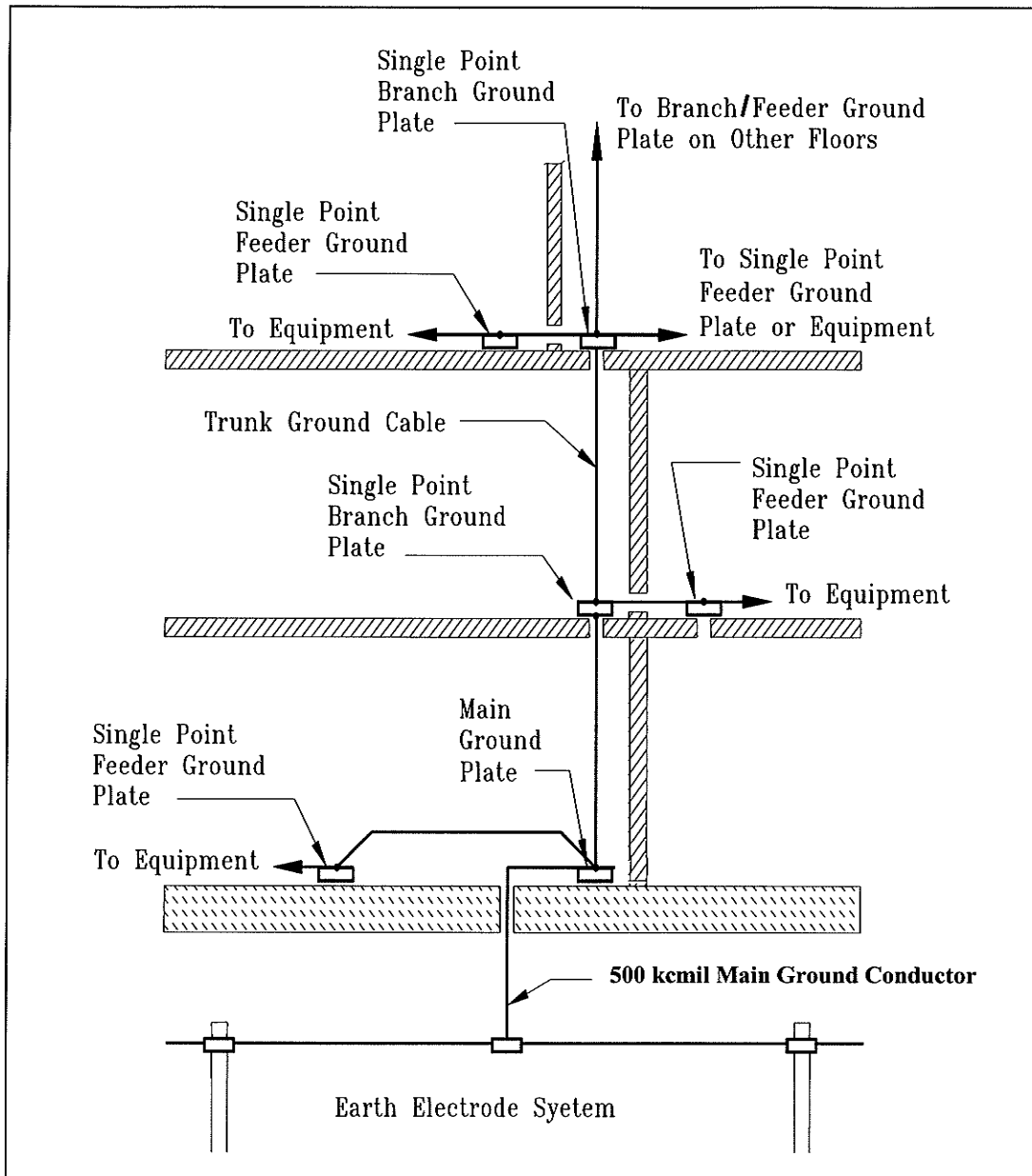

Figure XIII. Electronic Single Point Ground System Installation

4.2.9 DC Bus Grounding Requirements

Contact the OPR for specific DC Bus grounding designs.

4.2.10 National Electrical Code (NEC) Grounding Compliance

4.2.10.1 General

The facility electrical grounding shall exceed requirements of NEC Article 250 as specified herein.

4.2.10.2 Grounding Electrode Conductors

Grounding electrode conductors shall conform to the following:

- (a) Facilities shall have the grounded conductor (neutral) connected to the EES by a copper grounding electrode conductor at the service disconnecting means. The grounding electrode conductor shall be sized in accordance with the NEC, but never smaller than 2 AWG.
- (b) The grounding electrode conductor connection shall be made to the neutral bus in the service disconnecting means.
- (c) If the grounding electrode conductor is spliced using a hydraulically crimped connector, the connector will comply with paragraph 4.1.1.2.4.4. When a grounding electrode conductor is routed through a metal enclosure, e.g., conduit, the enclosure shall be bonded at each end to the grounding electrode conductor.
- (d) An equipment grounding conductor shall be routed with associated phase conductors to a second building or structure. The grounded conductor routed from the first building or structure shall not be connected to the equipment grounding conductor or EES at the second building or structure.
- (e) For a separately derived system, the system bonding jumper and the grounding electrode conductor shall be located at the first downstream system disconnecting means or overcurrent device. For the grounding electrode conductor the connection shall be to the nearest effectively grounded structural metal member. Where it is not feasible to connect the grounding electrode conductor to a structural metal member, the EES shall be used. The grounding electrode conductor shall be copper and sized in accordance with NEC requirements, except that it shall not be smaller than 2 AWG.

Separately derived systems, other than at the top of a tall ATCT, serving NAS critical and essential services shall have an additional grounding electrode conductor terminated to the EES.

4.2.10.3 Equipment Grounding Conductors

The equipment grounding conductor shall be a green-insulated wire routed in the same raceway as its' related phase and neutral conductors. Cord-connected equipment requiring an equipment ground shall include the equipment grounding conductor as an integral part of the power cord. Where power is supplied to electronic equipment through a cable and connector, the connector shall contain a pin to continue the equipment grounding conductor to the equipment chassis. Conduit or cable shields shall not be used as the equipment grounding conductor. All installations shall be in accordance with the NEC, FAA-C-1217 and with the following:

- (a) Parity-sized equipment grounding conductors, same sized as the associated phase conductors, shall be used when it is recommended as good practice in a manufacturer's equipment installation requirements. Where a parity-sized equipment grounding conductor is installed it shall be bonded to bonding bushings at each end of the raceway with a bonding jumper the same size as the equipment grounding conductor. This shall be accomplished for branch circuits as a minimum.
- (b) Grounding terminals in all receptacles on multioutlet assemblies shall be hardwired to an equipment grounding conductor. Strips that depend upon serrated or toothed fingers for

grounding shall not be used.

- (c) All flexible metal conduits shall be provided with an external bonding jumper in addition to the internal equipment grounding conductor. The bonding jumper shall be a 6 AWG green-insulated stranded copper conductor. The bonding jumper shall terminate on fittings listed for grounding at each end of the flexible metal conduit.
- (d) A separate equipment grounding conductor shall be provided for each overcurrent device and as required by the NEC.

4.2.10.4 Color Coding of Conductors

4.2.10.4.1 Grounded Conductors

- (a) Grounded conductors shall be insulated and color-coded white for 120/208V and 120/240V and gray for voltages above 120/240V. Conductors larger than 6 AWG shall be allowed to be re-identified as the grounded conductor except that green conductors shall not be re-identified.
- (b) In any raceway, box, cable tray, or enclosure, where grounded conductors of different systems are present, each grounded conductor shall be identified by system, in accordance with the NEC.
- (c) Color-coding of grounded conductors shall be applied at each connection and at every point where the conductor is accessible. Where routed through raceways with covers, the color coding shall be visible by removing or opening any cover. Where conductors are routed through cable trays, color coding 3 inches (75 mm) in length shall be provided at intervals not exceeding 3 feet (0.9 m).

4.2.10.4.2 Equipment Grounding Conductors

- (a) Equipment grounding conductors shall be solid green in color. Insulated conductors larger than 6 AWG shall be allowed to be re-identified with green tape. White or gray conductors shall not be re-identified as equipment grounding conductors. The equipment grounding conductor from the grounding terminal of an isolated receptacle shall be color-coded green with yellow and red tracers.
- (b) Color-coding of equipment grounding conductors shall be applied at each connection and at every point where the conductor is accessible. Where routed through raceways with covers, the coding shall be visible by removing or opening any cover. Where conductors are routed through cable trays, color coding 3 inches (75 mm) long shall be provided at intervals not exceeding 3 feet (0.9 m).
- (c) Some COTS equipment is supplied with a green and yellow equipment grounding conductor. These conductors do not need to be replaced. These conductors shall not be connected to the single point ground system.

4.2.10.4.3 Control and DC Power Cables and Conductors

Color-coding for conductors in control cables shall be in accordance with NEMA Standard WC-5. DC power conductors, including battery cables, shall be color-coded as follows: a red for positive conductor and black for a negative conductor. The red conductor shall be marked with a positive (+) symbol and the black conductor shall be marked with a (-) symbol. The symbols shall be applied to the conductor with a shrink embossed label.

4.2.10.5 Non-Current-Carrying Metal Equipment Enclosures

- (a) All non-current-carrying metal enclosures such as raceways, cable trays and panel boards shall be electrically continuous. Insulating finishes shall be removed between grounding/bonding areas of mating surfaces or bonding jumpers. Ferrous conduit (galvanized rigid metal conduit only) shall be equipped with bonding bushings at each end and the equipment grounding conductor shall be bonded to the bushings with a bonding jumper the same size as the equipment grounding conductor. This shall be accomplished in accordance with Figure XIV.
- (b) Ferrous materials shall be used for enclosures, raceways, and cable trays to provide shielding from magnetic fields
- (c) All battery supporting racks shall be bonded either directly to the EES or to any grounded structure with a 2 AWG conductor.

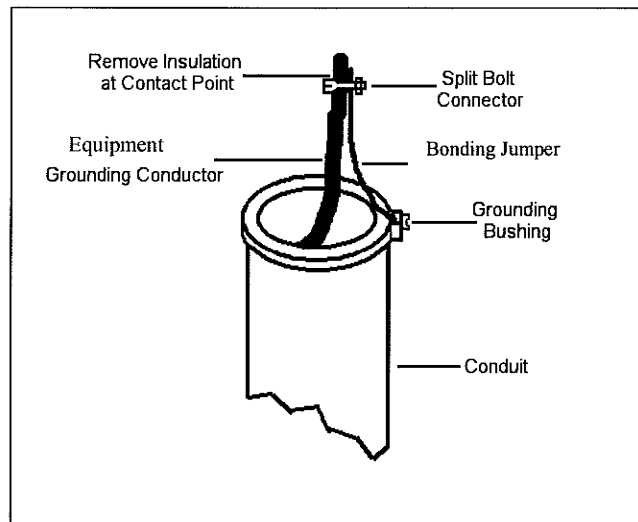

Figure XIV. Bonding of Conduit and Grounding Conductor

4.2.11 Airport Traffic Control Towers (ATCT) Special Requirements

ATCT's (Figure XV) having electronic areas in the cab, junction and sub-junction levels at the top of the shaft and also in the associated base building present a unique set of challenges for implementing lightning and transient protection. The numerous conductors running between electronic equipment located in the base building and beneath the tower cab are subject to large electromagnetic fields during a lightning strike. For this reason, special techniques shall be applied to provide an environment that minimizes the damaging effects of lightning. These techniques are mandatory for ATCT facilities with base buildings that meet the following:

- (a) Over 100 feet in height to the highest point of the building, and
- (b) Located in areas with a lightning flash density of $0.5/\text{km}^2/\text{year}$ ($1.3/\text{mile}^2/\text{year}$) or greater.

These techniques are recommended for application to all ATCT facilities.

4.2.11.1 General

The lightning protection, electrical, electromechanical, electronic systems, and building steel of structures shall be bonded together for safety. It is not possible for equipment near the top of the tower and at the base to have the same electrical potential during a lightning strike. It is therefore necessary to reference all systems at the top of the tower to each other and treat this area as a separate facility. SPD's shall be provided at the base building/tower shaft facility entrance and at the top of the shaft.

4.2.11.2 Main Ground Connections

In order to assure good high frequency grounding during normal operation a low impedance connection must be provided to the EES. A main ground plate shall be established on the lowest level with electrical, electromechanical, or electronic equipment serving the ATCT cab (see Figure XV). All grounding systems present at or above this level within the ATCT shall be connected to this main ground plate. A 1-foot wide 26 gauge or thicker copper strap shall connect this main ground plate to a plate at the base of the ATCT. This strap shall be routed continuously from the main ground plate to the base plate without sharp bends, loops, kinks, or splices and will provide two square feet of surface per linear foot of conductor. Substitution of a combination of conductors providing the same surface area per linear foot shall be allowed. This strap or conductors shall be mechanically bonded to the main ground plate and the base plate. The strap shall be sandwiched between the plate at each end and a 1"x1"x1/8" copper bar to insure good electrical contact and mechanical strength. Connect the base plate to the EES in an access well with two exothermically welded 500 kcmil conductors. The OPR should be consulted for assistance in meeting this requirement.

4.2.11.3 Power Distribution

All power distribution for the areas at the top of the ATCT shall be via separately derived systems. These separately derived systems shall be grounded in accordance with the requirements of NEC article 250 and paragraph 4.2.10.2(e) at the first downstream disconnecting means or overcurrent device. This point of connection is mandated to facilitate the effective installation of an SPD. An SPD, in accordance with paragraph 4.2.2.2 shall be installed on the load side of the first downstream disconnecting means or overcurrent device of each separately derived system. The ground bus at the first disconnecting means or overcurrent device shall be bonded to the main ground plate established in accordance with the requirements paragraph 4.2.11.2. This connection is in addition to the grounding electrode conductor requirements of NEC article 250.

The interior metallic piping systems at the top of the ATCT shall be bonded to the main ground plate established in accordance with the requirements paragraph 4.2.11.2. This connection is in addition to the bonding requirements of NEC article 250.

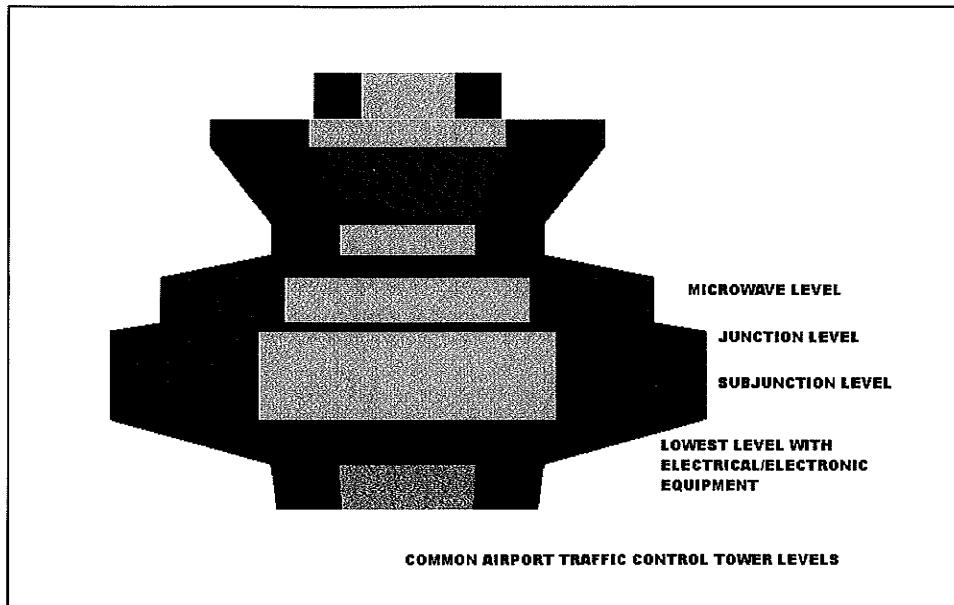

Figure XV. Airport Traffic Control Tower Levels

4.2.11.4 Bonding

Metal elements comprising the ATCT shall be bonded together and to the EES.

Provision shall be made to ensure that all rebar used in tower construction is electrically bonded together – continuous laterally and vertically to the EES – for the entire ATCT. Rebar shall be bonded to the EES with a minimum 2 AWG copper conductor that is applied via an exothermic weld or a hydraulically crimped termination.

At the top of the ATCT, the tower cab and all equipment locations supporting the cab shall be enveloped in a rudimentary Faraday cage. This shall be accomplished by bonding together all structural and fabrication steel. In turn, this steel cage shall be electrically bonded to the rebar in the concrete construction. Penetrations of the Faraday cage, e.g., conduit, water pipe, etc., shall be bonded to the cage at the point of entry. Bonding jumpers shall be a minimum 2 AWG copper conductor.

At all levels of an ATCT, horizontal metal transitions (floors, stairs, walkways, etc.) shall be bonded to structural steel and/or rebar. Elevator support structures shall be bonded to horizontal metal transitions and to the EES. All bonding jumpers shall be a minimum 2 AWG copper conductor.

If this last requirement cannot be met, contact the OPR of this document.

4.2.11.5 Signal, Communications, Axial Cables and Control Line Protection

Transient protection shall be applied at each end of vertical cables routed between the equipment room near the top of the ATCT and the associated base building. Cables between the tower cab

and equipment room areas shall be protected in accordance with paragraphs 4.2.2.5 through 4.2.2.7. Both facility and equipment levels of protection shall be provided for these lines. Enclosing metallic cabling in ferrous conduit or the use of all dielectric fiber optic cable can significantly reduce the threat of lightning related damage to ATCT and base building circuits.

4.2.11.6 Signal Reference Structure

An SRS shall be constructed in accordance with paragraph 4.2.7. This shall be accomplished for the cab and all other areas at the top of the ATCT that contain electrical, electromechanical or electronic equipment serving the cab.

4.2.11.7 Floor Coverings for Electronic Equipment and Operational Areas

Floor coverings for the cab and areas serving the cab shall be either tile or carpeting and shall be of static dissipative material. These shall be installed per manufacturers' specifications and connected to a component of the SRS – except to any single point ground system. The floor covering and installation shall meet the requirements of paragraph 4.1.3.4.8.

4.2.11.8 Single Point Grounding

Single point ground systems, if required, shall be constructed in accordance with paragraph 4.2.8. All single point ground systems and independent ground systems mandated by equipment manufacturers shall be bonded to the ATCT main ground plate established in accordance with the requirements paragraph 4.2.11.2.

4.3 Equipment Requirements

Electronic equipment installed in FAA NAS facilities must comply with the requirements contained in this section.

4.3.1 Electronic Signal Lines and Cables

Electronic signal lines shall be shielded twisted pairs with an insulated covering. Cables consisting of multiple twisted pairs shall have the individual shields isolated from each other. Cables shall have an overall shield with an overall insulated covering.

4.3.1.1 Termination of Individual Shields

Termination of individual shields shall be in accordance with paragraph 4.1.2.3.2.

4.3.1.2 Termination of Overall Shields

Termination of overall shields shall be in accordance with paragraph 4.1.2.3.3.

4.3.2 Signal Control and Data Line Entrance

Procurement organizations are responsible for ensuring that electronic equipment, such as radars, nav aids, or transmitters, supplied for use in FAA operational facilities, shall be provided with transient protection that reduce surges and transients to below the equipment transient susceptibility level. Signal control and data line entrance protection shall be provided as an integral part of all electronic equipment mounted internally or on the exterior of the equipment and at the facility entrance. The equipment susceptibility level is defined as the transient level

on the signal, control or data lines that cause damage, degradation, or upset to electronic circuitry connected to the line. Protection for these lines is in addition to the facility protection levels specified in paragraphs 4.2.2.5 through 4.2.2.7. The procurement organizations are responsible for ensuring that testing is performed to determine voltage, current, or energy levels that will cause immediate damage to components, shorten operating life, or cause operational upset to the equipment. These tests shall consider all electrical and electronic equipment components exposed to the effects of surges or transients. The procurement organization shall ensure that facility and equipment entrance protection is coordinated to limit transients at the equipment to below the equipment susceptibility level. Requirements of this paragraph shall be included in the comprehensive control and test plans outlined in paragraph 4.1.4.2. In all cases, the following characteristics shall be evaluated.

- (a) Component damage threshold. The damage threshold is the transient level that renders the component nonfunctional or operationally deficient. For solid-state components, voltage is usually the relevant parameter.
- (b) Component degradation level. The component degradation level is the transient voltage or energy level that shortens the useful life of the component.
- (c) Operational upset level. The operational upset level is the transient voltage or energy level that causes an unacceptable change in operating characteristics for longer than 10 milliseconds for analog equipment or a change of logic state for digital equipment.

4.3.2.1 Lines and Cables Requiring Protection

Surge protective devices shall be placed on both ends of signal, data, and control lines longer than 10 feet connecting pieces of equipment not located on and bonded to the same SRS, or when the SRGG, SRGP, and the multipoint ground system is located in different rooms or on different floors. (refer to Figure XVI). This includes all signal, data, and control lines. This equipment shall be protected as specified in paragraph 4.3.2.

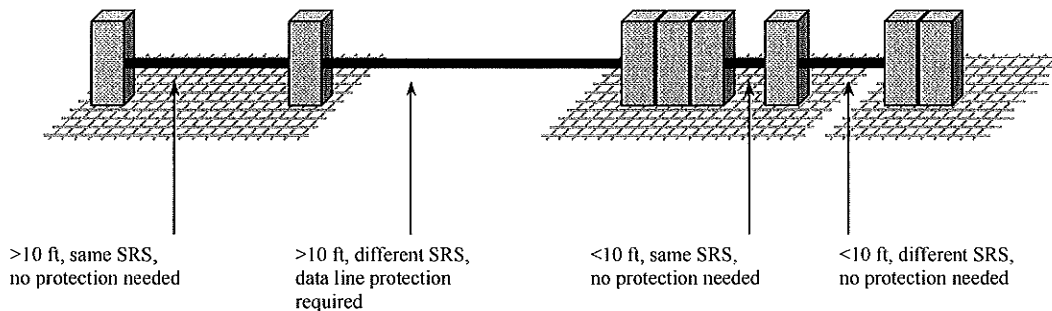

Figure XVI. Lines and Cables Requiring Protection

4.3.3 Power Entrance

Surge protective devices, components or circuits for protection of electronic equipment power lines shall be provided by the equipment manufacturer as an integral part of all electronic equipment mounted internally or on the exterior of the equipment at the cable entrance (see paragraph 4.2.2.1). These devices shall be positioned at the AC power conductor entrance to electronic equipment housed in a shielded, compartmentalized enclosure. SPDs at equipment shall provide a clamping level less than the equipment operational upset susceptibility level as

defined in paragraph 4.3.2(c) and must conform to the relevant columns of Table X, Table XI, and Table XII.

- (a) Maximum continuous operating voltage (MCOV). The maximum continuous operating voltage is the maximum RMS voltage an SPD will withstand at its maximum operating temperature continuously without degradation or change to any of its parameters greater than +/-10%. The MCOV will be at least 10% above the nominal system voltage. Leakage current as defined below shall not be exceeded.
- (b) Leakage current. The DC leakage current will be less than 1mA for voltages at or below $1.414 \times \text{MCOV VDC}$.
- (c) Clamp (discharge) voltage. Clamp (discharge) voltage is the maximum voltage that appears across an SPD output terminal while conducting surge currents. Clamp (discharge) voltage measured at 3kA (to ensure performance in the linear region without impacting the device lifetime performance) 8/20 microseconds shall not change more than 10% over the operating life of the Surge Protection Device as defined in Table XII. Electronic Equipment Power Entrance SPD Requirements.
- (d) Overshoot voltage. Overshoot voltage shall not exceed 2 times the SPD clamp voltage for more than 10 nanoseconds. Overshoot voltage is the surge voltage level that appears across the SPD terminals before the device turns on and clamps the surge to the specified voltage level.
- (e) Self-restoring capability. The SPD shall automatically return to an off state after surge dissipation when line voltage returns to normal.
- (f) Operating lifetime. The SPD shall safely dissipate the number and amplitude of surges listed in Table XII.
- (g) Fusing. Any fusing shall not increase the clamp voltage of the SPD and shall pass the surge current levels listed in Table XII up to the 20kA level without opening. Any fusing provided shall be coordinated with the supply fusing.

4.3.3.1 Slope Resistance

It is the purpose of this parameter to create a regime where it is possible to ensure device coordination. The slope resistance for the equipment protection shall meet the requirements of Table X and is calculated via the formula below:

$$R_{\text{slope}} = (V_{10} - V_1) / 9000$$

Where V_{10} = the clamping voltage measured at 10kA 8/20 μ s

and

Where V_1 = the clamping voltage measured at 1kA 8/20 μ s

The values of V_{10} and V_1 used shall be measured values determined in actual testing of the SPDs and not calculated.

Table X. Equipment Power Entrance Slope Resistance Requirements

Location	Slope Resistance
Electronic equipment power entrance	60 mΩ Minimum

The voltages that must be achieved during testing at 3kA with an 8/20μs current impulse is shown in Table VI. All voltages shall be measured at the device terminals. The 8/20μs current impulse wave shape shall not lead or lag the voltage wave shape by more than 30 degrees.

Table XI. Protection Voltages at 3kA for the Equipment Power Entrance

Location	System Voltage	V ₃	Limit
Electronic equipment power entrance	120/208 120/240	550 L-N, L-G 850 L-L	Minimum
Electronic equipment power entrance	277/480	850 L-N, L-G 1350 L-L	Minimum
Electronic equipment power entrance	380Delta	1350 L-L, L-G	Minimum
Electronic equipment power entrance	480 Delta	1350 L-L, L-G	Minimum

Table XII. Electronic Equipment Power Entrance SPD Requirements

Surge Current Amplitude 8/20μs Waveform	Surge Number lifetime Electronic equipment power entrance
1kA	100
10kA	25
20kA	1

Each level of surge current and the number required represents a single lifetime of an SPD.

4.3.3.2 DC Power Supply Transient Suppression

Procurement organizations are responsible for ensuring that power supplies that use 60 Hertz (Hz) power and furnish DC operating voltages to solid-state equipment used in direct support of the NAS, shall have transient suppression components from each output of the power supply to the equipment chassis. The chassis side of suppressors shall be connected as directly as possible to rectifier output ground. Operating characteristics of suppression components provided for power supply rectifier output lines shall be as follows:

- (a) Operating lifetime. The transient suppressors shall safely dissipate 1000 surges with an amplitude of 200 Amps and a waveform of 1.2/50 μ s. Methods of testing shall be in accordance with the guidance in IEEE C62.45.
- (b) Limiting Voltage. The voltage shall be limited to a point 20% below the maximum Peak Inverse Voltage (PIV) of the DC rectifier.

4.3.3.3 Externally Mounted Electronic Equipment

When electronic equipment is not enclosed in a facility (e.g. RVR, LLWAS, OM, etc.) the power SPD protection specified in this document rated for facility entrance shall be provided. For the signal and control cables of this equipment both facility and electronic equipment entrance shall be provided at the equipment entrance as a combined protector. The grounding conductor shall be bonded to the equipment chassis and shall be of minimum length and routed to avoid sharp bends, kinks or loops. Access shall be provided for visual inspection and replacement of these SPDs.

4.3.4 Electronic Equipment Grounding

4.3.4.1 Electronic Cabinets, Racks, and Cases

All electronic cabinets, racks, and cases shall provide a grounding terminal or bus whereby a grounding jumper or wire can be mechanically connected through an electrically conductive surface to the basic frame. The metal enclosure of each individual unit or piece of electronic equipment shall be bonded to its cabinet, rack, or directly to the SRP or MPG system.

4.3.4.2 Isolated Grounding Receptacles

For reduction of electrical noise, isolated receptacles installed in accordance with the NEC shall be permitted. The isolated equipment grounding conductors used for these receptacles shall be color-coded green with red and yellow tracers at each termination, and when passing through an enclosure without termination.

4.3.4.3 Portable Equipment (with grounding conductor)

Portable electrical or electronic equipment cases, enclosures, and housings shall be considered to be adequately grounded for fault protection through the equipment grounding conductor of the power cord, provided continuity is firmly established between the case, enclosure or housing, and the receptacle ground terminal. The power cord equipment grounding conductor shall not be used for signal grounding.

4.3.4.4 AC Power Filters

All filter cases shall be directly bonded in accordance with paragraph 4.1.1.10 to the equipment case or enclosure. Filter leakage current shall not exceed 5 milliamperes (mA) per filter. Transient suppression devices, components or circuits shall be installed in accordance with paragraph 4.2.2.1.

4.3.5 Equipment Signal Grounding Requirements

4.3.5.1 Input and Output Electronic Signals

Where a common signal reference is used, low frequency analog input and output signals shall be balanced with respect to the signal reference. Extreme care shall be taken to maintain isolation between the single point ground system and the SRP or MPG system, except at the main ground plate or EES.

4.3.5.2 Multipoint Grounding of Electronic Equipment

When permitted by circuit design requirements, all internal ground references shall be directly bonded to the chassis and the equipment case. Where mounted in a rack, cabinet or enclosure, the electronic equipment case shall be bonded to the racks, cabinet or enclosure in accordance with paragraph 4.3.4.1. The DC resistance between any two points within a chassis or electronic equipment cabinet serving as ground shall be less than 25 milliohms total and not more than 2.5 milliohms per joint. Shields shall be provided as required for personnel protection and electromagnetic interference reduction.

4.3.5.2.1 Prevention of Resonance in Bonding Straps

To prevent the possibility of problems due to resonance of a single bonding strap, two widely spaced straps of unequal length shall be used to connect the equipment to the multipoint grounding bus in the equipment cabinet. Bonding shall be in accordance with the recommended practices as expressed in paragraph 4.2.7.4 and IEEE Std 1100-1999 paragraph 8.5.4.6.

4.3.5.3 Single Point Grounding of Electronic Equipment

When electronic equipment performance necessitates an isolated electronic single point ground system for proper operation, all the equipment and its installation shall comply with the following:

The single point ground system or plane shall be isolated from the electronic equipment case. If a metal chassis is used as the electronic single point ground, the chassis shall be floated relative to the case. Design practices shall be such that the single point ground of the electronic equipment can be properly interfaced with other electronic equipment without compromising the system. If necessary, this single point ground system shall be filtered for high frequencies.

4.3.5.3.1 Single Point Input and Output Signal Requirements

The “high” and “low” sides of input and output signals shall be isolated from the electronic equipment case and balanced with respect to the signal reference. Operating and adjusting controls, readouts or indicating devices, protective devices, monitoring jacks and signal connectors shall be designed to isolate both the high and low side of the signal from the case.

4.3.5.3.2 Single Point Case Isolation Requirements

The isolation between the single point ground system terminals and the case shall be 10 megohms or greater with all external power, signal and control lines disconnected from the electronic equipment.

4.3.5.3.3 Single Point Power Isolation Requirements

The isolation between the single point ground system terminals and each power conductor (including AC neutral) shall be 10 megohms or greater with the power switch in the on position and the power disconnected from the supply.

4.3.5.4 Equipment Single Point Ground Terminals

Insulated single point ground system terminal(s) shall be provided on each electronic equipment case where an isolated signal reference is required. The single point ground reference for the internal circuits shall be connected to this terminal. This terminal(s) shall be used to terminate cable shields as appropriate, and to connect the isolated signal ground of the electronic equipment to the single point ground system in the facility. A connector pin, a screw or pin on a terminal strip, an insulated stud, jack or feed through, or an insulated wire shall be an acceptable terminal so long as each terminal is clearly marked, labeled, or coded in a manner that does not interfere with its intended function. These marks, codes, or labels shall be permanently affixed and shall utilize green with yellow stripes. Wire insulation shall be green with a yellow tracer.

4.3.5.4.1 Connection of Electronic Equipment to the Single Point Ground System

Each equipment single point ground terminal shall be connected to the facility single point ground system in accordance with the following:

- (a) Individual units or pieces of electronic equipment which by nature of their location or function cannot or should not be mounted with other electronic equipment, shall have an insulated copper conductor installed between the electronic single point ground terminal specified in paragraph 4.3.5.4 and the nearest electronic single point ground system ground plate. This conductor shall have a cross-sectional area of 500 circular mils per linear foot with a minimum size of 6 AWG.
- (b) Where two or more units or pieces of electronic equipment are mounted together in a rack or cabinet, a single point ground bus bar shall be installed as shown in Figure XVII. The bus bar shall be copper and shall provide a minimum cross-sectional area of 125,000 circular mils (e.g., a 1 inch by 1/8 inch bus bar). The bus bar shall be drilled and tapped for #10 screws. The holes shall be located as required by the relative location of the isolated electronic single point grounding terminals on the electronic equipment. The bus bar shall be mounted on insulating supports that provide at least 10 megohms resistance between the bus bar and the rack or cabinet.
- (c) Each electronic equipment isolated single point ground terminal shall be interconnected to the bus bar by means of a solid or flexible tinned (6 AWG minimum) copper jumper of sufficient cross sectional area so that its resistance is 5 milliohms or less. The jumper shall be insulated or mounted in a manner that maintains the required degree of isolation between the reference conductor and the enclosure. The interconnecting jumper shall be attached to the bus bar at a point nearest to the single point ground terminal to which the strap is attached. An insulated copper conductor shall be installed from the bus bar in the cabinet to the nearest electronic single point ground system. This conductor shall provide at least 500 circular mils per linear foot, and must be a minimum 6 AWG conductor.

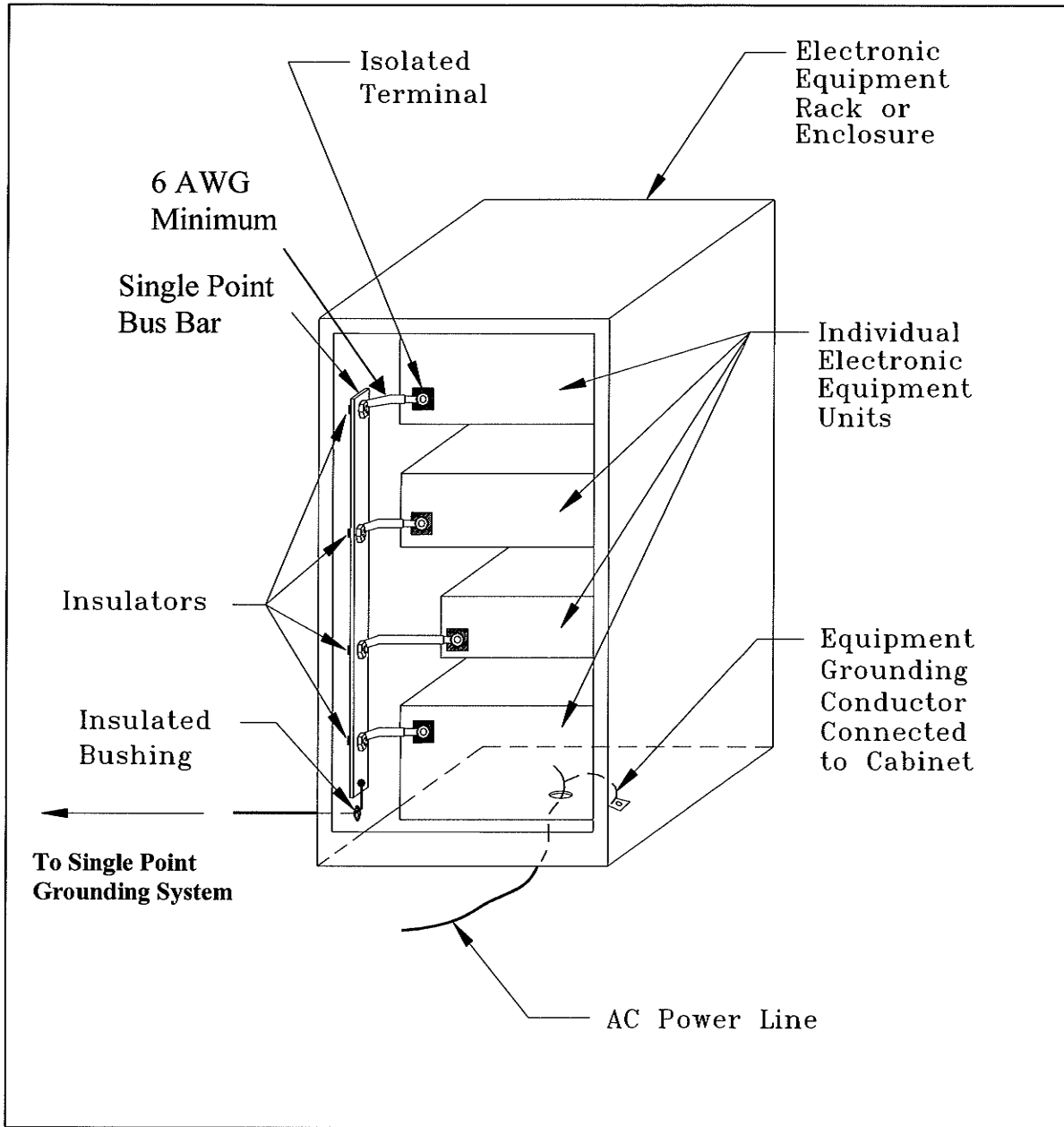

Figure XVII. Single Point Electronic Ground Bus Bar Installation in Rack or Cabinet

4.3.6 Equipment Shielding Requirements

4.3.6.1 Control of Apertures

Unnecessary apertures shall be avoided. Only those shield openings needed to achieve proper functioning and operation of the equipment shall be provided. Controls, switches, and fuse holders shall be mounted so close metal-to-metal contact is maintained between the cover housing of the devices and the case. Metal control shafts shall be grounded in accordance with paragraph 4.3.6.2. Where nonconductive control shafts are necessary, a close fitting metal sleeve peripherally bonded to the case shall be provided for the shaft. The length of the sleeve shall be no less than four times its diameter. Lights shall be filtered or shielded as needed to maintain the required degree of shielding effectiveness. Ventilation and drainage holes shall utilize appropriate shielding techniques. Care shall be taken to assure that the shielding is well bonded to the shield completely around the opening.

4.3.6.2 Metal Control Shafts

Metal control shafts shall be grounded to the equipment case through a low impedance path provided by close-fitting conductive gaskets, metal finger stock, or grounding nuts.

4.3.6.3 Shielded Compartments

Shields shall be bonded to the chassis for fault protection in accordance with paragraph 4.1.1.

4.3.7 Circuit and Equipment ESD Design Requirements

4.3.7.1 Circuit Design and Layout

The design, layout, and packaging of assemblies, circuits, and components integrated into electrical and electronic equipment shall incorporate methods and techniques to reduce susceptibility to ESD.

4.3.7.2 Component Protection

External protection shall be provided for all integrated circuits, discrete components, and other parts without internal ESD protection that are inherently susceptible to ESD. Protective components shall be installed as close as possible to the ESD susceptible item.

4.3.7.3 ESD Withstand Requirements

In the installed and operational configuration, all equipment cabinets, enclosures, racks, controls, meters, displays, test points, interfaces, etc., shall withstand a static discharge of 15,000 Volts per ESD Association Standard Test Method ESD-STM 5.1, Electrostatic Discharge Sensitivity Testing – Human Body Model (HBM). Equipment that is tested shall not suffer any operational upset or damage to any component or assembly to successfully pass ESD withstand requirements.

This Page Intentionally Left Blank

5 DETAILED REQUIREMENTS

Section is not applicable to this standard.

This Page Intentionally Left Blank

6 NOTES

6.1 Acronyms and Abbreviations

The following are acronyms and abbreviations used in this standard

A	Amperes	L-L	Line to Line
AC	Alternating current	L-N	Line to Neutral
ANSI	American National Standards Institute	LRU	Line replacement unit
AWG	American Wire Gauge	m	Meter
Cm	Centimeter(s)	mA	Milliamperes
Cmil	Circular mils	MCM	See kcmil
DC	Direct current	MCOV	Maximum continuous operating voltage
e.g.	For example	MHz	Megahertz
EES	Earth electrode system	MPG	Electronic multipoint ground system
EMI	Electromagnetic interference	mm	Millimeter(s)
EPP	Equipotential plane	NAS	National Airspace System
EOS	Electrical overstress	NEC	National Electrical Code
ESD	Electrostatic discharge	NEMA	National Electrical Manufacturers Association
Et.al.	And others	NFPA	National Fire Protection Association
FAA	Federal Aviation Administration	No.	Number
ft.	Foot (feet)	OPR	Office of Primary Responsibility
GP	Groundable point	PVC	Polyvinyl chloride
Hz	Hertz	RF	Radio frequency
i.e.	That is	RGS	Rigid galvanized steel
in.	Inch(es)	RFI	Radio frequency interference
IEEE	Institute of Electrical and Electronics Engineers	RMM	Remote maintenance monitoring
kA	Kiloampere	SAS	Silicon avalanche diode suppressors
kcmil	Thousand circular mils	SDM	Service disconnecting means
kg	Kilogram	SPD	Surge protective device
kHz	Kilohertz	SPG	Electronic single point ground system
LAN	Local area network	SRG	Signal reference grid
LPGBS	Lightning Protection, Grounding, Bonding and Sheilding	UL	Underwriters Laboratories
“	Inch(es)	μs	Microseconds
#	Number	‘	Foot (feet)
L-G	Line to Ground	V	Volts

6.2 Guidelines

Engineering design guidelines are provided for lightning protection, grounding, bonding, shielding, and transient protection in FAA Orders 6950.19 and 6950.20. Guidance for EMI protection is in MIL-HDBK-253, and for electrostatic discharge (ESD) in NFPA 77, DOD-HDBK-263, DOD-STD-1686 and IEEE1100.

6.3 Version Cross-Reference

Due to the major reorganization of FAA-STD-019e it is not feasible to provide an exact cross-reference between this standard and the previous version, FAA-STD-019d. However the handbook to FAA-STD-019e will provide information on requirements revisions and detail cost effective methods of applying them. Where possible references to the original requirements in FAA-STD-019d will be provided.

**MINIMUM WAGES FOR FEDERAL AND FEDERALLY
ASSISTED CONSTRUCTION CONTRACTS**

This project is funded, in part, with Federal-aid funds and, as such, is subject to the provisions of the Davis-Bacon Act of March 3, 1931, as amended (46 Sta. 1494, as amended, 40 U.S.C. 276a) and of other Federal statutes referred to in a 29 CFR Part 1, Appendix A, as well as such additional statutes as may from time to time be enacted containing provisions for the payment of wages determined to be prevailing by the Secretary of Labor in accordance with the Davis-Bacon Act and pursuant to the provisions of 29 CFR Part 1. The prevailing rates and fringe benefits shown in the General Wage Determination Decisions issued by the U.S. Department of Labor shall, in accordance with the provisions of the foregoing statutes, constitute the minimum wages payable on Federal and federally assisted construction projects to laborers and mechanics of the specified classes engaged on contract work of the character and in the localities described therein.

General Wage Determination Decisions, modifications and supersedes decisions thereto are to be used in accordance with the provisions of 29 CFR Parts 1 and 5. Accordingly, the applicable decision, together with any modifications issued, must be made a part of every contract for performance of the described work within the geographic area indicated as required by an applicable DBRA Federal prevailing wage law and 29 CFR Part 5. The wage rates and fringe benefits contained in the General Wage Determination Decision shall be the minimum paid by contractors and subcontractors to laborers and mechanics.

NOTICE

The most current **General Wage Determination Decisions** (wage rates) are available on the IDOT web site. They are located on the Letting and Bidding page at <http://www.dot.state.il.us/desenv/delett.html>.

In addition, ten (10) days prior to the letting, the applicable Federal wage rates will be e-mailed to subscribers. It is recommended that all contractors subscribe to the Federal Wage Rates List or the Contractor's Packet through IDOT's subscription service.

PLEASE NOTE: if you have already subscribed to the Contractor's Packet you will automatically receive the Federal Wage Rates.

The instructions for subscribing are at <http://www.dot.state.il.us/desenv/subsc.html>.

If you have any questions concerning the wage rates, please contact IDOT's Chief Contract Official at 217-782-7806.