

NOTES:

- THE CONTRACTOR SHALL ESTABLISH TOP OF FOUNDATION ELEVATION PER PLAN AND PROFILE DRAWINGS. FOR EACH LIR TOWER TO BE INSTALLED, THE CONTRACTOR SHALL FIELD-VERIFY THE ACTUAL FOUNDATION TOP ELEVATION PRIOR TO CUTTING LIR TUBE. THE REQUIRED TUBE CUT LENGTH SHALL BE DETERMINE AS FOLLOWS:
 FOR MALS STEADY-BURNING LIGHT BARS
 $TUBE\ CUT\ LENGTH = LAMP\ \phi\ ELEVATION - FDN\ TOP\ ELEVATION\ (FIELD-VERIFIED) - 1.2\ FT.$
 FOR RAIL FLASHERS:
 $TUBE\ CUT\ LENGTH = LAMP\ \phi\ ELEVATION - FDN\ TOP\ ELEVATION\ (FIELD-VERIFIED) - 1.5\ FT.$
- CUT TUBE LENGTH FROM THE 20 FOOT TUBE "A" STOCK AS REQUIRED, USING A TABLE SAW WITH A DIAMOND OR CARBIDE ABRASIVE BLADE. ALL SAW CUTS SHALL BE PERPENDICULAR TO THE TUBE'S LONGITUDINAL AXIS. DEBURR CUT EDGES.
- USE SAND PAPER TO ROUGHEN THE SURFACES TO BE BONDED TO THE STAND PLATE PER DETAIL "3". CLEAN THE ROUGHENED SURFACES WITH A SOLVENT (TRICHLOROETHYLENE, ACETONE, OR METHYL ETHYL KETONE).
- CONTRACTOR SHALL BOND EACH JOINT BY SPREADING A LIGHT COAT OF MIXED ADHESIVE ON BOTH SURFACES TO BE BONDED. SLOWLY SLIDE THE TUBE ONTO THE STAND PLATE, WHILE ROTATING IT TO EXCLUDE AIR. THE BONDING ADHESIVE MATERIALS, 2-PART EPOXY, FUSOR 304-1 RESIN AND 304-2 HARDENER, FUSOR 304-1 AND 304-2 ARE AVAILABLE FROM LORD CORP CHEMICAL PRODUCTS GROUP, ERIE PA. THE ADHESIVE MUST BE MIXED AND CURED IN AIR TEMPERATURES WHICH DO NOT DROP BELOW 67°F. CURING IS COMPLETE AFTER 48 HOURS. FOLLOW MANUFACTURER'S INSTRUCTIONS.
- ASSEMBLE LIR STRUCTURES IN HORIZONTAL POSITION PER DETAIL "2". WHEN LOWERING TOWER, SECURE MOUNTING STAND ON ANCHOR BOLTS, REMOVE TWO 5/8" BOLTS AT REAR OF MOUNTING STAND ASSEMBLY, AND PIVOT INNER SECTION UP TO VERTICAL POSITION. PLACE STAND PLATE (BOTTOM OF MAST) OVER FOUR 5/8" STUDS IN MOUNTING STAND, AND FASTEN WITH HEX NUTS. NOTE POSITION OF TAPPED HOLES IN STAND PLATE. HOLES MUST BE POSITIONED TO ACCOMMODATE INSTALLATION OF TUBE CAP AND TEE BAR ASSEMBLY PER DETAIL "4".
- SEE INSTRUCTION BOOK TI6850.77 FOR ADDITIONAL ASSEMBLY INSTRUCTIONS.
- CONTRACTOR SHALL PROVIDE FAA WITH TWO SPARE "A" TUBES. PROVIDE TO FAA ANY TUBE SECTION GREATER THAN 10' LONG.
- TEE BAR SHALL BE ALIGNED PEPENDICULAR TO RUNWAY CENTERLINE +/- 1°.
- A SMALL HOLE MUST BE CUT IN THE RUBBER LINER OF TUBE CAP TO ALLOW ACCESS FOR TEE BAR WIRING INSTALLATION. DO NOT REMOVE RUBBER LINER.
- SAWCUT FOUR 2" LONG SLOTS, EQUALLY SPACED AROUND PERIMETER, IN TOP OF LIR TUBE TO ALLOW EASY INSERTION OF TUBE CAP.
- LIR SWIVEL IS REQUIRED ONLY FOR STATIONS WHICH PIVOT AT AN ANGLE TO RUNWAY CENTERLINE. SPLICE SECTION ALLOWS CROSSBAR ASSEMBLY (WHEN CLAMPS ARE LOOSENED) TO BE ROTATED 90° TO ALLOW COMPLETE LOWERING OF TOWER.
- THE CONTRACTOR SHALL COVER THE 2" CENTER HOLE OF THE MG-20 MOUNTING STAND PLATE ASSEMBLY WITH A 2"-DIA PLASTIC OR ALUMINUM MINI-LOUVER. MCMaster-CARR CAT. NO. 2016K23, 2016K13, AND 2016K3 MINI-LOUVERS MEET THIS REQUIREMENT. SEAL UNUSED HOLE IN THE MOUNTING STAND PLATE WITH A 1/2" THREADED PLASTIC PLUG.

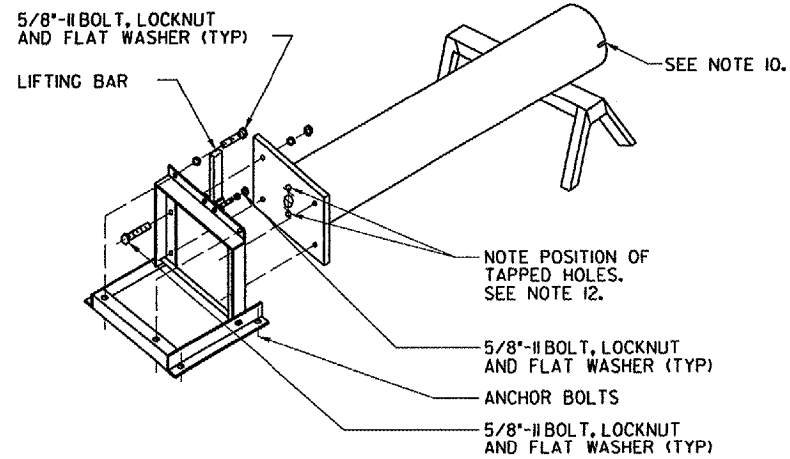

TILTED CONDITION

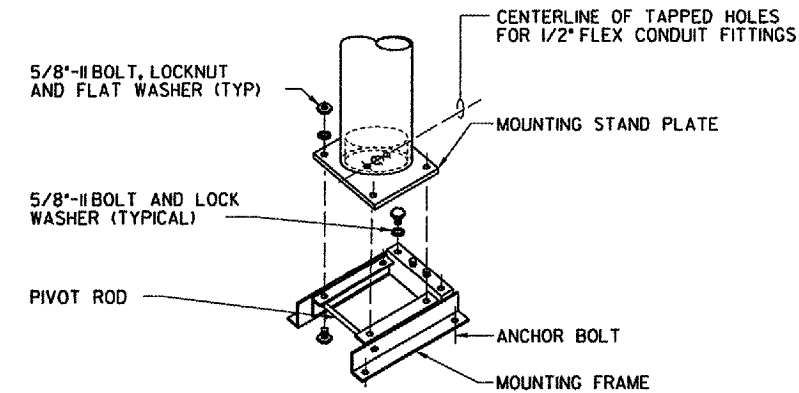

MOUNTING STAND ASSEMBLY DETAILS

2 DETAIL NOT TO SCALE

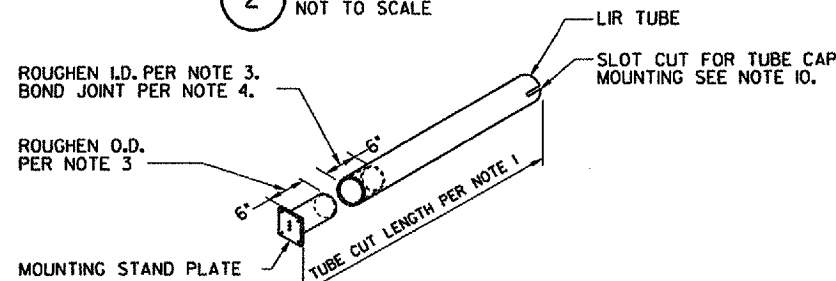

LIR MAST BONDING DETAILS

3 DETAIL NOT TO SCALE

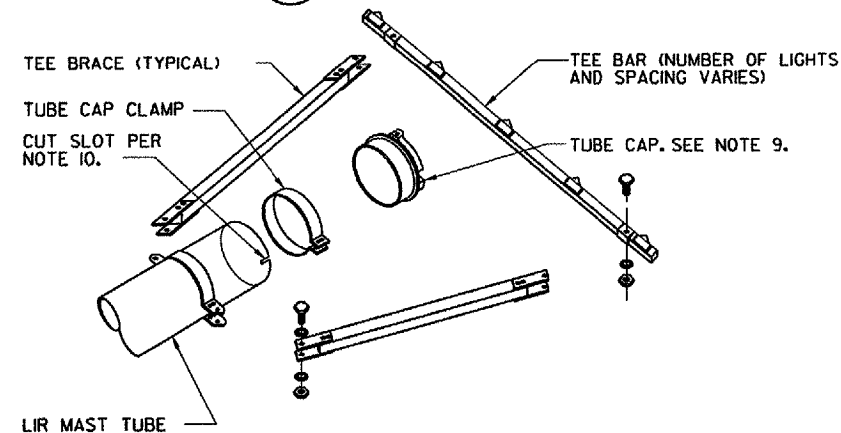

TEE BRACE ASSEMBLY DETAILS

4 DETAIL NOT TO SCALE

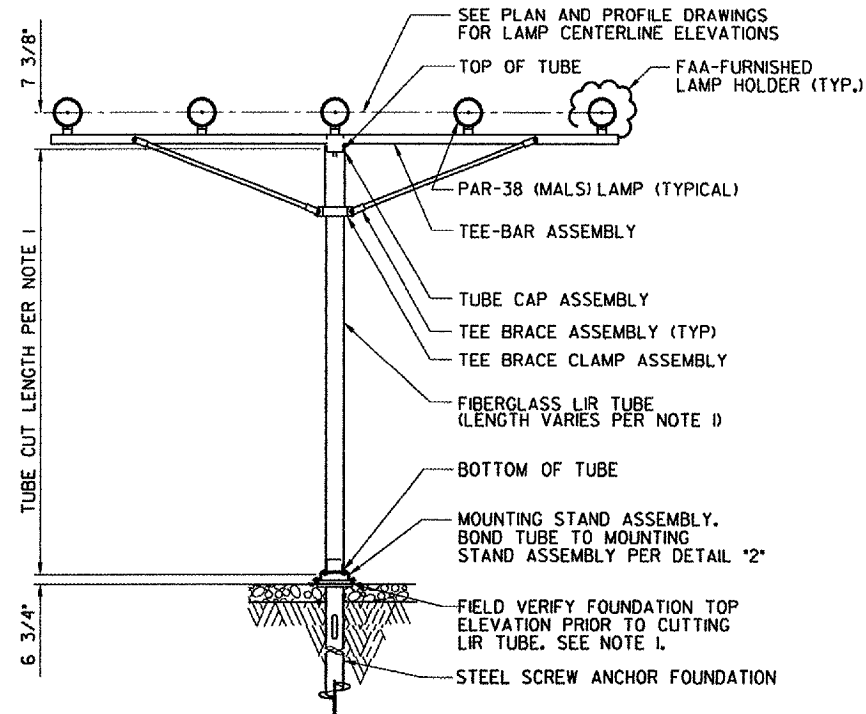

ELEVATION MALS LIGHT BAR ON MG-20 LIR STRUCTURE

1 DETAIL NOT TO SCALE

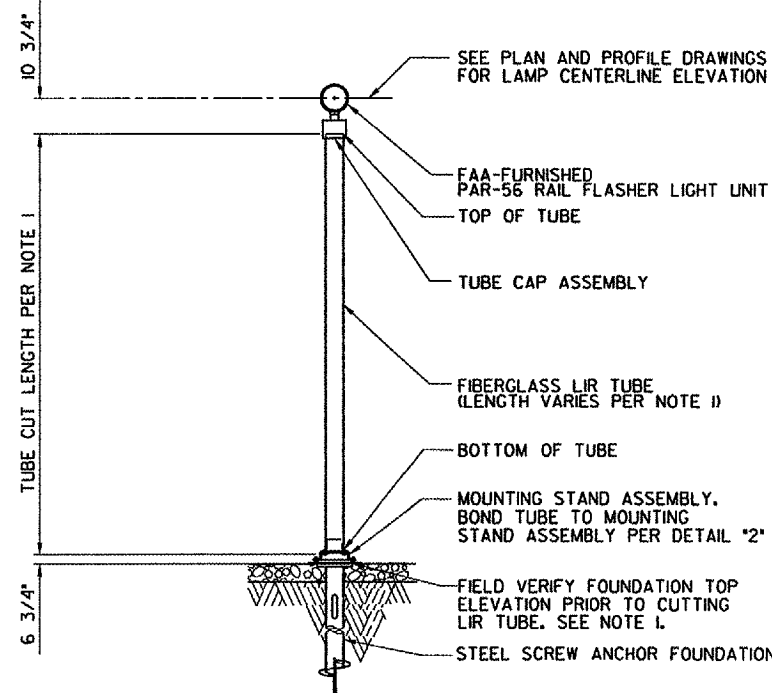

ELEVATION MALS RAIL FLASHER ON MG-20 LIR STRUCTURE

5 DETAIL NOT TO SCALE

CONTRACTOR SHALL SUBMIT REQUESTS FOR SUBSTITUTION OF SPECIFIC MANUFACTURER'S ITEMS SHOWN PER PARAGRAPH 10 OF THE SPECIAL SPECIFICATIONS.

DEPARTMENT OF TRANSPORTATION
FEDERAL AVIATION ADMINISTRATION
GREAT LAKES REGION CHICAGO, ILLINOIS

MALS R
STRUCTURE ASSEMBLY DETAILS
FOR LIR TOWER, TYPE MG-20
RUNWAY 33

AURORA		AURORA MUNICIPAL AIRPORT		IL
REVIEWED BY	SUBMITTED BY	APPROVED BY		
	PROJ ENGR, TIMOTHY DYER	PLATFORM MGR, CLELAND MICHEEL		
DESIGNED	TAD	ISSUED BY	DATE	JCN
DRAWN	TAD	CHICAGO NAS IMPLEMENTATION CENTER	02/18/2006	
CHECKED	EGS		DRAWING NO	REV
			ARR-D-MALS R33-S01	

REV	DATE	DESCRIPTION	JCN	REDLINE DATE	APVD